

# COMPUTER GRAPHICS AND ART

AUGUST, 1976

Vol. 1, No. 3



August, 1976

GRACE C. HERTLEIN, Editor

Calif. State Univ., Chico, California  
 JUDITH P. CALLAHAN, Editorial Assistant  
 BARBARA WOLMER, Production Assistant  
 BERKELEY ENTERPRISES, INC., Publisher

Contributing Editors

ALFRED BORK, Univ. of Calif., Irvine  
 CHARLES CSURI, Ohio State Univ.,  
 Columbus, Ohio

HERBERT W. FRANKE, Munich, Germany  
 ARTHUR W. LUEHRMANN, Dartmouth College  
 Hanover, New Hampshire

ABRAHAM MOLES, Univ. of Strasbourg,  
 France

NICHOLAS NEGROPONTE, Mass. Inst. of  
 Technology, Cambridge, Mass.

JACKIE POTTS, Social Security Adm.,  
 Baltimore, Md.

ERIC TEICHOLZ, Harvard University,  
 Cambridge, Mass.

Advisory Board Members

EDMUND C. BERKELEY, Editor and Publisher,  
 Newtonville, Mass.

KENNETH KNOWLTON, Bell Laboratories,  
 Murray Hill, New Jersey

FRANK MALINA, Editor, "Leonardo",  
 Paris, France

FRIEDER NAKE, Univ. of Bremen,  
 Bremen, Germany

JOSEPH RABEN, Editor, "Computers & the  
 Humanities", Queens College, Flushing,  
 New York

RICHARD SPEER, Evergreen State College,  
 Olympia, Washington

MATERIALS SUBMITTED FOR PUBLICATION SHOULD  
 BE IN ENGLISH (WITH AN ABSTRACT), TYPED  
 DOUBLE SPACED ON STANDARD LETTER-SIZED  
 PAPER, WITH TWO COPIES OF THE MANUSCRIPT  
 SENT TO:

EDITOR, COMPUTER GRAPHICS AND ART  
 Berkeley Enterprises, Inc. -  
 Chico Branch  
 555 Vallombrosa, #35  
 Chico, California 95926  
 (Phone) 916-343-2712

NOTE: ILLUSTRATIONS ARE HIGHLY DESIRABLE  
 WITH WRITTEN TEXTS.

SUBSCRIPTION RATES, BILLING OFFICES, AD-  
 VERTISING RATES & OTHER BUSINESS QUES-  
 TIONS SHOULD BE SENT TO:

Judith P. Callahan - Business Office  
 COMPUTER GRAPHICS AND ART  
 Berkeley Enterprises, Inc.  
 815 Washington Street  
 Newtonville, Mass. 02160

COPYRIGHT 1976 by Berkeley Enterprises, Inc.,  
 Newtonville, Mass. 02160

COMPUTER GRAPHICS AND ART is published  
 quarterly, 4 issues per year. Printed  
 in the U.S.A.

ANNUAL SUBSCRIPTION RATES

Personal, U.S. & Canada, \$10 per year  
 Personal, Foreign, \$13 per year  
 Library, Departmental, \$15 per year

SUBSCRIPTIONS ARE ON A PREPAID BASIS.

We are applying to the U.S. Postal Ser-  
 vice for second class mailing privi-  
 leges.

THE MAGAZINE OF INTERDISCIPLINARY COMPUTER GRAPHICS FOR  
 PROFESSIONAL GRAPHICS PEOPLE AND COMPUTER ARTISTS.

AUGUST THEME: APPLICATIONS

- 1 - FRONT COVER, "People" or "Gente" - Grau 3  
 by Waldemar Cordeiro (Deceased), Sao Paulo, Brazil
  - 4 - EDITORIAL - THE POTENTIAL OF COMPUTER GRAPHICS  
 APPLICATIONS  
 by Grace C. Hertlein  
 (Hardware vs. software — sharing, transporta-  
 bility — the real potential of applications.)
  - 5 - ENGINEERING APPLICATIONS IN THE DESIGN OF BUILDINGS  
 by Kerry Jones, American Buildings Company,  
 Eufala, Alabama  
 (An engineer discusses a series of programs used  
 by his company to produce time-saving drawings  
 and plans.)
  - 8 - SOME LINE DRAWINGS OF NEURONATOMICAL STRUCTURES  
 by Joseph J. Capowski, Department of Physiology,  
 University of North Carolina, Chapel Hill, N.C.  
 (The author illustrates teaching materials used  
 by the Physiology Department and the Neurobio-  
 logy Department at the Univ. of North Carolina,  
 and briefly discusses the hardware used.)
  - 10 - THE PHYSICS COMPUTER DEVELOPMENT PROJECT  
 by Alfred Bork, Department of Physics, Univ. of  
 California, Irvine  
 (Dr. Bork reports on the major objectives, the  
 accomplishments of the project for the past five  
 years, and he reviews the role of graphics.)
  - 17 - INVITATION: SCIENCE/TECHNOLOGY EXHIBITION  
 (The Editor issues an open invitation to artists  
 to participate in an important new touring art  
 exhibition for the Science & Technology Museums  
 of the U.S.A.)
- COUPON FOR ORDERING THE INTERDISCIPLINARY GRAPHICS  
 BIBLIOGRAPHY AND THE FORTRAN IV ART MANUAL  
 (Prices, directions, and mailing address for  
 ordering these very inexpensive reports.)
- COUPON FOR ORDERING ART REPRODUCTIONS - BONUS  
 (Address, coupon for ordering art reproductions—  
 a subscriber bonus.)
- 18 - COMPUTER GRAPHICS AND HIGH SCHOOL EDUCATION  
 by Dr. Kai Chu, Mt. Diablo High School, Concord, Ca.  
 (A former electrical engineer reports on methods  
 for teaching Data Processing using computer gra-  
 phics — and on his unique teaching methods.)
  - 23 - ANNOUNCEMENT, COMPUTER GRAPHICS AND ART
  - 24 - GRAPHICS APPLICATIONS: PAINTINGS  
 by Roger Coqart, Bruxelles, Belgium  
 (A former photographer and graphic artist illus-  
 trates his works with permutable or changing  
 squares and briefly comments on his philosophy.)
  - 26 - AN ART CHAIRMAN'S FLASHBACKS  
 by Jackie Potts, Social Security Administration,  
 Baltimore, Maryland  
 (The NCC '76 Art Chairman recalls personal anec-  
 dotes of the Art Exhibition—planning, problems,  
 and behind the scene events and dilemmas.)

# COMPUTER GRAPHICS AND ART

THE MAGAZINE OF INTERDISCIPLINARY COMPUTER GRAPHICS FOR  
PROFESSIONAL GRAPHICS PEOPLE AND COMPUTER ARTISTS.

## TABLE OF CONTENTS - CONCLUDED

28 - GRAPHICS APPLICATIONS IN THE ENVIRONMENT: GROUPE  
COULEUR DE BELFORT

by G. F. Kammerer-Luka, Belfort, France  
(The coordinator of the "Color Group" of  
Belfort reviews their involvement with  
computers and relates the work of the  
group in the Belfort community.)

34 - ANNOUNCEMENT - COMPUTERS AND PEOPLE

36 - BACK COVER, "People"  
by Waldemar Cordeiro (Deceased), Sao Paulo, Brazil!

## POTPOURRI

We hope to be changing our mailings so that  
readers will receive their magazines in a shorter  
time. Your problems in receiving late materials  
should be addressed to Judith Callahan, at the  
Newtonville Business Office address.

### FOREIGN SUBSCRIBERS

Would you like the option of paying a little  
more, to get your CG&A sent to you via faster mail?  
If so, please send a note to Judith Callahan,  
Newtonville.

### PERSONALS, POSITIONS WANTED, ETC.

We would like to try offering small, free ads  
to people, realizing that a quarterly is suited to  
specific types of advertisements. Your suggestions?

### ANNOUNCEMENTS

If you wish coverage, please send your announce-  
ments to the Editor, early! We will be happy to  
print useful material. Your ideas are most welcome.

### BOOK REVIEWS, ETC.

CG&A still needs competent book reviewers in  
varied graphic fields. Particularly desired are  
people who wish to continue reviewing on an ongoing  
basis.

### INTERDISCIPLINARY GRAPHICS BIBLIOGRAPHY CENTER

We have one university offering to be the  
Bibliography Host Center. Needed are topic/area  
bibliographers to update area materials.

### AUGUST ART ISSUE - COMPUTERS & PEOPLE

The Annual August Art Issue of Computers &  
People features its 14th Art Exposition. There  
are 30 pages of diversified art, and 70 illustra-  
tions. For copies, send \$2.00 to the Newtonville  
Business Office (see address on the masthead).

In addition to known artists, there are some  
superior works by very new people.

RIGHT OF PAGE: Detail of "Double Checkerboard" by Barbara Dwyer, Georgia State  
University, Atlanta — Randomized serial imagery from mathematical derivations.

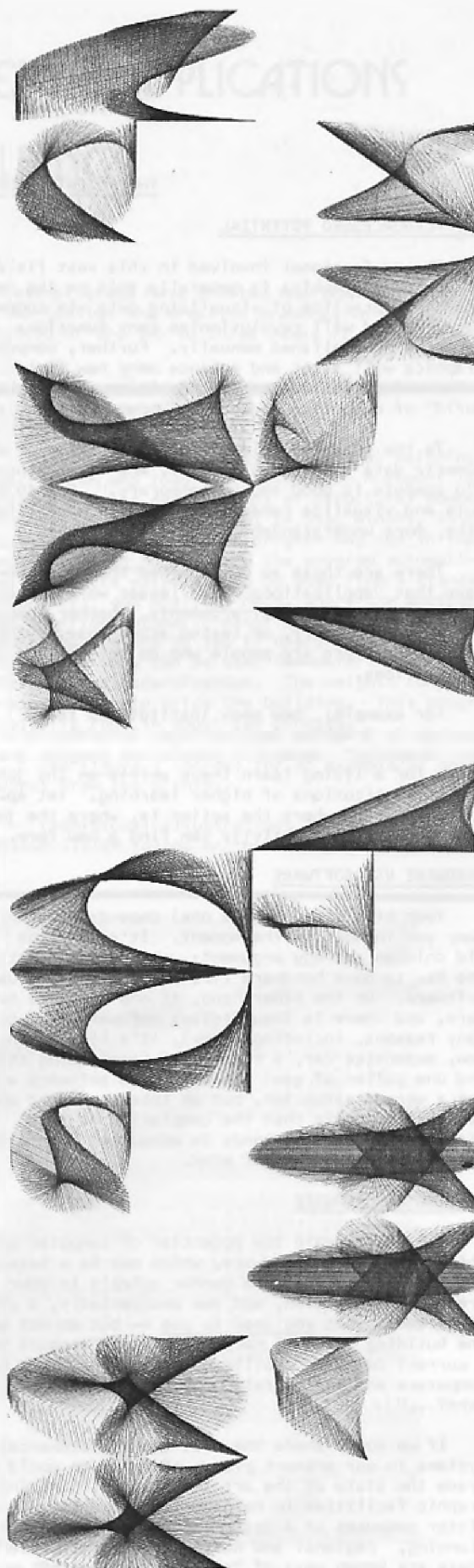

## THE POTENTIAL OF COMPUTER GRAPHICS APPLICATIONS

### THE ACKNOWLEDGED POTENTIAL

The professional involved in this vast field of computer graphics is generally sold on the idea that this practice of visualizing data via computers can and will revolutionize many functions formerly accomplished manually. Further, computer graphics will alter and enhance many new fields. A few ardent souls even believe it may "save the world" of computing, education, communication, etc.

To the graphics-uninitiated, processing of alphanumeric data appears sufficient, and their slogan is, "To compute is good and contemporary." But to compute and visualize renders information more life-like, more understandable, more communicable.

There are those so unilluminated that they believe that "applications" is a lesser word. I am reminded of the eternal arguments, whether speculation, pure theory, or tested actual use is the mightier. There are people who do not believe in applications.

For example: how many institutions teach courses in Graphics Applications, Interdisciplinary Graphics? Generally people who program graphics for a living learn these skills on the job—not in institutions of higher learning. Yet applications are where the action is, where the jobs are, and where inventivity can find a new form.

### HARDWARE VS. SOFTWARE

Your bias (if you have one) depends upon which camp you inhabit at the moment. It's like the old chicken and egg argument: which came first? One has to have hardware first — in order to use software. On the other hand, if one procures hardware, and there is insufficient software (due to many reasons, including money), it's like having a new, expensive car, a roadmap of fascinating sites, and one gallon of gas! Hardware and software are not a versus situation, but an interdependent one. It is unfortunate that the complexity of this field (of necessity) tends to encourage specialization and narrowness of mind.

### SHARING OF HARDWARE

One way to gain the potential of computer graphics is to share hardware, which may be a heresy. Did you ever go around a corner quickly in your present installation, and see unexpectedly, a piece of hardware that you need to use — but do not have? The building of small hardware empires appears to be a current computer phallic power symbol: "How many computers and peripherals do you have? How much core?..."

If we could share the cost (and maintenance) of systems in our present places of work, we would upgrade the state of the art immediately. Sharing of graphic facilities in neighboring communities, in sister campuses of a system, networking, consortia planning, regional and national graphics centers—these are known ways of "sharing the wealth".

### SHARING OF SOFTWARE

Some of the ideas on sharing, transportability, maintenance of systems, were strengthened in my mind by participation in a superior conference at the University of California, Irvine, in March of 1975. Therefore good credit is due to UC, Irvine.

Sharing implies transportability. However if we maintain our cottage industry approach, it costs a small fortune paid to vendors to achieve a sufficient level of software to make hardware do what it was intended to do. We may remain like the ancient Egyptians, forever building our private pyramids, using graduate slaves. Or...we may resemble the Babylonians (who drew maps with their city as the "center" of the universe), speaking in polyglot tongues, never understanding, never communicating what we are hoping to communicate and to achieve.

### TRANSPORTABILITY — WHY DON'T WE?

1. NIH — Perhaps the greatest, subtle flaw of mankind.
2. Need for recognition — publishing, money, fame, etc.
3. Maintenance burdens of a system upon the innovator, lack of funds, rewards, etc.
4. Lack of belief in the idea of transportability, with a large dose of #1, 2, 3 thrown in for good measure.

### WHAT IF...?

- Workshops and demonstrations replaced a portion of present conference activities?
- Manuals were sent in advance to attendees to study, so that more material could be covered in work sessions?
- Manuals were available at modest cost to those not able to attend these sessions?
- Support routines for graphics libraries were available in varied forms at low cost?
- A registry of programs, researchers, etc. was available from a Graphics Center?
- We worked with CONDUIT, SIGGRAPH, ACM, the Council on Social Graphics, our regional consortia, etc.?

The potential is there. The state of the art of computer graphics applications could greatly be enhanced by common, known solutions, without the benefit of great grants and feasibility studies, etc. What if...?

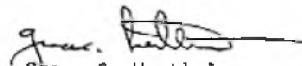
  
Grace C. Hertlein  
Editor

# ENGINEERING APPLICATIONS IN THE DESIGN OF BUILDINGS

by Kerry Jones  
American Buildings Company  
Eufaula, Alabama 36027

"These programs have enabled American Buildings to produce fabrication and erection drawings in one to two days, instead of the two to three weeks it took manually."

AUTO/STEEL is a series of programs used by engineers as an aid in designing metal buildings. The system produces drawings used to fabricate and erect the building.

The system was written in FORTRAN and has been implemented by our company on the following computers: IBM 1130, XEROX Sigma 3, and IBM 370. Plotting hardware is currently two CalComp plotters and controllers, both used offline.

## THE SYSTEM

The system consists of four programs — DESIGN, DETAIL, DRAFT, and ERECT. The DESIGN program was written by Dr. Krishna Murthy of Vanderbilt University. The systems analysis phase of the other three programs was a joint effort between American Buildings Company and Synercom Technology, Incorporated. The programs were then written and installed by Synercom.

## DESIGN — HOW IT WORKS

"DESIGN" accepts as input a general building description and loading conditions. A report is printed showing descriptions of structural members, including the type of steel to use, widths, thicknesses, and depths. This program may run in two modes: Design Mode, where the program automatically selects materials to be used from a standard inventory; and Analysis Mode, where the engineer can override automatic material selection, and change parameters to see if design criteria are met. This mode can be used for material optimization and standardization. The weights computed are used to help price the building. This program typically runs in about two minutes.

See Figure 1 (below) for an example of design output from the printer.

(Additional illustrations and details of the DESIGN SYSTEM follow on the next page.)

AMERICAN BUILDINGS COMPANY  
EUFULA -- ALABAMA  
07/02/76

BUILDING DESCRIPTION -- STD RIGID FRAME (REF: 8016-25)

RIGID FRAME ANALYSIS AND DESIGN BY DIRECT STIFFNESS METHOD.  
ALL DESIGN IN ACCORDANCE WITH AISC AND MBMA AS APPLICABLE.

BUILDING WIDTH	=	20.00 FT.	BAY SPACING	=	25.00 FT.
EAVE HT. (LEFT)	=	15.83 FT.	ROOF SLOPE (LEFT)	=	1.00 IN./FT.
EAVE HT. (RIGHT)	=	15.83 FT.	ROOF SLOPE (RIGHT)	=	1.00 IN./FT.
PURLIN DEPTH	=	8.00 IN.	GIRT DEPTH	=	6.00 IN.
PURLIN SPACING	=	60.00 IN.	GIRT SPACING	=	48.00 IN.

NODE LOCATIONS (DISTANCES TO OUTER FLANGE POINTS)				INPUT DEPTH	
NODE	X DISTANCE	Y DISTANCE			
1	0.50 FT.	0.00 FT.	LEFT BASE	10.000 IN.	
2	0.50 FT.	15.21 FT.	LEFT KNEE	36.000, 36.000	
3	7.50 FT.	15.82 FT.	LEFT RAFTER	27.987 IN.	
4	15.45 FT.	16.49 FT.	LEFT RAFTER	19.000 IN.	
5	25.93 FT.	17.32 FT.	LEFT RAFTER	19.019 IN.	
6	40.00 FT.	18.50 FT.	RIDGE	26.000, 26.000	
7	54.07 FT.	17.32 FT.	RIGHT RAFTER	19.019 IN.	
8	64.05 FT.	16.49 FT.	RIGHT RAFTER	14.000 IN.	
9	72.10 FT.	15.82 FT.	RIGHT RAFTER	27.987 IN.	
10	75.50 FT.	15.21 FT.	RIGHT KNEE	36.000, 36.000	
11	79.50 FT.	0.00 FT.	RIGHT BASE	10.000 IN.	

(NOTE-- FLANGE THICKNESS ASSUMED 0.5 IN. TO LOCATE FRAME OUTER LINE.  
X DISTANCES FROM LEFT GIRT LINE, Y DISTANCES FROM LEFT COLUMN BASE.)

LATERAL SUPPORT CONDITIONS FOR STEEL WALL COLUMNS --  
LEFT COLUMN, OPEN TO 7.30 FT. HEIGHT  
RIGHT COLUMN, OPEN TO 7.30 FT. HEIGHT

STEEL YIELD STRESSES --  
50.00 KSI FOR BUILT-UP SHAPES  
36.00 KSI FOR PIPE COLUMNS

Figure 1. Design output from the printer.

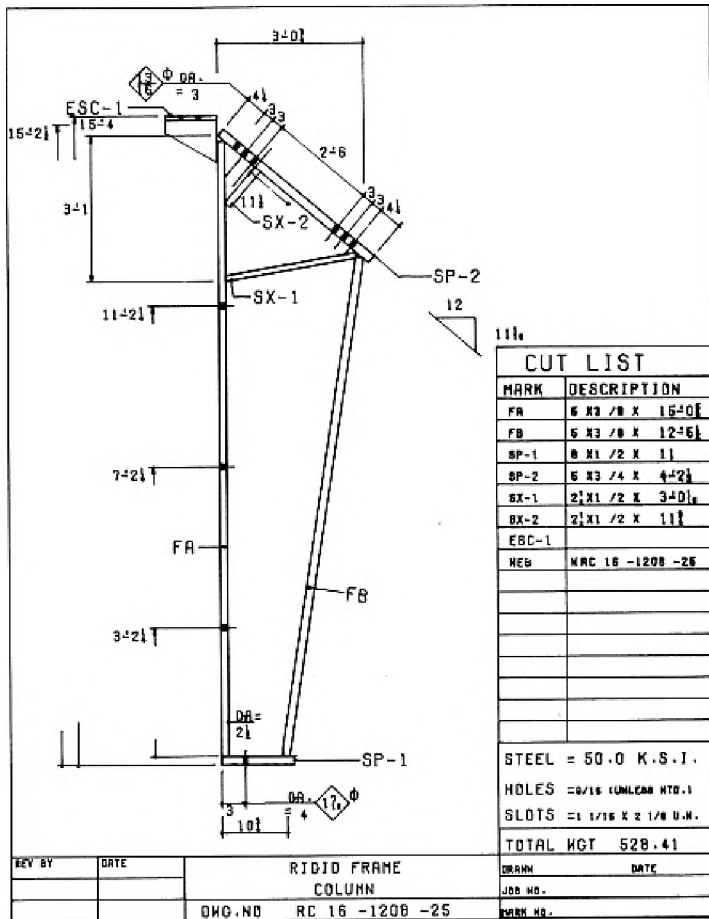

Figure 2. Above.

"DETAIL" does most of the major calculations for DRAFT, and prints a report describing the drawings to be produced. Input is from the DESIGN program. Typical run time is less than two minutes.

"DRAFT" draws 8.5 X 11 inch drawings (reduced in the illustration at the left), used by our shop to fabricate primary structural components. The drawings show dimensions of components, locations of holes and types of materials to be used. This program typically runs in three to nine minutes. See Figure 2 (left) for an illustration of DRAFT.

"ERECT" uses data produced by DESIGN and DETAIL, plus other data entered by the engineer (Figure 3), to produce drawings sent to the field to aid in the erection of the building. Drawings produced include:

1. Reaction schematics showing stresses that the concrete slab must withstand;
2. An anchor bolt plan, showing where bolts are to be imbedded in the concrete slab to anchor the building;
3. A cross section;
4. A framing plan showing where the frame components are to be located;
5. A sheeting plan showing where the sheet metal is to be attached to the sides. (See Figure 4, below, also reduced in size photographically.) This program typically runs in six minutes.

Synecom Technology, Inc.

SH. 1 OF 10

AUTO-STEEL  
ERECT

PROJECT ANALYST \_\_\_\_\_ DATE \_\_\_\_\_

**JOB IDENTIFICATION AND HEADING INFORMATION**

1	2	3	4	5	6	7	8	9	10	11	12	13	14	15	16	17	18	19	20	21	22	23	24	25	26	27	28	29	30	31	32	33	34	35	36	37	38	39	40	41	42	43	44	45	46	47	48	49	50	51	52	53	54	55	56	57	58	59	60	61	62	63	64	65	66	67	68	69	70	71	72	73	74	75	76	77	78	79	80	81	82	83	84	85	86	87	88	89	90	91	92	93	94	95	96	97	98	99	100
- CUSTOMER -										- CODER -										"BUILDING DESCRIPTION"																																																																															
ERECTOR DRAWINGS										L.R.F.C.										8016-25																																																																															
- CITY, STATE -										- DETAILER -																																																																																									
10' SPAN										11' EAVE										7' 0" PLATE																																																																															
- DEALER -										- JOB NO. -																																																																																									
20' LIVE LOAD										25' WIND LOAD										25' BAYS																																																																															

**OPTIONS DATA**

Building Type	Cross Partition Column Lines	Symmetry Code	# of End Wall Frame Plans	# of Slope Wall Frame Plans	# of Distinct Frame Types	# of Width Extensions	# of Other Structures	# of Bays	OPTIONS	Frame reaction types	# of Left End Wall Columns	# of Right End Wall Columns	# of Braced Beams	End Wall Frame Code	# of Side Wall Columns	# of End Wall Connections
1	1	1	1	1	1	1	1	1	0	1	1	1	1	1	1	1

Building Type: MAIN OR WEST (FOR LEAN-TO)

Symmetry Code: 0 = Symm, 1 = Non-Symm OF LEAN-TO

Options: 44- Roof Framing, 45- Wall Framing, 46- Cross Section, 47- Endwall Panel, 48- Anchor Bolt, 49- Printer Report, 50- Diagnostic Output, 51- DETAIL/ERECT Interface (0 IF LEAN-TO), 52- Title Block, 53- Input in Inches

Endwall Frame Code: 1-R.Frm., Solid, 2-R.Frm., Opn Below Gab, 3-R.Frm., Opn Below Gab, Stub Col, 4-R.Frm., Opn, 5-Col/Beam, Solid, 6-Col/Beam, Opn Below Gab, 7-Col/Beam, Opn, 8-Opn Endwall

Above: Figure 3. A coding sheet and data entered by the engineer, to produce field drawings.

# CROSS SECTION

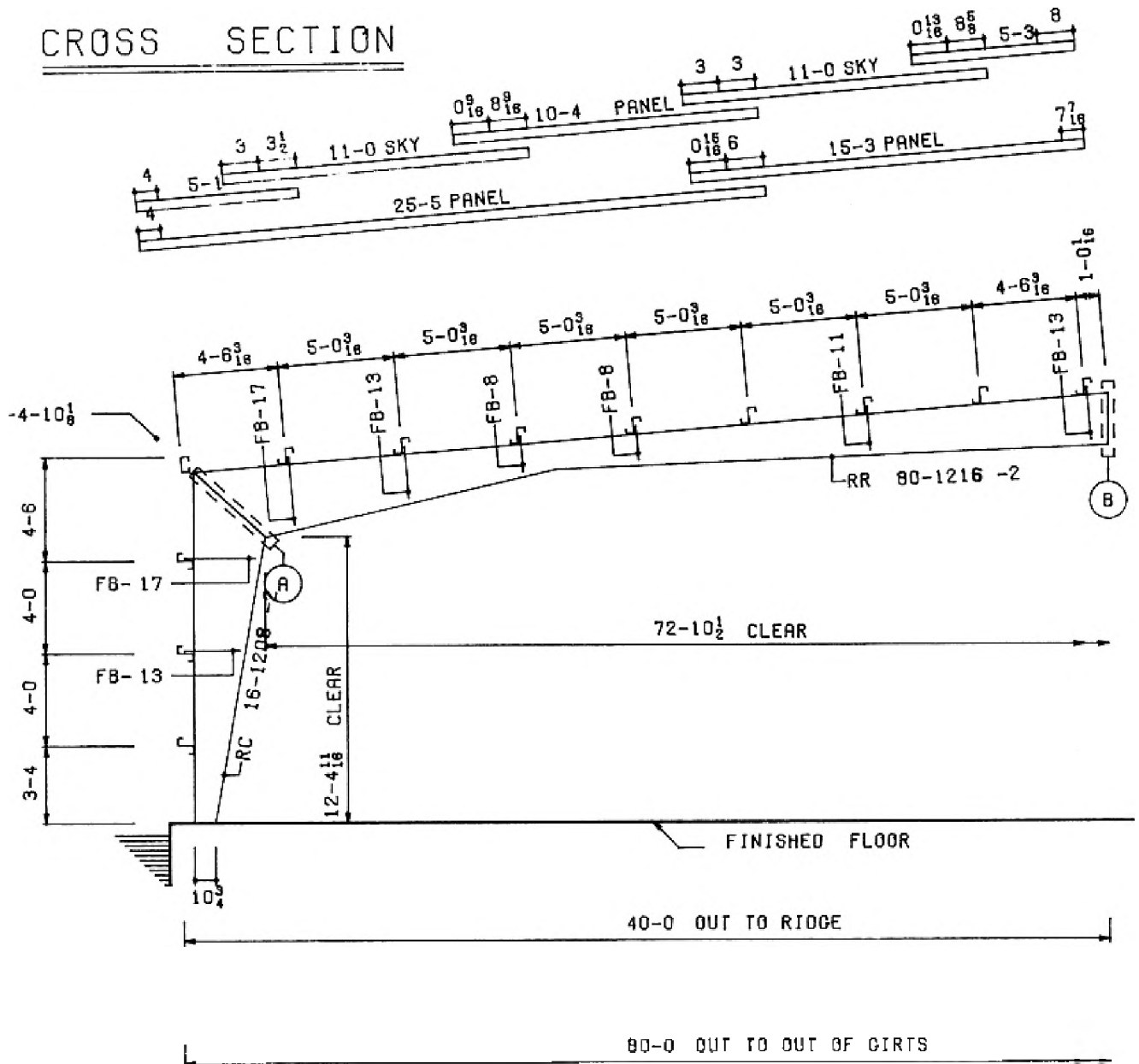

Above: Figure 4. A detail (partial drawing) of a sheeting plan showing where the sheet metal is to be attached to the sides.

## THE TIME WE SAVE USING THIS SYSTEM

These programs have enabled American Buildings to produce fabrication and erection drawings in one or two days instead of the two to three weeks that it took manually to accomplish the needed work.

One fine example of the system's capabilities occurred when a conventional building belonging to one of our dealers burned down. The fire was reported to the Home Office on a Friday morning, and the design of a replacement building was requested.

A complete set of detail drawings was finished on Saturday. Without the automated system, the engineering and detailing jobs would have taken at least a week and a half.

SPlice Bolt Table		
SPlice	NO-SIZE	DEPTH
A	12-0 $\frac{3}{4}$ X 2 $\frac{3}{4}$	3-0 $\frac{3}{4}$
B	8-0 $\frac{3}{4}$ X 2 $\frac{3}{4}$	2-2 $\frac{6}{8}$

## PRESENT AND FUTURE PLANS

We are currently converting AUTO/STEEL to the metric system for a European metal building manufacturer.

Plans for the future include increasing the flexibility of our designs, and implementing interactive online building design.

# Some Line Drawings of Neuroanatomical Structures

by Joseph J. Capowski  
Department of Physiology  
University of North Carolina  
Chapel Hill, North Carolina 27514

"These displays enable the anatomist to qualitatively classify structures or to confirm anatomical feature distribution theories."

The Physiology Department and the Neurobiology Program at the University of North Carolina have a Computer Center built upon a DEC PDP-11/45 CPU and an Evans and Sutherland LDS-2 Line Drawing System. The Computer Center is used for the collection and analysis of neurophysiological and neuroanatomical data.

Neuroanatomical data is collected by the computer system primarily through a data tablet and a microscope, which are attached to the PDP-11/45. The LDS-2 generates line drawings of the data, which are collected. These displays enable the anatomist to qualitatively study structural relationships. Then several types of statistical summaries of anatomical features are generated in order to quantitatively classify structures, or to confirm anatomical feature distribution theories.

In the illustrations which follow, some of the more spectacular three-dimensional line drawings are presented and discussed. Each figure is composed of up to about 2000 short lines. The display is presented by the LDS-2 on a 17 inch Hewlett-Packard CRT. Each figure can be smoothly rotated and translated in real time. When the viewer is satisfied with the display, he may request a hard copy on a Hewlett-Packard 7210A plotter. The figures shown are untouched photographs of plotter output.

I am indebted to Helena Jones, National Institute of Environmental Health Sciences, Research Triangle Park, North Carolina, for the use of her hagfish brain data, and to Miklos Rethelyi, 2nd Department of Anatomy, Semmelweis University Medical School, Budapest, Hungary, for the use of his neuron tree data.

BELOW: Figure 1 — The outline of a hagfish brain. This figure is composed of 15 brain cross sections, each traced into the computer on a two-dimensional data tablet. Microscope slide sections were projected onto the data tablet, and the features of interest were traced by hand. The PDP-11 reconstructed the three dimensional model.

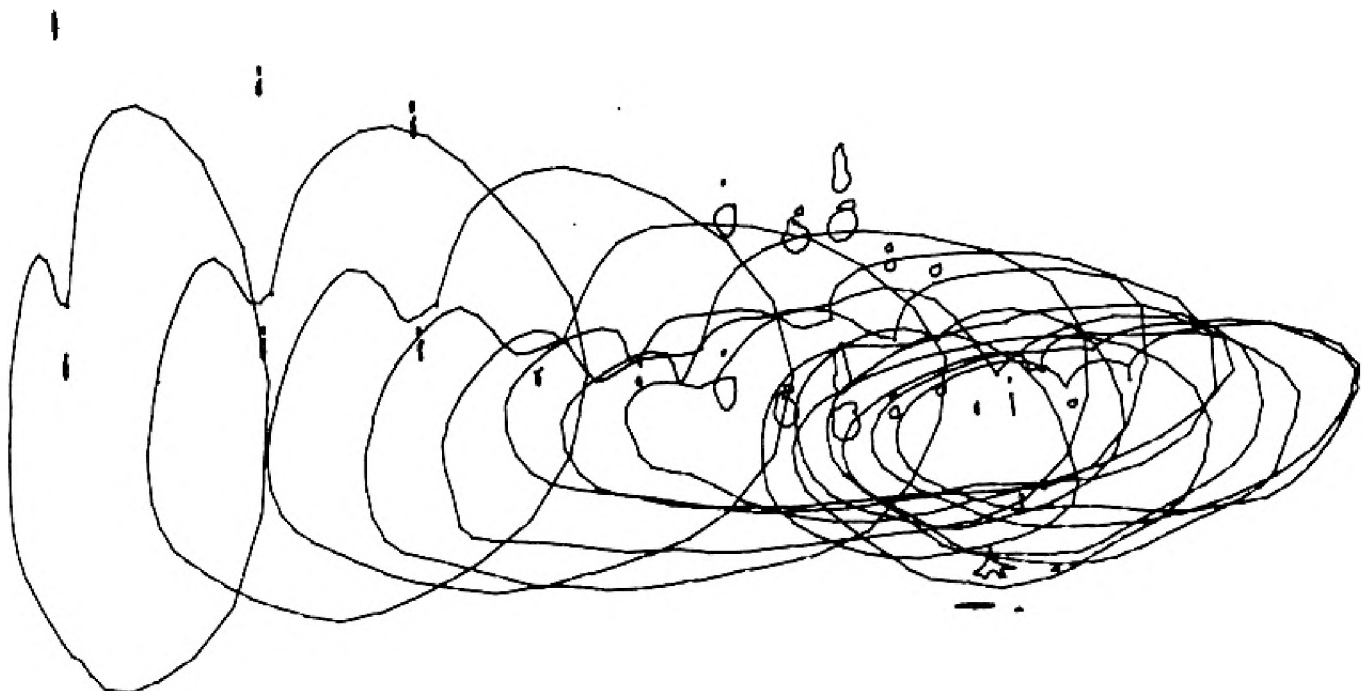

L41701

RX 000 RY 000

RZ 000

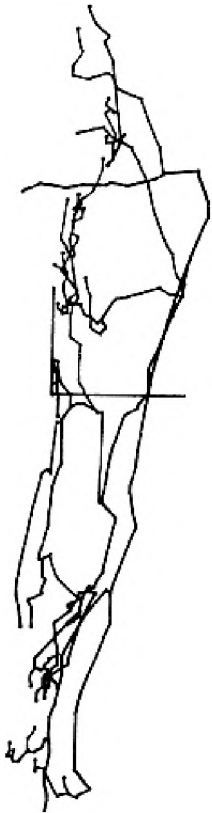

Figure 2.

RX 000 RY 000

RZ 000

L41701

L41702

L41703

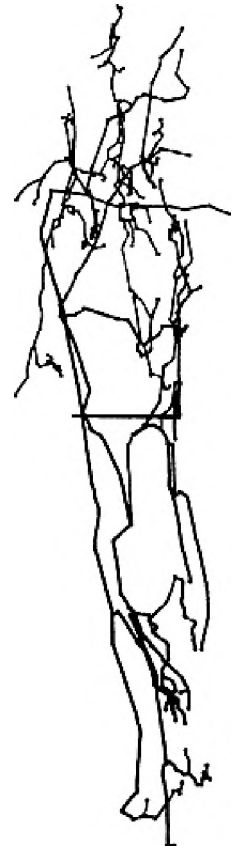

Figure 3.

LEFT: Figure 2 -- A neuron (nerve cell) axon tree in the dorsal horn region of the spinal cord of a cat. The stem fiber enters the dorsal horn at the left end of the horizontal line near the top of the structure. The stem fiber divides many times, and small branches end in terminals and en passant enlargements where electrical activity to other neurons occurs.

This tree was input through the microscope into the computer. The anatomist focused each part of the tree under the microscope cross hairs; the computer recorded the coordinates of each point. This display is an orthographic projection of the three dimensional model after no rotation about any axis. The "L" in the middle of the display represents 100,um in each direction.

RIGHT: Figure 3 -- The axon tree of the same neuron shown in Figure 2 (left). The cell has been rotated 143 degrees about the Y axis of the CRT. Two other neuron trees in close proximity are also shown.

L41404

L41403

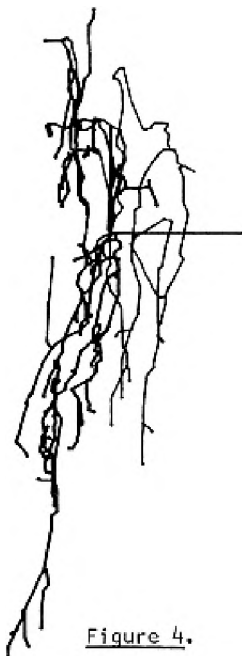

Figure 4.

RX 000 RY 143

RZ 000

L41404

L41403

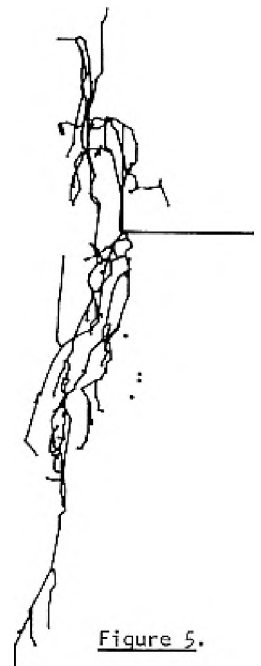

Figure 5.

RX 000 RY 000

RZ 000

# The Physics Computer Development Project

by Dr. Alfred Bork  
Department of Physics  
University of California  
Irvine, California 92717

"During the last six years, with support from the National Science Foundation and the University of California, the Physics Computer Development Project has been engaged in the development of computer-based teaching material in a wide variety of modes. The director is Alfred Bork; the codirectors are Richard Ballard and Joe Marasco. This report reviews the work of the group and discusses the directions of present activities."

## OBJECTIVES

The Project has five major objectives:

I - First, and foremost, the Project aims to produce compelling examples of effective use of the computer in learning situations, primarily in physics and the other sciences, at the undergraduate level. We did not begin with a restricted view of just how the computer was to be used, based on philosophical considerations; rather, we hoped to employ the computer in a wide variety of modes, appropriate to the pedagogical problems encountered. We have never intended to teach entire courses by means of computers, but rather to choose those uses

most effective for the area and the student; we assume that other teaching media will also be involved. This directive implies that we do not begin by asking, "What program shall we write?"; to the contrary, we ask, "What are the difficult but important learning problems in this area?" Another implication is that the interactive programs — dialogs — should not force students to adapt to the requirements of the program, but should allow students to behave in fashions more natural to them; the dialogs should be highly responsive to student needs and inputs.

II - A second major objective is to explore the use of graphics in computer-based teaching materials. Early computer use in education was seldom pictorial, because the input-output equipment, resembling typewriters, allowed only crude visual presentations. Visual information provides an alternative to alpha-numeric information, and so provides unique learning advantages. A graphic sequence can be dynamically dependent on students' requests and responses, allowing possibilities not available in films. Discovery and development of effective visual dialogs was and is a major goal of this project. Further, these same graphic facilities are important for student problem solving.

III - The third major objective of the Physics Computer Development Project is to explore authoring modes. If sizable bodies of learning sequences on the computer are to be produced, many teachers should be involved. We can expect highly successful teachers to be more than usually effective in authoring student-computer dialogs. Many of these excellent teachers can see the learning potentials of the computer, but few are interested in taking the time to learn computer languages, techniques, and operating systems. So we raise three questions: (1) How can these good teachers be persuaded to develop computer-based material? (2) How can

Below: Students gather informally in the terminal room to share ideas in an atmosphere that provides not only interaction with graphics and dialogs, but with other human beings.



they be provided with the resources, facilities, and assistance to ease the task? What institutional structures will encourage dialog preparation, both organizational structures and reward structures?

IV - The fourth objective is to introduce dialogs and other computer approaches into standard undergraduate environments. We wanted to work with large classes. The problems are partially political. Faculty members tend to be conservative with regard to new teaching techniques. The standard texts do not acknowledge the existence of computers; they are a powerful conservative force inhibiting computer use. New problems arise as the material is used in schools other than the original one, problems which are to only a small degree dependent on hardware differences.

Finally, the project sought a software strategy consistent with the above goals. The software approach needs to be highly flexible so that it can grow because of the pedagogical demands of good teachers serving as authors. It should allow full graphic capability. It should allow users all the resources of the computer. It should produce self-documented programs which are easy to read and to modify. As the major objective is the production of effective dialogs, software development is to be undertaken only when necessary. Existing software is to be used as far as possible.

It should be noted that the Physics Computer Development Project has not so far attempted to develop any computer hardware. Rather we have worked with existing computers and terminals. Further, we have avoided developing operating systems or full languages. We have, however, attempted to influence vendors to modify their products to make them more useful in educational environments.

#### PROGRESS AND PROBLEMS

The Project has made steady progress toward the goals outlined. The results will be outlined in the next section. We received a small setback just before the initial grant was received. The proposal assumed computer equipment then available on the Irvine campus, but the University changed computing facilities. So the graphic software we planned on could not be employed. However, the new computer, a Xerox Sigma 7, has proven to be an excellent machine for our purposes. It has a full-scale efficient timesharing system, with good debugging facilities. A few software problems still exist, and we are working with Xerox to solve them.

Commercial development of inexpensive graphic terminals also proceeded more slowly than we would have preferred. Most terminal vendors are concerned primarily with the commercial market, so they are not always responsive to educational needs. But we have been able to work with several vendors, and the terminal situation has greatly improved. Tektronix has proven to be particularly amenable to advice

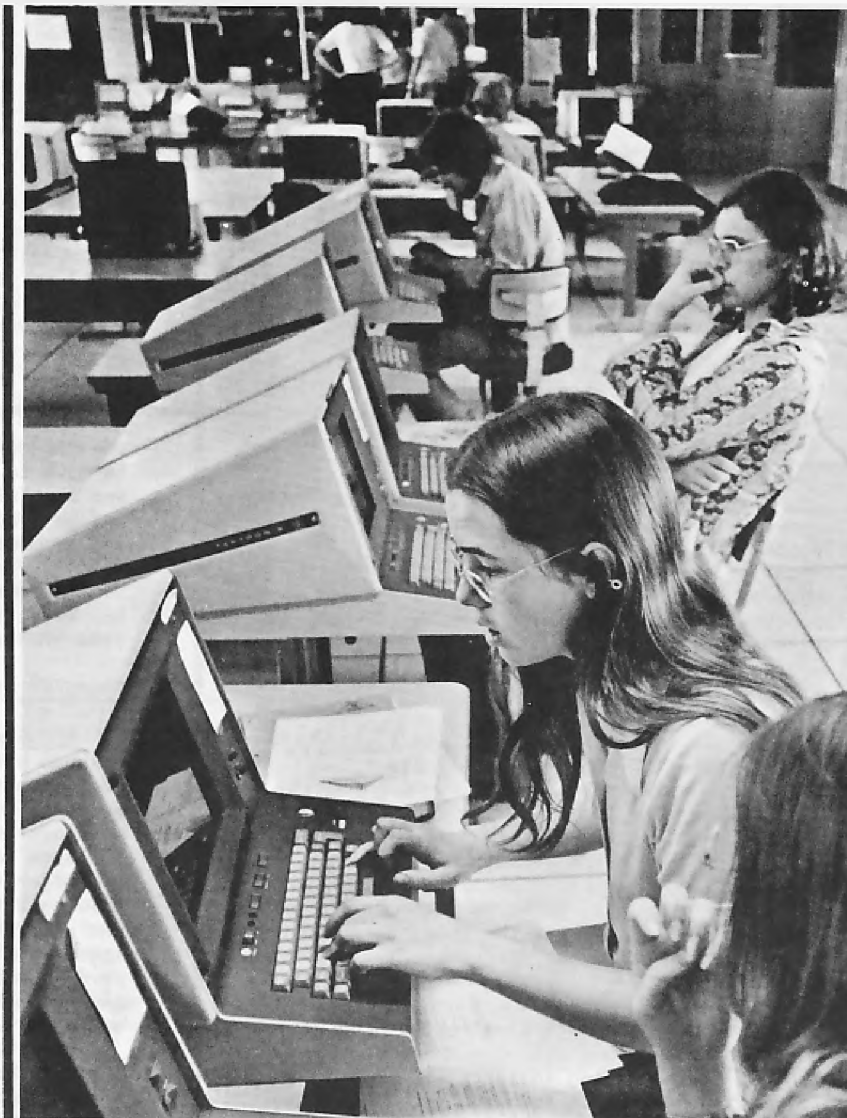

Above: Students interact with the varied dialogs, observing graphic patterns on Tektronix screens with a great range of reactions: intense observation; looking at the patterns on a neighboring screen; and an attitude resembling "meditation".

from the educational community. The University now owns about thirty Tektronix 4013s allowing PCDP material to be widely used.

#### RESULTS

The principal products of the Physics Computer Development Project are the dialogs, the graphic additions to APL, the underlying software, and the authoring system.

Dialogs - Producing science teaching dialogs is the Project's major activity. Students are now using about thirty-five dialogs; many are currently under development. Brief descriptions of the dialogs are listed in PHYSICS DIALOGS FOR STUDENT USE, available on request. Some dialogs have been discarded, as ineffective; an idea which seems good in advance will sometimes prove to be of little value to students. Early dialogs employ no visuals, as we initially had no graphic displays, but recent dialogs use graphics extensively. Many of the dialogs fit into a few distinctive pedagogical classes, areas where we believe the computer to be particularly effective.

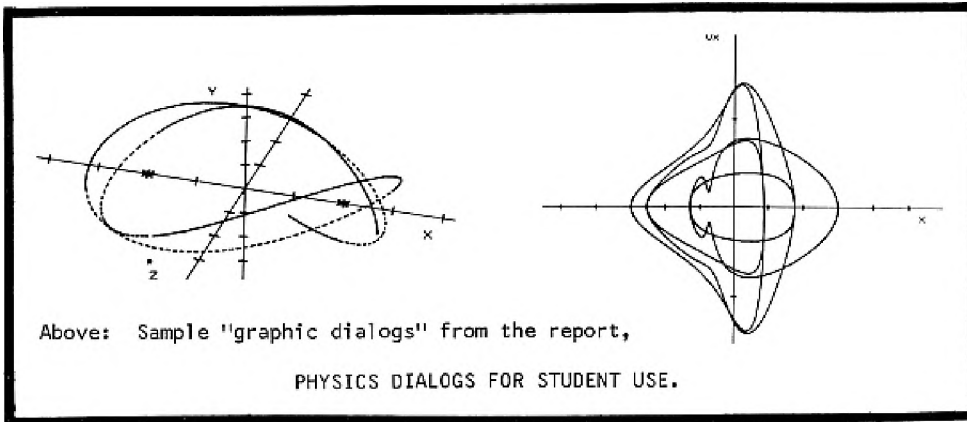

Above: Sample "graphic dialogs" from the report,  
PHYSICS DIALOGS FOR STUDENT USE.

One major learning problem is developing problem-solving abilities. Conventional teaching often is not effective in developing this skill, important in all areas of science. We have pursued several types of dialogs seeking to aid students in solving problems. Several dialogs (such as DOPPLER) are designed to assist with homework problems; each is devised for a specific problem that the student has not been able to solve, helping not only with that problem but teaching something of the heuristics of problem-solving. Another type, the interactive proof dialog, (COUPOSC is an example) tries to make the major derivations of the text or lecture a more active experience for students. Instead of the typical passive experience, students attempt the critical decisions in the proof, receiving help where necessary. A third possibility, little explored but offering promise, gives an incompletely defined problem and obliges the student to request the missing information; help can also be offered in the process.

A second major objective in learning, also difficult to approach with conventional teaching methods, is developing insight; in physics we are more successful in teaching techniques than in developing intuition about the behavior of the physical world. Experience is essential in developing insight and intuition. A dialog such as MOTION creates an interactive world for students; they can move about freely, exploring the effects of the laws of mechanics in a variety of abstract spaces. We can give students a range of experiences unobtainable in everyday life or in the laboratory, and so aid in developing insight. Graphics, pictorial information, is vitally important in this process.

Forming useful concepts is another intellectual activity, related to the two just discussed. In a suitable structured computer environment students can grope toward key ideas, for which definitions might be "given" in a more traditional situation. Thus, in the dialog 3D students achieve the concepts of divergence, curl, and gradient by "seeing" them as generalizations of the concept of ordinary derivative. The "names" are introduced only after the "ideas" are understood.

Other dialogs are less easy to classify. LUNA and TERRA attempt to teach a critical idea,

that of the nature of a scientific model. We have developed several game-like dialogs, useful for motivation; but we are only slowly learning how to write games which also provide a learning experience. Perhaps the best such dialog game is FERM, introducing the important idea of a minimal principle.

Two incomplete dialogs, QUANTUM and SPACE, explore new and interesting directions. Both allow considerable student control of

the flow of the program, permitting the student to move to new areas and tasks, but both maintain and use full information on what students do. We are continuing their development; they are serving as models for future work.

These and other types of dialogs are reviewed in "Effective Computer Use in Physics Education". (See bibliography.)

#### COMPUTER USE IN PHYSICS EDUCATION

APL Graphics - In addition to preparing dialogs, we have also investigated problem solving by computer, with students writing programs, in standard programming languages, to solve problems in homework assignments. About one-half of student usage in large courses is devoted to this mode of use. One major advance in using computers for problem solving has been to provide students, for their own use, the graphic capabilities present in dialogs. In the process of developing our graphic material we have been able to successfully influence the products of both a terminal vendor (Tektronix) and a main-frame vendor (Xerox).

After a review of languages, we decided that APL was a superior problem-solving language for undergraduates in science and engineering. So we added graphic capability to APL, in a manner natural to the language. This facility is now in widespread use not only at Irvine, but in many other locations with XEROX computers. We also developed very effective material, "Ten Finger APL", for learning both the non-graphic and graphic capabilities of APL. The approach does not involve lectures, reading, or dialogs; the student enters APL and observes the behavior of the computer as specified statements are entered.

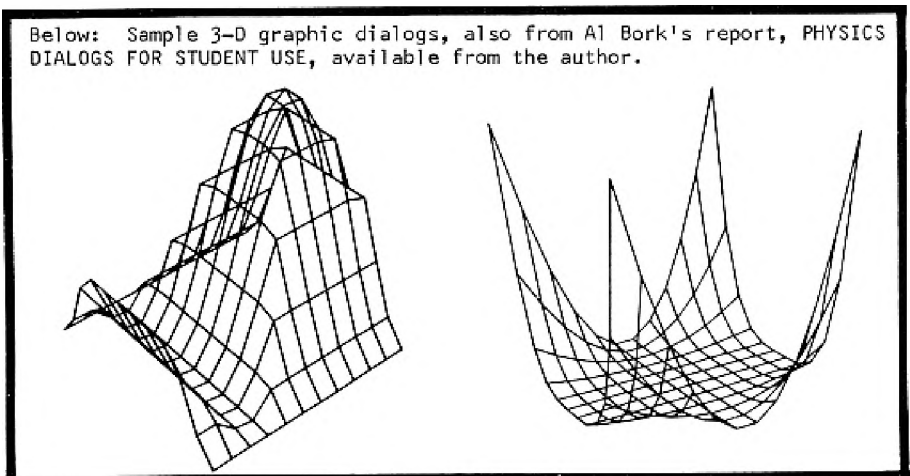

Below: Sample 3-D graphic dialogs, also from Al Bork's report, PHYSICS DIALOGS FOR STUDENT USE, available from the author.

The graphic software is based on the powerful facilities available in APL for handling collections of numbers. We added a new output operator, quad zero. It produces, when assigned a data structure interpretable as graphic data, pictorial output. The system is further described in "APL as a Language for Interactive Graphics". (Please see references.)

Dialog Software - The software goals have been outlined. We chose to base development on assembly macros, writing new macros in response to pedagogical needs. These macros (in Metasymbol on the Xerox Sigma 7) have English names, and have only a few arguments, to aid in readability of source code and to make the task of computer entry easier for secretaries. The macros usually write only a few instructions in-line; much of the work is accomplished in subroutines, stored in a library. We write new macros when new teaching facilities are needed.

Programs also contain FORTRAN segments where needed, particularly for calculational purposes. We also make heavy use of the overlay facilities of the loader, as many of the dialogs are much too large to fit into the core available to a time-sharing user. Full documentation of the software is available.

Dialog Preparation - In addition to the useful dialogs that our Project has produced - teaching materials that we believe are as effective as any in wide student use developed anywhere in the world, we have made important innovations in the process of preparing such material.

The key person in the preparation of learning sequences is the competent teacher with experience and insight into the learning process. Hence, the first problem in producing computer-based teaching materials is to identify and to involve such teachers, even though they may have had little previous interest in this particular process. Many outstanding teachers from Irvine and elsewhere have been associated with us. Undergraduates who have shown insight into assisting others in learning have also produced some dialogs.

The teachers who have prepared our materials have very different teaching philosophies; it is no secret that good teachers disagree highly about just how to teach effectively. As a project, we favor no single teaching style or philosophy. Different programs reflect different points of view, even in the same area. Only through additional research and testing of materials in the student "marketplace", with large numbers of students, can we decide the relative validities of varying approaches. Probably each dialog will work in some situations, given the diversity of learning strategies used by students.

Competent teachers may have little direct interest in the computer. They can be highly interested in the possibilities if they see a device which can assist learning, however. We must convince such a person that the computer has unique teaching capabilities, and then provide a mechanism whereby teachers can generate dialogs without becoming computer experts, or even computer novices. To stimulate interest in the computer as a learning medium, demonstration is very effective; it is useful to show teachers a variety of materials already developed, with a running discussion of the limitations of the medium and individual decisions on the part of the author. We offer many such demonstrations each year. These demonstrations need not be

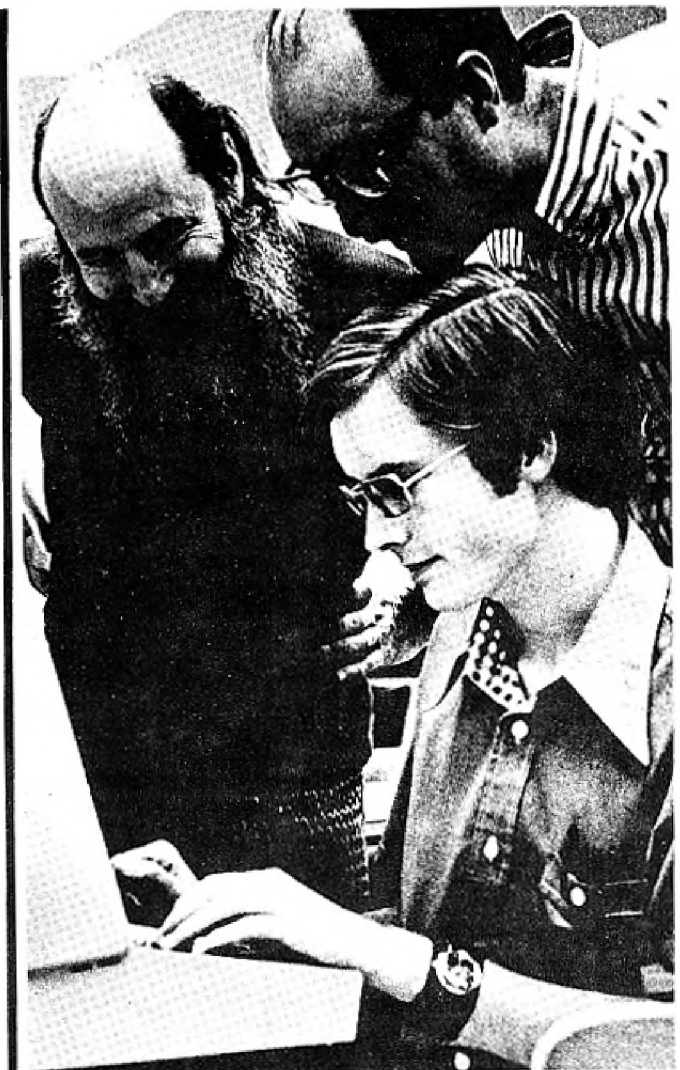

Above: Dialogs elicit intense, interested (and almost joyous responses) from Al Bork, Richard Ballard, and Marty Geisort.

given at Irvine. The Project has often given talks and demonstrations on other college and university campuses, and so many instructors have viewed our dialogs through long distance phone conversations with the computer. We are developing additional facilities for remote exhibitions of our dialogs and approach.

We have a very satisfactory mechanism which obviates instructors from learning computer languages and becoming computer experts. We do not require that dialog writers learn any one computer language or technique, or that they learn the particular details of our operating system. Instead they describe pedagogically how the sequence is to proceed, and we take responsibility for getting the program running. We encourage dialog writers to think freely about the possibilities; we may tell them if a program facility is technically unfeasible or too time consuming. But in most cases we can provide the computer facilities the authors require, even if we have not previously needed such a facility. Most of our authors write in a loose flowchart format.

The technique varies from author to author. An experience Project member aids in early stages of preparing dialogs. An author can develop a complete

pedagogical specification of a sizable chunk of material in a week, given the help of an experienced person for the first few hours. This method allows teachers to do what they can do best — teaching. It also precludes their spending weeks learning a programming language. But if an author is particularly interested in computer details, he or she can write programs directly.

The second stage in dialog preparation is entering the material, usually by a secretary or student programmer. We teach the person to work at a terminal directly from the flowchart, using a simple editing system on the Xerox Sigma 7, and we also teach a few widely used dialog commands. The process of training the secretary takes only a few hours, with the person working more and more alone the last few hours, with only slight backup. We can train most competent secretaries. The process is no more difficult than operating an electronic typewriter and secretaries see the job of entering computer material to be similar to using such word-processing equipment. Any area which cannot be handled is indicated by comment lines in the program. Secretaries also learn to make corrections and modifications.

The third stage involves programmers, often students, who know the full range of our software dialog facilities; they produce a working program. There may be problems with what the secretary typed, but the main task is to program parts too difficult for the secretary. Programmers write FORTRAN segments if needed, assemble dialog pieces, compile FORTRAN segments, and produce load modules. Graphic coding has presented numerous problems, particularly in complex mixtures of pictures and texts. In many of our recent dialogs, with heavy emphasis on visual presentations, graphic coding is about 75% of the total programming task.

Recently, we have developed some interactive APL facilities to aid in the production of the graphic portions of dialogs. These facilities allow the author or programmer to "design" pictures, including associated alphanumeric information, directly at the terminal, using the graphic input crosshairs. Segments, either pictorial or alphanumeric, can be named, combined, and moved around on the screen. The program then writes the graphic macros required, and puts them in a file. In some situations, dramatic reductions in programming time are possible.

#### WORKING WITH OTHER SCHOOLS

We are also very interested in the process of transferring our materials to other campuses. The



Above: UC faculty explore writing new dialogs for the system. Douglas McCollm, UC, Davis; John Sonquist, UC, Santa Barbara, part of the University of California Summer Workshop.

problems are great; they include not only the classical difficulties of transporting software, but also the issues always involved in educational innovation. Our emphasis is on the second group of problems, although we have worked with several groups interested in moving our software to other computers.

Some use of our dialogs is currently taking place on a limited basis, from many schools in our area including Community Colleges and campuses of the California State University and Colleges; these schools access the Irvine computer through the phone system. Because of financial and other considerations, this use is still limited. We have also sent programs to other schools with Xerox computer equipment, and offered assistance in getting these programs operable.

Of particular interest to us is increasing cooperation within the University of California. With support from the University we directed a workshop in the summer of 1974 for four physics faculty members from four other University of California campuses (Riverside, Santa Cruz, Davis, and Santa Barbara). The grant also supported terminal acquisition and computer time. In addition to becoming familiar with existing material, each person prepared a new dialog. But no extensive student use is possible because the funds are not

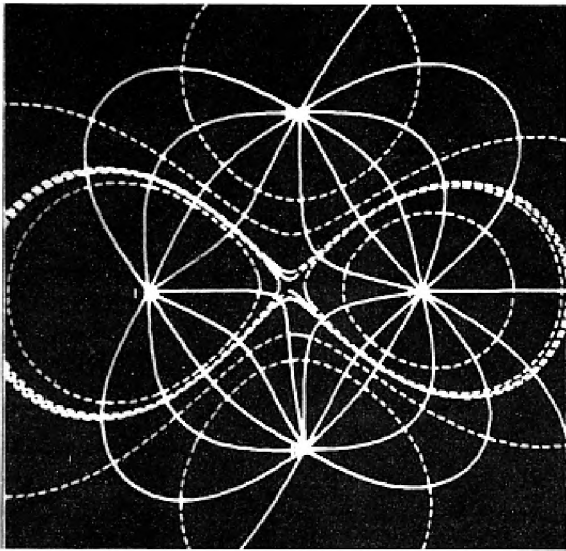

Above: Photographic reversal of another sample graphic from the report, PHYSICS DIALOGS FOR STUDENT USE.

large. A further activity involves the development of some modules for physics courses.

Several new suggestions the the University will, we believe, lead to greatly increased use on other University of California campuses. One is the establishment of an Organized Research Unit in Educational Technology. This center would serve to focus developmental activity and would provide a limited amount of continued support from the University. It might evolve into the type of larger center portrayed in The Carnegie Commission report, "The Fourth Revolution — Instructional Technology in Higher Education".

Another suggestion directly addresses the availability of computer facilities. It proposes to make available a single timesharing computer for science teaching on all eight undergraduate campuses of the University of California. This computer would not support research and administrative use, but would be devoted to education. The PCOP materials, and soon other materials, would be available throughout the University, and faculty members on other campuses would join us in the preparation of new materials, leading to an order of magnitude increase in the number of dialogs available. This model, too, works toward the ideas presented in the Carnegie Commission report.

#### NEW DIRECTIONS

Recent renewed support from the National Science Foundation allows us not only to pursue some of the programs already suggested, but also allows several new approaches.

In developing dialogs such as QUANTUM we have uncovered organizational strategies which allow greater student control over the flow of the program, strategies which are largely independent of the subject area. The work has been undertaken by one of the codirectors of the project, Richard Ballard. The basic notion is a two-stage program for understanding student input; if the local testing (looking for response to a specific question) fails, the program goes to a higher level and tests

to see if the student wants to change the topic, request a definition, or be given other assistance. We are working with this idea in several interdisciplinary areas, combining physics with math, chemistry, and fine arts.

Another new direction is the restructuring of beginning physics courses, with the hope of making these much more flexible from the student point of view. Existing and new dialogs will be employed. The new facilities will involve an interactive course management system, a database on student progress accessible by the student, by the instructor, and by computer dialogs. An evolutionary process over several years is contemplated. We hope that eventually the course can be adapted to the needs and interests of individual students, so that different students can follow different paths through beginning physics. In addition to the problems of software development, two challenging obstacles must be overcome before such a system is practical; the pedagogical problems of keeping students active in a relatively free environment, and the problems of convincing faculty that the resultant course is a desirable alternative to conventional courses.

#### RECOMMENDATIONS

Much additional experience is needed in developing computer-based learning material. As with any new teaching media, initial uses tend to be imitative, and so do not exploit the full capabilities of the media; thus, early computer use often resembled programmed instruction. This fact, that we are still learning, has important implications.

As we do not actually know how to use the computer fully effectively in learning, we must be careful not to rule out any possibilities. This suggests that at least some development work be done on full general-purpose computers, rather than on specialized hardware or software. A specially designed "CAI system" must make decisions which restrict what is possible, but in a full multipurpose system all the computer facilities are available.

A related suggestion is that some development should be discipline-oriented. The experience needed to improve our use of the media may be somewhat different from area to area. Cooperation between groups of institutions should also be encouraged, because such cooperation allows a greater concentration of faculty participation in each discipline.

Several hardware directions seem particularly worth pursuing at the moment. The extremely rapid development of microcomputer technology, and the accompanying decrease in price, suggests that stand-alone systems, each containing the necessary computer power, are a good bet for educational use in the near future; such a system could connect to a larger computer for special purposes, but it would mostly operate alone. Without the restrictions imposed by communication lines, much faster displays with color and dynamic animation would be possible. Reliability could be improved, as failure would affect only one user. In spite of recent work, the combination of other media — audio, slides, video or film sequences — with computer dialogs still leaves much to be desired. It appears that the home videocassette system, such as that being developed by MCA, Phillips, IO-Metrics, and others, offers a good solution to this media problem, and these systems could also be the programming basis of stand-alone systems.

## SELECTED PAPERS AND DOCUMENTS

### Progress Reports:

The Physics Computer Development Project — Alfred Bork and Richard Ballard, Journal of College Science Teaching, Vol. II, No. 4, April, 1973.

The Computer in a Responsive Learning Environment — Let a Thousand Flowers Bloom — Alfred Bork, Dartmouth Conference Proceedings, April 12, 1971.

Computer-Based Mechanics — Alfred M. Bork, Conference on Computers in Science Education (I.I.T., 1970).

Physics Dialogs for Student Use — Alfred M. Bork, September 24, 1973.

### Graphic Dialogs:

Inexpensive Timeshared Graphics on the Sigma 7 — Alfred M. Bork, September 29, 1971.

Computer Graphics and Physics Teaching — Alfred Bork and Richard Ballard, February 25, 1972, Third Conference on Computers in the Undergraduate Curriculum, Atlanta, 1972.

Model Programs — Great Expectations — Richard Ballard, Fourth Conference on Computers in the Undergraduate Curricula, Claremont, California, June 18, 1973.

Exploring New Worlds — Richard Ballard, Proceedings of the 13th Annual Convention of Association for Educational Data Systems, Virginia Beach, Virginia, May 29, 1975.

### APL Graphics:

Graphic APL for the Sigma — Alfred M. Bork, Xerox User Group Proceedings, Vol. 1, December 7-8, 1972.

Ten Finger APL — An Introduction to APL from the Terminal — Alfred M. Bork, September 11, 1974.

APL as a Language for Interactive Graphics — Alfred M. Bork, January 22, 1974.

### Nongraphic Dialogs:

A Computer-Based Dialogue for Deriving Energy Conservation for Motion in One Dimension — Alfred Bork and Noah Sherman, American Journal of Physics, Vol. 39, 137-143, 1971.

Computer Assistance in Student Problem Assignments — Mark Monroe, June, 1971. Second Conference on Computers in the Undergraduate Curriculum, Dartmouth College.

An Interactive Computer Teaching Dialog for Solving a System of Coupled Oscillators — Charles P. Munch, February, 1972.

A Computer Simulation for the Study of Waves — Alfred M. Bork and John Robson, American Journal of Physics, Vol. 40, 1288, September, 1972.

## Dialog Software:

Teaching Conversations with the Xerox Sigma 7: System Description — Alfred Bork and Charles Mossmann, May 26, 1971.

System Users Manual, UTS Version — Charles Mossmann, Alfred Bork and Dobree Purdy, August 2, 1973.

Graphic Dialog Facilities — Alfred Bork, Estelle Warner, and John Collins, April 17, 1973.

System Maintenance Manual — Dobree Purdy and Alfred M. Bork, August 9, 1973.

Using PCDP Graphic Software at Irvine — Alfred Bork, December 19, 1973.

Using PCDP Materials Away from Irvine — Alfred Bork, August 30, 1972.

The Computer in Learning — Advice to Dialog Writers — Alfred M. Bork, Journal of Educational Data Processing, Vol. 9, No. 3, 1972.

FORTTRAN Graphics — Terry Moore and Alfred Bork, May 14, 1973.

Dialog X — Richard Ballard, November, 1974.

## Computers and Teaching:

Computers in the Physics Curriculum — Ronald Blum and Alfred M. Bork, American Journal of Physics, Vol. 38, No. 8, 959-970, August, 1970.

Science, Education and the Future — Alfred M. Bork, September, 1971.

Computer Needs for Teaching Physics — Alfred M. Bork and Herbert Peckham, April, 1975.

The Computer in Physics Instruction — An Example from Today and Suggestions for the Future — Alfred M. Bork, New Trends in Physics Teaching, Vol. II, Paris, UNESCO, 1972.

Effective Computer Use in Physics Education — Alfred M. Bork, American Journal Physics, Vol. 43, No. 1, January, 1975.

The Computer in Teaching — Ten Widely Believed Myths — Alfred Bork, ACM SIGCUE Bulletin, Vol. 7, No. 4, October, 1973. Reprinted in Points Northwest, No. 6, January, 1974 (American Society for Information Science); EDU No. 11, Spring, 1973.

The Computer in Learning — The Ordinary Mortal — Alfred Bork, National Computer Conference, 1973.

Limitations of APL as a Language for Student-Computer Dialogs — Alfred Bork, September 4, 1974.

## Terminals:

Terminals for Education — Alfred M. Bork, EDUCOM Bulletin, Vol. 7, No. 4, Winter, 1972. (Please turn to page 17, bottom right.)

# Invitation: Science/Technology Exhibition

This is an open invitation to all computer artists to send slides, photographs and descriptions of new computer art for the above exhibition. It is tentatively titled THE VARIED COMPUTER ARTS. It will begin touring the Science and Technology Museums of this country approximately in February of 1977.

Works particularly sought are dimensional, non-flat presentations. Computer art in all styles and forms will be considered. The emphasis is on variety of expression and final presentation. Please see page 5, Section VII: FINAL FORMS OF VARIED PRESENTATIONS OF COMPUTER ART in the August (Art) Issue of Computers and People for suggestions as to final forms. No works on white industrial paper will be considered. However, photographic reversals of these works, as well as transparent sheet film versions of industrial paper works are acceptable. In other words, in this very new exhibition, computer art should be developed on art papers, or work should be taken into other art media.

## BACKGROUND

The exhibition, "Cybernetic Serendipity" marked the emergence of a new art form: experiments in the computer and the arts. This landmark exhibition will remain as an important "first" in the history of computer art.

However, great changes are occurring in the computer arts: varieties of final forms reveal computer designs in films, editions of lithographs, etchings, serigraphs, and stamps designed by the computer. Textiles are not only being woven but screen-printed with computer designs. Sculpture and paintings designed by the computer (and man) afford new dimensions in the computer arts. Television programs combine many forms of art: lasers, music, graphics, and dance.

## DEADLINE FOR RECEIPT OF DESCRIPTIVE MATERIALS

The deadline for receipt of slides, photographs and descriptive material about the work is due in Chico on October 15, 1976. Please send these materials to:

Grace C. Hertlein, Editor  
COMPUTER GRAPHICS & ART  
Berkeley Enterprises, Inc. - Chico Branch  
555 Vallombrosa, #35  
Chico, California 95926

Notification of selections for the new exhibition will be sent out on November 1, 1976. Works accepted for the Science and Technology Exhibition are due in Chico by December 20. For a Xerox copy of the participating museums, send a request to the Editor.

Coupon for Ordering the INTERDISCIPLINARY GRAPHICS BIBLIOGRAPHY and the FORTRAN IV ART MANUAL:

The long-awaited 55 page Interdisciplinary Graphics Bibliography and the 77 page FORTRAN IV ART MANUAL are now available at very low cost.

Supplies are limited, so order yours quickly! They were printed at cost by the Chancellor's Office of the California State University & Colleges.

Note: The ART MANUAL is meant for Intermediate Programmers — although suggestions are given for use by beginners and advanced users. Since the report was completed (June 1, 1975), new research has been accomplished in the areas of beginners' programming techniques (a new system) and advanced users. This material will be published sometime in early 1977.

Enclosed is my CHECK for:

- \_\_\_ \$ .53 - INTERDISCIPLINARY GRAPHICS BIBLIOGRAPHY  
(50¢ cost plus 3¢ Calif. Sales Tax)
- \_\_\_ \$ .64 - FORTRAN IV ART MANUAL  
(60¢ cost plus 4¢ Calif. Sales Tax)
- \_\_\_ \$ 1.17 - FOR BOTH REPORTS

TO: Cynthia Allen  
DOCUMENTS DIVISION  
Office of the Chancellor  
California State University & Colleges  
400 Golden Shore  
Long Beach, California 90802

Postage will be paid by the Chancellor's Office.

COUPON FOR ORDERING ART REPRODUCTIONS —  
FOR SUBSCRIBERS ONLY — BONUS

\_\_\_ Please send me \_\_\_ set(s) of three Hertlein computer art reproductions as advertised in the May, 1976 issue of CG&A. I enclose \$2.50 for each set of three prints. (This includes tax and postage.) Please make checks payable to Berkeley Enterprises, Inc.

TO: COMPUTER GRAPHICS AND ART  
Berkeley Enterprises - Chico Branch  
555 Vallombrosa, #35  
Chico, California 95926

NAME \_\_\_\_\_ ORGANIZATION \_\_\_\_\_  
ADDRESS \_\_\_\_\_  
CITY \_\_\_\_\_ STATE \_\_\_\_\_ ZIP CODE \_\_\_\_\_

REFERENCES (Concluded from page 16)— Al Bork

## Sigma 7:

An Informal Introduction to the UCI Sigma 7,  
Alfred M. Bork, September, 1974.

## Miscellaneous:

George Leonard's View of the Computer in Education — Alfred Bork, Creative Computing,  
November-December, 1974.

Learning, Computers, Pictures — Alfred Bork,  
The Journal, Vol. 1, No. 5, pp. 6-13, November, 1974.

Learning with Computers — Today and Tomorrow  
— Alfred Bork, January, 1975.

# Computer Graphics and High School Education

by Dr. Kai Chu  
Mt. Diablo High School  
2450 Grant St.  
Concord, Ca. 94520

"After going through the usual (traditional) training in FORTRAN, I found that they were not learning. In fact, their original enthusiasm had disappeared...The use of the computer as a design tool in the applied arts might just be the thing that would turn her on (and other students) to learning about computers and programming."

## COMPUTER GRAPHICS AND SELF-AWARENESS

In this article, I would like to share with you some of my experiences as a high school teacher for the past three years in the Mt. Diablo High School District in Concord, California. These experiences in computer graphics have been very meaningful and rewarding to me and to my students. They fall into two areas:

1. The basic level of computer information, acquisition and skill development in programming attained via computer graphics, and
2. A higher level of sensitivity and awareness attained by students.

## TRADITIONAL TEACHING OF PROGRAMMING

Today the use of a computer is no longer a luxury. Therefore, some understanding of it is desirable to avoid unnecessary fears, due to ignorance of this machine.

With the acquisition of computers for administrative programming, more high schools are beginning to teach programming. Some educators feel that the high school is the "ideal" time to introduce programming and computer concepts.

Generally, the traditional way of teaching programming is through solving complicated mathematical problems. The necessity of having a strong

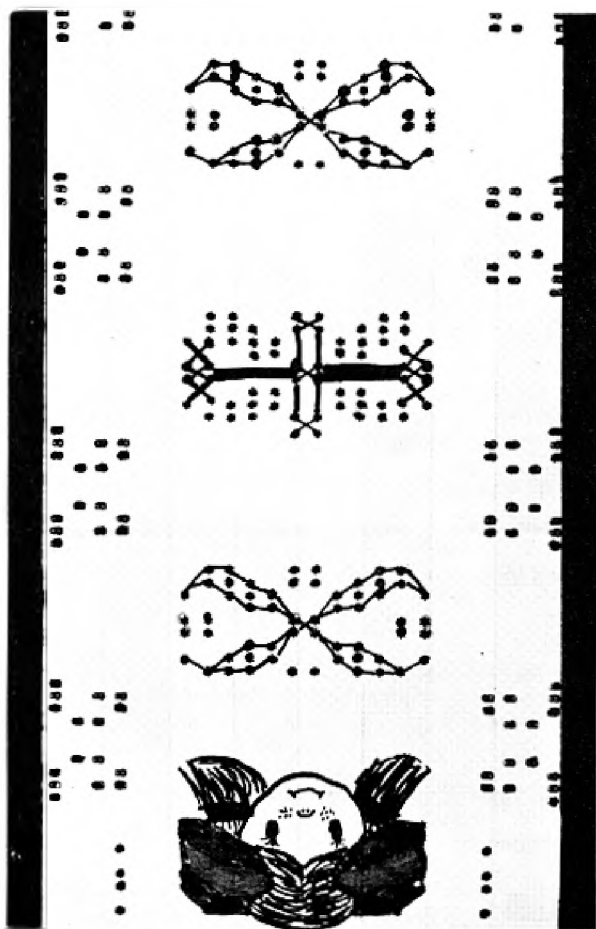

ABOVE: Textile design by Julie Moeller, Mt. Diablo High School.

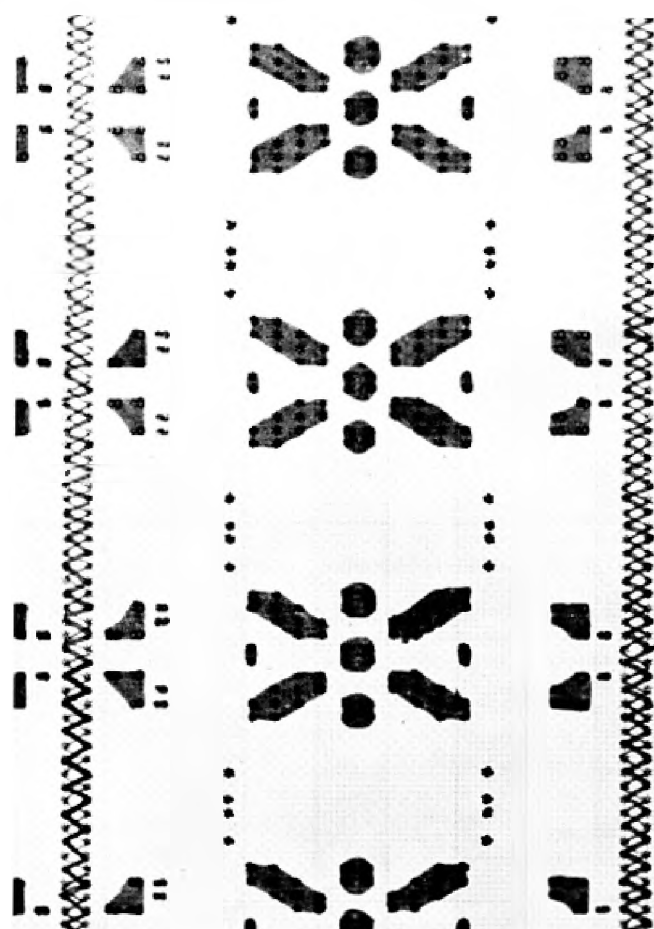

ABOVE: Sherri Price explores three designs for textiles.

mathematics background limits the type of students who can participate in such a program to the elite few.

In order to broaden the base of participants to encompass more than this top mathematics and science group, a new approach is mandatory. Computer graphics appears to be the ideal vehicle for imparting a successful computer experience to more students.

#### THE FIRST CLASS OF DATA PROCESSING STUDENTS

Three years ago a small group of Business Education students signed up for my class in Data Processing, and wanted to learn about the use of computers.

After going through the usual (traditional) training in FORTRAN programming, I found that they were not learning. In fact, their original enthusiasm had disappeared. For them, there simply was no fun in learning, since both the mathematics problems and the FORTRAN programming were too abstract to relate to their world.

Thus I was faced with a problem: my course of instruction could not meet the needs of these students. In order to solve this problem, I scheduled private talks to jointly explore (with students), possible new areas of interest.

I asked, "What would you like to do?" The response was typically, "I don't know..." accompanied by a shrug of the shoulders. I questioned further, "Suppose you were out of school now, and you needed to find a job. What kind of job would you pick?" A typical response was the following: "I don't know...Oh, maybe a salesgirl at Macy's, or a secretary in a business office." In her voice, I detected a lack of enthusiasm. I was not getting anywhere.

But I knew there must be a solution to introducing computers and programming in a meaningful, enjoyable way. I persisted, "Now let's suppose that you were given all the money needed, and all the opportunities you desired. What would you do?"

I could see her eyes open widely. Her attitude completely changed. Her imagination was now challenged. Then with a beaming smile, she said, "You know, I really think that I have a knack with dressmaking. I know just what fabrics and patterns to pick, and which style fits a person. Someday I'd like to open up a boutique shop. I'd love to do that!"

#### A NEW IDEA: A FABRIC DESIGN SYSTEM

The key words I heard were "fabrics" and "patterns". The repetitiveness of a textile pattern seemed to be something that a computer could do, and do well. The visual aspects of a dress pattern could strongly enhance this student's understanding of computer programming. It is always easier to do something if one knows in advance what the results should be. Programming and debugging of a program could become more understandable for this student when she could see what was wrong with the physical shapes of a pattern.

The use of the computer as a design tool in the applied arts might just be the thing that would turn her on (and other students) to learning about computers and programming.

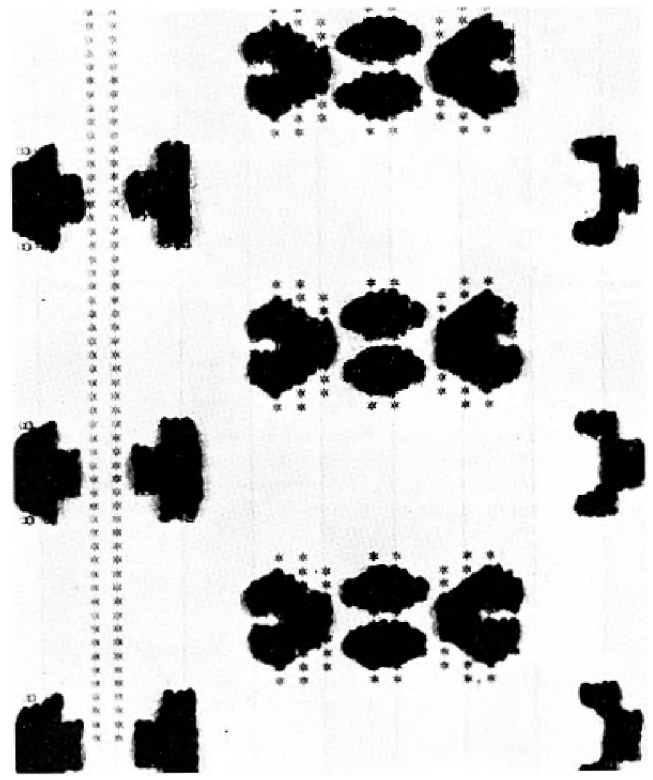

ABOVE: Design for stitchery by Lynn Richards, Mt. Diablo High School.

I became enthusiastic about the prospect, and asked, "Would you be interested in doing fabric design with computers?" I added, "You can create your own patterns." She replied, "Yes, that would be exciting! But how?"

I had heard of using X/Y plotters for computer graphics, and recalled the work of Professor Grace Hertlein and her students at California State University, Chico. But my search for new equipment was not successful, and the response for new funds was disappointing. Nevertheless, I had the feeling there must be a solution.

In the meantime, I wondered (and dreamt), what would I do if I had all the financial support needed for such a system? I would design a multicolor fabric machine attached to (or interfaced) to a micro-processor, with a video monitor for viewing the color patterns being designed. When a fabric design was finalized, then with a push of a button, the machine could produce yards and yards of fabric. As an electrical engineer, and a person who had patented some inventions, the dream machine appeared feasible.

But I did not have such a machine. Suddenly, I realized that my old line printer might be modified to simulate such a machine, for it generates yards and yards of computer paper! The computer paper is wide enough to lay out dress patterns and would perhaps be even better than a plotter for our purposes. We could also manually simulate the color aspects of the machine to some extent.



## IMPLEMENTATION OF THE FABRIC DESIGN SYSTEM

My next job was to map out the logistics of implementation, using what we had. We were limited by three major constraints:

1. The choice of the programming language,
2. The availability of the computing system, and
3. The capabilities and backgrounds of my students.

Regarding a programming language, ideally we needed a relatively sophisticated language for manipulating character strings. FORTRAN and APL were available on our system.

Considering points two and three, I decided to use FORTRAN, because this was the language the students were presently studying. In addition, I had discovered some system-available FORTRAN packages that could be used for character string manipulation. The use of the traditionally labeled "scientific programming language" for other (art) purposes would be an eye-opener for the students.

Along with the above-mentioned FORTRAN packages, I would need to write a minimum number of subprograms and subroutines for the smooth functioning of the FABRIC DESIGN PROGRAM, rendering an optimum system for computerized fabric design.

### USING THE SYSTEM

For teaching purposes, the FABRIC DESIGN PROGRAM is system analyzed into a set of subprograms and subroutines, which are then parcelled out to the students for implementation.

The design procedures make frequent use of calling techniques to make system implementation (or use) easier. The computing system used at our high school is an IBM 1130. The console typewriter served as input to accomplish the experimental pattern design, and the line printer for display of the overall perspectives of the design.

Further, our FABRIC DESIGN SYSTEM allowed the designer to erase, modify, or add new elements to the existing design, so that the artist could feel as comfortable with the computer as if it were a drawing board. Later a conversational mode was implemented, with computer-aided instructions to allow the designer to communicate with the computer in English, thereby avoiding the need to learn a programming language. Students had a choice in the method of use of the FABRIC DESIGN SYSTEM.

There were other design factors to be considered, such as color, texture, etc. But for the present, I decided to solve this aspect by having the students apply colors manually to the computerized printouts. Thus we could test to see if the computerized fabric design could help save time and energy for the designer. Some of the key questions were: Does the basic structure of pattern printout system tend to limit the creativity of the designer, or enhance it? Can computerized fabric design really be a useful tool for the designer, so that the artist is free to do more creative work?



## STUDENT RESPONSES TO THE SYSTEM

The results were overwhelmingly positive! In fact, the success of the system was far beyond my expectations. On the average, most student designs took three to four class periods to complete, i.e., from inception of an idea to the finished design. This was a relatively short period, considering that the students were in the tenth and eleventh grades, and most of them had no previous design experience.

Some students thought that they could never do an art design, and they were surprised at their pleasing results. They were encouraged by each other's work. Some final designs were so colorful and vivid that their beauty exceeded what we might have expected in the printout phase of this project.

Repeatedly the students found that the use of the computer as a design tool does not in any way hamper the creativity of the designer. In fact, it enhances the artistic process. Students who would not "dream" that they could create such works found that they could do so with the aid of the computer. The computer helps them to do things that they often cannot do manually.

An example is a design by Bitsy Behrendt, below. (The reader will have to imagine the colors, since the illustrations are in black and white for budgetary purposes.) Here are color comments:

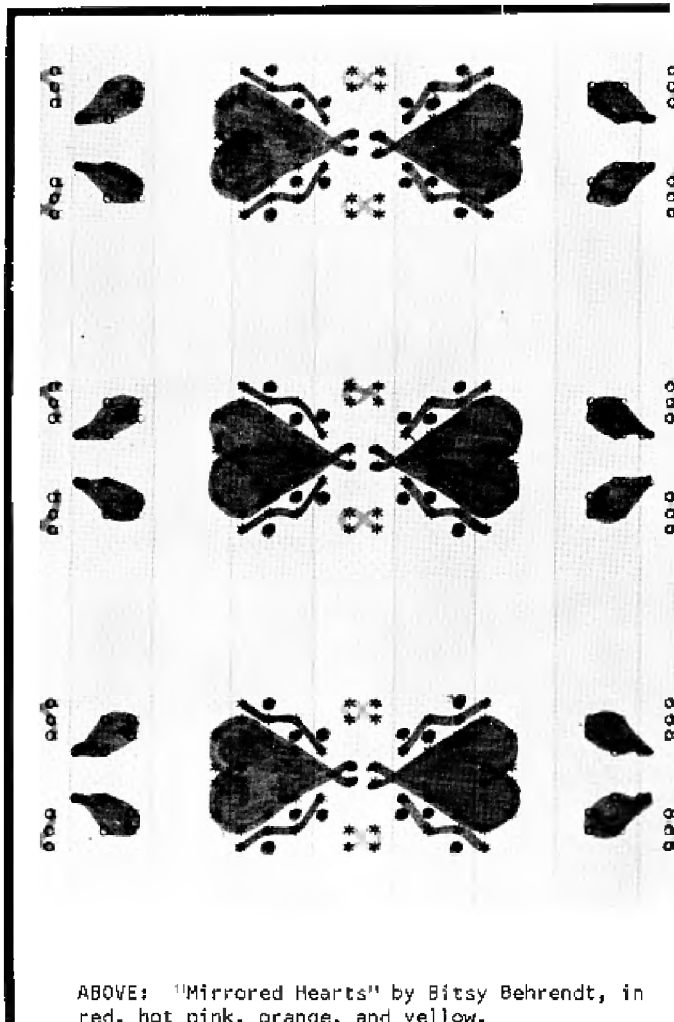

ABOVE: "Mirrored Hearts" by Bitsy Behrendt, in red, hot pink, orange, and yellow.

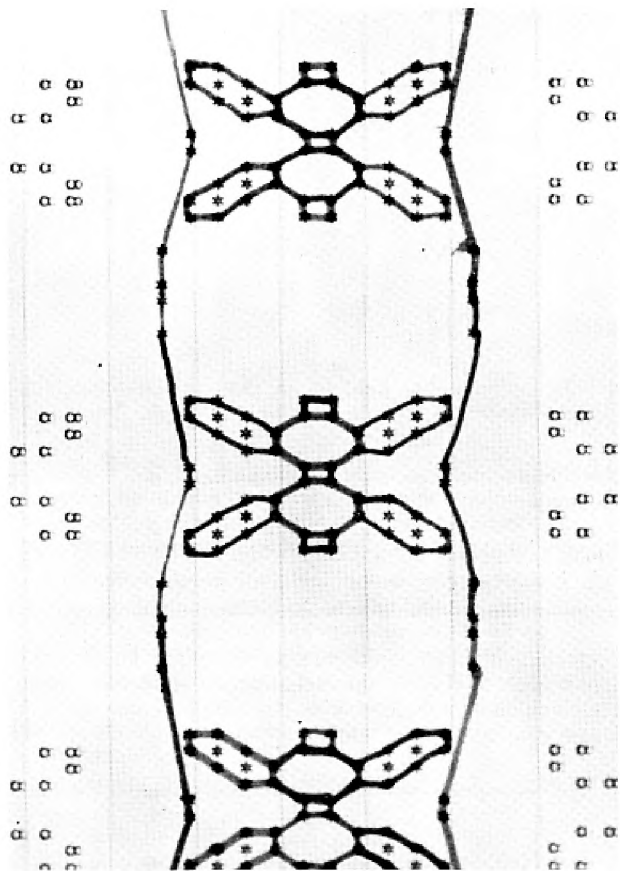

ABOVE: Pattern design by Alice Martinez, from Kai Chu's class in Data Processing.

Bitsy chose a red color (pinkish in hue) for the top row of hearts, and placed several dots of the same color on both sides of the heart to lend support to the pattern. The dots created a dispersion effect. The "wiggled designs" in a warm orange seemed to wander in and out of the dotted configuration, forming the top half of the major pattern of her design. This trio is then horizontally mirrored to provide a sense of symmetry, but with an interchange of colors (the mirrored hearts and dots in orange instead of red, and the wiggly lines in red). The partial "figure-8" is executed in a yellow, bringing the two halves of the design into an integrated major pattern. A second, or minor pattern, is composed of "tear drops" and "X-like" figures. The left tear drop is orange, and the right one, pinkish-red. The X-like patterns are in yellow. Again, the patterns are mirrored, so that a continuous design for textile is achieved.

In the above illustration, Alice Martinez makes use of only a portion of the design printout, as in a border print.

The kinds of designs varied with each group, and the results were unexpected. The diversity of designs was almost unlimited. (For more patterns, see the August Art issue of *Computers and People*, page 24 for works by Sharon Lauthner and Bitsy Beherndt.)



## SUMMARY

To summarize the experiences in computer graphics, as an outcome of the FABRIC DESIGN SYSTEM, the students experienced a tremendous sense of pride and satisfaction, because they participated in a new project in which they could become involved, rather than solving textbook problems they could not relate to, and could not get excited about. There was much greater learning, faster learning, and there were more incentives to learn. (See the next section on methods of presentation.) All the students could relate to graphics in some form, and they could quickly achieve a level of satisfying creativity. Computer graphics proved to be a painless way to introduce programming, and to proceed to complex concepts and problems that we could not present in the traditional manner. Further, the amount of work they produced was remarkable.

## MY PHILOSOPHY OF TEACHING

Earlier I mentioned a higher level of sensitivity and awareness attained by the students. My teaching experiences have convinced me that quality education comes from individualized attention to students' interests, and from a curriculum that meets their varied talents and needs. When taught in such a way, the student can develop and grow at his or her own pace, and at the highest level of capability. The students need to become involved in what they are doing, and to have a feeling of success.

Computer graphics is ideal for such purposes, because of the diversity of topics in which graphics may be used: business, mathematics, physical and natural sciences, art, etc.

In addition to using computer graphics as a tool for teaching programming, I used a new approach in teaching methods.

## THE HIERARCHICAL TEACHING METHOD

I have devised a method called a "hierarchical teaching method" for individualized learning. For a given topic, I would begin by teaching only one or two students who expressed curiosity or interest (thus providing the initial motivation). After making sure that the material was thoroughly learned, I would then announce to the class that this particular student was now a "teacher" for this topic. Any of the other students interested in this topic should go to him or her for instruction. The pride in being recognized as a "teacher" was a tremendous reward, and such a reward was immediate. Those who taught received extra credit.

Teaching provides another opportunity for the student teacher to review and more fully understand what has been learned, in order to teach it to others. Often I found that some of the shy students learned more quickly and better from their peers, because of the natural positive rapport that exists between them as friends and equals. On my part, I made a point of teaching every student first-hand, on a rotational basis.

## ELIMINATION OF COMPETITION

However, the hierarchical teaching method would not have succeeded without first discarding the unhealthy aspects of competitiveness in the traditional grading system. Many students today are isolated or alienated. They are afraid that the

act of helping others may be detrimental to their own grade. I make an effort to know students on an individual basis, so that I may fathom the potential and the interests of each one, and monitor their progress.

Grades are based on each student's efforts and rate of progress, so that each student has an equal opportunity to excel. Only in this way can they become free enough to help others, and at the same time benefit themselves. This not only removes the unhealthy tensions among students, but also opens up an atmosphere of friendliness and mutual concern, which is the prerequisite for a meaningful community. In fact, we consider our classroom to be a small community of our own, where we live in the present, and enjoy every moment we spend together.

SUMMARY

The joy of learning should be more important than simply getting facts and information. Creative learning is a continuous process to probe life, to search for its meaning, and to live in happiness.

It is an ongoing process, is it not? A particular subject matter is merely the vehicle to carry on the process of learning zestfully, together. Computer graphics can be one such vehicle.

**EDITOR'S NOTES:** Dr. Kai Chu is an atypical high school teacher: he chose to teach high school, after working professionally in industry as an electrical engineer, and after university teaching, both here and abroad. His philosophy of teaching is idealistic -- and effective.

Recently we spent a long afternoon talking about computers and creative teaching, while I visited Kai Chu in his Berkeley home, perched among the high hills overlooking San Francisco and the Golden Gate Bridge.

I asked him why he chose high school teaching, and if he found this satisfactory with his technical background as an engineer. He related his experiences in industry, and in university teaching, and remarked that he had kept searching for "something else" -- something that might be more meaningful. After much thought, he decided that teaching young people about computers might be that avenue of usefulness.

For the past three years Kai Chu has spent his time in varied tasks for the Mt. Diablo High School District, performing many tasks, rather than one assignment. His recent simultaneous work involves administration, planning and research work; teaching teachers, and teaching high school students. He is now on academic leave for two years.

At the present writing, Kai Chu is making a new journey to Bombay, India, where he will spend the next two years studying Ved and practicing Vedanta. I asked him, "Are you not worried that all this philosophy will unfit you for practical work when you return? Is it illumination per se that you are seeking?" He replied with a quiet smile, Oh no -- illumination is to light your life, so you can do practical things in a very real world. It is light put to use in life. I will return from India, and do more useful things with computers and people."

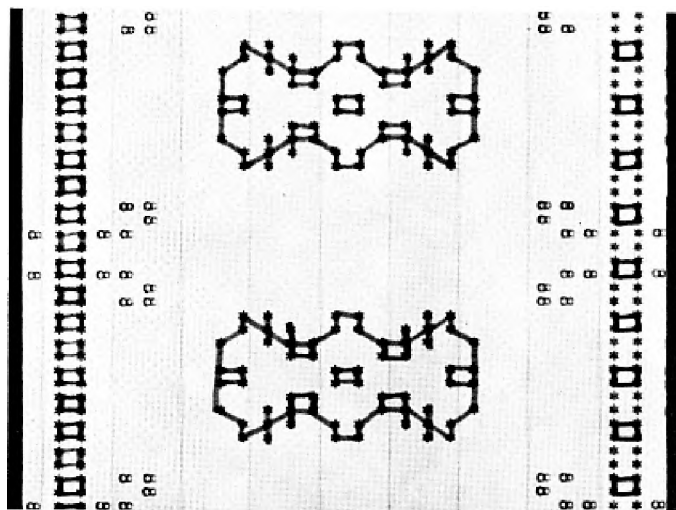

ABOVE: Detail of a textile design by Sherri Price.

BELOW: A complex pattern by Harjnder Rajasansi. Although the work has not been colored in, it offers many possibilities for development, since the pattern is more dense than many of the others.

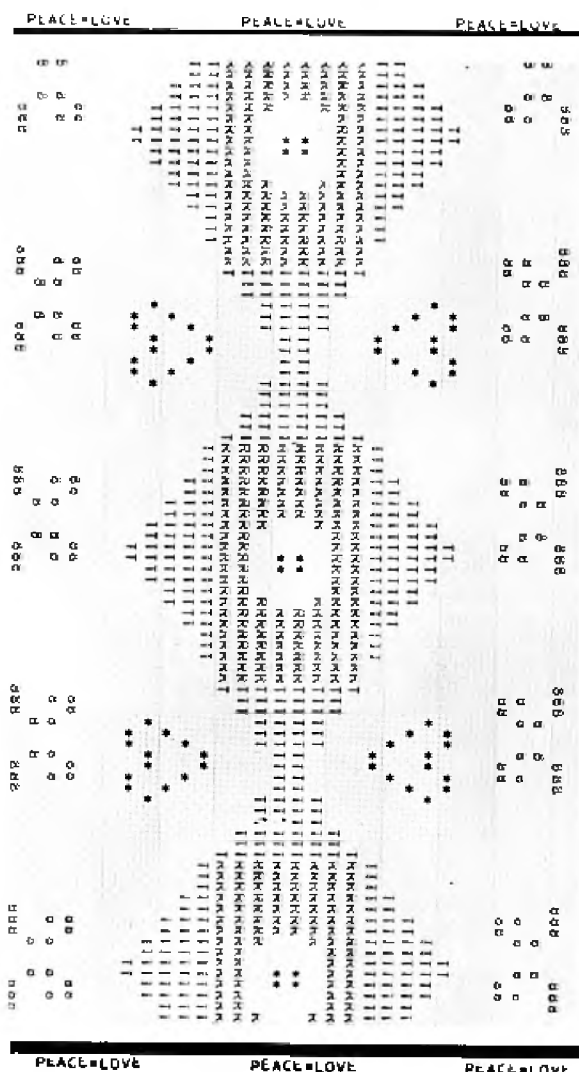

# COMPUTER GRAPHICS AND ART

FIRST TWO ISSUES NOW PUBLISHED



## Partial Table of Contents — Vol. 1, Nos. 1 and 2

### Learning Through Graphics

by Dr. Al Bork, University of California, Irvine, California  
A ten-year forecast for computers, education, and graphics by a leading authority.

### Art of the Technical World

by Dr. Herbert Franks, Munich, Germany  
Computer art as the bridge between the two realms of art and leisure.

### Expanding the Graphics Compatibility System to Three Dimensions

by Richard F. Puk, Purdue University, Lafayette, Indiana  
Design considerations for a user-oriented 3-D graphics system.

### A Personal Philosophy of Ideas, New Hardware, and the Results

by Duane Palyka, University of Utah, Salt Lake City, Utah  
The frame-buffer from Evans and Sutherland allows the artist to treat the computer as a paint and brush medium.

### How to Build Fuzzy Visual Symbols

by Alex Makarovitch, Honeywell Bull, Paris, France  
A new approach to computer art and graphics by a computer scientist.

### The State of the Art of Computer Art

by Grace C. Hertlein, Editor  
Comparisons of early computer art and today's newer art. What is art? What is art in computer art?

### Inexpensive Graphics from a Storage Cathode Ray Tube

by Charles J. Fritchie and Robert H. Morriss, Tulane University, New Orleans, Louisiana  
Illustrations and photographic techniques used to achieve graphics from a storage tube CRT.

### An Investigation of Criteria for Evaluating Computer Art

by Thomas E. Linehan, Ohio State University, Columbus, Ohio  
The new aesthetic of computer art requires a departure from the previous, formalist-traditionalist doctrines for evaluating art.



*COMPUTER GRAPHICS and ART* is a new international quarterly of interdisciplinary graphics for graphics people and computer artists. This new periodical is aimed at students, teachers, people from undergraduate and graduate institutions, researchers, and individuals working professionally in graphics. Its topical coverage is broad, embracing a variety of fields. It is useful, informative, entertaining, and current. Our goal is excellence, and to achieve this objective, we invite our readers to participate actively in the magazine, and to advance the state of the art of computer graphics by communication, sharing, and dissemination of ideas.

We invite you, your colleagues and students to help us achieve this goal.

## List of Coverage for Up-Coming Issues

- Applied Arts and Graphics
- Architectural Graphics
- Cartography Systems
- Computer-Aided Design
- Computer Assisted and Managed Instruction
  - Utilizing Computer Graphics
- Computer Graphics in Physics, Chemistry, Mathematics, etc.
- Computer Programs for New Applications
- Display Systems and Graphics
- Fine Art and Media Explorations
- Graphics in Business
- Hardware Systems and Graphics
- Interactive Graphics Languages and Systems
- Languages for Computer Graphics and Graphics Primitives
- Software Systems and Graphic Requirements
- Statistical Packages and General Graphing
- Syllabi for Computer Graphic Courses

----- (may be copied on any piece of paper) -----

To: *COMPUTER GRAPHICS and ART*

Berkeley Enterprises, Inc.  
815 Washington St.  
Newtonville, Mass. 02160

- Please enter my PERSONAL (U.S. and Canada) subscription to CG&A (\$10 per year).
- Please enter my FOREIGN PERSONAL subscription to CG&A (\$13 per year).
- Please enter my LIBRARY/DEPARTMENTAL subscription to CG&A (\$15 per year).
- Enclosed is my PERSONAL CHECK AND/OR PURCHASE ORDER for CG&A.
- Enclosed is \$2.50 for a sample copy of CG&A (applicable toward a subscription).

FULL REFUND IN 30 DAYS IF NOT SATISFACTORY

Name \_\_\_\_\_  
Title \_\_\_\_\_  
Organization \_\_\_\_\_  
Address \_\_\_\_\_

HERE IS YOUR OPPORTUNITY FOR FEEDBACK TO US:

- I hope to submit for publication in CG&A material on the following topics: \_\_\_\_\_
- I am interested in reading materials by the following authors: \_\_\_\_\_
- I am particularly interested in coverage of the following subjects: \_\_\_\_\_
- I would like to receive materials on other Berkeley Enterprises, Inc. publications:  *COMPUTERS and PEOPLE*  *The COMPUTER DIRECTORY and BUYER'S GUIDE*  *People and the PURSUIT of Truth*  *The Notebook on COMMON SENSE and WISDOM*  *WHO'S WHO in COMPUTERS and DATA PROCESSING*  Books
- I am interested in:  black and white computer art reprints at low cost (a bonus for subscribing to CG&A)  77 page FORTRAN IV art manual  45 page interdisciplinary graphics bibliography by G. Hertlein
- Additional Comments (attach another paper if needed): \_\_\_\_\_

# Graphics Applications: Paintings

by Roger Coqart  
Avenue A. Depage 29/1  
B1050 - Bruxelles, Belgium

"In such an approach (geometric patterns and combinations), the highest degree of objectivity is called for, and the next inevitable step is the use of the computer."

## NOTES FROM BELGIUM

First of all, I am not a computer magician. I probably never will become one in the future. I learn step by step the different techniques I wish to use, those which are indispensable in my work.

I do not use the computer for the sake of using a sophisticated gadget, nor out of artistic snobishness — but because I'm sincerely convinced that artists who exploit geometric patterns and combinations, as I do, should absolutely ban the subjective factor which is unnecessary and encumbering. The latter methods cause embarrassing intuitive repetitions and fail to show a convincing picture of the possible (potential) arrangements and/or configurations of the given geometric elements.

In such an approach, the highest degree of objectivity is called for, and the next inevitable

step is the use of the computer. However, I do not think I have to convince you (and others) of this.

In my case, it all began three years ago when I first used a computer in my search for objectivity in graphic presentation. I began with a systematic study of a random distribution of a fixed number of small squares inside a larger square. I found this so fascinating, that at this moment — after three years — I'm still concerned with the square, as you can see by the accompanying examples.

Everything in computer art reminds me of photography with which I have been concerned for more than 15 years. From the development of a basic idea, to the reactions of the public, everything is an endless repetition.

We may be grateful, in computer art, to have the opportunity of exploring an unmolested world.

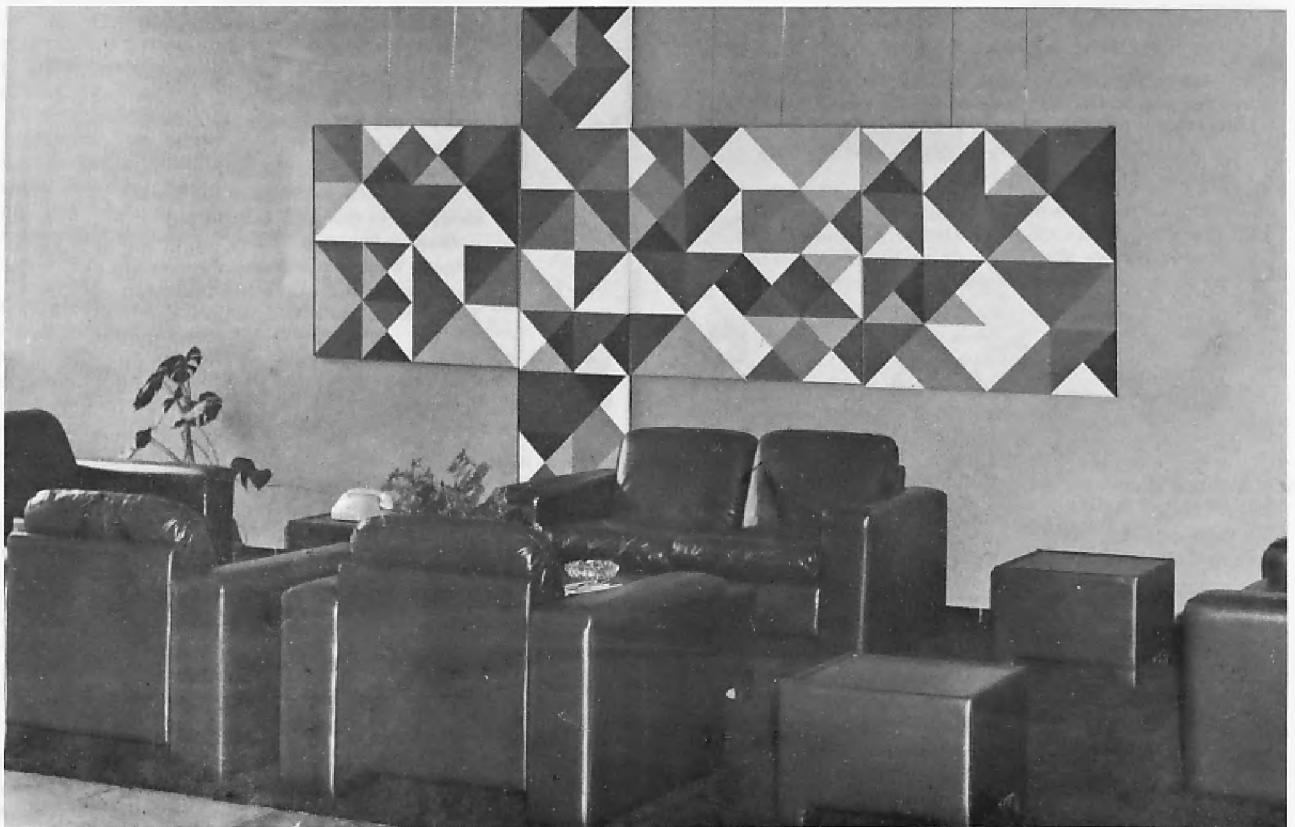

ABOVE: Color "Permutable" Series, 200 X 350 cm. — 16 permutable panels, each 50 x 50 cm. Paint on resin-coated wood, executed in 1975. Panels are interchangeable. See the drawing, "Traveling through the Square Series", computer drawing, 64 x 64 cm., 1976.

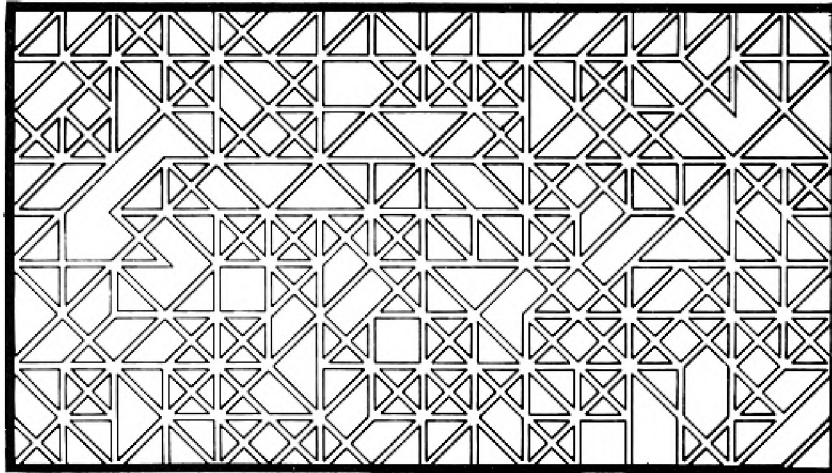

ABOVE: Detail (or portion) of the drawing "Traveling through the Square Series", 64 X 64 cm., 1976.

BELOW: "Structured Square Series — Inwards", drawing 28 X 28 cm. Other words in the series are "Horizontal Rows", "Outwards", as well as the "Permutation" works.

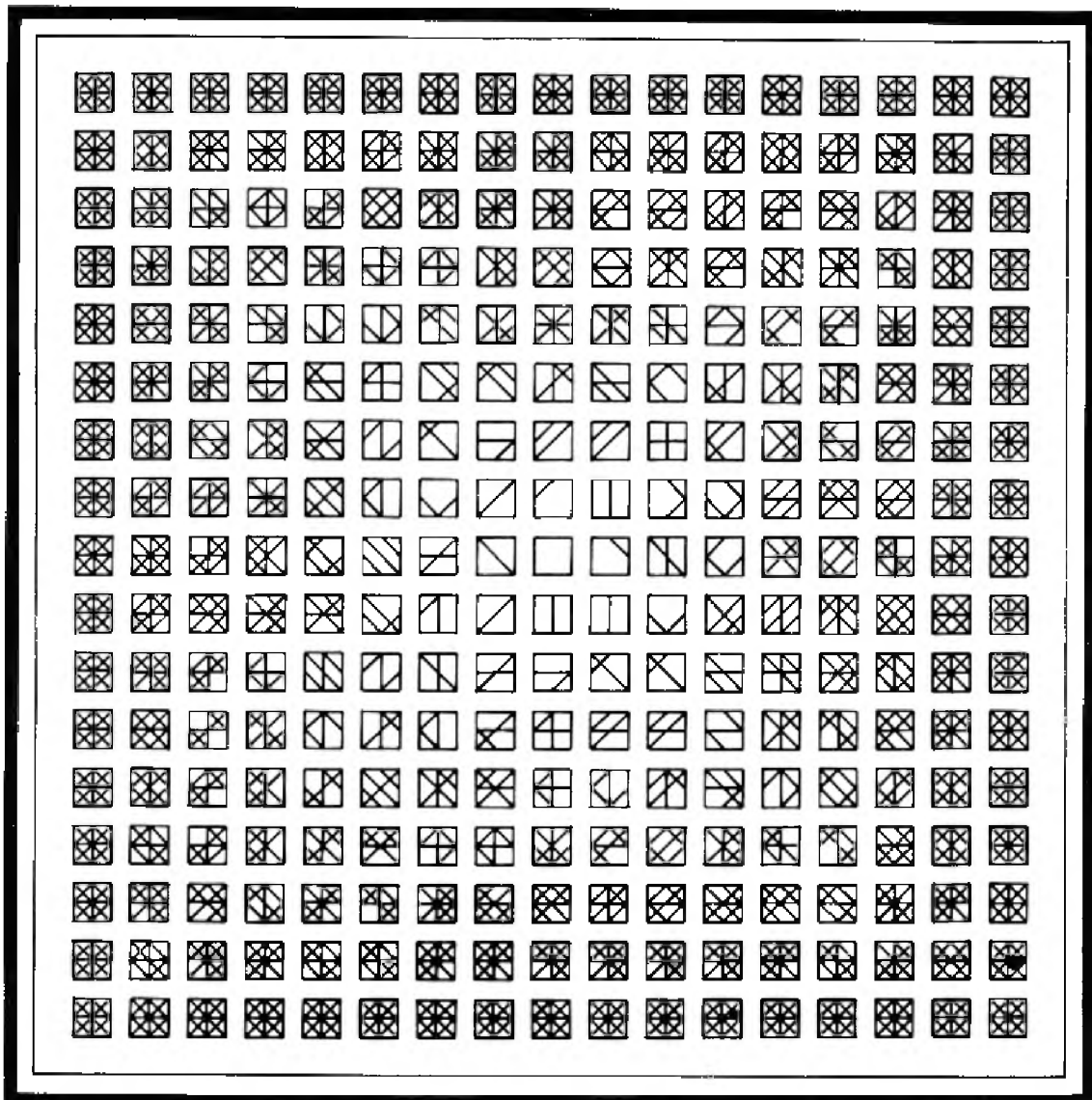

# AN ART CHAIRMAN'S FLASHBACKS

by Jackie Potts  
Social Security Administration  
3D 21 Operations  
Department of Health, Education & Welfare  
Baltimore, Maryland 21235

Have you ever wondered what takes place behind the scenes of the NCC Art Exhibitions, the planning, the frustrations, and the innumerable tasks to be accomplished and coordinated by a chairman and committee members? Here is a personal account of the NCC Art Exhibition by Arts Chairman, Jackie Potts.

## FLASHBACK

His excellency, George Bechard, the Canadian Consul General to the United Nations, had just begun speaking. Minutes earlier we had opened the first major special activity of the 1976 National Computer Conference (NCC), the Computer Art Exhibit, by introducing Dr. Carl Hammer, the Conference Chairman.

The scene was the Rhinelander Galleries of the New York Hilton at 4:00 P.M., Sunday, June 6.

My mind suddenly traveled like a drowning person to all the events leading up to this moment.

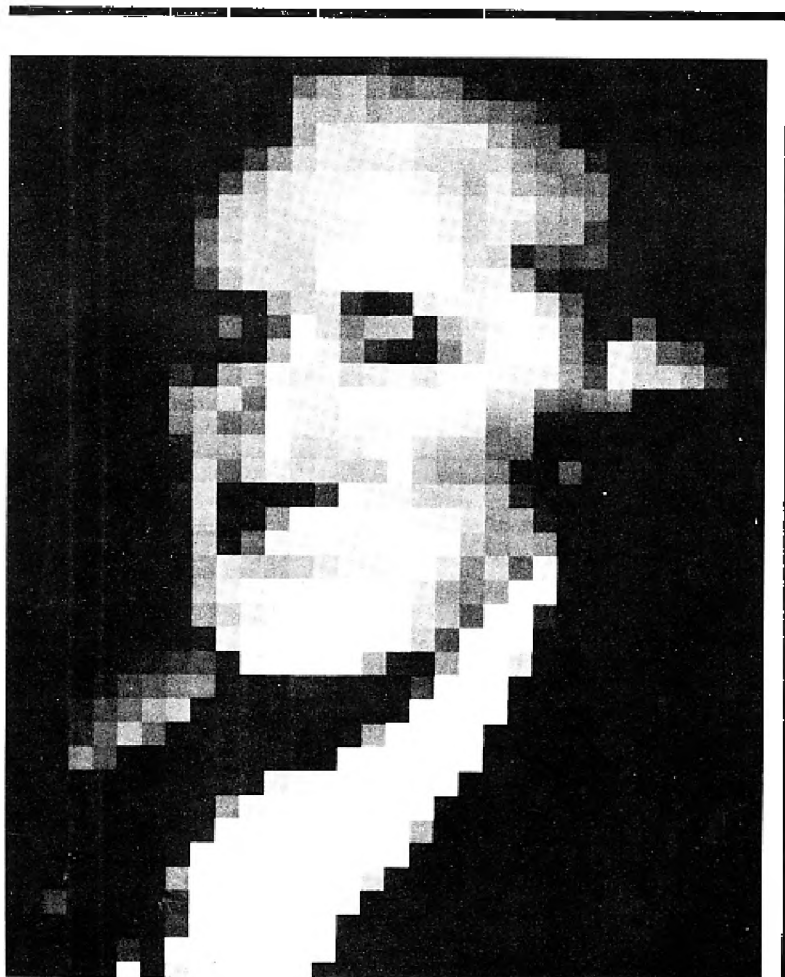

ABOVE: "George Washington" by E. T. Manning, 7 feet X 9 feet.

## BACKGROUND

In February Dr. Carl Hammer had written the Social Security Administration, requesting that I serve on the Steering Committee of the '76 NCC, with the Chairmanship of the Computer Art Exhibition as my special assignment.

Even while waiting for approval, I started the search for a committee, wanting to have representatives from every part of the United States and from various disciplines. The first three official appointments were William Fetter, Southern Illinois University, Carbondale, Illinois; Alyce Branum, Digital Equipment Company, Maynard, Massachusetts; and Kenneth Knowlton, Bell Laboratories, Murray Hill, New Jersey. The committee was soon augmented to include: Kurt Lauckner, a past NCC Art Chairman, Eastern Michigan University, Ypsilanti, Michigan; Grace Hertlein, another past NCC Art Chairman, California State University, Chico, California; E. T. Manning, Watson-Manning, Stratford, Connecticut; George Kouhoukos, Government Employees Insurance Company (GEICO); William LaPlante, AFData Services Center, Bethesda, Maryland; and Dr. Jean Bevis, Georgia State University, Atlanta.

Due to unavoidable delays, I did not join the once a month all-day meetings of the Steering Committee until June, 1975. There had been three trips to New York for these meetings. On the first visit, I requested the Rhinelander Galleries of the New York Hilton for the Art Exhibition. The Art Committee had already met in Minneapolis and had aired the suggestions and complaints of previous chairmen and artists. All requested that the art exhibition not be located in the Colosseum. Also we had begun negotiations for our special exhibits. Thankfully we were tentatively assigned the Rhinelander Galleries on that first New York trip and kept them.

## SELECTIONS OF ART WORK

A Gantt chart prepared for the year called for submission by January 30 of a description of each piece of art the artists desired to submit, its size, method of production, a suggested selling price — if it was for sale — and a facsimile of the art itself. This call for art had been prepared and sent out in October of 1975.

All plans had stayed close to schedule. The submitted art was reviewed in February. Acceptances and rejections were made at this time. Artists were notified in March.

A special form to be signed and returned by May 1, 1976 was sent to each accepted artist.

#### PLANNING OF SPACE

A floor plan of the Rhinelander Galleries had been prepared. The scale was 1/2" to 1', and it covered most of my living room. Less than a week ago, a friend and I had worked until 2:00 A.M., placing the 376 scaled pieces of art in their proper places.

#### D-DAY -- PUTTING UP THE EXHIBITION

But there had been no way of planning for the unexpected problems that arose, even knowing about the New York labor unions. Yesterday, the devoted committee started assembling at 7:30 A.M. My right hand controller was Kurt Lauckner, in charge at the New York Hilton, while I helped decide where the 7' X 9' portrait of George Washington was to be hung, and where the posters were to be placed in the Colosseum.

Data General, true to their promise, had the 5,000 complimentary copies of the lists of artists and their works ready. The center of the booklet had the picture of George Washington by E. T. Manning shown in the Colosseum (on the opposite page). Data General had been excellent in their efficiency and cooperation. The proofing of the copies in the middle of May had been made much easier because of them.

Again my mind wandered back to June 5 and its difficulties. On Saturday morning the rugs were not laid as promised, and the laborers showed up late. They could not place the drapery material on which the pictures were to be hung until the rugs were down. The cork boards -- so they insisted -- had to be put down last. The committee had unpacked art works, labeled them, and had done everything they could do and waited -- and waited! The first cork board was finally put up at 4:00 P.M., only twenty-four hours before the scheduled art opening. Only very shortly before that time had the first gold drapery material been put in place. The patience of the art committee was phenomenal. By 6:00 P.M. the drapes had proved to be too thin to hold most of the large pictures, and the floor plan had to be changed.

There was a deadline of 4:00 P.M. for Sunday, June 6 for the opening! In May, just the thought of hanging 376 works of art in 32 hours was enough for nightmares, but the committee now had less than 24 hours.

#### THE EXHIBITION - FLASHBACK

At this moment I was taking the golden scissors from my bag and handing them to his excellency, the Canadian Consul General, and the blue ribbon signalling the opening of the Art Exhibition was being cut. I opened the door, looked at the huge exhibition of computer art and thought, "What a wonderful committee I have had! This is truly a fine exhibition by many superior people."

The reception area to the right revealed a 7' X 9' portrait of Abraham Lincoln and a smaller Blockpix image of stardust. There were two baskets of flowers on the center table. On the tables to the left were the guest book; the silver tray holding 3" souvenir buttons with our logo, frog called "Princely Potential" by Jean Bevis; copies of souvenir booklets of the exhibition, one printed

at the courtesy of Data General, and the other by Computra, Inc., Upland, Indiana -- and information about our special exhibits, including special gallery tours. Ahead was the Systems Dimensions, Ltd. Collection, which was shown for the first time in this country. It was composed of ten computer designed serigraphs commissioned by SDL from artists in Europe, the United States, Canada, and the Far East. These ten 4' X 4' serigraphs were hung on their own aluminum pedestals and were on either side of a 9' carpeted aisle. The attendees could enter that aisle or another parallel one -- both of which exited from the reception area -- and were seen through the door. Along the right wall of the aisle were four "Oscillons" loaned by Ben Laposky. There were arrows pointing to Adventure Trails, to allow an orderly flow of visitors to the gallery.

Beyond the SDL exhibit were a group of famous works loaned by CalComp: the "Mona Lisa", "The Fisherman", "Pagoda", "Young Thinker", the "Proud Peacock", and "Digital Aquarium". Alongside these were several Japanese works. The Consul General was quite interested in Dr. Henry Christiansen's "Collection of Finite Element Analysis" works, which Dr. Christiansen called "Computers for people who can't read but love to look at pictures".

As we toured the exhibit, the safety pins that hung some of the wire to the gold cloths thankfully did not show. Also it was obvious that the wires on the cork boards, connected with shower curtains and drapery hooks were an ingenious (and not unæsthetic) solution to hanging heavier art works. What an ingenious committee!

As we continued that first tour of the gallery, the group of invited dignitaries noted the playing cards by Carl Hamner, the series of Netherland stamps, a 4' X 5' tapestry made of jute and wool by Susan Sirkus, weighing approximately 20 pounds, materials designed with the aid of computer graphics. Especially noted was the powerful and delightful special ICCH/2 Exhibition gathered by Grace Hertlein. Truly this was the most unique, largest and most international art exhibit ever shown at a large computer conference.

The dignitaries were impressed with the fact that for the first time at any AFIPS conference there was to be an ongoing silent auction of some of the works of art. Our original plan of writing on the cards provided near each work (for bids) did not work out. By Tuesday, we had changed to a notebook in which bids and names of bidders were written.

Ahead of us just a little hidden by the gold skirts which separated the entrance and exit doors, was the 7' X 9' scanchrome of Abraham Lincoln by E. T. Manning. It looked magnificent, according to the comments of the innumerable guests.

As I thanked them for their participation in this special opening and accepted their well wishes, I knew we had a hit on our hands!

As a parting note, I would like to thank not only the dedicated Art Committee, but also the artists and all those who made possible this truly international computer art exhibition, in which art is the universal language.



# GRAPHICS APPLICATIONS IN THE ENVIRONMENT: GROUPE COULEUR DE BELFORT

by G. F. Kammerer-Luka  
10, Rue Marceau  
90000 Belfort, France

"The originality or uniqueness of the Belfort group lies in the practical aims of its research and products, taking art into the environment of the citizens...The objective had been reached — the fruit of a common effort between artists and computer technicians...Artistic creativity and computer technology are compatible."

## FORMATION OF THE GROUP

The Groupe Couleur (or Color Group) of Belfort was originally formed in 1968 by the painters: Kammerer-Luka, Nadal, and Normand. The group proposed to work with those responsible for the humanization of the industrial and urban environment in the Belfort region, working through the medium of color.

The originality or uniqueness of the Belfort group lies in the practical aims of its research and creativity, taking art into the environment of the citizens. Thus we are continuing the ideals of the Bauhaus in Germany, whose great work began at the beginning of this century.

The Groupe Couleur, acting as a link between conceptual creation and final execution, works in collaboration with architects, planners, and institutes, etc., and increases contacts with the inhabitants of Belfort and its students, involving them in our projects. Our aim is to integrate the lifestyle and urban background of the Belfort citizens into artistic creations that are a vital part of the environment.

After two years' efforts, amidst certain difficulties that included variables outside our control, the first realizations of our work saw the light. Some of these variables were: decisions, financing, and attitudes of the public authorities, users' receptions to our work, etc.

## CHRONOLOGY OF EVENTS

Before discussing some of our varied projects in detail, a brief chronology of our efforts is given:



ABOVE: G. F. Kammerer-Luka, Animateur, Groupe de Belfort; Marcel Kibler, Professor of Mathematics; and J. B. Kempf.

1969 - Sensitization campaign, with conferences and exhibitions. First realization: planning of external and internal color scheme in the Mechanical Workshops of the Social and Interprofessional Center at Exincourt, Department 25.

1971 - Foundation of a civic society, the Groupe Couleur de Belfort, with G. F. Kammerer-Luka, Claude Noll, Yves Normand, and Anne-Marie Quemar.

Realization: Color scheme of the Z.U.P. (Council Flats Estate) in the Glacis district of Belfort - program of 300 flats.

1972 - Study for the subway at the Belfort station, with collaboration of J. B. Kempf and Marcel Kibler and new computer-aided research.

BELOW: A study of the "monumental tapestries" or murals for modular decoration.

Color scheme for the Mechanical Engineering Workshop at The Technological Institute,

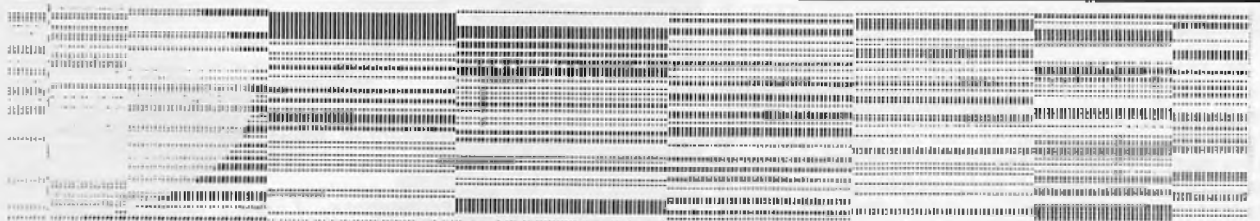

Couthenans, Department 70 — School plan and external color scheme.

1973 - Computer-generated mural decoration for the entrance hall of the Engineering Department of the Technological Institute at Belfort.

Color scheme for the second section of the Glacis Estate, a program of 600 flats, Glacis school, color scheme.

Participation in the SIGMA 9 Exhibition, "Art and the Computer" in Bordeaux.

1974 - Participation in the "Art and Computing Exhibition" in Angers.

Research into modular art with regard to its application in industry.

#### A GROUP OF ARTISTS WORKING WITH COMPUTERS - 1972

Artistic creativity and computer technology are compatible. This was the essential experience of our collaboration with the computer. It began in 1972 with the arrangement of the underground passageway near the Belfort station: a study of the lighting, and mural decorations of a subway some 60 metres in length.

These dimensions in themselves exceeded the usual framework of artistic intervention (or collaboration) in public buildings. Thus was born the idea of associating with the Computing Department of the Institute of Technology, with research into plastic materials. Thanks to the competence of an E.E.I.P. engineer, J. B. Kempf, who is in charge of Mathematics and has recently turned computer specialist, we were able to accomplish this new task.

With a sense of wariness and caution, the group began the work it had conceived — on a parallel with the computer and the drawing board. But this parallel work rapidly turned into a dialog.

#### THE NEED FOR ANALYSIS

It was our computer specialist who was the first to point out to the artists the necessity for previous, rigorous analysis of all the parameters which compose or make up the whole. These analytical proceedings of the computer specialist, when faced with a work of art which attempts to be a synthesis of art and science, may be paralyzing rather than inspiring.

Under one condition did collaboration between

artists and computer experts become feasible: that is, by determining together the elements of the composition and by defining the assemblage of these parts which made up the whole. This formed the basis of many a long discussion, often illustrated by a sketch when ordinary speech proved insufficient, or when the discussions began to slip into aesthetic or philosophical speculations.

#### SUGGESTED SOLUTIONS TO THE SUBWAY MURALS

The installation of the lighting effects had to comply with two rules, the first objective, and the second, subjective:

1. The lighting system required sufficient abundance according to specified illumination standards dictated by the technical specialists, and also a progressive transition in the intensity of light toward the subject exits to avoid dazzle.

2. The sensation of the length in the corridor (60 metres) had to be reduced by dividing it into sections with vertically and evenly spaced neon tubes, thus reducing the space of the median zone, in order to create a sensation of acceleration.

We asked our computer expert to do no more and no less than to incorporate "complexity of imagination", even "sensitivity" into the programs. The successful continuation of our work was to depend on the solution to this postulate.

But how are we to simulate the complex act of "imagination" by means of the computer? Any kind of simulation of creative art by rational methods forms a vicious circle, a crucial dilemma — that is, to escape from the grip of mathematical laws by rational means — and to attain art.

Yet from that moment onward, any possibility of achieving computer art will depend on the reconciliation of the real and the imaginary, of calculation and chance. Mathematical probabilists open up the way by using pseudo-hazardous series (pseudo-randomizations), that is, numbers by chance. From now on, these "numbers by chance" will play the role of "imagination", of artificial generators of complexity, whose volume will later need to be dominated and analyzed by the artists, according to the aesthetic objective that is envisaged. For 100% chance causes utter chaos, in our opinion, and is not always artistic.

BELOW: Further examples of studies for murals in ceramics, aluminum, etc. from printer output.

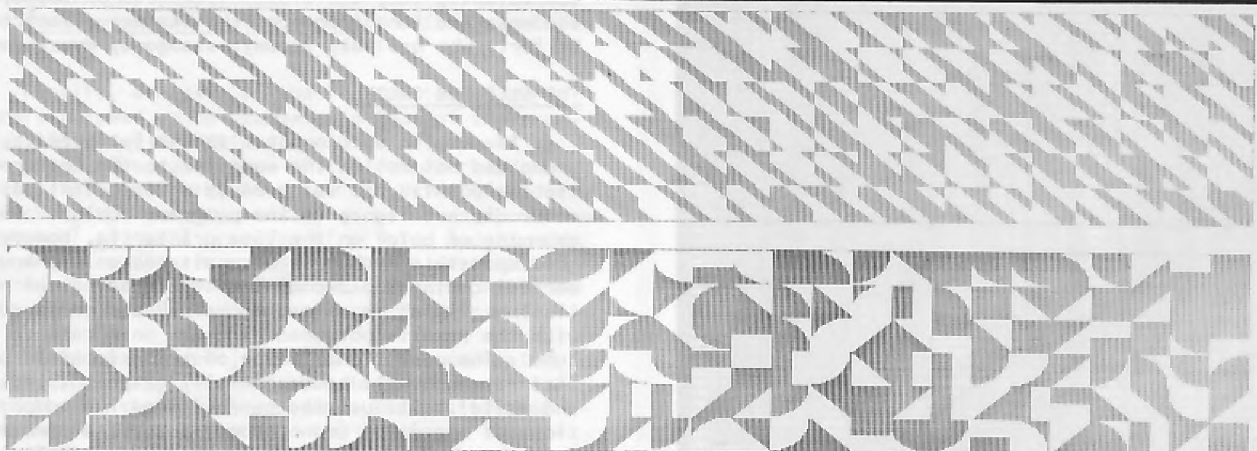



ABOVE: Fish-like forms vie with rectilinear patterns, but a few explored for monumental murals in the environment. The more abstract the patterns, the greater the number of potential variations.

#### PROGRAMMING AND PLANNING THE SUBWAY MURALS

As far as mural decorations were concerned, the components were simple: squares of Buchtal ceramic (30 X 30, 30 X 60, and 60 X 60 cm.), laid out in vertical strips of varying width. The entire efforts of the plastician were to depend on combinations of these elements.

BELOW: A sample of the vertical designs generated for the subway murals.

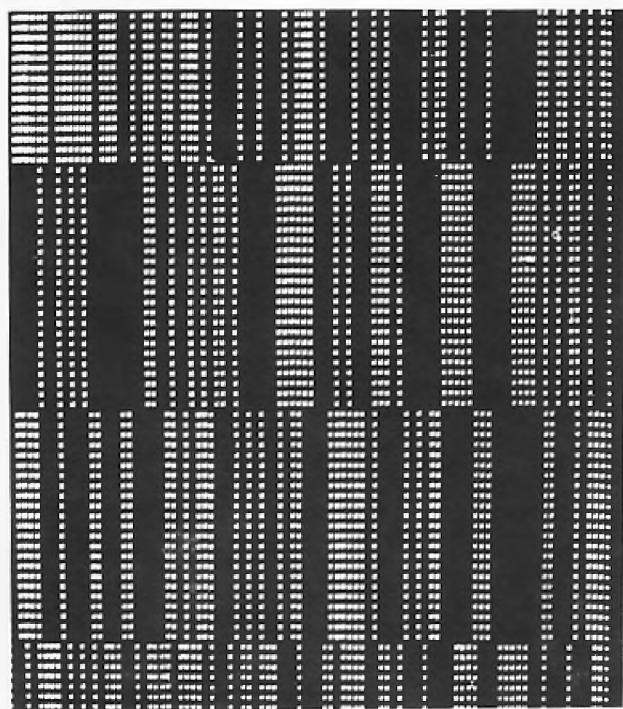

The first program used for introducing chance into the calculation of the disposition of the vertical strips produced a linear graph on the printer with a juxtaposition of patterns varying practically to infinity.

The computer scientist suggested a Fibonacci Series (of the  $U_n - U_{n-1} = U_{n-2} \dots$  type), to be generated by the computer in systematic application. Alas, such slow completion of the program tried the patience of the group, so that they attempted other solutions — but all planned solutions were conceived in a mathematical series. This was the first effect of rational computer methods on the work of the Belfort group.

Even if at first we let ourselves be carried away by the plastic imitation of a simple mathematical formula, this could not be said to be the case for the mural decorations. In fact, the problem was to find a true plastic (art) quality in these metres in question, to find a "living rhythm" thanks to the larger complexity in the composition — in order to sufficiently vary the visual sequences of the 2,000 students and inhabitants of the Western districts of Belfort, who use this subway passageway every day.

#### THE NEED FOR COLOR

If despite our computer specialist's feats, the group did not follow the computer to the letter or "to the points", it was because an important parameter did not figure in the program: color. Programming of color on the line printer is, however, not impossible — but it necessitates an alphanumerical coding and decoding of the readings of the listings, which is a fastidious process compared with the results obtained directly on a cathode ray tube. The operational value of the printer in plastics research will be essentially graphic (black and white). Its use may be envisaged for compositions of one color (monochrome) for for a number of

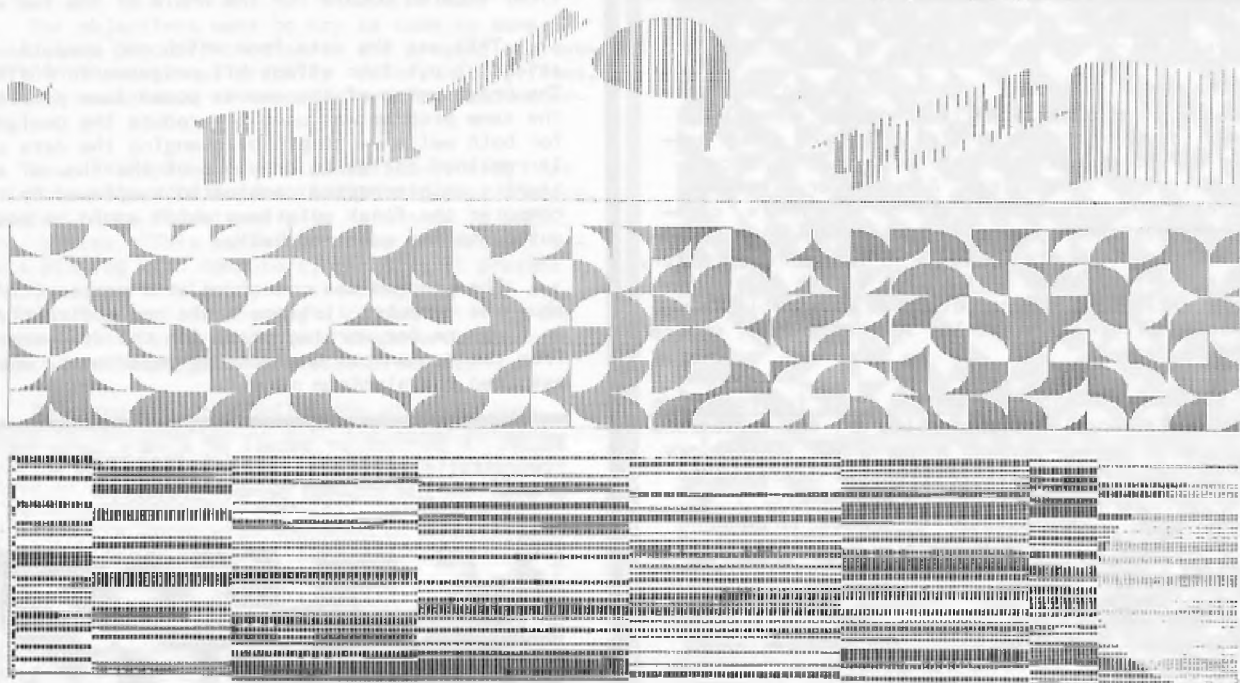

ABOVE: Further examples of the innumerable permutations of form from which the artist may choose. It is our hope to make a television film of the permutations, to more fully reveal the family of forms achieved.

reduced colors (contrasting polychromy).

RESULTS

It was a complete success: for on the line printer appeared, without the slightest discontinuation (paper skip) or repetition, the most varied and unexpected propositions, of which the few illustrations given here can give but a poor idea of the possibilities of the program, and the beauty of the results obtained.

The objective had been reached — the fruit of a common effort between artists and computer technicians. To sum up this experiment, working with the computer is slower initially in the program-writing stage, but more efficient than the traditional methods of conceptualization of the work by hand. The superiority of using the computer is that practically unlimited numbers of scanning sketches of the artistic problem can be quickly achieved. Thus the definitive choice of the work to be done may be effected after consideration of the immense sampling via computer, which opens up the way to greater aesthetic quality.

Finally, analysis of the realization of our murals allowed us to become conscious of the creative limits of traditional methods as opposed to the productive capacities of the computer and the artist. Thenceforth, in the elaboration of modular sketches, the computer was to serve us as a combination tool and as a producer of printed models. We found that endless new research paths were to be opened up to our group from this creative alliance with the computer and computer specialists.

What does the project of the mural decoration of the subway station owe then to the computer? With the contact of the prodigious capacities of combinations visualized and the listings, the artist feels liberated — feels his imagination has

been unleashed, and pushed to a higher degree of originality.

MURAL SCULPTURE IN SHEET METAL - SUBWAY EXTERIOR

In addition to the underground murals for the Belfort subway, the western exit or exterior of the under-rail passage was to be embellished by a high

BELOW, RIGHT: Detail of a larger design for murals. Imagine these (and the others) in monumental sizes.

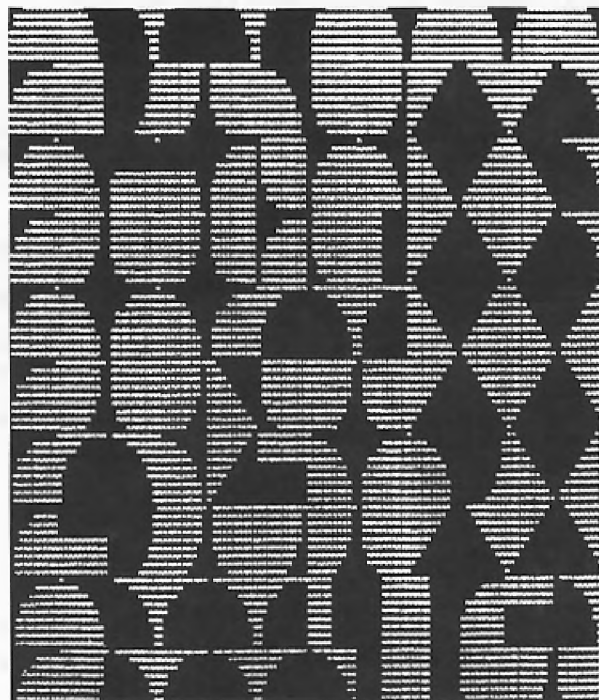

relief mural whose surface quality should be compatible with the ceramic enamel of the subway interior walls, in 60 X 60 cm. squares.

The mural sculpture that was designed in sheet-steel took on then, formally speaking, a modular aspect (squares and rectangles), and the group produced only one model made by hand, under the careful control of aesthetics. After several attempts to create a satisfactory state for the whole, creative impetus came to a halt. Since the interchangeable combinations are infinite in using the computer, they never take shape in the same way as in traditional art. Here the computer was invaluable in providing alternative models, so that a final choice could be made.

The computer alone, exempted as it is from human fatigue, is capable of generating all the variations of a model, thus enriching the world of shapes in a prodigious manner. To use manual art processes to explore all these variations is impossible.

Yet we made another discovery: the programs which we used (with definite aims in mind for our first project, the ceramic murals) to make vertical and horizontal explorations, could be used for the generation of many other forms and designs. The multi-dimensional exploitation of programs could be achieved by changing the control data, by introducing variants of all types, by modifying the modules and the ranges of contrast, and by acting on probabilities and chance.

We are at the source of the world of forms.

#### COMPUTER-GENERATED MODULAR DECORATION - 1973

The opportunity for further research presented itself in 1973. The Technological Institute of Belfort had the previous year held its first exhibition of computerized art. We were invited to decorate two walls of the entrance hall of the Mechanical Engineering Department, a surface area of about 50 square metres.

For the two walls in the Mechanical Engineering Department, we desired two differing forms of design. Flowing along wall #1, which the students pass by every day, thus blending in with the daily movement in the entrance wall we chose these modules: the circle being the organic form par excellence, was to furnish us with the modules for this wall (quarters of circles inscribed in a modular square with positive and negative areas, making 8 modules in all).

We asked our computer expert for the equiprobable occurrence of each module, in order to obtain a high degree of animation by variety and complexity. The dimensioning was calculated in accordance with the cross-ruling of the ceiling, and superimposed in six rows, also to integrate the decoration to a maximum effect with the architectural environment. After that came the choice of the material. Since we were working with the Mechanical Engineering Department, sheet aluminum was chosen for its low cost.

On the opposite side, however, on wall #2, is a static structured composition, which should appeal more strongly to a technician's imagination. As for wall #2, the same procedure was followed, except that the modules were drawn out of the circle by cutting the latter in two directions (at 45° and 90°). We obtained ten or so figures: squares, rectangles, triangles, all inscribed with an iden-

tical squared module for the whole of the two walls.

This was the data from which our computer scientist put into effect his programs in FORTRAN. The programming of the curves posed some problems. The same program was used to produce the designs for both walls — simply by changing the data cards. It remained for us to draw out of the flow of arbitrarily uninterrupted combinations offered by the computer the final solutions which would be best suited to the entrance hall.

The program was conceived at a scale of 1/10, thus the computer listings could serve directly as an exposure (or working plan) for the students from the Mechanical Engineering Department, who executed the aluminum murals.

---

BELOW: A portion or detail of a very large work, "Exploitation Quantitative et Qualitative du Programme" — IBM 370-168 Benson plotter.

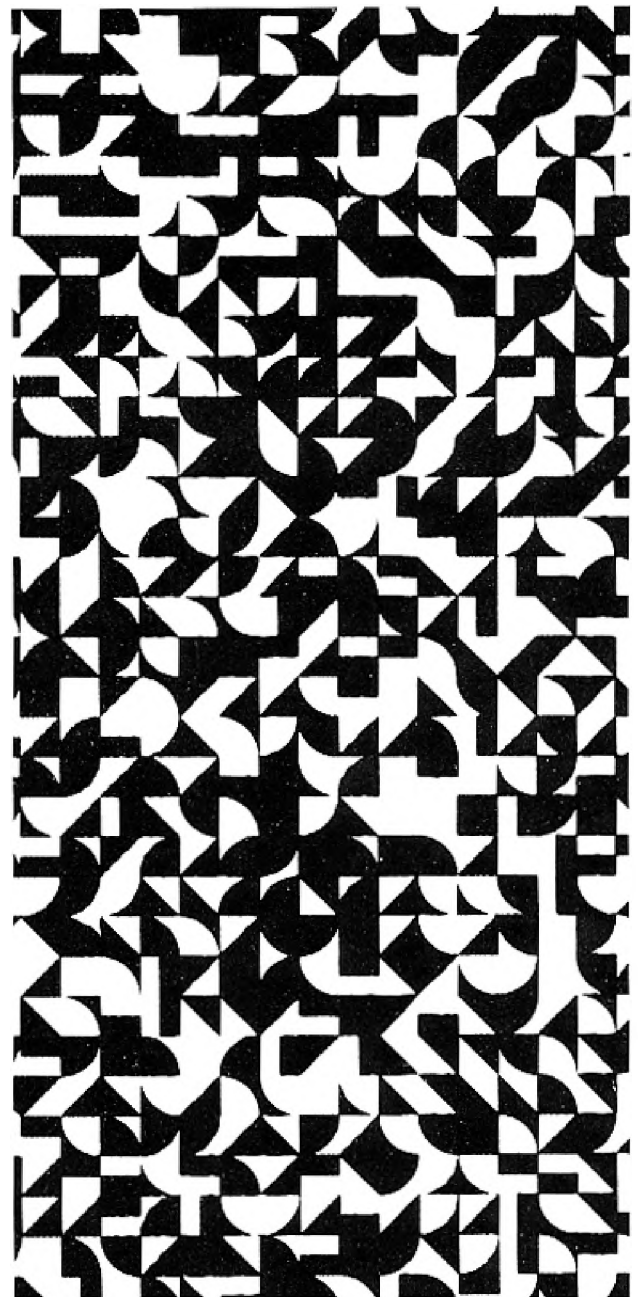

Our objectives were to try to come to some conclusions on current research and present achievements in the realm of graphics, color, music, films, with the assistance of computer programs and material.

We participated in the exhibition titled "Art et Informatique" in Angers in 1974. Daniel Chompre, Animator, Arts Plastiques a la Maison de la Culture, wrote: "This exhibition does not present artists playing with computers, nor does it present computer experts playing at creating works of art, but computer artists sharing a common activity and common tools: programming and computers, which finds a special type of artistic practice."

In discussing the philosophy of using computers in the creation of art, the noted authority on contemporary aesthetics, Abraham Moles, Director of the Social Psychology Institute, of Strasbourg University commented: "From now onwards, we are faced with the problem of establishing an art form on a total social scale, rather than on an individual scale. However, art still remains the 'message' from one individual, the artist, to another. Thus we need another method of aesthetic communication. Will machines and their work, which some artists have unconsciously advanced, be able to respond to this new social and artistic dimension?"

In 1976 the group participated in the Exposition au Centre d'Art et de Recherche Plastique Architecturale in Paris.

#### SUMMARY

We may ask, "Why this profusion of forms, this vast complex of computer-generated works?" This leads us to one or two fundamental reflections on the role which computer art will be called on to play in our industrial civilization, the latter way of life having barely begun for the majority of humanity.

With the increased use of computer-generated art, the popularity (or desire for) computer art will proliferate every form of art, including the decorative arts. Due to the densification of housing around places of work, a growing need for quality plastics will make itself felt in our artificial environment. The computer alone will be able to supply to our satisfaction, both quantitatively and qualitatively, original works of art which thus will humanize our community life at the close of the 20th century.

But it is essential for the artist to dominate (or control) the relationship between order and disorder, logic and chance, the dialog between form and anti-form, all of which vivify a work of art. In short, to orchestrate a whole by starting from a few basic elements, as in musical composition. It is to this end that we are urged by computer art, which may become a powerful tool in the hands of artists.

That is why architects and men in industry should begin to investigate computer art. At that moment, and only then, will we abandon the purely repetitive, impersonal principle present in the building industry.

By programming computer art as soon as it is conceived, the latter will be able to make an entry

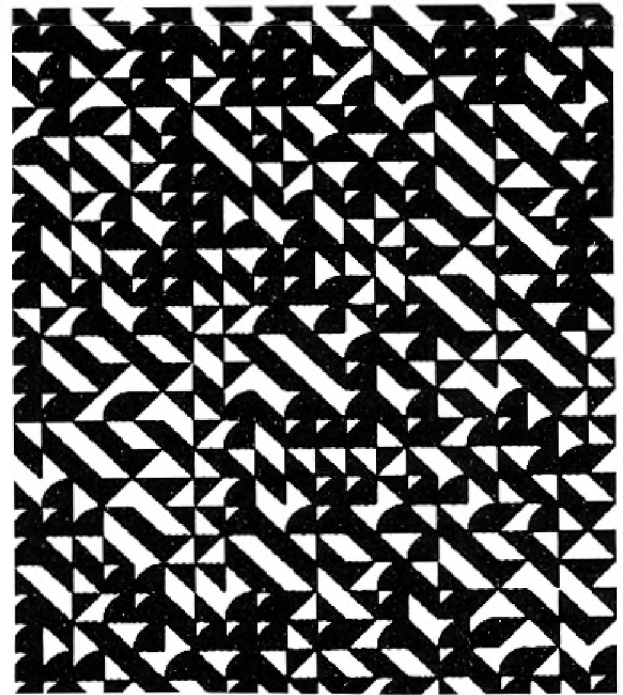

ABOVE: Another variation of the "Exploitation Quantitative et Qualitative du Programme" — a detail of a much larger work.

into the assembly lines, since it speaks in the same language — molds for preassembled concrete, and for plastic plating or tiling to correspond to the computer's design modules — authentic, infinitely variable decorative panels will be produced with the help of numerical control.

This imagination offered by the computer will enter into the industrial manufacturing processes of tomorrow. But when shall we see the wallpaper industry, the decorative fabrics industries, the clothing, weaving and tapestry industries opening their drawing offices and their workshops to the computer?

When the doors become open to the potential of the computer, we will realize at last the dream of design, the industrial aesthetics proclaimed by the great plasticians at the beginning of this century in the Bauhaus, by Le Corbusier in France, and by so many other great artists. This will involve adapting art to technological civilization and its computer-oriented manufacturing processes which animates for us the world of forms hitherto manual and primitive.

Computer art permits the effective participation of its users at many levels of choice without any loss in quality but implies the condition that users may screen the results obtained to correspond in an optimized manner to the aesthetic criteria established in advance. This is a step towards democratization of quality art in the realm of mural decoration which died out with the craftsmen of the nineteenth century.

In summary, the computer offers to us the possibility of recreating a plastic vocabulary and system according to the needs and means of modern production, without sustaining a loss in the quality of art. We will then experience a renewal of decorative art, which will become, by virtue of its universality, a new world form of popular art.

# computers and people

formerly *Computers and Automation*

## computers and people

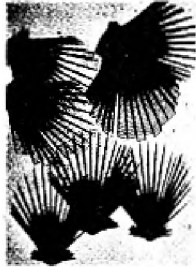

SEA FANS

*Published by:*

Berkeley Enterprises, Inc.  
815 Washington St.  
Newtonville, Mass. 02160  
617-332-5453

## computers and people

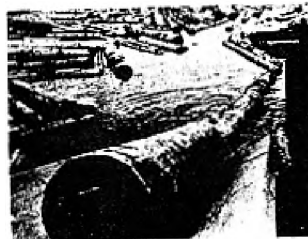

RAW INPUT FOR LUMBER  
MILL AND COMPUTER

## computers and people



WEATHER-  
WATCHING  
BUOY

### HOW CAN YOU KEEP UP-TO-DATE WITH THE COMPUTER REVOLUTION?

If you read *Computers and People* (formerly *Computers and Automation*) your job will be easier, your efforts will be less.

*Computers and People* provides significant, clear and useful information that you need, in order to understand and apply computers and data processing effectively — both now and in the future when computers, we believe, will become commoner than motor cars. We help you comprehend the fastest growing industry in the world.

*Computers and People* is the oldest magazine in the computer field, published since 1951. It is edited by computer pioneer Edmund C. Berkeley. He took part in building and operating the first automatic computers, the Mark I and II at Harvard University in 1944-45; in 1965-67 he implemented the programming language LISP for the DEC PDP-9 computer. He is: a founder of the Association for Computing Machinery; its secretary 1947-53; the author of fourteen books on computers and other subjects; a Fellow of the Society of Actuaries; and an invited lecturer on computers in the United States, Canada, England, Japan, the Soviet Union, and Australia.

He is assisted by able associates and contributing editors who help report the concepts, applications, and implications of information processing systems — with emphasis on ideas, issues, controversies, society, people, and social responsibility.

Take a quick look at the summary here of the contents of *Computers and People* — then ask yourself: "Would this information advance the goals of my organization, and my personal goals, in the Computer Revolution?"

## computers and people

Each issue of *Computers and People*, formerly *Computers and Automation*, contains articles of significance on important aspects of the computer field and related fields. Here are some samples:

### Computers and Monopoly

R. M. Carlson and B. Wehrmann, U.S. Dept. of Justice  
IBM and the Maintenance of Monopoly Power  
Dan L. McGurk, President, Computer Industry Assoc.  
Competitive Restructuring of Monopoly Situations

### Computers and Privacy

Prof. Alan F. Westin, Columbia University  
Databanks in a Free Society  
Governor Francis W. Sargent, Commonwealth of Mass.  
National Crime Information and Massachusetts  
Pres. Jerome B. Wiesner, Mass. Inst. of Technology  
The Prospects of "Information Tyranny"  
Vern Countryman, Harvard Law School  
Computers and Dossiers

Computers and Crime

- Donn B. Parker, Stanford Research Institute**  
The Antisocial Use of Computers
- Richard E. Sprague, President, Personal Data Services**  
The Assassination of President Kennedy: Computer Applications to the Photographic Evidence
- Raymond E. Boche, Calif. State Univ.—San Luis Obispo**  
System Software Deciphering and "Cracking"

Computers and the World

- Dr. Stafford Beer, Manchester University, Great Britain**  
Managing Modern Complexity
- C. P. Snow, Ministry of Technology, London, England**  
Science and the Advanced Society
- John Kenneth Galbraith, Harvard University**  
Employment, Education, and the Industrial System
- Dr. Ruth M. Davis, National Bureau of Standards**  
Computers and the International Balance of Power
- C. W. Spangle, Vice President, Honeywell Inc.**  
The Present Role of Governments in the World Computer Industry

Computers and the Mind of Man

- Dr. Richard W. Hamming, Bell Telephone Labs, Inc.**  
The Computer and the Intellectual Frontier
- Dr. Donald E. Knuth, Stanford University**  
Computer Science and Its Relation to Mathematics
- Prof. Grace C. Hartlein, Calif. State University, Chico**  
Computer Art for the Artist
- Prof. Joseph Raben, Queens College, N.Y.**  
Computers and the Future of Education
- Wayne E. Shufelt, Sperry Rand Univac**  
Pictures of Mars by Mariner and by Computer
- Lawrence M. Clark, Framingham, Mass.**  
Languages Among Computers, Machines, Animals and Men

Computer Programming

- David W. Packer, Digital Equipment Corp.**  
Effective Program Design
- L. H. Crandon, RCA, and P. G. Anderson,**  
**Newark College of Engineering**  
Computer Program Reliability
- E. C. Berkeley and C. Otten, Berkeley Enterprises**  
Computer Programming Using Natural Language

Computer Applications

- Colonel T. B. Mancinelli, U.S. Naval War College**  
The Trouble With Management Information Systems
- Edward N. Cole, President, General Motors Corp.**  
The Automotive Industry and the Computer Industry
- J. W. Germany, Vice President, Southern Pacific**  
The Railroads and Computer Control
- Frank Burnside, President, Fowler Dick and Walker,**  
**Wilkes-Barre, Pa.**  
Point of Sale Equipment for Retail Stores
- Prof. Gene F. Franklin, Stanford Univ., California**  
Computing Facilities at Stanford Univ.:  
Their Development and Direction

Computers and Social Responsibility

- Dr. Harvey S. Gellman, DCF Systems, Ltd.**  
The Social Responsibility of Computer Specialists
- Ralph Nader, Attorney and Consumer Advocate**  
Computers and the Consumer
- Richard E. Sprague, President, Personal Data Services**  
Computer Professionals: What Their  
Social Concerns Need to Be
- Prof. Charles Susskind, Univ. of Calif. at Berkeley**  
Technology as a Social Force and Ethical Problem

**SPECIAL ISSUE**

**THE COMPUTER DIRECTORY AND BUYERS' GUIDE,**

the midyear reference issue of *Computers and People*, formerly *Computers and Automation*, published every year since 1955, is a special 13th issue. It is a basic buyers' guide to the organizations, products, and services available for supplying, designing, and using computing and data processing systems.

This issue contains over 20 kinds of reference information, such as:

- Roster of Organizations in the Computer Field
- Buyers' Guide to Products and Services
- Characteristics of General Purpose Digital Computers
- Over 2500 Applications of Computers
- Roster of General-Purpose Programming Languages and much more

Well, wouldn't this information advance your goals in the Computer Revolution? Why not fill in the coupon below and mail it now?

**THERE IS NO RISK!**

If at anytime you feel that *Computers and People* is not supplying you with useful information and ideas, tell us and we will promptly refund to you the value of the unmailed portion of your subscription.

**TO: COMPUTERS AND PEOPLE**  
**BERKELEY ENTERPRISES, INC.**  
 815 Washington St., Newtonville, MA 02160

YES, start my subscription to **COMPUTERS AND PEOPLE** according to the instructions checked below.

One year (13 issues with the Computer Directory and Buyers' Guide) \$23.50\*

One year (12 issues without the Computer Directory and Buyers' Guide) \$11.50\*

\* Canada, add \$1.00 a year; foreign, add \$6.00 a year.

Payment enclosed       Bill my organization

---

Signature \_\_\_\_\_ Purchase Order Number \_\_\_\_\_  
 My name and address are attached

