

RCA

Electronic Age

Summer 1969

U. of ILL. LIBRARY

OCT 1 1969

CHICAGO CIRCLE



Cover: The speed and immensity of the upcoming new age of aviation are captured by the blur of a jetliner. It will be an age of supersonic travel, an era in which 600 people will be able to cross oceans and continents in a single plane, and an era of short-distance midtown-to-midtown flights. For a report on the future of commercial aviation, turn to page 22.

Electronic Age

Published
Quarterly by

RCA

30 Rockefeller Plaza
New York, NY 10020

© 1969, RCA—all rights reserved. For permission to reprint or reproduce any portion of the magazine, write to the Editor, Electronic Age, 30 Rockefeller Plaza, New York, NY 10020. Printed in USA.

When requesting a change of address, please include the code letters and numbers appearing with stenciled address.

Editor
JULES KOSLOW

Associate Editor
Norman H. Solon

Assistant Editor
Mary Jeanne Carlson

Editorial Assistant
Ann Ovodow

Production Associate
Britton G. Bailey

Production Assistant
James W. Rostron

Design Consultant
Sheldon Seidler

Contents

Summer 1969 Vol. 28/No. 3

- | | | |
|----|---|---------------------|
| 2 | Computers in Russia
A report on computers in the Soviet Union. | by Richard B. Rush |
| 8 | The Grand Tour of the Planets
By the late 1980s, man may have taken a close-up TV look at every planet in the solar system. | by Dr. I. M. Levitt |
| 12 | Art and the Computer
The use of the computer as a tool of the artist. | by Tom Shachtman |
| 17 | The Best-Seller Phenomenon
America's reading habits are both influenced and mirrored by best-seller lists. | by Roger Smith |
| 21 | For the Records . . .
News of recent outstanding RCA recordings. | |
| 22 | Aviation: On the Threshold of a New Era
Jumbo jets, airbuses, SSTs and STOL aircraft will help commercial aviation cope with the passenger boom of the 1970s. | by Norman H. Solon |
| 28 | Young Scientists of Today
A profile of young men in the laboratories of modern industry. | by Nicholas King |
| 31 | This Electronic Age . . .
A page of cartoons. | |
| 32 | Life in the Press Box
The working environment of the sports reporter is changing. | by Joe Garagiola |
| 35 | Books at Random . . .
News of recent books published by Random House. | |
| 36 | Electronically Speaking . . .
News in brief of current developments in electronics. | |

ЭЛЕКТРОННО-ВЫЧИСЛИТЕЛЬНАЯ МАШИНА

Электронно-вычислительная Машина. The Russians call it EVM for short, meaning "electronic calculating machine." To Americans, it is a computer.

by Richard B. Rush

The Russians, who once were dubious about the economic role of electronic data processing, now are using computers extensively. According to reliable sources, they are attempting to computerize most facets of their economy, but they have disclosed little concerning how or to what extent they use EDP equipment. However, it is fairly well known by Western scientists and trade officials who have visited the USSR that: the Soviets are still some four to five years behind this country in the design of digital devices, although not necessarily analog

equipment; mass production of either variety is limited; most digital systems are dedicated (geared for a single project) rather than general purpose; and, even with special training facilities, the lack of qualified programmers, analysts and systems operators continues to be a major problem.

Despite these deficiencies, the Russians may well be the world leaders in getting the most out of the computers they do possess. In fact, there is every indication that they are aware of the latest methods of business and scientific appli-

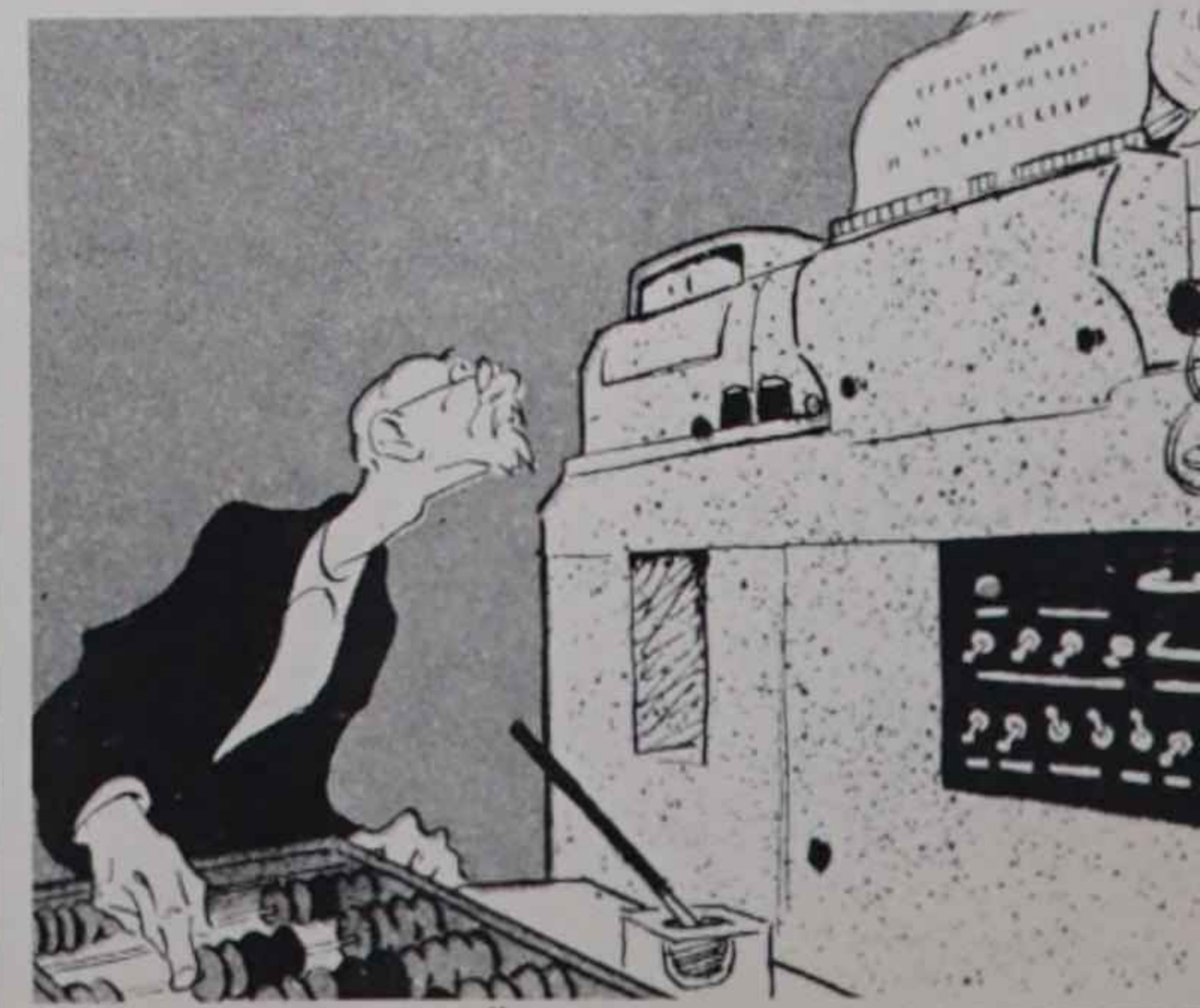

Машина машиной, а проверить все-таки не м...
("A machine is a machine, but it won't hurt to ch...

ПРООННО СЛИТЕЛЪ ДАШИНА

cation — much of this knowledge coming from U.S. publications. Most professional observers believe they are attempting to apply computers to the same fields and disciplines as is being done in America.

In the use of digital computers for scientific purposes, the Soviets probably are on a par or near par with most Western nations. The evidence is in their launching of missiles, Sputniks, Luniks, Zonds, Soyuzes and other spacecraft ever since the mid-1950s. But it has been only within the last three years that major attention has been focused on economic applica-

tions of computers, with their use pinpointed at optimizing production, distribution, planning and administration. This new focus is probably, in large part, the result of recent concentrated Russian participation in international computer conferences and the increased availability of Western computer-industry journals. For example, Anatoliy Dorodnitsyn, the Soviet computer expert, is president of the International Federation for Information Processing this year.

Many of these industrially applied computers are dedicated hardware de-

rived from previous experience in scientific computing and are limited by their relative slowness of operation and small information-handling capacity. Still, the Russians seem to achieve many of the same results as are obtained with general-purpose machines in this country.

Soviet designers, for instance, state that they have developed computer programs for 80 per cent of the nation's numerically (tape) controlled machine tools. If this is true, it is a higher proportion than that of any other country and about twice that of the United States. Certain Russian manufacturing plants also are using computers to make production-control decisions for management, to prescribe distribution of materials and to determine the duration of manpower deployment. In fact, most industrial fabrication processes are believed to be directed by a national link-up of specialized computer centers. Some Soviet planners are working on a computerized product classification system that, they say, eventually will lead to a central inventory of every product anywhere in the country.

In the transportation field, Aeroflot, the Soviet national airline, is using a computerized reservations system. However, it still takes 10 days to two weeks to get a reservation, probably owing to a shortage of airplanes and an excess of red tape. And the dispatching and routing of more than 30,000 buses and trucks in Moscow are based on computer-developed schedules. (Bus routing is computerized in Los Angeles and several other American cities.)

Big construction projects in the USSR are employing critical-path scheduling in much the same way as in Western countries. This is a computer-oriented planning technique in which all critical elements of a project are pinpointed, usually on the basis of time. Newer, more sophisticated applications also include such variables as costs, labor utilization and availability of raw materials.

In addition, GUM, the state-owned department store on Moscow's Red Square, is said to be fully computerized in the processing of sales and inventory data, as are many large U.S. retail establishments.

These and other current or planned socioeconomic uses of EDP give every indication that the Russians might be moving toward a totally computerized society. This is not surprising since the highly structured nature of their economy lends itself to the extensive applica-

tion of such methods. However, for this to be accomplished, considerable improvement probably will be needed in the number and quality of systems currently available.

Recent U.S. government and trade estimates place the Soviet digital computer inventory at somewhere between 5,000 and 8,000 systems, although only some 3,000 of these may actually be installed and operating. Almost all Soviet machines built in the 1960s are transistorized devices having ferrite core memories and operating at speeds in the comparatively slow range of 4,000 to 65,000 operations per second. One of the newest systems, the BESM-6 (*Bystrodeystvuyushchaya Elektronnaya Schityvayushchaya Mashina*, or high-speed electronic computing machine), is said to provide speeds in the range of 600,000 to 1-million operations per second — witnesses say 300,000 is probably more accurate — and that it can act in a time-sharing capacity serving up to 100 terminals. By comparison, some third-generation American computers function at speeds in excess of 1-billion operations a second.

In the slower speed, smaller scale configurations, Russian computers are considered by many to be the engineering equivalents of certain Western-made second-generation equipment. However, every Russian machine, regardless of vintage, seems to have a different tape or card format, and no program written for one processor seems to work on another. Also, the reliability of peripherals — tapes, disks, printers, etc. — is relatively low, and downtime often exceeds uptime by a considerable margin. Often, the peripherals are not even available. According to one U.S. government official, of the 12 to 15 BESM-6s that were believed to be in existence last year, four were unusable due to the lack of magnetic disks, tapes and/or printers, and another computer was only partially operational because of a lack of software.

It seems odd that a nation with a centrally administered economy apparently has no over-all government agency in charge of computer production, implementation and utilization. Even the development of peripherals and operating programs is not included in the list of responsibilities of the computer manufacturer — a condition that Victor M. Glushkov, a Soviet scientist and computer expert, describes as "tantamount to producing telephones without earpieces or cable." The user either must develop or secure his own.

This may be one of the reasons why so much Soviet computer activity emanates from 50 or more outside support organizations, some of which are affiliates or departments of universities. They are situated primarily in the major industrial centers and serve in research, programming, job processing and other computer-assistance capacities for manufacturers, government agencies and scientific institutions. Possibly the largest and best-known of these support groups is the Moscow Computing Center, which provides programming assistance to the Academy of Sciences. It also serves a wide range of organizations outside the Academy on what amounts to a commercial contract basis and does research work in such areas as pattern and sound recognition, data transmission and cathode-ray-tube display. The Center has a 400-man staff, of whom 250 are scientists and mathematicians.

Although these support organizations probably have been the primary reason for the rapid Russian rise in computer competence, they also have tended to siphon off the best of the nation's computer talent, leaving many industrial, economic and government agencies handicapped by a lack of qualified personnel. This condition now appears to be improving in that education of computer operators, programmers, technicians and development engineers is one of the major preoccupations of Soviet planners.

At present, some education of computer personnel is being undertaken within the framework of special studies offered in technical high schools. In addition, calculation institutes — created within the universities for the training of advanced students — provide a four-year curriculum of specialized analyst-programmer training. Shorter courses for programming and systems operators also are conducted at universities for personnel in industry and administrative

services — 10 months for programming and 20 days for operators.

At the most advanced level, the principal universities in Moscow, Leningrad, Kiev and Novosibirsk offer a five-year electronics engineering curriculum oriented toward computer design and application. In the first year, all students take a common program of general culture and electronics plus a special elective course in either mathematics or economics. During the next two years, students specializing in computer electronics and research are enrolled in a highly advanced 350-hour course of pure mathematics. Those students specializing in computer economic applications take an equivalent course in mathematical economics.

Finally, each student, within his specialty, undertakes practical, on-the-job training during his last two years in which he is assigned either to an institute of scientific computing and systems design or to an economic institution or industry for study and implementation of business and commercial procedures.

Each year, between 300 and 350 students graduate with engineering degrees from these different universities. This figure is up some 50 per cent over that of two years ago, but it is still a number that the Russian government deems insufficient to meet long-range personnel requirements. Over the next five years, Soviet officials hope that the number can be increased to around 1,000 a year.

The distribution of computer personnel between analysts and programmers in the Soviet Union also is significant in that it is the inverse of that of most Western nations. There are approximately 10 Russian scientific analysts for every programmer and some three to five management analysts for every programmer. In contrast, the average distribution of American computer personnel is approximately four scientific programmers to each analyst and seven management programmers for every analyst. Thus, in one respect, it appears that the Russians continue to be more intent on determining how and where to use the computer than they are with the actual mechanics of making the system work.

Work on the creation of EVMs began in wartime Russia about 25 years ago as a natural evolution of Soviet interest in

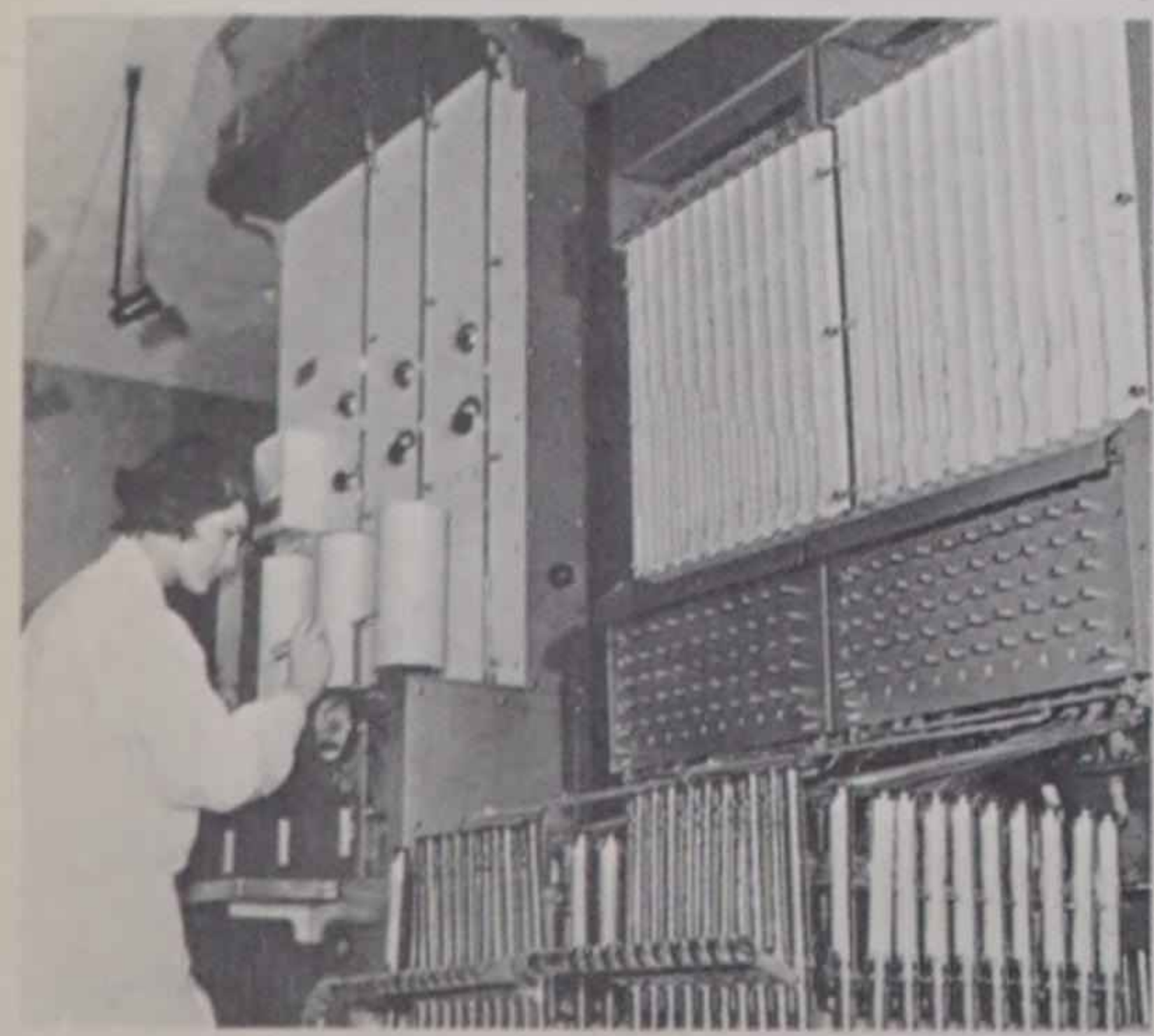

Russian technician checks a hydraulic integrator, a computing device for the construction industry.



Computer parts are assembled at a Kiev plant.



Technicians check Sirena computer system, used for processing seat reservations for Aeroflot flights.

kibernetika (cybernetics), although it was against government policy at the time.

Even as late as 1954, one year after Stalin's death, *Kratkiy Filosofskiy Slovar'* (*The Brief Philosophical Dictionary*) severely castigated research in and with computers as "a reactionary pseudoscience originating in the USA after World War II and spreading widely in other capitalistic countries as well . . . in essence aimed against materialistic dialectics . . . against the scientific Marxist understanding of the laws of societal life. . . ." EVMs and cybernetics were further derided because they "clearly expressed one of the basic characteristics of the bourgeois view of the world — its inhumanity, its attempt to transform toilers into mere appendages of the machine, into a tool of production and of war. . . ."

Such outcries emanated from Stalin's later-life fear of socialistic displacement. Not only did he associate computers and cybernetics almost wholly with one person — American mathematics Professor Norbert Wiener of MIT—but he was afraid that computers, in precise and coldly objective mathematical terms, ultimately might prove communism wrong and the Soviet philosophy antithetic of every scientific premise.

Fortunately for Russia, some of her top scientists, engineers and mathematicians semantically evaded Stalin's dictum. Had they adopted his definition of cybernetics, the Russian space program would still be sitting on the launching pad, since it is impossible to guide a spacecraft without a computer. Avoiding use of the words *elektronno-vychislitel'naya mashina*, they quietly continued backroom experimentation, drafting and building, and created computers despite official policy.

However, Russian engineers were not above adapting hardware technology from captured German sources and from vintage American data-processing machines confiscated from plants in Czechoslovakia. Programming was no major problem for the cyberneticists who had their nation's rich mathematical tradition behind them.

Indeed, Russia was well ahead of the rest of the world in the principles of programming. Linear programming, for example, was suggested by Leonid Kantorovich, a 27-year-old mathematician, as early as 1939, some 10 years before American scientists developed the same

At right, onion-shaped spires of the famed Cathedral at Zagorsk.



Mathematical problems in areas of economics and planning are solved on this BESM-2 computer.



procedures. Andrey Kolmogorov, a foremost authority on the theory of probabilities who was under constant attack by the Stalinist regime, also developed prediction formulas in the 1930s that were not uncovered in America until a decade later. This partnership of native brainpower and borrowed technology resulted in the creation of the first important Russian computer in 1955. Developed by the Institute of Precision Mechanics and Computer Technology in Moscow, the BESM-1 was completed after Stalin's death and, following the flight of Sputnik I in 1957, decisively squelched the already waning harangues on cybernetics.

By the end of the decade, the words *kibernetika* and *elektronno-vychislitel'naya mashina* became as common as vodka and borscht in the Russian vocabulary. New and improved computers were developed. Mathematicians, including the previously maligned Professor Wiener and other foreign cybernetics experts, were invited to Moscow where they received top VIP treatment. Soviet mathematicians, economists, linguists, philologists, psychologists, biologists, historians and members of the arts were encouraged to attend special international cybernetics conferences and, according to Professor Albert Parry of Colgate University, if they failed to appear, they were openly and severely chastised. Even popular humor responded to the cybernetics syndrome, with cartoons frequently appearing in Soviet publications deriding anyone who still opposed the newfound technology.

Such activity, while it helped to promote the cause of computers, did little to improve the quantity and quality of Soviet computer hardware. For example, a Minsk-22 tape unit, used extensively in many Soviet computer installations, is a low-density, low-speed system having no take-up reel. The tape from the input reel feeds directly into an open column, meaning that the operator has to make sure that (1) the tape doesn't run completely off the input reel as he has to feed the tail end into another column and (2) he doesn't get his fingers mangled in the process. Even the fastest operator cannot mount and dismount a reel in less than

three minutes. In contrast, an RCA tape deck, used for similar purposes, is a high-density, high-speed system having both input and take-up reels. Mounting and dismounting take just 15 seconds.

In fact, as late as last summer, the Russians were known to be importing advanced integrated circuitry from Western countries through Finland and other northern European nations in an effort to overcome this problem. Some Soviet scientists, recognizing the continuing difficulties in equipment production, also have begun agitating for Western assistance. Even as early as 1966, Dorodnitsyn proposed movement in this direction when he suggested in *Pravda* that the Soviets swallow their pride and start buying Western computers.

However, direct Russian purchases from computer manufacturers in the West have been sporadic at best, although, according to trade journal sources, apparently they are now increasing. To date, most Western dealings have been with the other European Communist nations.

In any case, the Russian economy — like the American free-enterprise system — will continue to be deeply intertwined with the computer. ■



BESM-6 computer performs 1-million operations a second at the Siberian branch of the Academy of Sciences of the USSR.

English-Russian dictionary is prepared via computer at the All-Union Institute of Scientific and Technical information in Moscow.

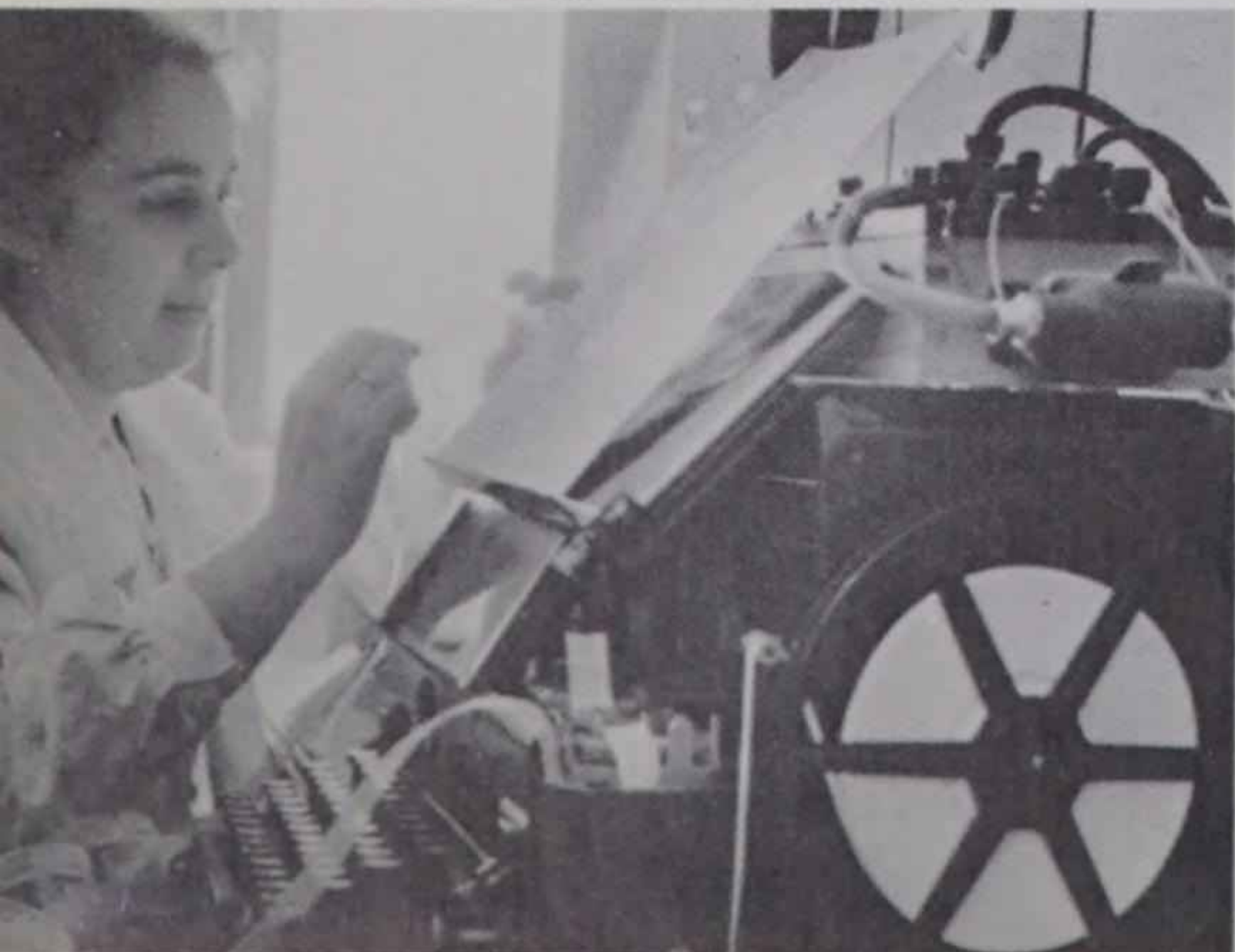

GUM, the state-owned department store on Red Square, is said to be fully computerized in the processing of sales and inventory data.

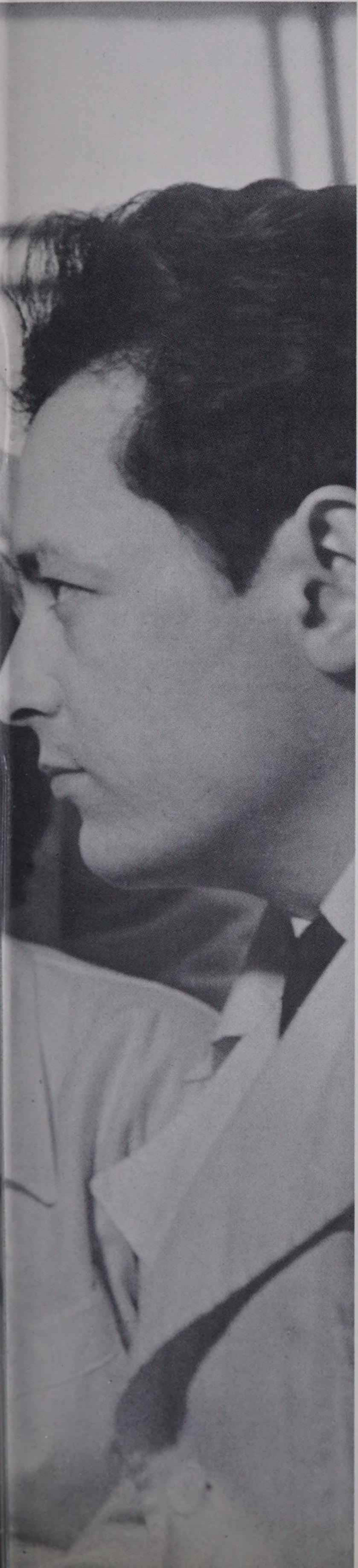

Automation makes possible the study of blood luminescence at the Novosibirsk Medical College.

The Grand Tour of the Planets

Within a decade, spacecraft will embark on flyby missions past each of the outer planets and send back close-up TV pictures of the farthest reaches of the solar system—more than 3.7-billion miles away.

by Dr. I. M. Levitt

In the closing days of the mid-twentieth century, cautious voices debated the possibility of launching satellites to orbit the earth; more adventurous ones even discussed the dream of sending men to the moon. However, as the 1950s gave way to the 1960s, theories and dreams budded into accomplishments, nurtured by a massive scientific and technological effort by government and industry that culminated in July, 1969, when astronaut Neil A. Armstrong became the first man to set foot on the surface of the moon.

But this was only the beginning of man's

conquest of space. By the end of the 1980s — just two decades away — close-up pictures of every planet in the solar system may have been seen by virtually all civilized men. And at that time, knowledge of the planets may be so comprehensive that the more provocative questions concerning life in other solar systems may rightly be posed and contemplated.

The age of direct solar system exploration began in 1962 with the success of the Mariner 2 spacecraft on its flyby mission past Venus. Since then, other flybys have photographed and taken instrument readings of both Mars and Venus.

Earlier this year, two more Mariner fly-

Dr. I. M. Levitt is Director of the Fels Planetarium in Philadelphia.

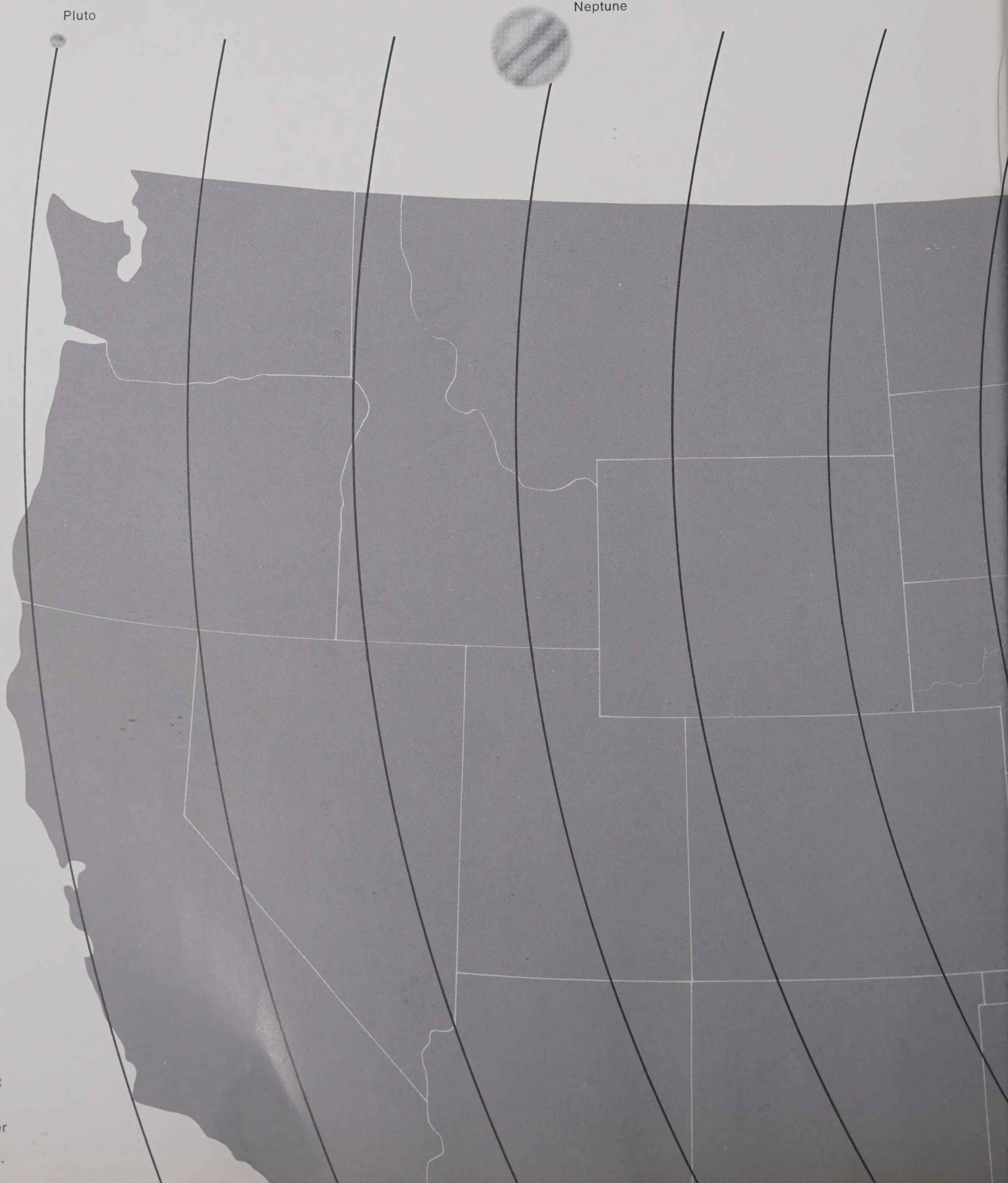

The magnitude of the "Grand Tour" of the outer planets, planned for the late 1970s, can be visualized by having the United States represent the solar system. If the sun is in New York, the orbits of all the inner planets — Mercury, Venus, Earth and Mars — would extend no farther than Philadelphia. But the orbit of Pluto, the outermost planet, would cross San Francisco.

bys were launched to Mars, and as of this writing they are right on course. In 1971, NASA plans to orbit another Mariner around Mars to relay back pictures of the surface over a longer period of time. In 1973, the Viking project may become operational, with a larger Mars spacecraft serving as a combination orbiter-lander. By soft-landing an instrument package, scientists may, for the first time, obtain definitive information on the possibility of life on the red planet.

In the same year, the first multimission flyby may be launched to Venus. After relaying information about the planet back to earth, it will be provided with a gravita-

tional impulse to head it on to Mercury where it again will perform as a flyby. In 1974, a light spidery probe may be launched to fly by the surface of Jupiter and relay both data and pictures back to earth. All of these are precursors to the "Grand Tour" in which the outer members of the solar system will be scrutinized by television cameras and sensors.

Only once in about 179 years do the precise conditions prevail to permit a spacecraft to fly by the major members of the solar system before escaping to roam endlessly through the Milky Way galaxy. The launch opportunities for this exploratory adventure will open up in 1976 and

continue each year until 1980. The initial Grand Tour concept called for a flyby of Jupiter, Saturn, Uranus and Neptune. However, scientists have recently considered breaking up the Grand Tour into two sections so that one spacecraft can also fly by Pluto — the outermost planet of the solar system. In this way, by the end of the 1980s, astronomers hope to have more complete information on all the planets.

Before the Mariner flybys, a majority of astronomers believed that they could detail most of the physical characteristics of the planets — particularly Mars and Venus — by means of available data and

educated speculation. However, as a result of information obtained by the flybys and newly developed electronic instruments, many of the basic concepts concerning the planets are being revised.

To illustrate this point, a scientist attending the meeting of the Commission of the International Astronomical Union in 1959 might have outlined his knowledge of Mercury, the planet closest to the sun, as follows:

"Measurements of the diameter of Mercury have varied from 2,700 to 3,100 miles with 3,080 miles as a consensus. The reason for this inordinately wide spread is that the planet never travels

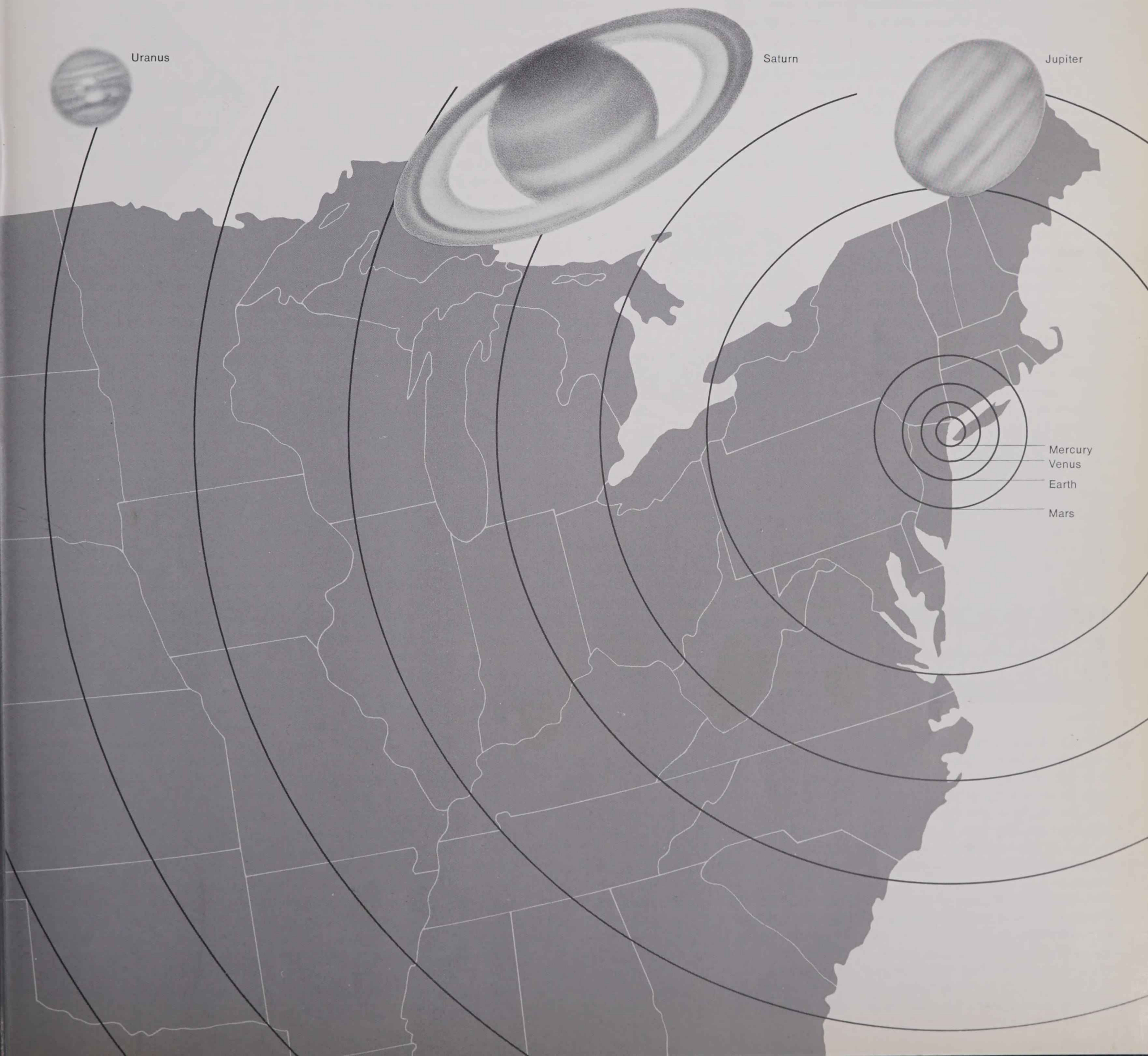

"By the end of the 1980s, close-up pictures of every planet in the solar system may have been seen by virtually all civilized men."

more than 28 degrees away from the sun, which makes it a discouragingly difficult object to observe. Because it has no satellites and its planetary perturbations are small, its mass cannot be precisely measured. As a consequence, its density is also uncertain, although some measures indicate that it may be the heaviest planet in the solar system. But with the diameter and mass uncertain, the volume and surface gravity are also question marks."

In 1959, it was believed that Mercury rotated on its axis and revolved around the sun synchronously in 88 earth days, with one side in eternal darkness and the other always facing the sun. It was believed that, on the bright side of the planet, noon temperatures were about 750° F. when the planet was closest to the sun and no higher than 530° F. at its farthest point. Temperatures on the dark side were thought to be lower than those on any other body in the solar system since its only source of heat was from distant stars and other planets.

However, radar measurements have since proved that Mercury has a rotation period of only 58.6 days, precisely two-thirds that of its revolution cycle. Apparently, for some mysterious reason, the planet is locked into a resonant period to maintain this two-to-three relationship. And the radio telescope at Parkes, New South Wales, has indicated that temperatures on the nocturnal side of Mercury, rather than approaching absolute zero, reach a balmy 60° F. Astronomers now attribute this relative warmth to a thin atmosphere.

Until 1957, scientists had believed the gravitational field of Mercury was too

**Orbit Parking
this area only**

small to hold a gaseous atmosphere on the sunward side. Now, they are certain that a thin atmosphere does exist, although its origin is still a matter of speculation. It may be that the proton bombardment from the sun is responsible for a part of this atmosphere, while cosmic rays may account for its heavier components.

Ten years ago, the planet Venus was considered in many ways to be a twin of earth, with density, mass and surface gravity only slightly less than those of man's home planet. The Venusian year was believed to be about 225 days, and the planet was thought to rotate once

every 40 days. Recent measurements with sophisticated radio equipment have determined that the planet does rotate, but, curiously, the rotation period is 247 earth days long, which means that the day is longer than the year. If there were sentient beings on Venus, they would see the sun move across the sky from west to east.

Optical telescopes have never pierced the dense cloud deck that completely shrouds the surface of the planet, but bands and other atmospheric markings have been seen on ultraviolet photographs. Carbon dioxide has been detected in this atmosphere, and astronomers believe this causes a greenhouse effect on the surface of Venus, with resulting temperatures originally thought to

**Eclipse
turn on
headlights**

be between 150° and 200° F. Subsequently, radio telescopes indicated that surface temperatures were about 550° F., and even that figure proved to be too low. According to instruments aboard Mariner 5, they exceed 900° F.

Definitive information about Venus has come from both the American Mariner and Soviet Venera flybys. The blizzards of electronic pulses relayed back by Mariner 2 indicated that Venus has neither a magnetic field nor radiation belts. The incident of meteoroids on the moonless planet has been measured at only 0.1 per cent that of the earth, showing the profound lunar effect on meteoroid showers. And the mass of Venus was determined to within 0.015 per cent.

Previously, astronomers knew that the Venusian atmosphere was dense, but not how dense. Instruments aboard the Soviet Venera 4, which landed on the surface of the planet, showed it to be 20 times heavier than that of the earth, while Mariner 5 measurements indicate that it is 75 to 100 times as dense. Another discovery made by the flybys is that the light-scattering refraction characteristics of the dense atmosphere would give a visitor to the planet a curious sensation of finding himself at the bottom of a bowl with the horizon rising instead of falling. This also may help explain why the night side of

Venus glows with a faint light. The atmosphere is so dense that it bends sunlight completely around the planet to provide some illumination on the dark side.

The most fascinating planet in the solar system is Mars. Because this planet can be seen in the midnight sky, its physical characteristics are fairly well known. For example, the rotation period of the planet is 24 hours, 37 minutes and 22.6679 seconds. This incredibly precise figure was deduced from a drawing of Mars made by the astronomer Christian Huyghens on November 28, 1659, at 7:00 P.M. in which a prominent feature was clearly shown.

Before the Mariner 4 flyby, Mars was believed to have an oxygen-free atmosphere composed primarily of nitrogen. The existence of water vapor was postulated because of the polar caps that can be seen with a large telescope. These contrasting caps are tied to the seasons, waxing and waning as each hemisphere undergoes summer and winter. The Mariner flyby verified the presence of water vapor, but measurements showed that the atmosphere is mainly carbon dioxide laced with some nitrogen and argon. The flyby also indicated that the Martian atmosphere is much less dense than was previously believed. Atmospheric pressure had been thought to measure about one pound per square inch — some 7 per cent that of earth. Now it is known to be only about 1 per cent.

The surface characteristics of Mars always have been a debatable point among astronomers, although considerable detail can be seen with an optical telescope, especially at times of favorable oppositions when Mars is only about 35-million miles from earth. Faint, evanescent straight-line markings, called canals, were discovered in 1877. Although these have been seen time and time again by some observers, other astronomers claim that on clear nights these straight-line markings disintegrate into heterogeneous markings of no significance. At one time, the canals were thought to be the product of a superior intelligence. This phase has long since passed.

Aside from the polar caps, two distinct colors can be seen on the Martian surface. One is the dull orange that provides the planet with its characteristic reddish color. The other is in the dark areas that have appeared to be green, brown or greenish brown. The darker markings seem to undergo erratic or progressive changes in some instances, and in others appear to be correlated precisely with the seasons. Evanescent markings identified as clouds of various types — some of a violent nature — persist for a short time, others for extended periods.

The most dramatic disclosure made by Mariner 4 was that the surface of Mars is pockmarked and appears much more like the moon than the earth. The 20 landscape pictures relayed to earth show craters of various sizes and shapes

**Quasars
turn down
radios**

without the straight-line canal markings. However, some astronomers still insist they see canals and oases in these photographs. From the number of depressions found on these pictures, it is indicated that there must be about 200,000 craters of all sizes on the planet.

Beyond Mars is the giant of the solar system — Jupiter. It has an equatorial diameter of about 88,000 miles and is flattened by about 10 per cent at the poles. Jupiter is completely covered by cloud belts that run parallel to the equator and continuously change in shape and form. On the cloud belts can be seen the Great Red Spot, discovered by French astronomer G. D. Cassini in 1691, which was used to determine the length of the Jovian day. Jupiter rotates once every 9 hours and 50 minutes, making it the fastest spinning planet in the solar system. The marked oblateness is a direct consequence of this rapid rotation.

The surface of Jupiter has never been seen since the cloud belts are tens of thousands of miles thick. The spectroscope reveals that the principal constituents of the clouds are methane and ammonia, and there is excellent reason to assume that both hydrogen and helium are also plentiful. There are few facts concerning the internal structure of the planet, but most astronomers assume it has a hard core surrounded by a layer of ice. Even here, there is controversy, for other astronomers believe that the solid core is composed of hydrogen in the solid phase and that the icy cover of this core does not exist because of the heat generated by the compressional forces of the dense atmosphere.

Sampling of this Jovian atmosphere at some future date may be very important. The gravitational field of Jupiter is so in-

tense that the primordial materials of which all the planets were fashioned are still present in its clouds. If some sampling mechanism could be developed, the results might lead to a better understanding of the nature of these materials. This, in turn, may provide an insight into the origin of life in the universe.

Recently, it has been thought that Jupiter may be more of a star than a planet. Measurements of infrared radiation made in 1965 showed Jupiter to be radiating about 2.5 times as much heat as it receives from the sun. The temperature on the cloud tops should be minus 270° F. but instead it measures about minus 230° F. If this excess heat does not come from the compressional forces, then it must be assumed that Jupiter is a tiny, dwarf, cold star still generating energy deep within its core.

In 1955, Jupiter was discovered to emit radio noises in random bursts that usually are indicative of phenomena like thunderstorm interference. But what is even more surprising is that these radio bursts are tied to the positions of two of the Jovian satellites.

Saturn, the last of the "naked-eye" planets, also is perpetually shrouded in clouds, but it has a ring system — a unique feature seen nowhere else in the solar system. The rings are believed to be the remains of a satellite that came too close to the planet and, owing to tidal actions, broke into myriads of tiny moonlets. The rings are 171,000 miles in diameter but less than 10 miles in depth — so thin that stars have been seen through them.

Saturn is about 75,100 miles in diameter and, like Jupiter, is strongly flattened



at the poles. Again, the reason is the rapid rotation of the planet — its days are only about 10 hours, 14 minutes in length. The Saturnian atmosphere also is composed principally of methane and ammonia, but the temperature of the clouds is so low that the ammonia is probably present in crystalline form. The planet is most likely structured with a solid core and a thick atmosphere of unknown dimension.

Beyond Saturn, knowledge of the solar system is full of gaps and, at present, the

outer planets are important only for their historical backgrounds and interest. The discovery of Uranus in 1781 by William Herschel — who originally thought the body was a comet — started a chain of events that culminated in the discovery of Pluto 149 years later. The discrepancy in the observed and computed positions of Uranus provided a clue to the presence of a trans-Uranian planet. This raw information was used later to compute the position of the disturbing planet. So precise were these computations that this new planet, Neptune, was found within one hour after the search for it began in 1846. However, the mathematical discovery of Neptune still did not account for all the discrepancies in the motion of Uranus. The search for still another planet was undertaken in 1905 by Percival Lowell and, later, by W. H. Pickering. Their computations indicated the position of a ninth planet, but the most diligent search could not uncover it. Finally, in 1930, it was discovered by Clyde W. Tombaugh in approximately the position indicated by the two astronomers. With the discovery of Pluto, it is almost certain that all the members of the solar system are now known.

However, little is known about the physical characteristics of these outer planets. Uranus and Neptune are cloud covered, with temperatures so low that ammonia is frozen and may be floating in a sea of methane. Uranus rolls around the sun like a roller bearing, for its axis is pointed only eight degrees away from the sun. If an observer on Uranus could see the sun, he would find that for 21 years it would climb in the sky until it reached its highest elevation and for the next 21 years it would drop toward the horizon. When it dropped beneath the horizon, it would remain out of the sky for 42 years, after which the cycle would begin all over again. Uranus has a system of five moons; the fifth was discovered by Gerard Kuiper in 1948.

Neptune, like Uranus, has no permanent markings, and both planets are denser than Jupiter or Saturn. As yet, however, no one has tried to fashion an interior model of either of the two planets. Neptune has a strange satellite system. Its larger moon moves in a circular retrograde orbit while the other possesses the most eccentric orbit of any satellite in the solar system. Pluto once may have been a satellite belonging to Neptune that for some unknown reason escaped that planet's gravitational bonds. The fact that the orbit of Pluto is so eccentric as to approach closer to the sun at its perihelion than does Neptune argues strongly for this case.

Object	Mean Distance From Sun (Millions of Miles)	Year (In Terms of Earth Years)	Mean Orbital Speed (Miles Per Second)	Inclination To Ecliptic (Degrees)	Equatorial Diameter (Miles)	Volume Earth=1	Mass Earth=1	Density Water=1	Surface Gravity Earth=1	Moons	Equatorial Axial Rotation (Day-Hour-Minute)
Mercury	36	0.24	29.8	7.0	3,010	0.055	0.053	5.3	0.37	0	58.6d
Venus	67	0.615	21.8	3.4	7,700	0.91	0.815	4.95	0.87	0	243.2d
Earth	93	1.00	18.5	0.0	7,927	1.00	1.000	5.52	1.0	1	23h 56.1m
Mars	142	1.881	15.0	1.9	4,200	0.15	0.107	3.95	0.38	2	24h 37.4m
Jupiter	484	11.86	8.1	1.3	88,800	1317	318	1.33	2.64	12	9h 50.5m
Saturn	887	29.46	6.0	2.5	75,100	762	95.22	0.69	1.14	10	10h 14m
Uranus	1785	84.02	4.2	0.8	29,600	50	14.55	1.56	0.96	5	10h 49m
Neptune	2797	164.78	3.4	1.8	27,700	40	17.23	2.27	1.53	2	15h 40m
Pluto	3670	248.4	2.9	17.1	3,600(?)	0.09(?)	0.9(?)	(?)	0.82(?)	0	6.4d
Sun	864,400	1,300,000	333,400	1.41	27.9	..	24d 16h
Moon	Distance From Earth—238,857 mi	Month 29d 12h 44m 2.8s	2287 mph	5° 9'	2,160	0.0204	1/81	3.34	0.165	..	27d 7.7h

Pluto represents an enigma in the solar system. By its perturbative effects on Neptune, its mass is computed to be about 0.9 times that of the earth. Its diameter is about 3,600 miles, according to measurements made by Kuiper with the 200-inch Hale telescope. If the mass and diameter are accurate, then the density of the planet is somewhere between 30 and 50 times heavier than water, which is impossible, since according to known science, the heaviest element in the universe is osmium with a density of about 22.5. Obviously, something is wrong, but the error has not been pinpointed.

Pluto is so distant from the sun that any ammonia or methane, once part of its atmosphere, has been frozen out and lies on the surface as a sheet of ammonia or methane ice. It may have an atmosphere of hydrogen, helium or neon, but it is impossible to verify this from earth. Only a flyby, such as the Grand Tour, can provide any answers to questions involving its physical characteristics.

Beyond the planets are comets that are believed to lie dormant out in interstellar space, perhaps two or three light-years from the sun. They visit the sun only when disturbed by the gravitational field of a passing star. It is the filmy substance of these comets that gives rise to tiny meteors occasionally seen during the night. As the comets move toward the sun, they are attracted by gravitational forces of the planets, subjected to the tidal action of the sun and affected by solar radiations. As a result, they disintegrate after, perhaps, 100 trips around the sun. This disintegration is one of the sources of the meteoroids in space.

There is one other source of meteoroids — the asteroids. These are believed to be the remains of a planet that once

circled the sun between Mars and Jupiter and are the cosmic debris responsible for the craters on the moon, Mars and, occasionally, earth. Venus and Mercury also may have been bombarded by asteroids that created craters on their surfaces. Perhaps this is another bit of information that will evolve from the exploration of the inner planets.



This account of the decade of interplanetary exploration that may culminate in the Grand Tour of the outer planets covers mostly the efforts of this country. The Soviet Union may well have matched America's planetary efforts, although with less publicized success. But, because of the lack of information on their intent in the planetary field, no one aside from Russian space scientists is qualified to assess their efforts.

Achievements in space have been multiplying while the time needed for their fruition is continuously being compressed. If the Grand Tour is successful, the technology of man will have moved, in less than a single century, from primitive powered flight, a few dozen feet above the earth, to the very limits of the solar system.

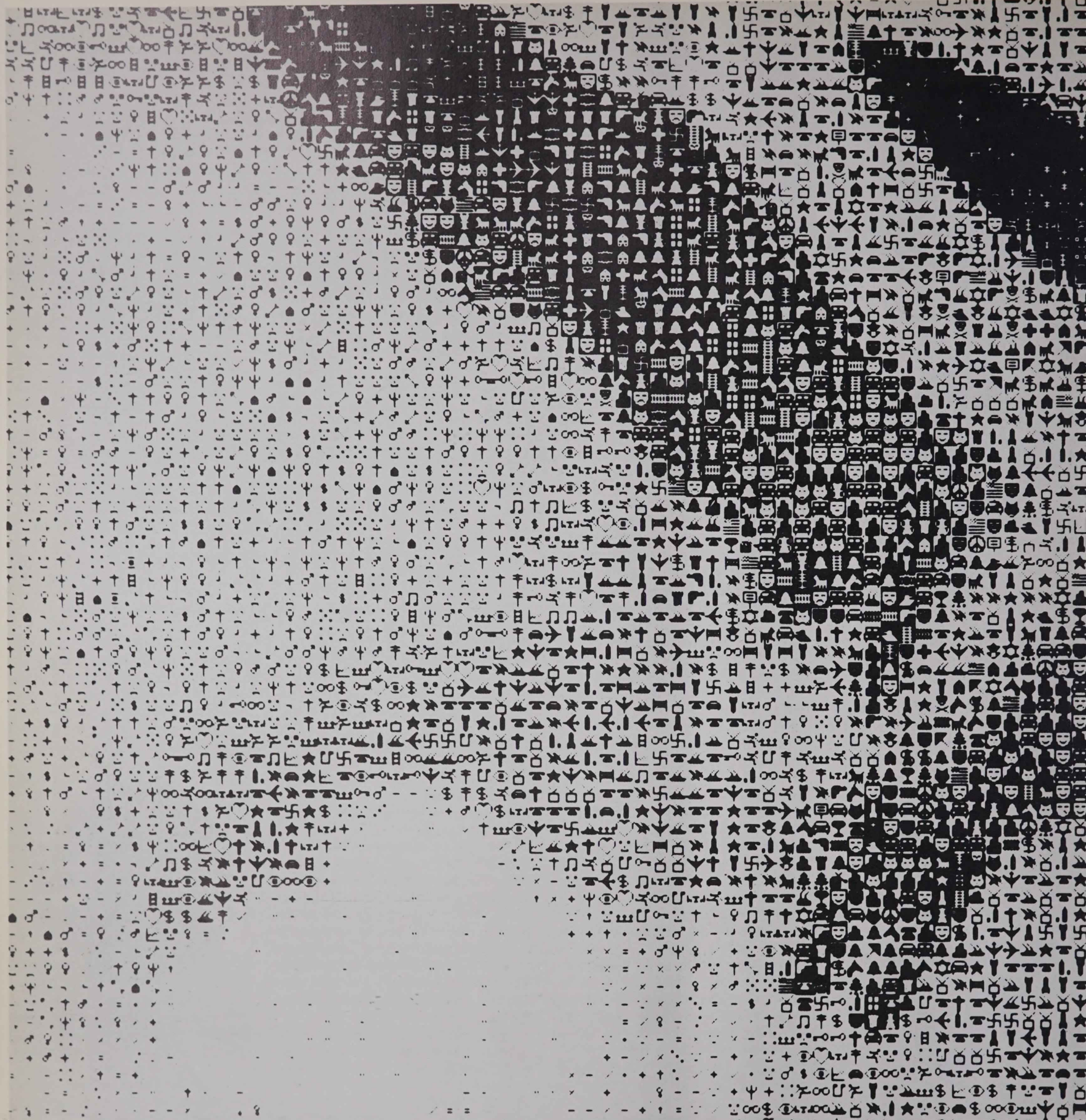

Art and the Computer

The modern artist is now experimenting with the ultimate mathematical tool.

by Tom Shachtman

Today, computers are helping artists to create new and intricate works of art, many of which have received wide critical acceptance. Some critics view these works as logical developments in the history of art, citing the artist's traditional concern throughout the ages for mathematics — the focal point of computer art.

The Greeks were aware of mathematical perfection in nature and believed that great creations could be described by mathematics, even if the formulas were

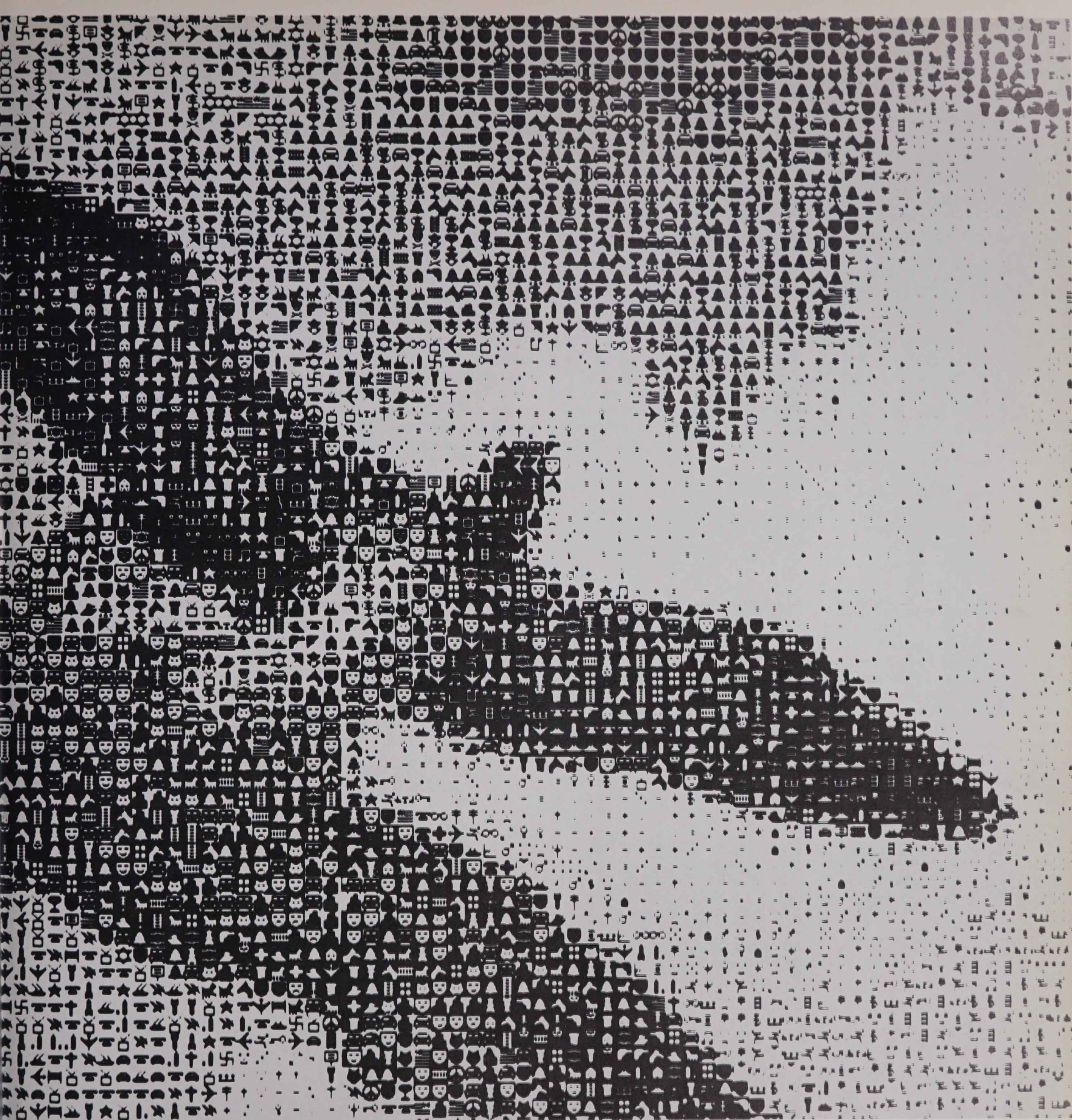

Gulls: Studies in Perception II by K. C. Knowlton and Leon D. Harmon. This computer-generated picture is made up of 11,616 tiny, familiar objects (bottom). At close range, these objects are clearly visible, but the large picture of the seagulls cannot be perceived. When the viewer moves away, the small details fuse together and the over-all picture takes on the quality of a continuous-tone photograph.

Tom Shachtman has written extensively on both cultural and scientific subjects.

beyond their comprehension. However, the first treatises on mathematics and art were products of the Renaissance. Writers of that period discussed the importance of relative proportions in art, and artists tried to make their works conform to these descriptions. There were mathematically described relationships between the size of the torso, legs, head and arms and also among the various aspects of a painting such as the background, foreground and subject. It was

known that certain repetitions within a painting produced generally pleasing effects. A line formed by the subject's arm might well be repeated in the curve of draperies or clothing, then show up again to good effect in the background scenery. Today, repetition and proportion are two of the tools of computer art. Renaissance artists observed that the proportions for head to torso, legs to torso, or from any part of the body to another part changed when viewed from

different angles. They recognized that reality and appearance were different and had to be painted differently, and developed techniques of foreshortening to give art the illusion of reality. Previously, art was representational. A painting depicted a girl with both arms in front of her in an anatomically impossible position, and convention helped the viewers know what was meant. With foreshortening and its outgrowth — perspective — paintings began to look more realistic. Perspective is essentially geometric: it is the way any object appears from a given point.

These developments were refined and continued through the latter half of the nineteenth century when Impressionism, a new, semimathematical development, took hold. The Impressionists noticed that points in space differed radically in the subjective eye of the artist, and they incorporated this phenomenon in their paintings. There were separate representations on the canvas for each point that they considered distinct. Thus, Impressionist paintings often reveal scenes of multitudinous colors that may either melt into one another and give one harmonious impression, or appear uniquely separate, depending on the perception of the viewer and his distance from the work. This use of substitution reached its apex in the pointillist art of Seurat, whose paintings are made up of thousands of tiny dots that blend into a whole when viewed at a distance.

Substitution is also a major component of computer art and is quite mathematical in its precision and its technique. This

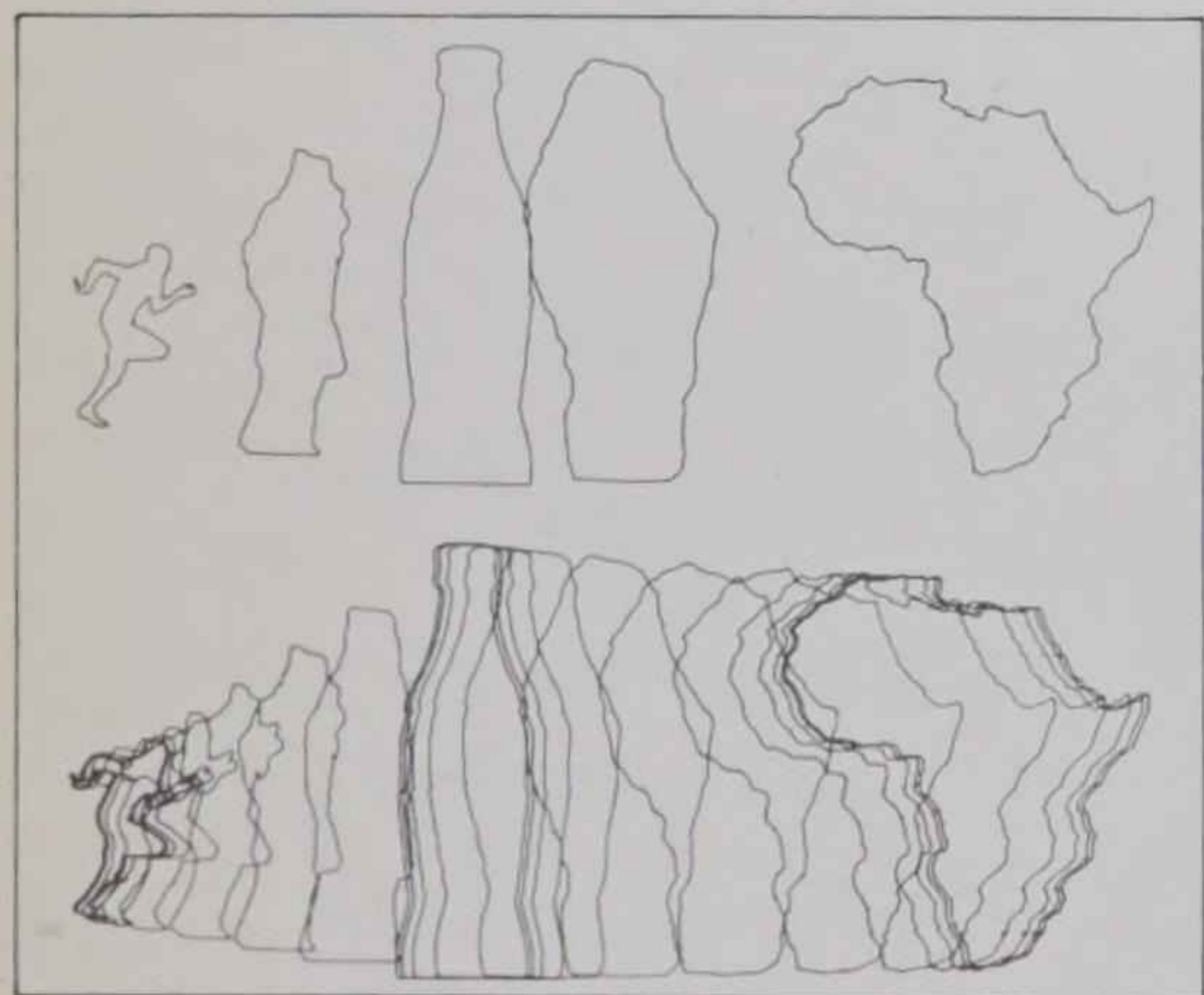

Running Cola Is Africa by Masao Komura, Koji Fujino and Makoto Ohtake. A computer algorithm converts a line drawing of a running man into a bottle of cola. This, in turn, is transformed into a map of Africa.

use of optical illusion is basic to op art, which computer art sometimes resembles. Both depend on the cumulative effect of several points on the eye and the visual impression received in the mind.

The twentieth-century development that presaged computer art was the work of the Futurists, a group of Italian and French artists who were obsessed with machines and the idea of introducing motion onto the still canvas. They experimented with repetition, permutation and substitution, and their paintings give impressions of fluidity and excitement, just as does the best computer art.

Marcel Duchamp, a leading figure of modern art, studied the treatises of French mathematician Jules Henri Poincaré as an aid to constructing optical illusions in his art. At about the same time, the faculty and students of the German Bauhaus school also were concerning themselves with mathematics. Artists Klee, Kandinsky, Feininger and Moholy-Nagy as well as architects Gropius and Miës van der Rohe all used mathematical relationships in their work. Feininger's subjects, for example, have cubical and trapezoidal shapes that ascend into the architectonic space above and about them — they exist only in a mathematical world. *Study for "The Triadic Ballet,"* by Oskar Schlemmer of the Bauhaus, shows ellipsoids and hyperbolic shapes for torsos and limbs and perfect spheroids for heads. The beauty of the shapes is almost totally dependent on their geometric perfection.

Mathematics continues to be important to the modern painter, and he is depending more and more on the ultimate mathematical tool. A computer, for example, can take a mathematically described figure and repeat it endlessly

with much greater precision than a human hand can do. Through the simple addition of an equation to an already existing program, the computer can distort or permute a figure as well as repeat a pattern with slight permutations randomly about a prescribed area. Guided by a relatively simple program, it can substitute one figure for another or produce a complicated figure for each point on a line. In addition, a computer can expand, contract, reshape, multiply or transform a figure or a series of lines. Various combinations of all these functions are at the heart of all computer art.

For example, Ken Knowlton and Leon

glyphs are seen separately; held at arm's length, a whole painting is perceived. This is simple substitution. More complicated are the works of programmer John Mott-Smith of the Air Force Cambridge Research Laboratories. He works, as most computer artists do, by producing mathematical designs on a cathode-ray tube and modifying them with a light pen. Mott-Smith's works stress duplication — a figure is repeated many times, then another figure is superimposed on it and another on that.

A group of Japanese programmers is using other techniques. In one recent show, they exhibited two dozen different

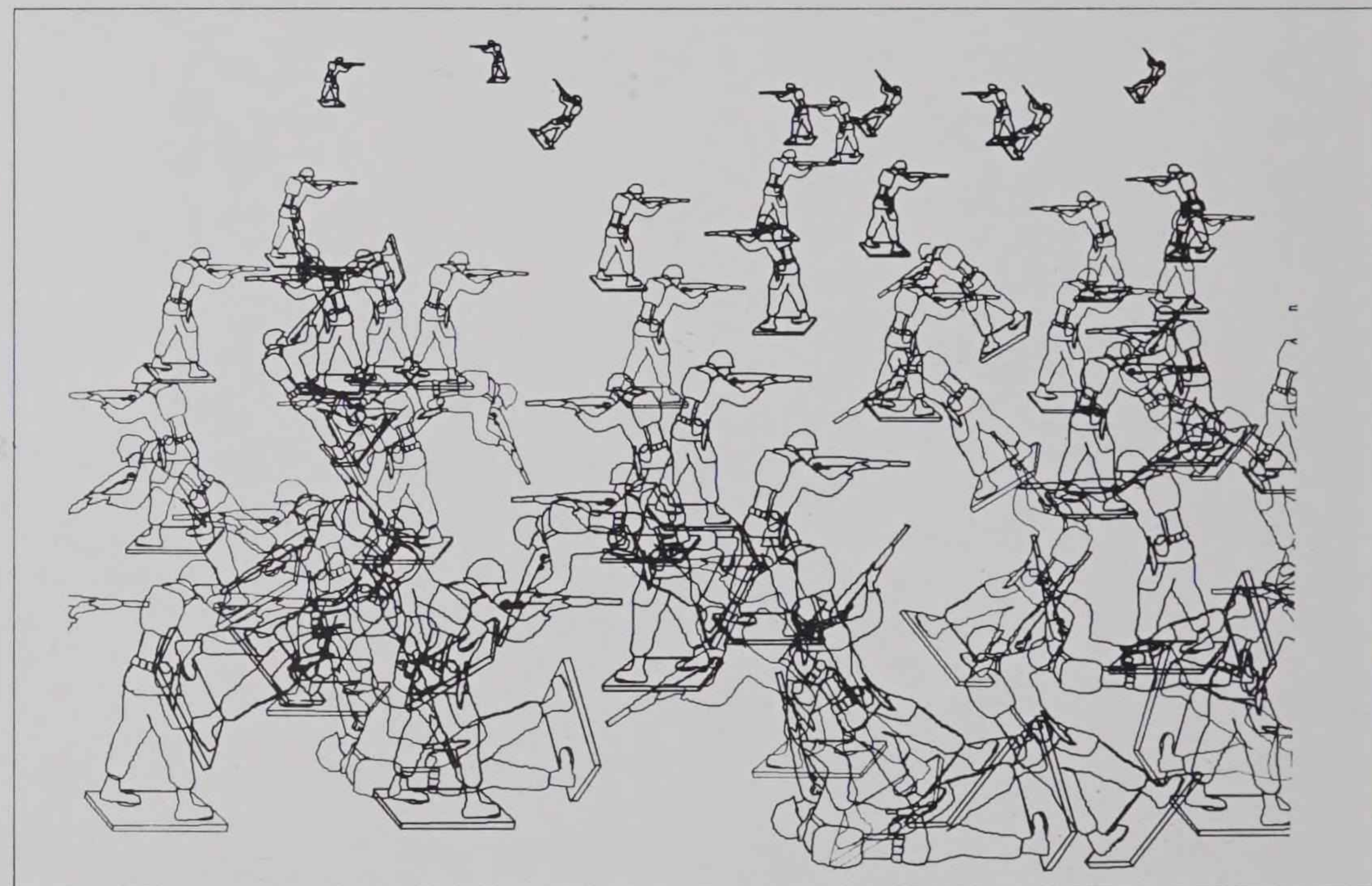

Random War by Charles Csurí. A drawing of a toy soldier repeated in endless variation eventually resembles a battlefield. A computer program controls the battle.

Harmon of Bell Laboratories take conventional photographs and scan them electronically until they are broken down into 14 different shades of gray, white and black. For each shade, they program the computer to substitute tiny hieroglyphic symbols — faces, airplanes, animals, musical notes, telephones and automobiles. The effect is not unlike a Seurat painting: held close up, the hiero-

glyphs are seen separately; held at arm's length, a whole painting is perceived. This is simple substitution. More complicated are the works of programmer John Mott-Smith of the Air Force Cambridge Research Laboratories. He works, as most computer artists do, by producing mathematical designs on a cathode-ray tube and modifying them with a light pen. Mott-Smith's works stress duplication — a figure is repeated many times, then another figure is superimposed on it and another on that.

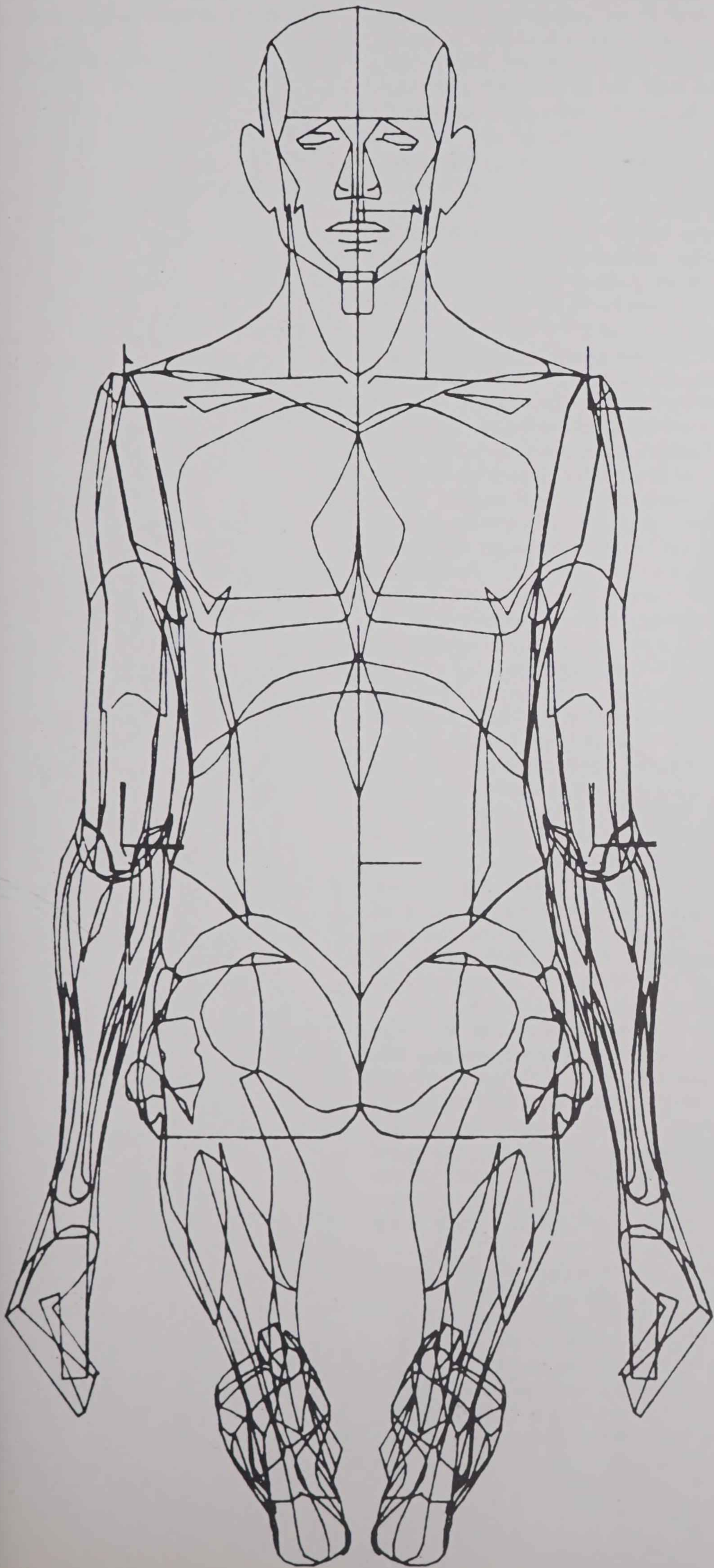

sinister impact on the left ear. Another shows him diffused, as if seen under water. The techniques used are deformations, metamorphoses or variations on a cubic pattern.

A second unusual effort by this group is called *Running Cola Is Africa*, in which a computer algorithm converts a line drawing of a running man into a bottle of cola. This, in turn, is converted into a map of Africa. One of the artists explains: "Computer art says something about time, space and existence. An object in space is transformed via magnetic tape into a set of units of information, or bits, conveyed throughout via two simple statements, 1 or 0."

Cyberneticist-artist Frieder Nake of the computer institute of the Stuttgart (Germany) *Technischehochschule* writes that the use of random patterns is "peculiarly suited to a computer's patience. An analogy may be drawn here to the artistic process of pursuing a theme through all of its possibilities, guided by intuition. Here, the concept of intuition refers to the choosing of possibilities from a given repertoire. The computer simulates intuition by the automatic selection of pseudorandom numbers."

Charles Csuri is an American artist who has used computers as a means of extending his art. For example, in his work *Random War*, he made a drawing of a toy soldier with a rifle aimed and about to fire, which was repeated in endless variations as dictated by the computer until it resembled a battlefield. A program that generated random numbers determined the distribution, rank and positioning of soldiers on the battlefield, and finally decided which of them should die (lying-down position), which should be wounded (half-down position) and which should survive (upright posi-

tion). Csuri points out that the computer also could introduce such variables as terrain features, physical condition of the troops, weather factors and intelligence into the final print if he wished the program to be more sophisticated. Csuri also has weighed the possibilities of using the computer to obtain precise art effects. For example, a computer might transform a drawing of a head with uneven eyes so it looks anatomically right and then store the mathematical de-

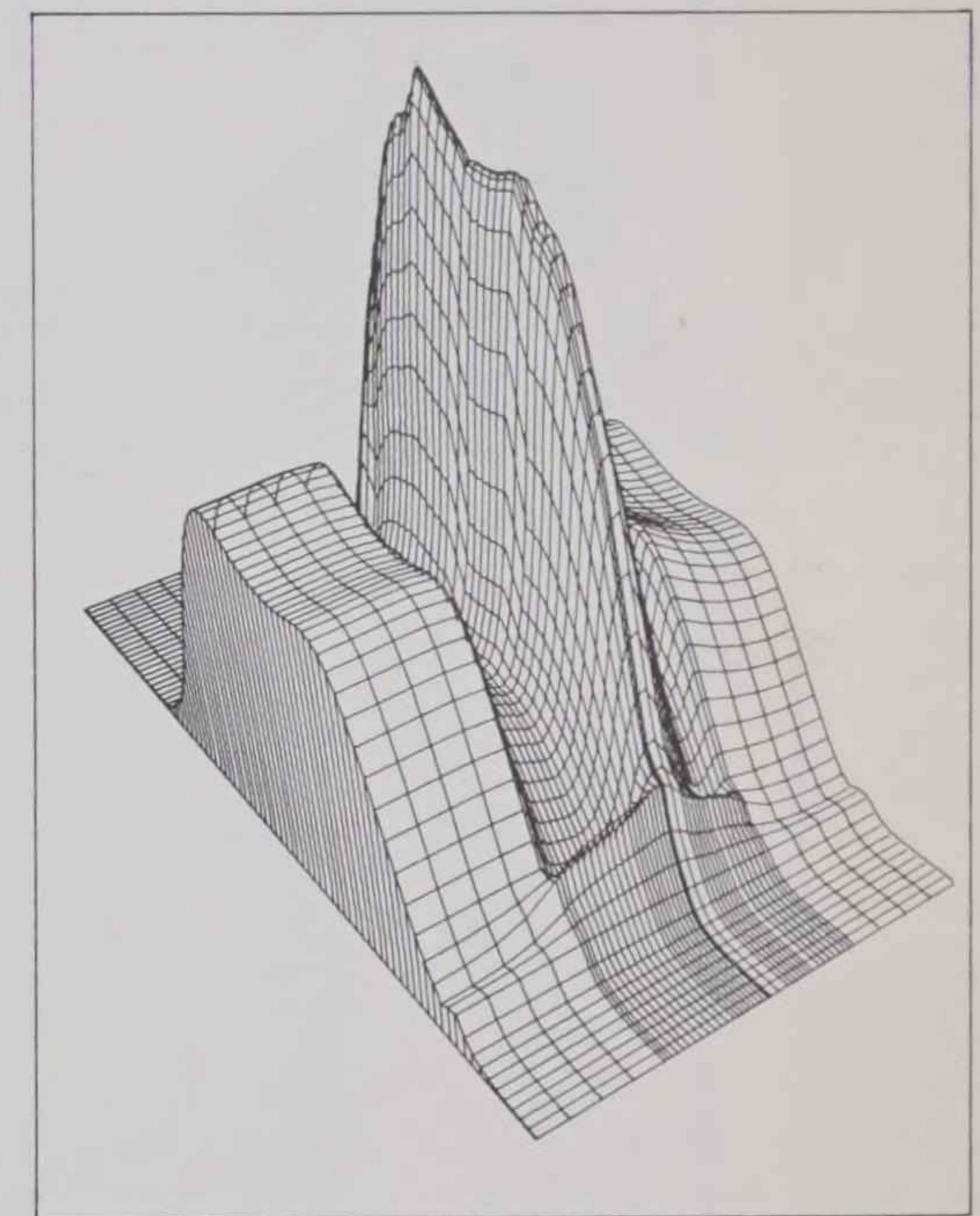

Perspective view of neutron distribution in an atomic reactor as generated by a computer.

scription of those eyes in its memory for future use.

Another variation — often the most beautiful type of computer art — is endless repetition of mathematically perfect or mathematically graceful forms, rotated slightly about an axis to produce deli-

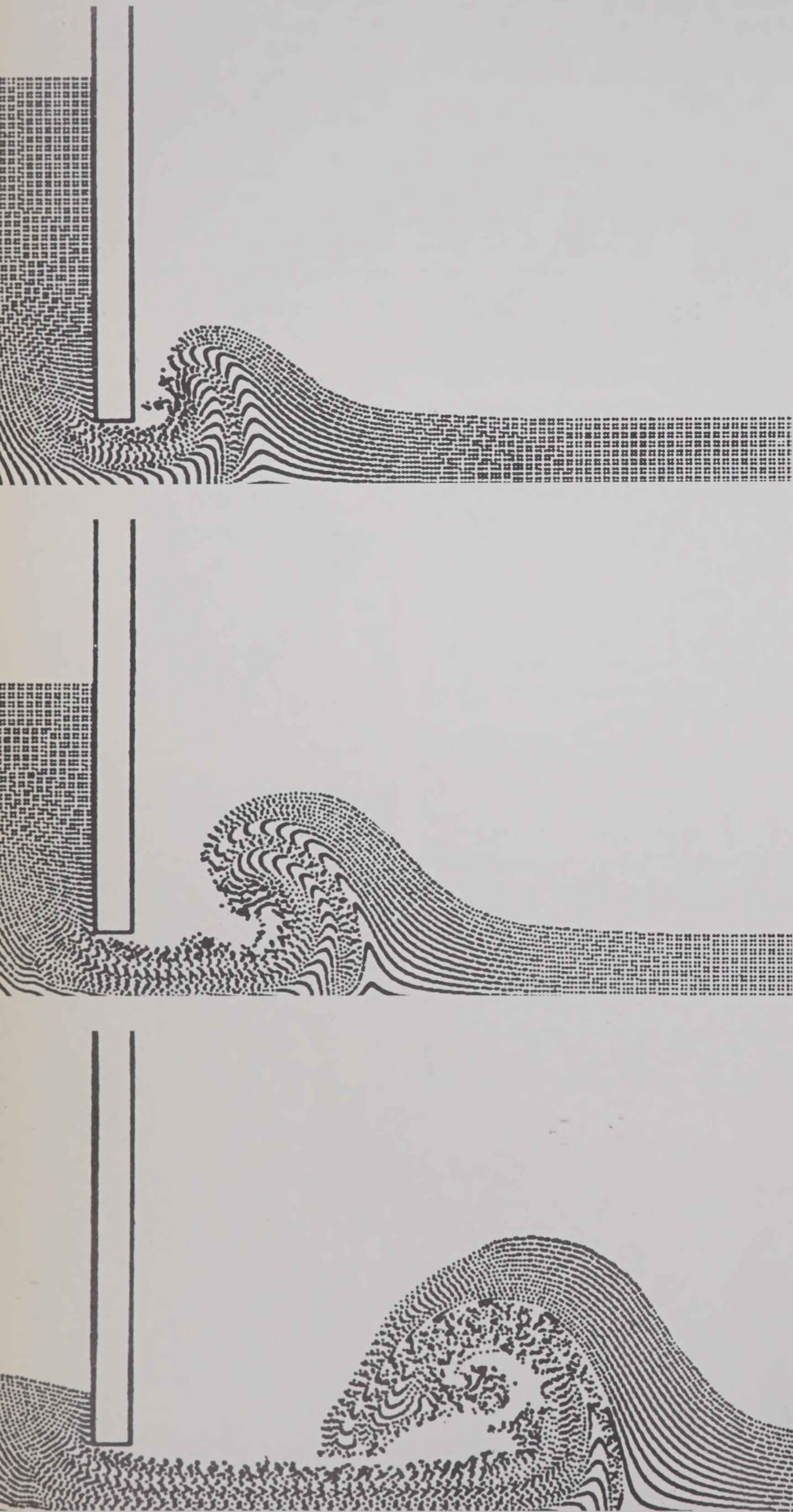

Frames of a computer-produced film depict the escape of water under a gate.

cate, appealing abstractions. Engineers at such diverse places as the University of Virginia, Carnegie-Mellon University, the Naval Ordnance Test Station at China Lake, Calif., McGill University and Princeton University have all experimented with such variations. Sometimes, the most startling results happen by serendipity, as in *Ellipse by Error*, a work produced by two engineers at the Sandia Corporation. One of them explains: "This elliptical figure was accidentally generated during a study of digitally generated Lissajous figures. The figure should have been an ellipse caused by a 45-degree phase shift, with sample points every 0.1 inches along the boundary of the figure." Such mathematical descriptions may be a part of art catalogs of the future.

Even though computer art is now widespread, the creation of such art generally has been confined, until recently, to engineers and scientists familiar enough with EDP to take advantage of the machine's artistic capabilities. Now, artists are becoming more interested in using computers, and some engineers are attempting to help them by designing programming languages that they can use effectively. Ken Knowlton puts it this way: "The problem of providing an artist with good software involves the search for a comfortable compromise between the extremes of machine autonomy and machine stupidity. In the first case, we have a machine that works almost entirely automatically, producing great volumes of output over which the artist has little control except for culling the results. At the other extreme, the programmer has complete spot-by-spot control, but far too much effort is required for specifying an interesting picture... The outcome of present experimentation ultimately may be a number of relatively suitable languages for artists. Such languages may become sufficiently established and familiar — no longer a cute gimmick — that artists can use them to say something without the medium itself arousing such curiosity, acclaim or disdain as to distract severely from the artistic content of the work."

Although computers alone will probably never produce great works of art, they are becoming an increasingly important catalytic tool of the artist in producing beautiful things. For, as Professor Norbert Wiener of MIT said: "The art of invention is conditioned by the existing means." And the computer is extending those means. ■

The Best-Seller Phenomenon

From *Tarzan* to Dr. Spock's *Baby and Child Care*, best-seller lists have reflected and, at the same time, influenced the book-buying habits of the American public.

by Roger Smith

Pollyanna, Tarzan, Rhett Butler, Will Stockdale and Alexander Portnoy all have at least one thing in common: they have been on best-seller lists. Miss Goody-Goody of the not-so-golden West, the creation of Eleanor H. Porter, made her first appearance in 1913, sold over a million copies and added the word "pollyanna" and its variants to the dictionary. The following year, the crown prince of the jungle, with a boost from Edgar Rice Burroughs, swung out of his tree and onto the best-seller charts. *Gone With the Wind*, the Civil War classic by Margaret Mitchell, came out in June, 1936, and in six months sold a million copies. Private Stockdale, the amiable country boy in the Air Force and the wide-eyed nemesis of military authority, was the hero of Mac Hyman's *No Time for Sergeants* (1954), which went on to bestsellerdom, the stage and films and still graces the TV tube today. And Philip Roth's Portnoy, the champion victim of mother love in American literature, has been a familiar figure to readers since early last spring.

What a best-seller list represents is the sale of adult trade books — divided into

Roger Smith is Executive Editor of *Publishers' Weekly*.

fiction and nonfiction — through bookstores. There are at least four recognized national lists: the *New York Times Book Review*, *Time* magazine, *Book World* (the Sunday literary supplement of the *Washington Post* and the *Chicago Tribune*) and *Publishers' Weekly*, an industry trade journal. The *PW* list, for example, is based on a national sampling of 75 to 80 stores, weighted according to their dollar volume and supplemented by local best-seller reports from newspapers around the country. Most of the latter are drawn from sales reported by local bookstores, while

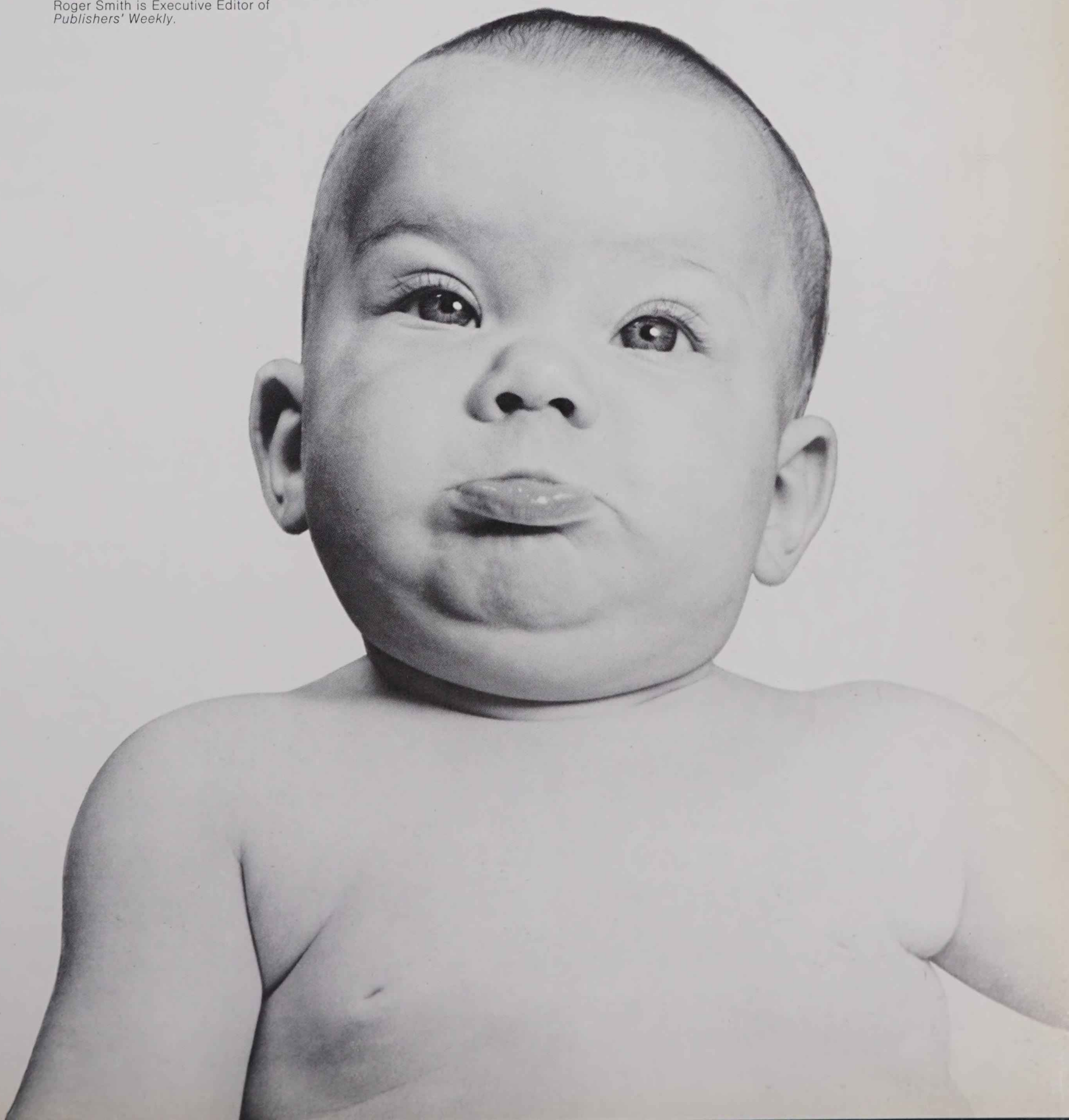

some also rely on public library circulation figures. There are often some variations among the national lists, but, since they all poll essentially the same group of booksellers, they are in general agreement as to what the nation is reading at any given moment.

The bookseller is at once the key to the best-seller phenomenon and the root of its fallibility. Each bookseller has his own method of keeping track of sales, his own regional interest and pressures, and his own motives. The compilation of

a best-seller list is still an inexact art based on subjective criteria.

Typically, a best-seller list does not include what is generally agreed to be the all-time No. 1 seller — the Bible — although a new edition, such as the Revised Standard Version, in the 1950s, is likely to be listed. Also excluded are mail order how-to-do-it books, technical manuals, sex books, and encyclopedias — the book industry's big-ticket items — most of which are sold door-to-door. The lists also ignore textbooks, some of which are



Among the biggest all-time best sellers. Children's books and paperbacks are also left out, though these categories sometimes have best-seller lists of their own.

Despite these restrictions, best-seller lists have been around for nearly three-quarters of a century. According to Dr. Frank Luther Mott, the historian of best-sellerdom and the author of *Golden Multitudes* (1947, reprinted 1961), the first best-seller list appeared in the *Bookman* in 1895. This trade journal reported "books in demand" in various cities and,

like the lists that have been developed since, reflected a national consensus although it was hit-or-miss statistically. It made no distinction between fiction and nonfiction, although 90 per cent of the titles regularly listed were novels. *Publishers' Weekly* took over the quasi-official role of best-seller auditor in 1911, originally on an annual basis, later on a monthly basis, and, in 1932, on a weekly basis. In the late 1920s and early 1930s, a number of newspapers — regional as well as national — began publishing their own best-



seller lists. The New York *Herald-Tribune* was one of the first to do so.

The best-seller lists appearing in the press are based on rate of sale. A book becomes a best seller by moving faster than other books at a particular time, but the rankings do not necessarily reflect total sales. On a recent *PW* list, for example, Haim Ginott's *Between Parent and Child* was No. 2 and *The Money Game* was No. 1. But the Ginott book, though older, had racked up a total sale of 455,000 copies, while there were 245,000 copies of *The Money Game* in print. To get the total picture, *PW* compiles a list of each year's best sellers.

Mott, as a result of his survey going back to colonial times, concluded that a book is a best seller if its sales meet or exceed 1 per cent of the nation's population in the decade of its publication. Even this formula is not wholly satisfactory since a book can have a marketing life-span of more than 10 years.

Since the retail book trade is not immune to seasonal pressures, the time of year has a lot to do with whether a book makes a best-seller list. A lower rate of sale is required to make the lists during the "dog days" of August than in the frantic pre-Christmas season. But since, in theory, the book business is uniformly anesthetized in August and lively in December, the lists stay relatively in balance.

Can a publisher spot a best seller in advance? This question has been bandied about at countless book trade bull sessions, and the conclusions are always inconclusive. (The classic "can't miss" imaginary title is *Lincoln's Doctor's Dog*.) Publishers can be guided by subjects that have done well in the past. They also warily contemplate current fads. Book publishing as it is commonly practiced is not speedy, and, by the time a fad book is published, the craze may be dead. And the fact that one book on a particular subject has been a great success is no guarantee that another will succeed; more likely, the second book will flop. The public interest in archaeology after the publication of C. W. Ceram's *Gods, Graves and Scholars* proved deep enough to support many popular books on that subject. However, the interest in reincarnation, in the wake of *Bridey Murphy*, caved in on the also-rans.

Because of the element of timeliness, many of yesterday's best sellers are now forgotten and out of print, while many of the books that have survived were not contemporary best sellers. For example, *The Great Gatsby* by F. Scott Fitzgerald never made the 1925 honor roll. Best-seller lists record not the books that people should have bought because of their

merit but the books they did buy.

If a book lacks charisma, there is little a publisher can do to make it a best seller. But if the publisher thinks a book has the undefinable "it," he has a considerable number of avenues open to him to create the all-important word-of-mouth interest that spurs sales.

Before publication, he can take splashy ads in the trade press and talk up the book to literary agents, columnists and trade press journalists. He can give away complimentary advance copies to influential VIPs. He can selectively place first-serial rights with magazines. (Months before *Portnoy's Complaint* was published by Random House, literary opinion-makers were reading excerpts in *Esquire* and the *New American Review*, two influential publications.) He may plan an extensive consumer advertising campaign for the book and newspaper-radio-TV publicity exposure for the author and finally throw a big party on publication day.

When the potential best seller is published, it gets a first-rate production job, a generous first printing and an eye-catching dust jacket, which is its point-of-sale poster, and then the publisher sits back and waits, hoping he has done all the right things.

Or the publisher can do none of these things. Instead, he can dribble the book out in a small printing with an undistinguished jacket and no ads and wait for word of mouth to come to him. Sometimes, lightning does strike. It struck *Bridey Murphy*. And more recently, it struck an esoteric book by a California psychiatrist published in 1964 in a small first printing. A year later, on beaches from Truro to Amagansett, people were talking about the book, and Eric Berne's *Games People Play* came to be the No. 3 best seller of 1967, selling 625,000 copies over a three-year period.

In any case, a best seller must have momentum, since it is dependent on rate of sale. A book must push its way onto a best-seller list. Once there, it may hang on for a few weeks and then drop off. Or it may accelerate in its rate of sale, simply by virtue of being on the list. The book trade recognizes this possibility of acceleration and uses extra vigilance in re-ordering books that are currently "hot." For a bookseller, if there is anything worse than being stuck with many copies of a book that has stopped selling, it is being caught out of stock on a title that everyone suddenly wants to read.

Best-seller lists serve the publisher and general public in addition to the retailer. They are invaluable promotion tools for authors and publishers — at least for those authors and publishers who are on the

lists. Advertisements and press handouts can cite the authority of the *Times* or *PW* in advancing the claim that a book is a top seller. Because newspapers and magazines run these lists as a matter of legitimate news, they are imbued with a certain objectivity and make it unnecessary for a reader to accept a book's status purely on the publisher's say-so.

A few months ago, readers of the book-news columns noticed a dual series of large-space ads by two publishers, each proclaiming that his book was No. 1 in fiction. Each was, at that moment, indeed No. 1, though not on the same list. This did create conversation and controversy, and it did generate sales. A static best-seller list, with the same titles in the same positions week after week, has a depressing effect on the bookstores. An actively changing list, with several titles jockeying for position, makes bells ring on bookstore cash registers. The best-seller phenomenon entices people to buy books that they might otherwise ignore. Likely as not, they may even be good books.

Critics of the best-seller system have charged that it promotes social conformity by sending people, sheeplike, after books that "everyone else" is reading. However, looking back at the history of best sellers, it is equally possible to conclude that they mirror contemporary society. From his vantage point in 1947, Mott found the more common denominators of America's best sellers to be religion, self-improvement, sensationalism, sex, personal adventure and exotic locales. Good or bad writing, he concluded, has very little to do with the success of any book.

However, nonfiction volumes consistently outsell fiction. For example, in an average spring week, a novel will become a candidate for the best-seller list if it is selling at the rate of 1,000 copies a week. On the other hand, a nonfiction book must move three times as fast in order to qualify. To illustrate this point in total sales terms, the No. 10 fiction best seller of last year, Morris West's *The Tower of Babel*, made the annual honors chart with a sale of only 68,000 copies, while Desmond Morris' *The Naked Ape* missed the top 10 despite a 177,000 sales figure. During the past decade, yearly sales of the No. 1 fiction best seller have ranged from 170,000 to 400,000 copies. (*Doctor Zhivago* by Boris Pasternak was the exception, with a half-million copies.) Annual sales of the top nonfiction book ran the gamut from 250,000 to 825,000 copies. (The exception was *Four Days*, a memorial volume about the John F. Kennedy assassination prepared by American Heritage and United Press International,

which sold 2.5-million copies.)

This has not always been true. During the early years of America, nonfiction, especially with a religious and a didactic bent, dominated bestsellerdom. From pre-Civil War times to the 1930s, fiction was king. With the 1950s, the pendulum swung back to nonfiction. Alice Hackett — called the statistician of best sellers — notes that, in the last decade, the nonfiction best sellers have outsold fiction by better than a two-to-one margin. This shift started in the religious field with such books as *The Power of Positive Thinking* by the Reverend Norman Vincent Peale but of late has come to encompass such weighty authors as educator James B. Conant, economist J. Kenneth Galbraith, journalists Harrison Salisbury and Arthur Krock, and historian William Manchester. This would seem to indicate a more serious, better educated and affluent audience for the trade book.

Today's readers are buying books about recent history and current events such as *The 900 Days* by Salisbury, *The Arms of Krupp* by Manchester, *The Tragedy of Lyndon Johnson* by Eric F. Goldman and *Thirteen Days* by Robert F. Kennedy. In addition, physical fitness, a hardy perennial in bestsellerdom, is represented by *Miss Craig's 21-Day Shape-Up Program for Men & Women*. Anyone familiar with the autumnal TV viewing habits of the American male will not be surprised to find pro football present and accounted for in *Instant Replay* by Jerry Kramer of the Green Bay Packers.

This is a varied but not frivolous list. It is more serious than, say, that of 10 years ago, when books offering counseling to teen-agers, cracker-barrel humor and medical advice topped the best-seller list.

The 1969 crop of best sellers seems to have greater social significance, although it is certainly not stuffy. If best sellers do mirror the society they come from, iconoclasm currently is riding high — a statement that would not surprise any campus activist. *Portnoy's Complaint*, for example, in the process of revising all publishing mores, has elevated offbeat sex to literary heights. And a recent nonfiction best seller was *The Money Game* by the pseudonymous Adam Smith, which takes an unusual look at Wall Street.

Do these two books add up to a representative current view of society? Maybe, but there is the fact that the all-time best seller in America is Dr. Spock's *Baby and Child Care* (20-million copies). ■



Romantic Arias
Placido Domingo, tenor
Edward Downes conducting the Royal Philharmonic Orchestra LSC-3083

In his first Red Seal recording, Placido Domingo sings 10 tenor arias that not only span more than 100 years of opera but also display the essential romanticism of the art. The 28-year-old Domingo made his debut in Mexico with the National Opera when he was only 20. In 1968, with only 35-minutes' notice, he made his debut at the Metropolitan Opera by replacing the ailing Franco Corelli in *Adriana Lecouvreur*. His performance received unanimous acclaim from critics and public alike.

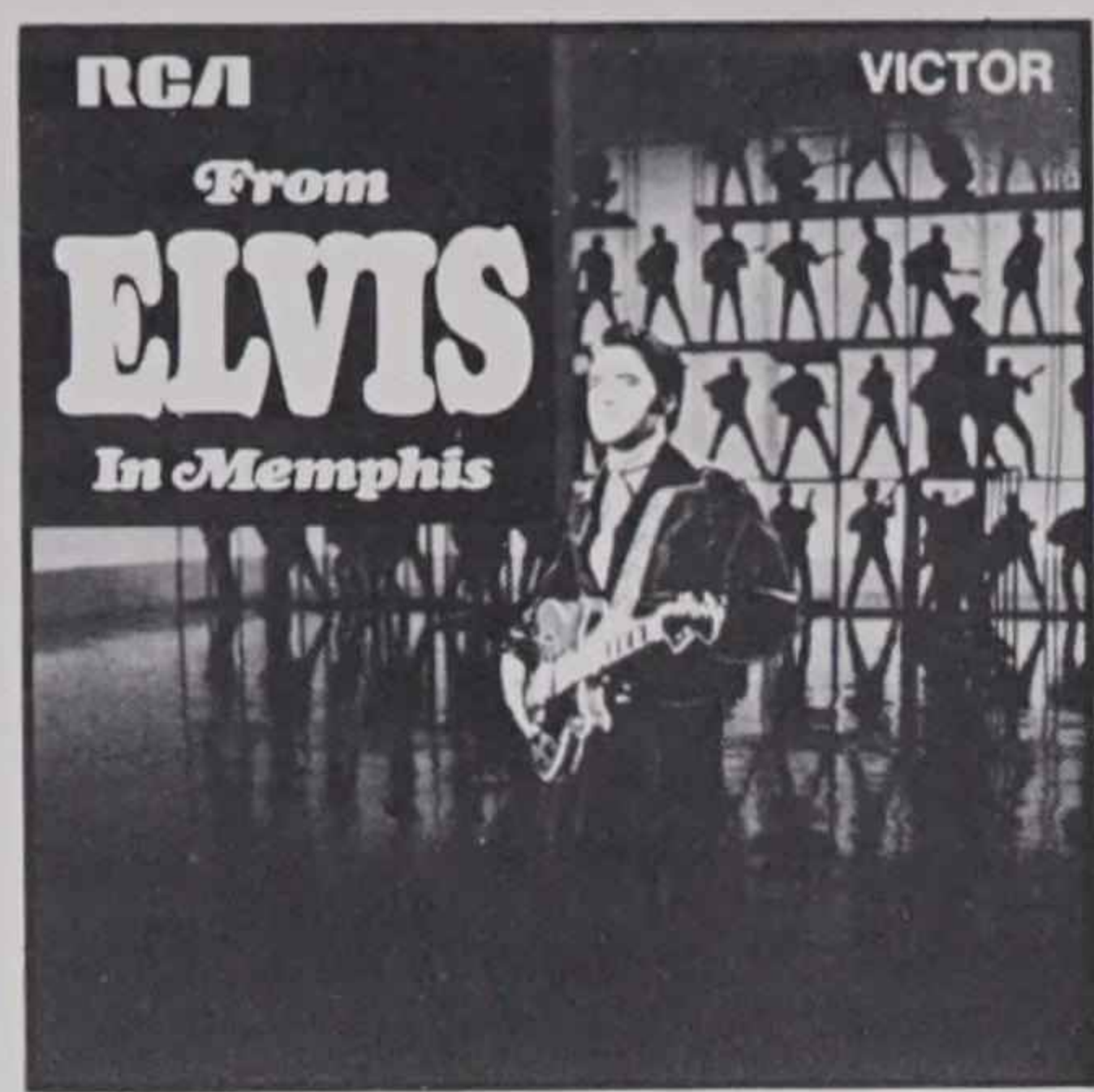

From Elvis in Memphis
Elvis Presley LSP-4155

This is Elvis Presley's first non-sound-track album since his 1967 Grammy-award-winning sacred collection, "How Great Thou Art." For this recording, Presley returned to Memphis, the scene of his first triumphs. He has put together a dozen selections that include familiar country and pop favorites as well as exciting new material. Featured are his current hit single "In the Ghetto" and the Bob Hilliard-Burt Bacharach song "Any Day Now." Also included are John Hartford's "Gentle on My Mind," Hank Snow's "I'm Movin' On," the Eddy Arnold favorite, "I'll Hold You in My Heart" and Johnny Tillotson's "It Keeps Right on A-Hurtin'."

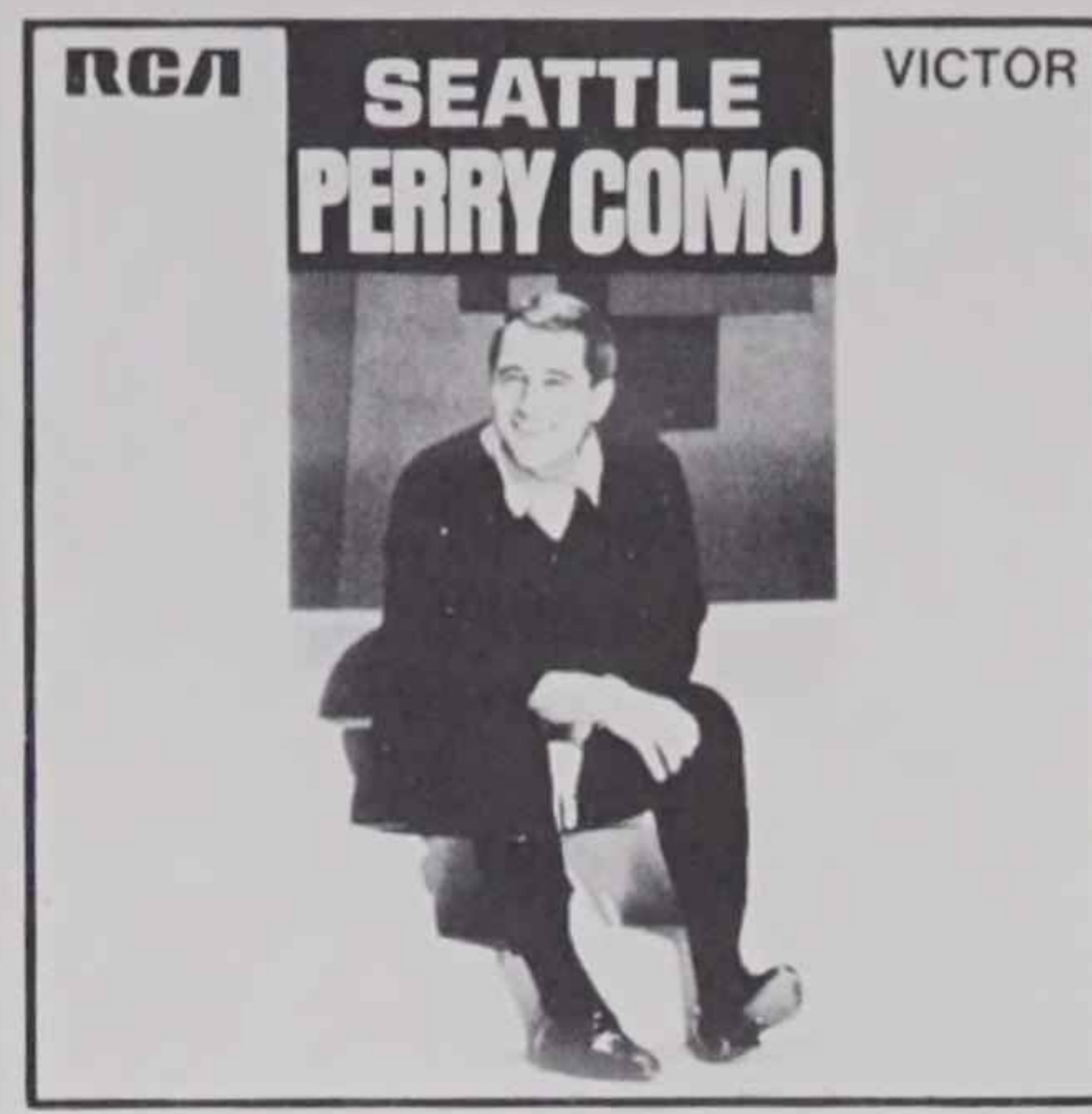

Seattle
Perry Como LSP-4183

Of all the popular artists on the RCA roster, none has the longevity of Perry Como, who is now celebrating his 25th consecutive year with the label. Featured on the album is his current hit single "Seattle," which is a vocal version of the Hugo Montenegro-Ernie Sheldon theme for the TV series "Here Come the Brides." Also included are "Together Forever" from the Broadway show *I Do! I Do!*, a contemporary folk song "Turn-around," and from the country song field "That's All This Old World Needs," "Hearts Will Be Hearts" and "Deep in Your Heart."



Brahms: The Three Piano Quartets, Op. 25, 26 and 60
Schumann: Piano Quintet in E-Flat, Op. 44
Artur Rubinstein, pianist
The Guarneri Quartet LSC-6188

The works recorded here — together with the previously recorded Brahms F-Minor Piano Quintet (LSC-2971) — represent the best romantic chamber literature for strings and piano. Both Brahms and Schumann were accomplished pianists and produced works for the piano that make great virtuosic demands. The first two Brahms Quartets were completed in 1861, the third in 1873. The Schumann Quintet, composed in 1842, is the best known of his chamber works.



Schubert: Symphony No. 8 in B-Minor, D. 759 ("Unfinished")
Mozart: Symphony No. 41 in C, K. 551 ("Jupiter")
Eugene Ormandy conducting the Philadelphia Orchestra LSC-3056

Combined in this Red Seal recording are two of the most popular standard orchestral works in serious music. They were recorded in the Academy of Music, Philadelphia, shortly after the Orchestra returned to the RCA label after a 25-year absence. The "Jupiter," Mozart's last symphony, was written in the grand style, and Eugene Ormandy uses 48 string players in addition to 14 wind and percussion players to create as authentic a performance as possible.



A Pops Serenade
Arthur Fiedler conducting the Boston Pops Orchestra LSC-3023

This album presents Arthur Fiedler and the Boston Pops in a field in which they have no peers — the light classics, or what was once termed salon music. Featured are works that span nearly three centuries, from an eighteenth-century minuet by Boccherini to the 1925 Percy Grainger composition "Country Gardens." Included are serenades by Schubert, Drigo and Toselli, intermezzos by Mascagni and Granados, and such other favorites as Mendelssohn's "Spring Song" and Tchaikovsky's "None But the Lonely Heart."

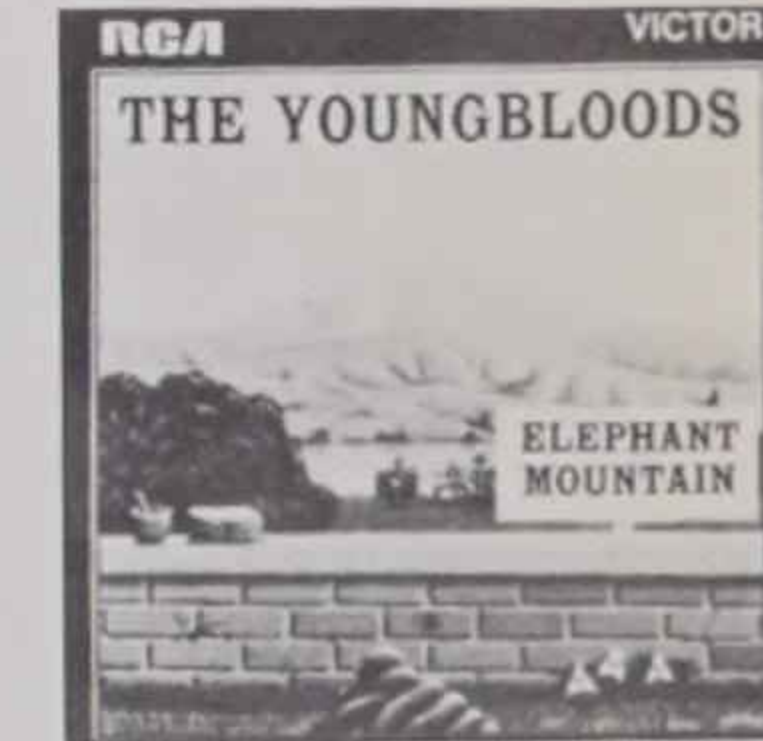

Other Current RCA Releases

Aviation: On the Threshold of a New Era

Giant aircraft, supersonic jets, and commercial planes that can land in the heart of a metropolis will help aviation keep pace with the continuing passenger boom.

by Norman H. Solon

In mid-December, if all goes as planned, a giant Pan Am Boeing 747 jetliner, with 362 passengers aboard, will rise from the runway at John F. Kennedy International Airport and open a new age of aviation. This will be an age in which more people will travel faster and with greater convenience. Paris will be only two hours and 40 minutes from New York, and Tokyo less than three hours from Honolulu. During the 1970s, as many as 600 persons may be able to cross oceans and continents in a single plane that is more comfortable and even more reliable than are today's jets. And a businessman may be able to board an aircraft in midtown New York and land minutes later in the heart of Washington. Within a decade and a half, total passenger miles will soar from the present 200-billion-a-year figure to more than 1 trillion.

By 1972, the long-range 747 jumbo jets will be joined in service by two versions of the 350-passenger, medium-range airbus — the McDonnell Douglas DC-10 and the Lockheed L-1011. The airbuses

Norman H. Solon is on the RCA Public Affairs staff.





"Paris will be only two hours and 40 minutes from New York."

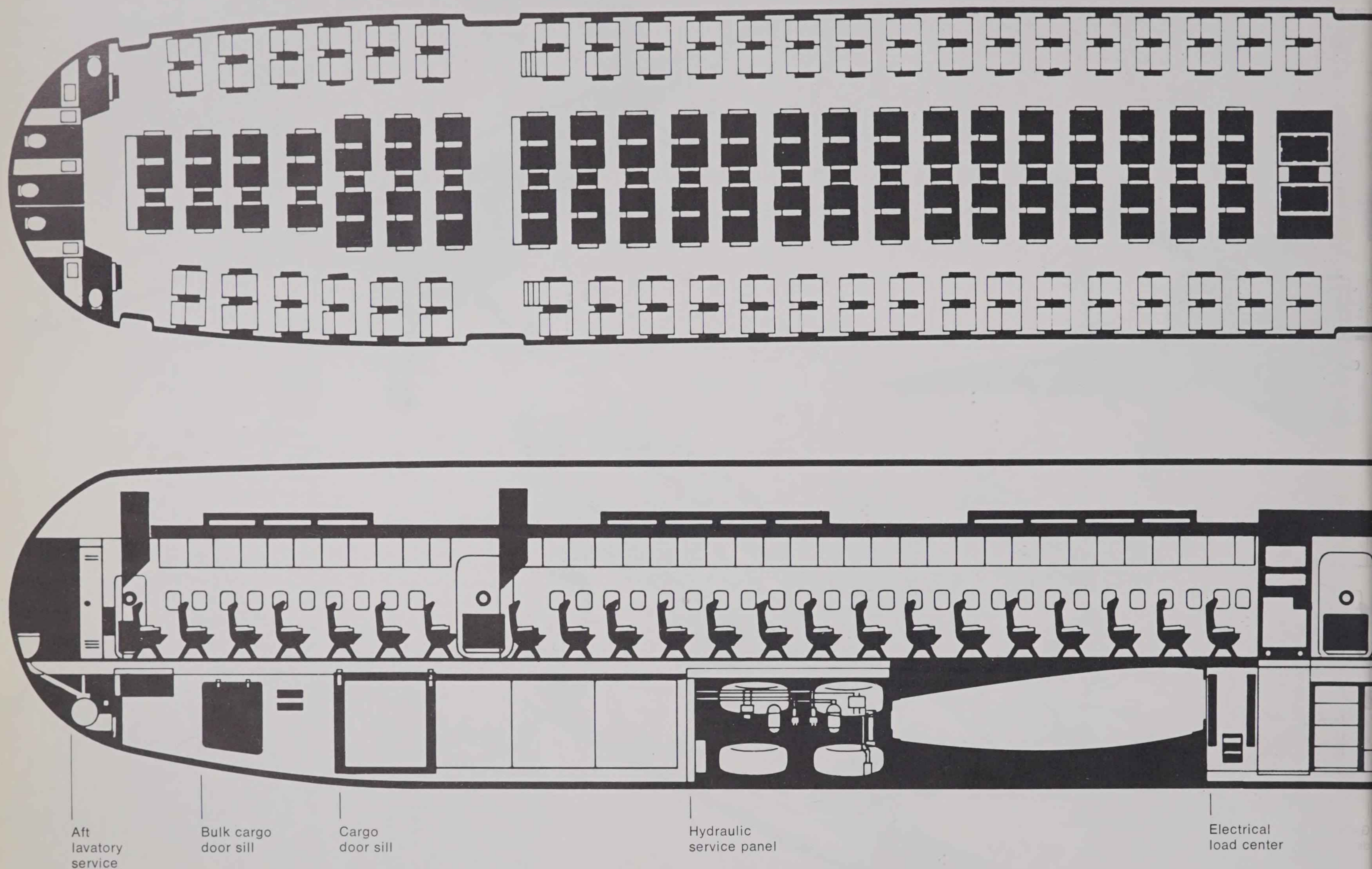

have a range of 4,500 miles and are capable of operating on existing runways like those at Midway or LaGuardia airports. The heavier 747s have a 6,500-mile range and can land at most of the larger airports such as Kennedy and O'Hare. Commercial aviation will also go supersonic in the '70s, at least for overseas flights. A technological breakthrough is needed before the sonic boom can be eliminated or suppressed to a point that would make overland flights feasible.

The Russian supersonic TU-144 already has been tested and may go into service between Moscow and Tokyo by next summer. Soviet supersonic flights between Moscow and New York may begin later that year. The Concorde, a joint British and French effort, is expected to make its maiden commercial flight in 1972. However, the American entry — the swept-wing Boeing supersonic transport (SST) — is being held up at the blueprint stage because of government funding problems and will probably not make its

debut until 1976 at the earliest.

Short takeoff and landing (STOL) craft are expected to open such new vistas for aviation in the next decade as downtown-to-downtown flights between relatively close metropolises and economical, regularly scheduled taxi flights from suburban areas to major airports. American Airlines, for example, has tested the feasibility of scheduling STOL flights between St. Louis and Chicago, using Meigs Field — which is located on the lakefront less than two miles from the Loop — as one terminal. And a recent emergency airlift exercise, conducted by the Federal Aviation Administration, successfully used a pier on the New York waterfront and a small downtown Manhattan playground as STOL landing strips. The Port of New York Authority is now operating a STOL strip at LaGuardia Airport and planning others at smaller ring airports in the New York metropolitan area.

These developments will help commercial aviation cope with the expected

continuing boom in passenger air travel during the next 15 years. Several reasons exist for this optimism concerning commercial aviation. There will be more potential airline passengers in the United States. In spite of the pervasiveness of commercial aviation in today's society, airline passengers still form a fairly exclusive club. According to Robert Fulton, an FAA spokesman at Kennedy Airport, some 65 per cent of the American public, including a large proportion of older people, have never boarded an aircraft. This percentage will shrink perceptibly in the coming years when even senior citizens will have grown up as part of an air-minded generation.

Another reason for the expected increase in air passengers is that STOL craft may prove to be the answer for intercity travel within highly populated regions such as the Northeast Corridor. If so, commercial aviation will attract new business from the crowded highways and inadequate railroad systems.

The new generation of aircraft will bring advances other than greater efficiency in transporting passengers. The giant jets will emit almost no smoke during takeoffs and landings, thus relieving air pollution problems around major airports. Also, they will be less noisy than the smaller jets that they replace. According to the FAA, this is the first time that aircraft are being built with noise abatement as a primary operating objective. Technological advances, achieved partly as a result of a NASA-sponsored research study, make it possible to reduce jet aircraft noise by 15 to 18 decibels on landings and 12 decibels on takeoffs.

Martin Gach, FAA Eastern Regional Noise Abatement Officer, has witnessed test flights of the 747 and terms it "a quieter airplane than present long-range jets, although by no means a quiet airplane. However, its noise is less grating psychologically since it is not so shrill, and the sound decays rapidly."

In addition, Gach states that airbuses

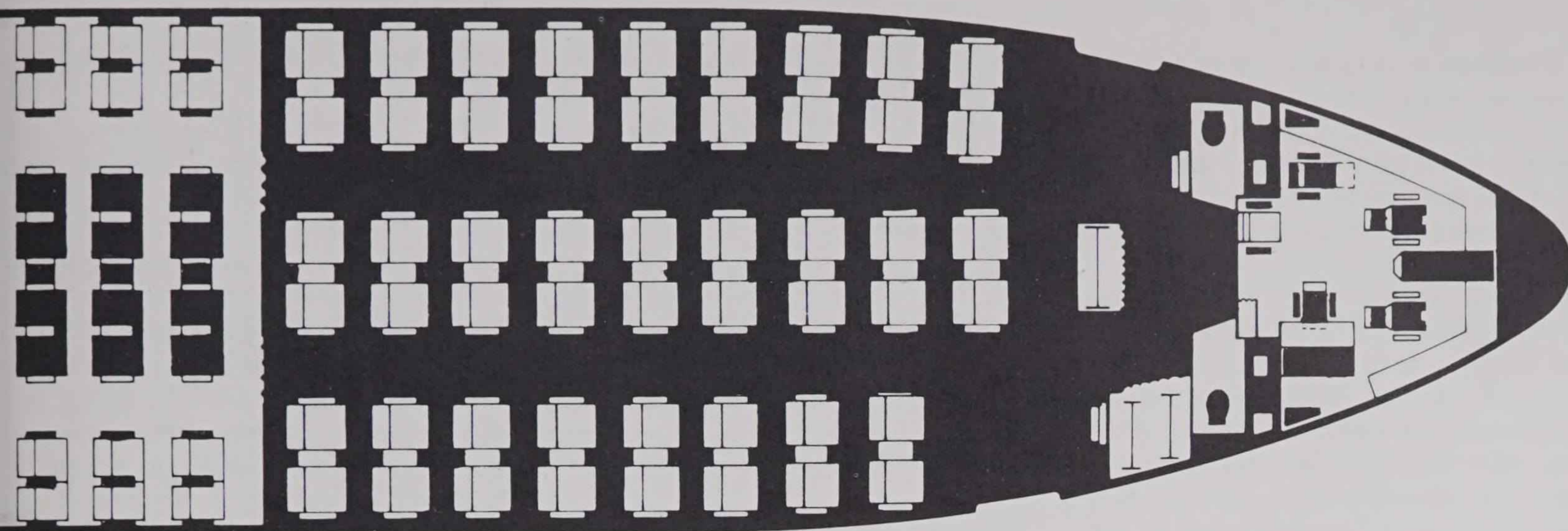

Coach First Class

Tourist and first-class seating arrangements in the standard version of the Lockheed L-1011 airbus.

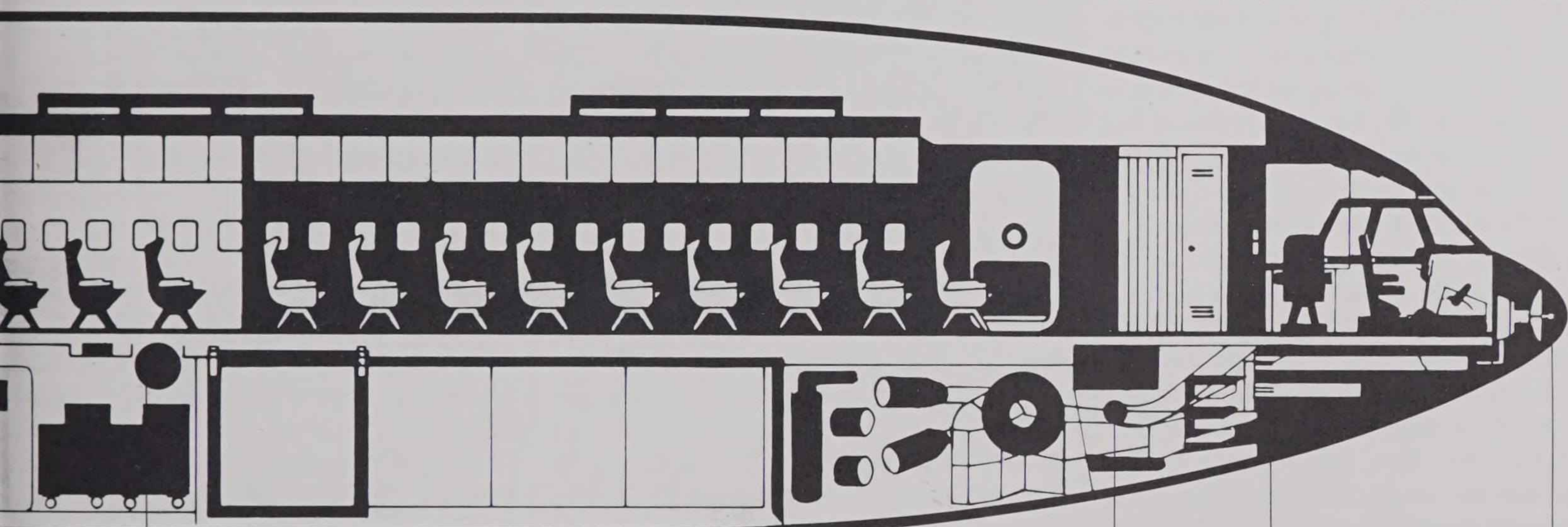

Galley floor sill Potable water filler Cargo door sill Ground electrical connection Ground air conditioning Forward lavatory service Weather radar access

will be at least as quiet as today's much smaller trijets and have less whine. McDonnell Douglas and Lockheed contend that noise levels of their models will be significantly lower. These manufacturers are spending approximately \$200,000 an airplane on noise-suppression devices, including 3,000 pounds of sound-absorbing duct lining at the inlet, the fan area of the engine and the fan exhaust area.

At the outset, the SST will not create any special noise problems since it will approach land areas only at subsonic speeds until the problem of the sonic boom is solved. According to one federal official, the initial technical breakthrough might be in reducing the resounding boom to a much less damaging "poof."

Noise reduction is extremely important if STOL is to reach its potential, since complaints from residents are almost always a fact of life whenever new airstrips are proposed for downtown or populated suburban areas. Here, too, manufacturers are focusing on noise abatement at

the project stage. Richard FitzSimmons, Boeing's director of exploratory development for commercial airplanes, claims significant advances have been made in jet-engine noise suppression for STOL vehicles. The deHaviland Aircraft Company of Canada already has what it calls "the quiet STOL airliner" on the drawing board. Designed as a possible successor to the Twin Otter, the CHC-7 will create a noise level of only 95 perceived decibels at a distance of 500 feet. This is roughly equivalent to the noise of a busy kitchen, says the manufacturer.

The giant jets will be more comfortable than most present jet aircraft, with considerably more leg room and aisle space for both first-class and economy passengers. Lockheed, for instance, claims that coach passengers will have 20 per cent more space on the L-1011 than on any existing airliner. In fact, the words "airbus" and "jumbo jet" are anathema to the manufacturers who fear that the public will conjure up comparisons to lum-



Spacious cabin of the Lockheed L-1011 airbus.

bering elephants and stark, Spartan-like buses. Actually, these new aircraft will be anything but stark. The 747s, for example, will have first-class lounges and even upper-level theaters and private state-rooms complete with sleeping quarters, depending on the needs of the individual airline.

The nearly 20-foot-wide cabins in the airbuses and jumbo jets — seven feet larger than in today's aircraft — will permit comfortable six-across seating in first class, arranged in three pairs of seats that are separated by two aisles. Economy seating will be either eight or nine across, with four twin seats or three twin seats and one line of three seats. In most cases, passengers will not be more than one seat away from the aisle. The wide cabins also will eliminate the feeling of sitting in a long, low tunnel, as is sometimes the case with present jets. Instead, passengers will have the impression of spaciousness.

Travelers on the new giant jets will be served food and beverages faster than at present and in greater comfort. For one thing, there will be no "minigalleys" in the tail or midsection of the plane as in present-day aircraft. Thus, the noise and odors associated with cooking will be kept out of the cabin. Instead, food will be prepared and/or stored in an under-floor galley complete with refrigerators and high-speed infrared ovens. This galley will be connected to the cabin by a pair of elevators where serving carts — each containing 27 meals — will be delivered to the stewardesses. Lockheed claims that as many as 324 meals can be served in less time than is needed for present operations involving half that number of passengers. McDonnell Douglas staged a recent test "eat-in" in an engineering mockup of the DC-10. It took nine stewardesses one hour and nine minutes to serve 250 full-course meals to the guests. This speed will give New York-to-Chicago passengers — even on a full 350-seat jet — more than enough time to enjoy their meal.

The new giant jets will be much more economical to operate on a per-passenger basis. Boeing, for instance, asserts that the direct operating cost per seat-mile for the 747 will be about 30 to 35 per cent lower than for the present-generation 707-320B. And operating costs for the airbuses have been estimated at less than a penny a seat-mile compared to 1.38 cents for Boeing's medium-range 727. This economy is due to technical advances as well as to increased passenger capacity. The high-intake engines in all three jets are expected to reduce fuel consumption by 25 per cent.

However, it is questionable whether these savings will result in lower fares, as John Volpe, Secretary of Transportation, recently advocated. When the jumbo jets were first announced, at least one airline official expressed hope that fares could be reduced substantially. Now, most of the talk is about holding the line. One prominent industry figure explains, "The airlines have been hit hard by the popularity of discount group flights, which have increased traffic but slashed earnings. Now, they will have aircraft that figure to be universally profitable, and they are not about to cut this profit to the bone." One spokesman summed up the general feeling of the airlines in these words, "We are looking to the 747 to enable us to hold fares at present levels. This is a reduction in the sense that other costs are going up." It would be impossible for one overseas carrier to reduce fares unilaterally, since all international fares are set by the International Air Transportation Association.

The airbuses, jumbo jets and the Boeing SSTs will be more reliable as well as comfortable and economical. They will be equipped with sophisticated electronic guidance instrumentation, including an automatic all-weather landing system and the most versatile all-weather radars ever built for aviation, such as the RCA AVQ-30. This radar has a range of 300 miles and will be installed as a dual radar system for ultrahigh reliability. With it, the average aircraft can operate for five years — 10 hours a day — without a total radar system failure. This will be a 36-to-one improvement over the equipment of today. The RCA radar console is designed to display closed-circuit TV pictures as well as radar data. Thus, by flipping a switch, the pilot will be able to see several important interior and exterior areas of his aircraft, which are monitored by small remote cameras. This will be especially important when taxiing the SST, where pilot visibility of the immediate runway will be limited by the long needle-like nose of the jet.

However, the pilots of the airbuses and jumbo jets will have greater optical as well as electronic visibility. The layout of the cockpits in the skybuses will upgrade pilot visibility by more than one-third over that of present jets. The 747 pilots also will have an increased line of sight, although less than that of their airbus counterparts because of the location of the 747 cockpits high above the passenger decks.

Most of the world airlines are still hedging their bets as far as supersonic transports are concerned. The proposed Boeing SST will be much faster and

larger and will carry more than twice the passengers (about 300) than either the Concorde or the TU-144. Based on today's economics, neither the Russian nor British/French jet — both with speed limits of around 1,400 miles an hour — would be profitable without charging premium fares. By comparison, the American SST is capable of carrying passengers across the ocean — at 1,800 miles an hour — at roughly the same return on investment as with today's aircraft. This is predicated on an average seat-mile cost of around 1.1 cents.

However, the Russian TU-144 and the British version of the Concorde already have made their appearances. And the French Concorde, together with the 747, were the focal points of the Paris Air Show held late this spring. On the other hand, the Boeing SST is still expensive paperwork. The development of two identical prototypes, as of this writing, is being held up because of uncertain funding.

The federal government is reconsidering a joint industry-government agreement under which it will advance 90 per cent of the capital with the aircraft and engine manufacturers supplying the remaining 10 per cent, plus certain commercial and capital expenditures not covered by the contract. If costs exceed estimates, the government's share will be reduced to 75 per cent. The total cost of the SST program is expected to exceed \$1.1 billion and has been called a project of a magnitude second only to that of sending a man to the moon.

Critics of the funding agreement argue that it places too high a priority for government capital on a project that is basically a money-making proposition for private industry. However, aviation officials say that the government will be repaid all invested monies plus a healthy return. An economic study by the FAA indicates that there is a market for at least 500 American SSTs. Using this figure, the U.S. government would get a \$1-billion return on an investment estimated at \$945 million.

From an operational standpoint, the American SST will reduce travel time to major overseas cities by more than 50 per cent. The aircraft will be long, sleek and streamlined, with a delta-shaped wing configuration that closely resembles the TU-144 and Concorde. However, unlike the European SSTs, the Boeing model will have a big, horizontal tail. The highly publicized variable-sweep wing design concept had to be abandoned, primarily for reasons of weight. (This concept would have had a giant hinge move the wings in flight — straight out from the fuselage during landings and takeoffs and folded



The L-1011 is the Lockheed airbus contender of the 1970s.

inside the tail when supersonic speeds were reached.)

The jet will be built of titanium and powered by four turbojet engines, each producing more than 60,000 pounds of thrust. According to Boeing, if funding problems are solved immediately, the first SST could be flying by 1972 and enter airline service four years later.

These new jets may prove to be the answer to medium- and long-range passenger business in the next two decades, but commercial aviation is turning to STOL for shorter hauls. Flights of less than 300 miles have never been profitable for the major airlines and, during the past decade, have become an even greater drain on earnings. On short hauls, over-all costs have gone up because jets can not save enough in cruising time to make up for increasing per-passenger costs and rising per-flight expenses in taxiing, waiting and holding time.

Airlines have been forced to anticipate delays averaging 19 minutes in making up schedules for their Boston-New York and Washington-New York shuttle flights. A new generation of STOL craft could change all that. For instance, Boeing estimates that the number of airplane movements per hour at Los Angeles International Airport can be almost doubled if a special STOL strip is constructed and new short-range vehicles are developed. Present commercial STOL craft are too slow and too small for use other than as sky taxis, and rotary aircraft have proved economically unfeasible. Direct operating costs for helicopters usually are around 20 cents a mile for runs longer than 15 miles as compared to four to five cents for an equivalent STOL craft. However, such manufacturers as McDonnell Douglas and Boeing maintain that STOL craft capable of higher speeds and with adequate passenger capacity could be built quickly. In the future, high-speed, tilt-wing vertical takeoff and landing (VTOL) craft may be developed, although the economics of VTOL are debatable.

STOL craft requirements were outlined by A. Scott Crossfield, an Eastern Airlines flight research and development executive, based on tests conducted in the Northeast Corridor with the McDonnell Douglas-188. "The airplane that we need generally will have the capacity of carrying 100 or more passengers. It should have a speed of something like 400 miles an hour and be capable of using a runway of 1,500 to 2,000 feet. The interior of the plane would probably have two aisles and no more than two seats per row. One reason is that the versatility and utility of the airplane depend on the ability to get people on and off quickly."

Although unused space and old taxiways at most airports could be converted to short landing strips, federal agencies such as the Civil Aeronautics Board want most STOL terminals to be located in downtown and central suburban areas. The FAA issued a list of 20 possible STOL sites in the Northeast Corridor last year, including four in downtown Manhattan. Almost all planners are convinced that the key to general acceptance of midtown-to-midtown STOL service is for the concept to be accepted in New York.

The potential of STOL in New York is recognized by most carriers. Crossfield predicts that "assuming a 100-passenger vehicle with a 20-minute minimum turnaround, we can see that, by 1973, New York will require a midtown STOL port with a 1,500-foot landing strip and at least eight gate positions. By 1980, the requirement may well be 30 to 40 positions."

The development of new-generation aircraft, while providing more efficient air transportation, further aggravates the problem of overcrowded airports. Airline service crews will have to deal with hundreds of passengers departing from a single aircraft and all wanting their luggage at the same time. Various possible solutions are being studied, some involving sophisticated electronics. One airline executive spoke of a computerized system with several input points located throughout a metropolitan area. The baggage would be assigned electronically, via the fastest possible route, to the passenger's destination, where it would be centrally stored. When the passenger arrived, he could simply insert a key in an output station and his bag would be retrieved in the same manner that information is called up in a computer.

Pan Am already has adopted the satellite baggage station concept. Passengers going to Paris from New York can, for example, check their bags at Roosevelt Field on Long Island or at other suburban locations and avoid standing in line at Kennedy Airport.

The coming of the giant jets is also a nightmare to customs officials, who are considering further decentralization of customs activities away from international arrival buildings and into the various individual airline terminals. Other solutions may involve in-flight customs checks and U.S. customs stations in foreign countries — such as now exist in Canada and Bermuda — if permission is forthcoming from other governments. However, there are drawbacks to all these possibilities.

Another major problem is the increased need for ground transportation between airport and city. Cleveland is the only

major city that has a direct rapid transit system connection to the airport. But regular users of the transit system complain that airport passengers cause monumental jam-ups, especially during rush hours.

In New York, several ground transportation proposals have been considered. The Port of New York Authority had advocated a vehicle that could be converted from bus to train, depending on the traffic. The Kennedy-bound rail-bus could either travel on the highway or along a parallel railroad spur. Another proposal called upon the Long Island Rail Road to build a spur to Kennedy Airport. However, a direct rail link to a midtown terminal is now planned, so airport traffic will not further overcrowd the busy suburban railroad.

All new and proposed airports have given primary consideration to ground transportation. Houston's new Intercontinental Airport is located 16 miles from the heart of the city between two major freeways. And the availability of 100-mile-an-hour trains from runway to midtown is an important factor in studies now being conducted regarding a site for a fourth jetport in the New York area.

In any case, the new era of aviation will be a reality long before all ground problems are solved. As an FAA official put it, "cars were here long before super-highways." ■

New systems, such as the one shown here, are being developed to expedite luggage handling.



Young Scientists of Today

They are intellectually gifted and hardworking, but their lives do not revolve around a test tube.

by Nicholas King

The young scientists of today form an intellectual elite but belong to no special breed. In fact, they are extremely hard to categorize and almost impossible to stereotype. Though they may display the modesty of excellence, young scientists — industrial scientists at any rate — do not play the role of members of a caste.

There are approximately a half-million scientists now employed in the United States, an increase of almost 100 per cent during the past decade. Add a million-and-a-quarter engineers (the line dividing them grows increasingly fuzzy) and you have a population large enough to occupy a sociological niche all its own. Clearly, a great proportion of them are young. Where do they come from, and what are they like?

"There's been a big change in the image of the scientist — and in the scientist himself in the last 15 or 20 years," says Dr. William M. Webster, Vice President of RCA Laboratories in Princeton, N.J. "Scientists used to be thought of as bearded eccentrics living in a garret and starving for their causes. I once made a survey of my scientific colleagues and then of my other friends. The question was: 'Did you have a happy childhood?' The scientists responded 80 per cent in the negative, and the others 80 per cent positively. But you wouldn't find anything like that percentage difference now."

Webster, who looks more like a forest ranger than a scientist, presides over a large, multi-elled brick building set among flowers and trees, a mile or two from the university town. The scientists — who seldom wear white coats — go in and out of the labs, creating an air of orderly bustle.

The bulletin boards posted along the walls have their quota of official announcements, but they also advertise a house choral group and competitive bowling schedules, like any plant or office. One problem science hasn't overcome is the flight of birds into the clear plate glass enclosing the bridges that run between various wings of the building.

Nicholas King is on the RCA Public Affairs staff.

So, dummy owls have been strung on vertical wires to frighten off the birds.

Webster points out that just as scientists no longer act in the same way, they don't look the same. "Twenty years ago, you could always tell a scientist at a social function, if any of them bothered to come. Today, they look and act like anyone else, both professionally and socially." These days, the prestige of science and the fact that scientists are well paid fit the younger men into the community in a broader and more satisfying way. Their social life tends to involve neighbors with common community or social interests rather than each other, although colleagues frequently mingle socially. The point is that no one is conscious of this fact one way or another.

How important is dedication to science as a job factor? Not very, according to Dr. George Heilmeier, renowned at age 32 for his work on liquid crystals. "No, I wasn't oriented toward a scientific career. When I was in high school, I wanted to go into physical education. I also considered the service academies. But my school counselor wanted me to make a career in science or engineering. I received a scholarship from the University of Pennsylvania, which didn't have a physical education major, so I went into engineering. Everybody told me that scientists make a lot of money."

Heilmeier has been with RCA for 11 years, the first four of which were divided between work at the labs and getting a Ph.D. in solid-state electronics from Princeton University. He is in the process of finishing a house in Bucks County — he and his wife were virtually the contractors — where they will move from Philadelphia. He's been active in competitive athletics in the city and as an elder in the United Presbyterian Church. He is articulate on many of the questions that affect his scientific career.

"I don't see any conflict between industrial management and the pursuit of research. Company policies don't cramp my style. The policies are rational. If, for example, we want to keep something under wraps, it's because I myself don't think it should be published, not because someone up the line thinks it's policy."

Heilmeier is not impressed by the argument that universities provide both a better atmosphere for the researcher and more gratifying rewards. "If industry wants to create a university atmosphere, it usually can do it better. Take the case of liquid crystals. We were more excited by the commercial potential of liquid

Dr. Levine: "I do what I like doing . . ."

Dr. Webster: "Twenty years ago, you could always tell a scientist at a social function, if any of them bothered to come."

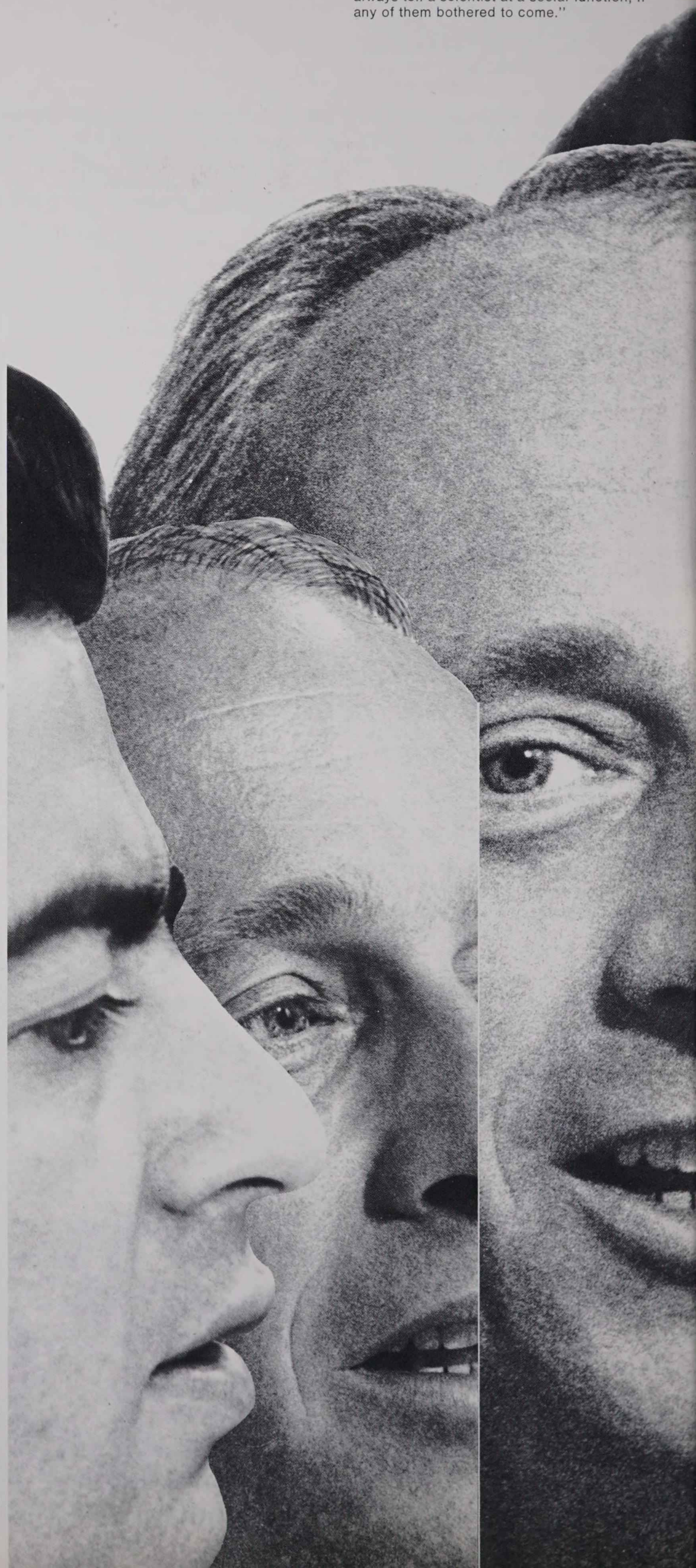

Dr. Alphonse: "Everyone should have an opportunity to learn, and the racial barrier must be broken."

Dr. Heilmeier: "Company policies don't cramp my style."



crystals than in the publication of some half-baked piece of work that is only theory. Publication is only one reward — there are others. University people aren't as free as they think they are. Suppose two people start graduate school with the same qualifications. One does all his work in the university, while the other does his course work in class but his laboratory work in an industrial lab. Five years later, the industrial fellow usually will be much more productive in terms of patents, publications and conference presentations. Graduate students who stay in universities can become victims of a form of bondage. They are useful to the professors, but not to themselves. They can stay there for six or seven years and do the same thing too long. They become too accustomed to the specialized academic world that they inhabit. Some university people write books about how everyone in the world is a backbiter and dishonest, but what they're really writing about is their own math department."

What about a scientist's involvement in the world around him, in politics and community life? Heilmeier leans back, puts a hand through his dark brown hair and looks out the window. "Scientists are supposedly rational and unemotional and detached in their work, but they turn out to be no more rational than anyone else when it comes to general issues. Too often, the criticism I hear is not scientific but political."

Most of the scientists work a regular day, but some can be found at the labs at any hour. The RCA Laboratories are open 24 hours a day and seven days a week, so that any scientist in hot pursuit of a theory or a solution has access to his work.

Broadly speaking, there are two kinds of work for the scientist. The first is conceived as a result of the interest and desire of the individual and is directed only to unassumed ends. The second consists of projects involving teams that are organized by management toward specific goals. In both cases, the emphasis is on mobility — not confining the scientist exclusively to one area.

A wag once characterized the difference between these two forms of work as "the difference between basic and applied research," and, indeed, the theoretical conflict is a subject that often comes up in debate. As Webster put it, "It's not a question of loyalty to one's profession or to one's employer or to oneself. In fact, I want a better word than loyalty; you might say relationship, or better yet, identification. Each individual has a different balance, but we don't find that a conflict develops, except in rare cases.

The question doesn't even arise most of the time. The initial identification is naturally with career, but it rarely matures into an issue."

Dr. Jules Levine, another young scientist, feels that he has plenty of freedom to consult and investigate. "I do what I like doing" is the way he puts it. Levine is a sculptor, painter, double-bass player and a couple of other things, but in the lab he is a specialist in surface physics. His bulletin board displays photographs of some of his latest sculpture, in particular a clay head of Don Quixote. "I live in a big house and I allow only my own works there. I was awarded honorable mention in a show here at the labs the other day. I played the double bass in the MIT symphony orchestra and used to play in nightclubs to help pay my tuition. I was a member of Local 802, American Federation of Musicians, for seven years.

"I went to the High School of Music and Art in New York City and had the ambition to be an artist. But in my junior year, my geometry teacher told my mother that I'd make more money in mathematics and asked, 'Do you want him to become a starving artist?' My situation here is obviously better. Anyway, research is like painting — every time you move there's a new problem. You've got to know when to stop working on a painting. The same is true of many of the problems in science. It's the variational principle of physics that tells you when you've reached the optimum."

The layman characteristically wonders how the scientist of today regards the uses made of his discoveries. The scientist of yesterday was certainly conscious of this, at least in a few celebrated applications such as the first nuclear weapons. However, many of today's younger scientists are inclined to scoff at notions of guilt. As one stated, "if you start to rationalize that way, you might as well indict Roger Bacon (or his reputation) as a war criminal for the introduction of gunpowder in western Europe."

The young scientist tends to be only moderately involved in the issues of the day, and his views tend to be liberal rather than radical, paralleling those of other members of his generation.

Take the subject of campus rioting. It wasn't too long ago that Levine was a student himself — he's only 31 and looks even younger with his shock of black hair. "It's hard to say why students are behaving the way they do. Perhaps the liberal arts students have too much free time. They're using that time to do lab work for the civil affairs they're studying. Besides, the universities are ripe for conquest. It's easier to capture a university

than it is to capture a bank. On the other hand, I was a co-chairman for Gene McCarthy near here in New Brunswick, and I saw how intellectual people work together — it's very hard to get them to agree on anything. You couldn't say that I'm particularly politically oriented. I just wouldn't want the American Physical Society to hold its convention in Chicago."

Involvement strikes Dr. Gerald Alphonse, a 33-year-old Haitian-born electrophysics expert, in another way. At present, Alphonse is working on the acoustic deflection of light and also teaches night courses in electrical engineering at LaSalle College in Philadelphia. He talks softly, and his English still betrays a trace of his native French.

"Color has never been a bar to me in my scientific work. I come from the oldest independent black country in the world. My father is a civil engineer, and I was always interested in science as a boy. I did experiments out of physics books. After I finished at St. Louis de Gonzague (an outstanding Haitian high school), I was admitted to New York University. Two years ago, I got my Ph.D. from Brooklyn Polytechnic. There is no discrimination in scientific circles, and I can ignore those people who show race prejudice. Their feelings don't bother me as long as they don't get in the way of what I need to do.

"Some of this university turmoil may be understandable, but what I'm afraid of is that riots and the changing of standards will result in a reduction of quality. From a scientific point of view, excellence is required. But everyone should have an opportunity to learn, and the racial barrier must be broken. However, I wouldn't condone demands for changes just for the sake of change. I think that what needs to be done must be determined by responsible leadership. Anyway, I believe that we have reached the peak of racial trouble or have even crossed over the peak. There must be conciliation from both sides. The world should be able to survive."

Many scientists from underdeveloped countries find themselves in an ironical position. They are obliged by their careers to remain in the places where they were trained rather than return to their own countries — where scientists or any trained talents are so badly needed — because there is no field equal to their skills and no money to finance the kind of work they want to do. "The gap is too great now," Alphonse says. "There would be nothing for me to do in Haiti, no one to speak to on a professional basis if I went back now as an electrophysicist. I have no moral obligation to return to Haiti as do those who came to the United

States on scholarships. I have become an American citizen and my work is here."

The turnover at the Princeton labs varies, but the rate is about 10 per cent a year. About one out of every three who leave goes either to an academic position or accepts another job in industry. By and large, faculty salaries have caught up with industrial scales, and universities provide certain different opportunities, especially teaching. Another third of those who leave transfers to product divisions within RCA, and the remainder represents those who didn't make the grade. Surprisingly, although good scientists are in great demand, there is little of the raiding or "headhunting" that is found in other areas of industry.

Recruiting, therefore, has to be a constant activity. It involves sending scientists from the Laboratories to university campuses to interview students well in advance of thesis time. Personal contacts supplement their efforts. For instance, Heilmeier works through a friend on the University of Pennsylvania faculty with whom he studied. This professor introduces him to new groups of promising students.

Despite statistics showing an increase in the number of scientists, there is a feeling among established researchers that young people are less oriented nowadays toward science as a career than they once were. In a tumultuous world, other fields beckon strongly, and many young men and women believe that the Peace Corps, Job Corps, or work in urban affairs or narcotics rehabilitation represent a firmer dedication to aiding a threatened and misguided society.

Be that as it may, the outside observer who talks to people in the labs at Princeton or watches them at work has few qualms about the future of America's scientific resources. These men are well educated, hardworking and intellectually gifted and contribute as much to their communities as they do to their research. In a recent sociological study, scientists in America were termed "the new Brahmins." It is not a bad title, but like most so-called catchall phrases, it may catch less than it lets slip away. ■

This Electronic Age...



"Don't just sit there! If you've processed all the data there is, go out and find more data!"

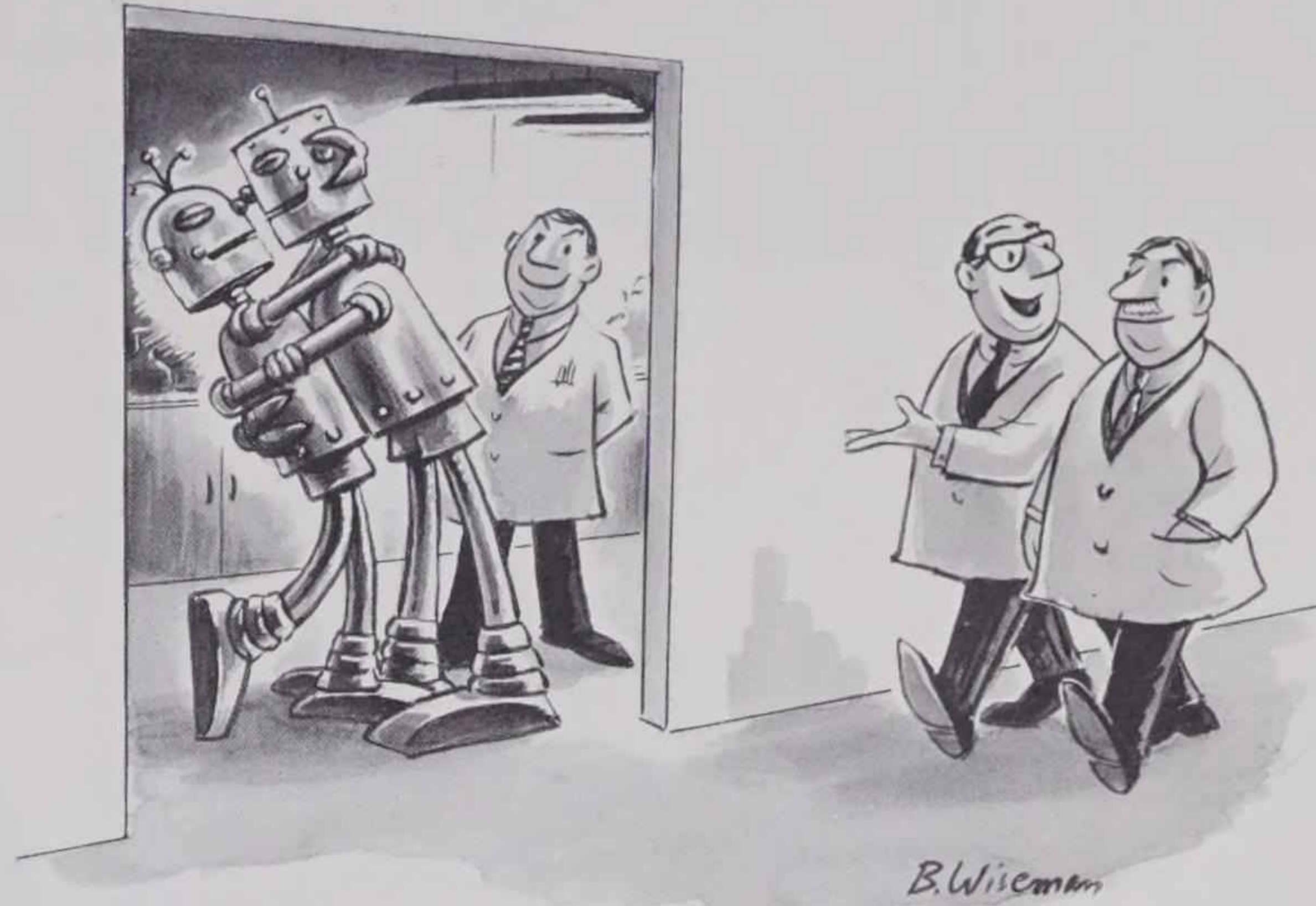

"Houston claims he's found a way to mass-produce them economically!"

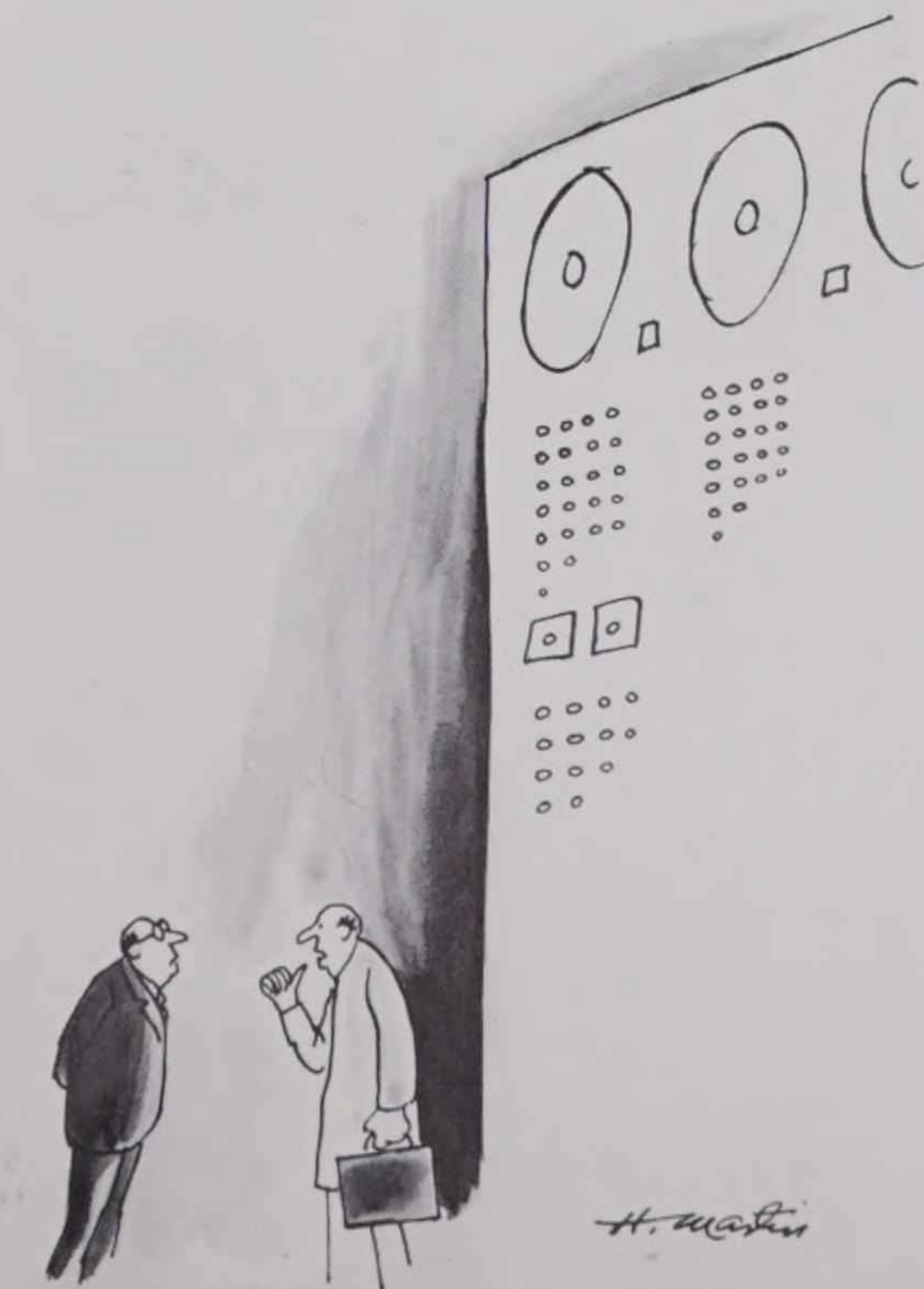
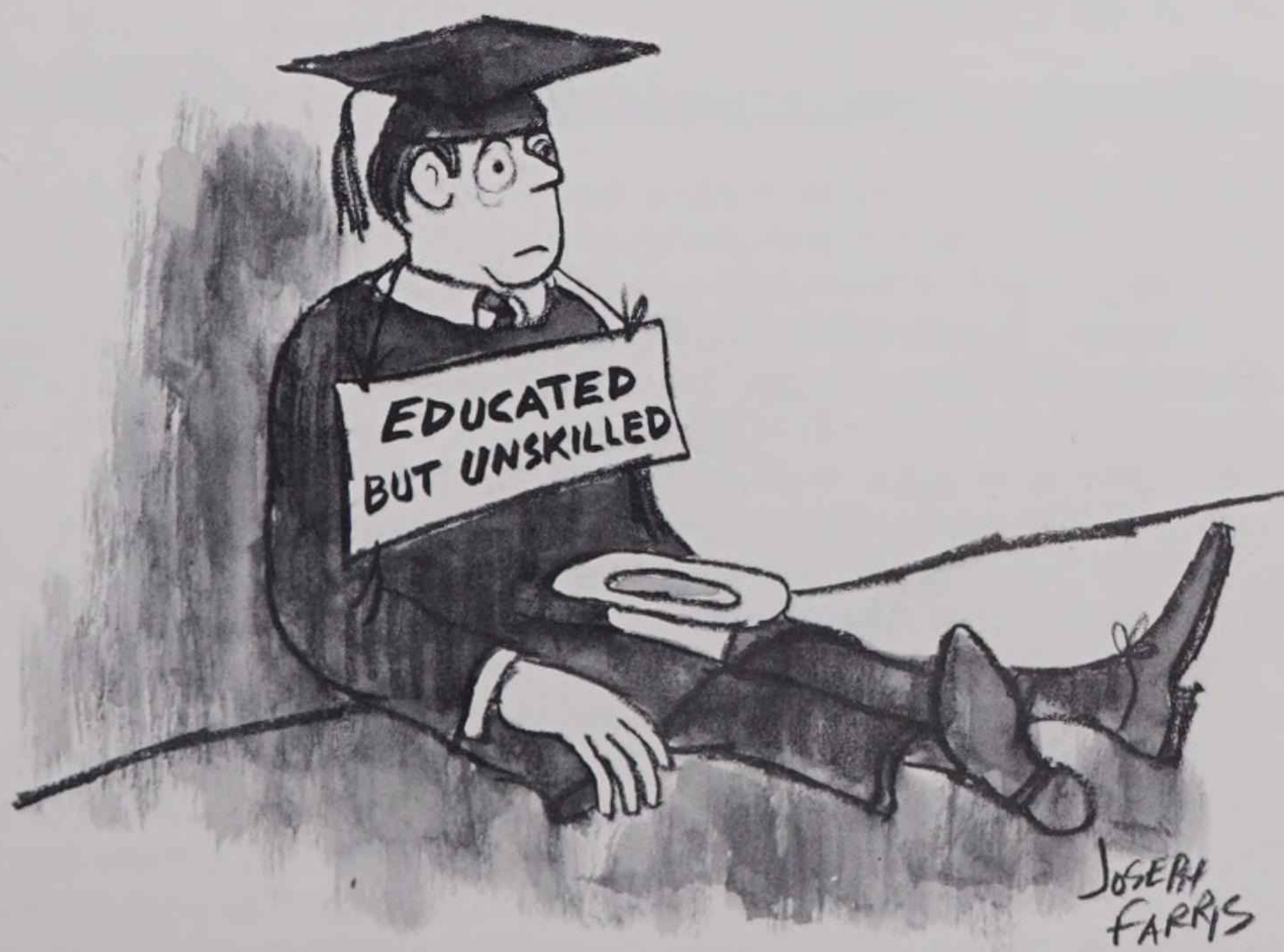
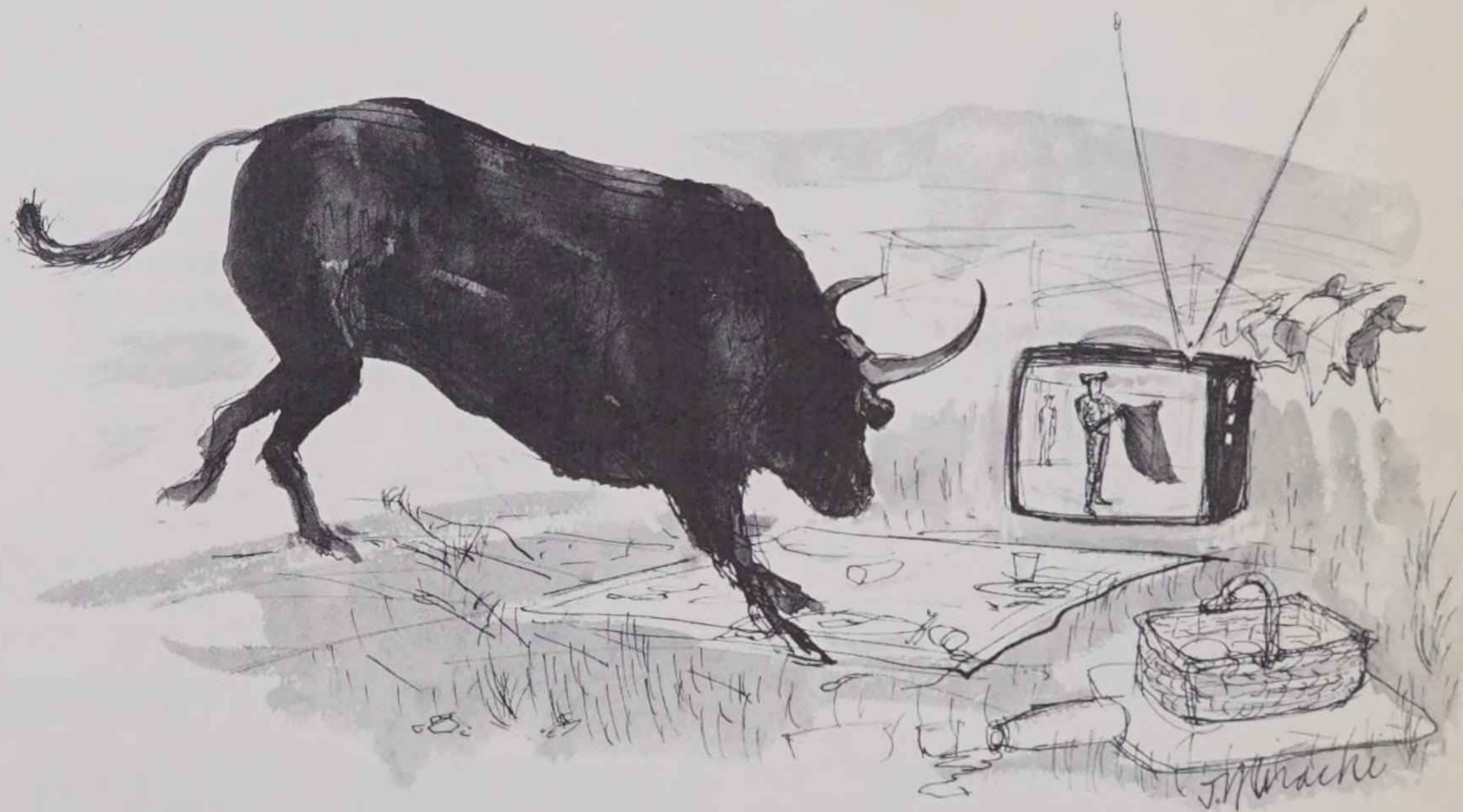

"Amnesia."

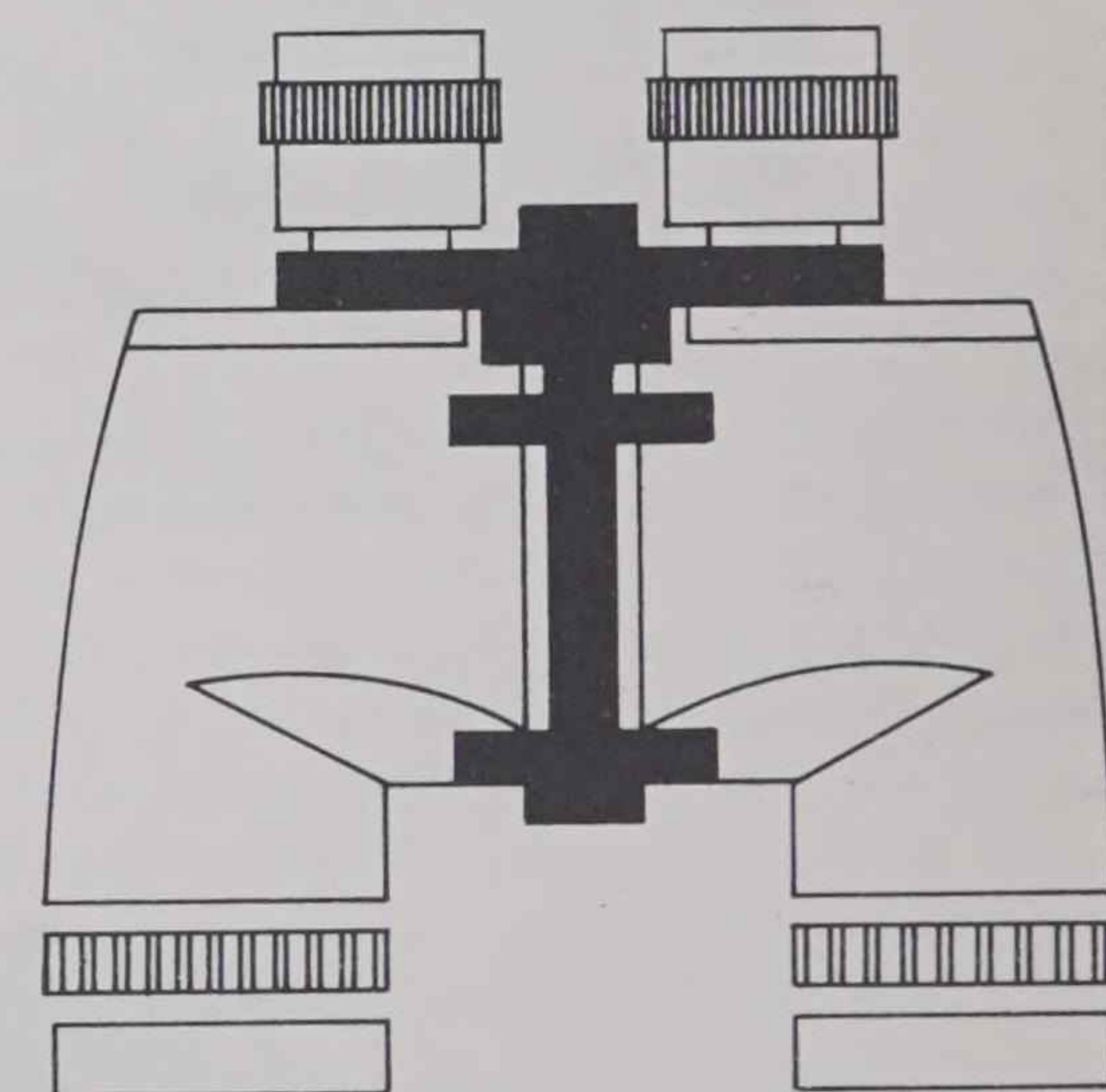
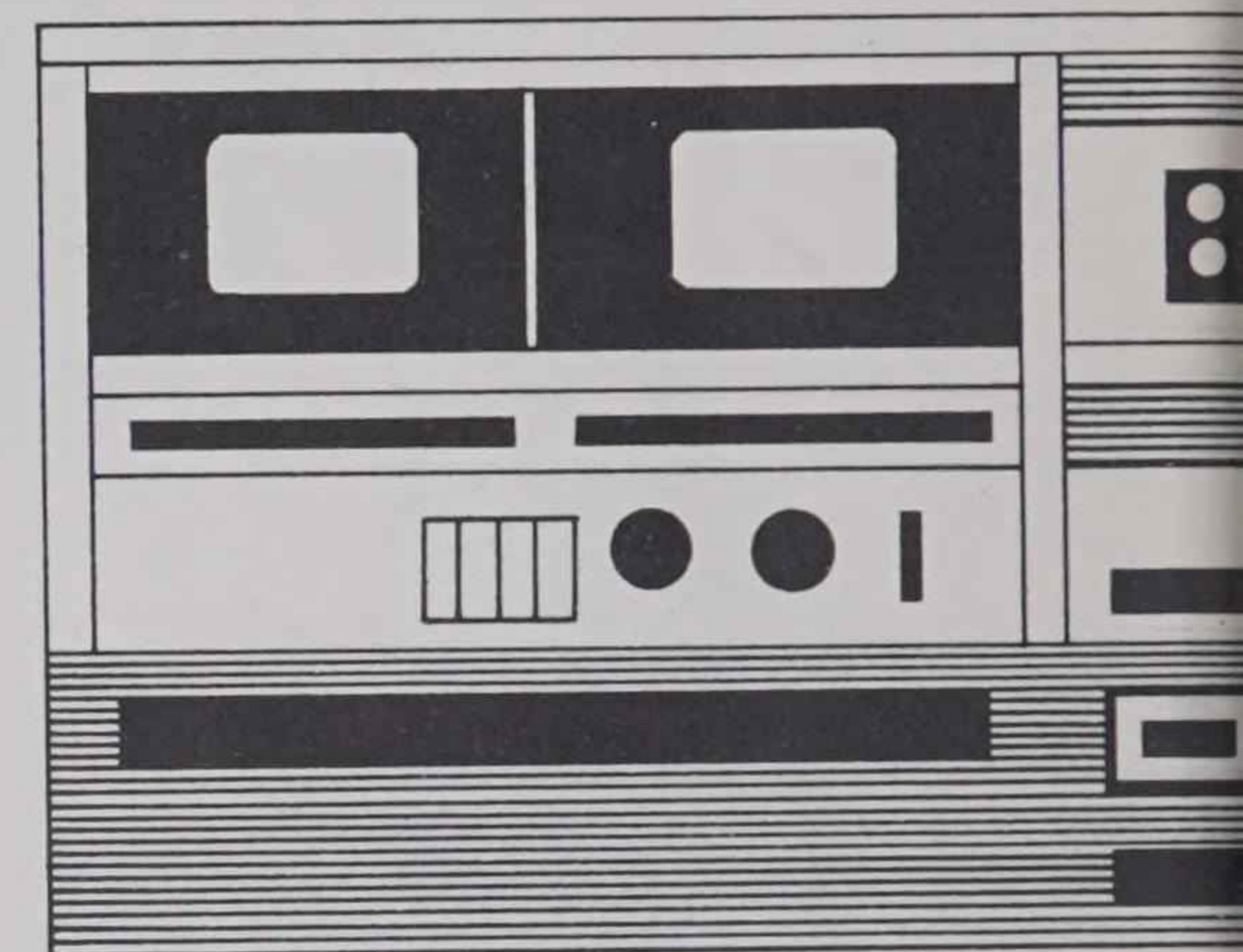
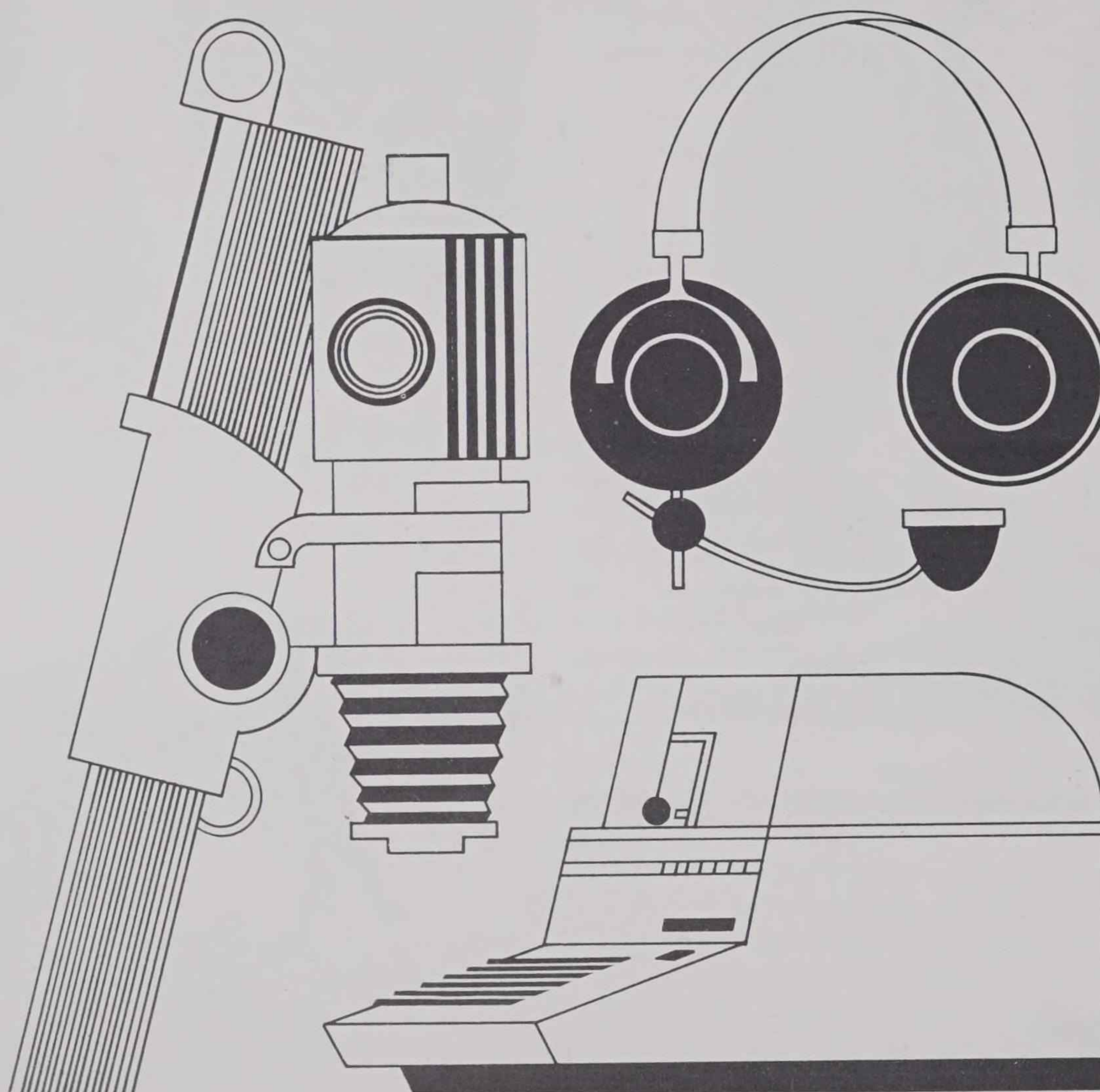
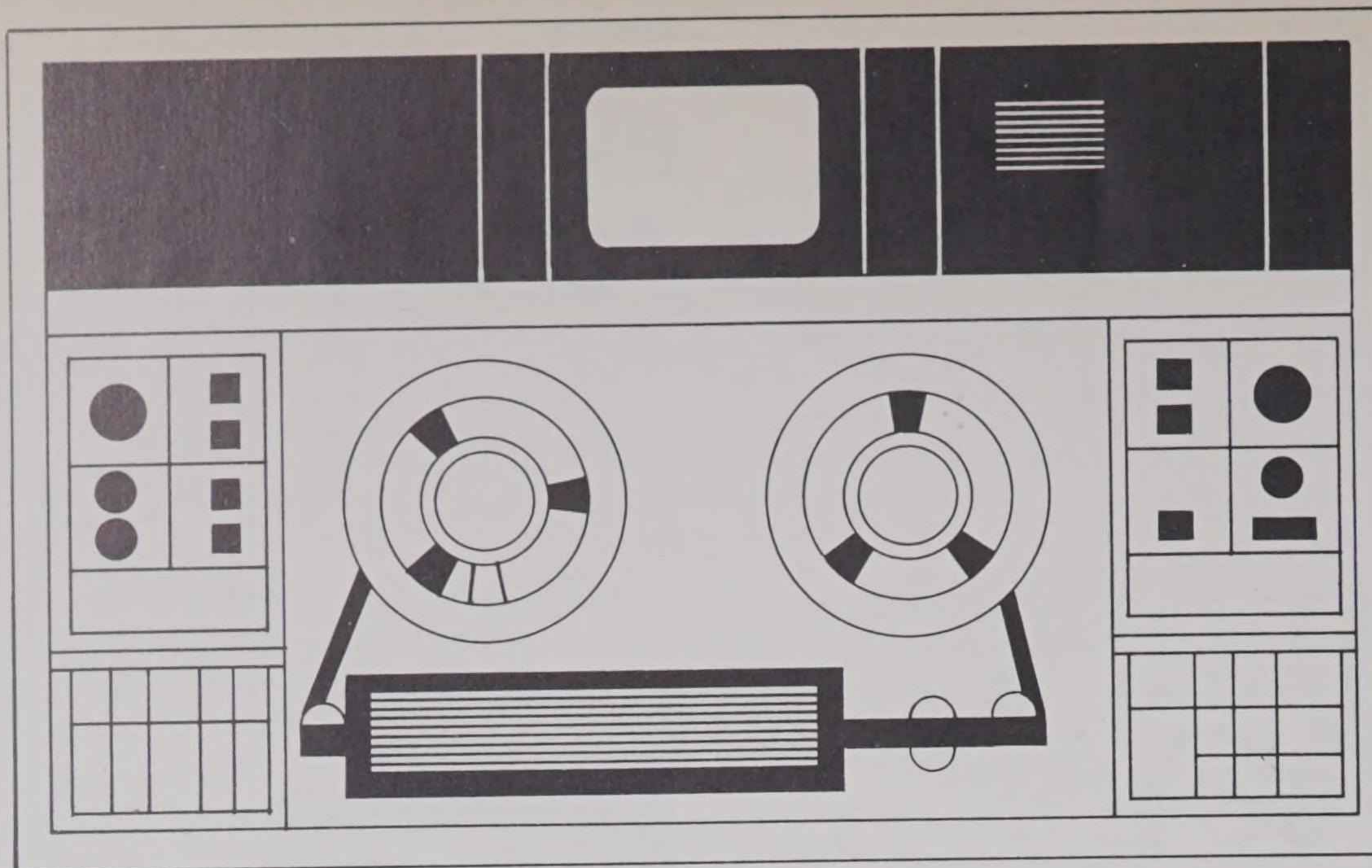

Life in the Press Box

Since upholstered chairs started to replace wooden seats in press boxes, life for the sports reporter has become more comfortable but not easier. Pressures have multiplied because of the demands of a larger audience that has become better informed through modern communications.

by Joe Garagiola

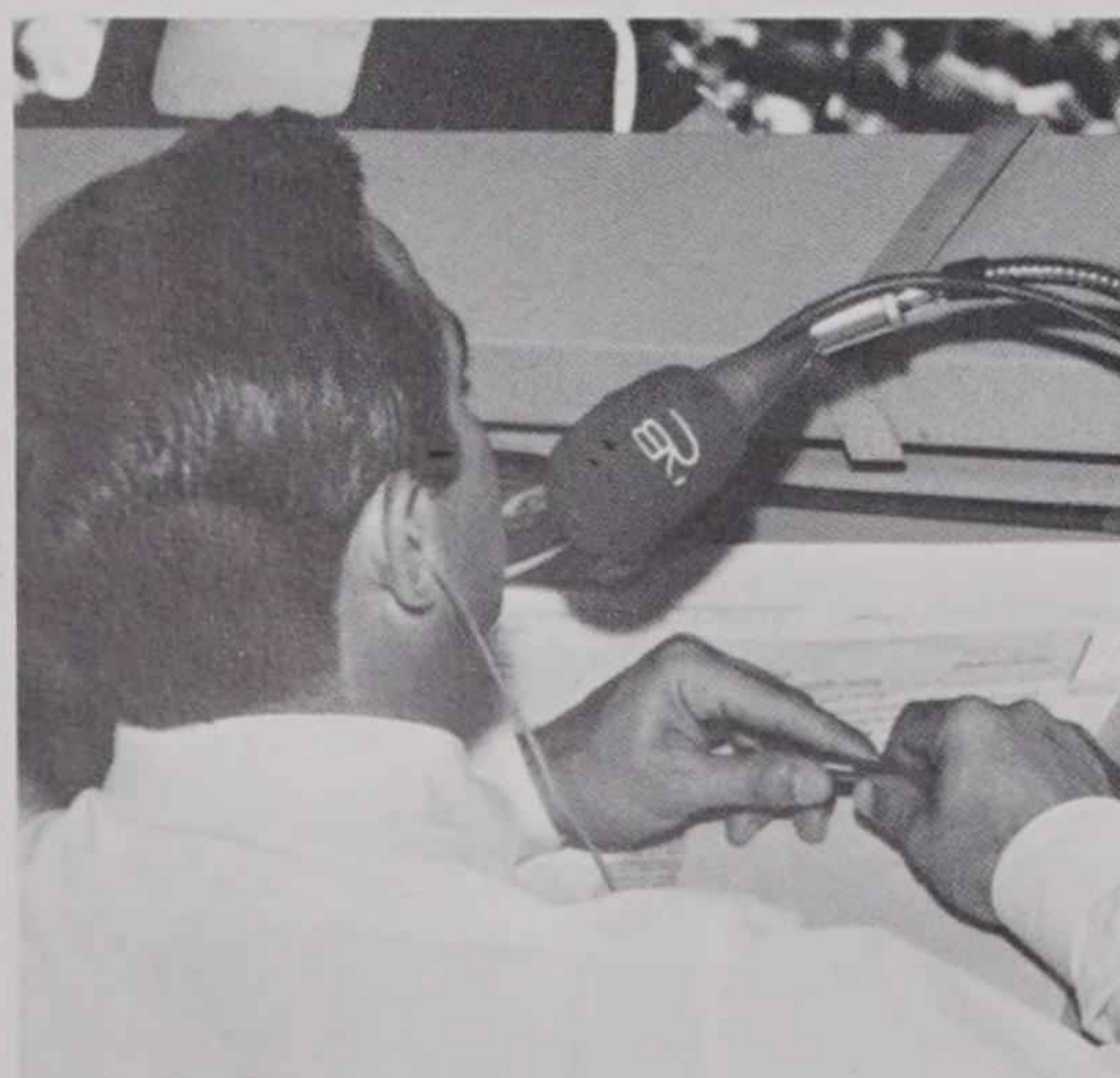

From the ice hockey rink to the baseball diamond, life in the world of sports has changed greatly in the last half-century. And nowhere has this change been more apparent than in the press box. New ball parks and arenas all over the country have meant new press boxes, and reporters and broadcasters have found themselves working not only in greater comfort but in comparative luxury.

For example, the plush press box at the Astrodome in Houston is equipped with upholstered chairs, built-in restroom facilities and two private elevators. On the other hand, some of the press boxes that were around when I broke in as a ballplayer were really dandies. The submarine-shaped one at the old Polo Grounds in New York was typical. It was a long metal cage that hung down in front of the upper deck. It had a tin roof, which made it just lovely on those hot, sunny days. And when the fans in the upper-deck box seats got excited, they'd let you know about it by beating their fists on the tin roof. It was like working in a bell tower at 12 o'clock.

The attitude of the sports writers has changed with their physical surroundings and not without reason. The biggest single factor has been a corresponding difference in the audience for which they are writing. In the old days, a reporter covered the game for a readership that didn't know who had won. Today, thanks to the prevalence of radio and television, the final score is usually stale news hours before the Sunday paper hits the newsstands Saturday night.

As a result, reporters dig more deeply into the personal lives of the players. It's a case of a writer saying to himself, "Since almost all of the readers will know that Willie Mays hit a home run today, my best chance of holding their interest is to tell them more about Willie." However, many ballplayers resent this intrusion into what they consider their private lives. A former New York Yankee pitcher, who had just won a tight ball game and become a father almost simultaneously, threw a fledgling newsman out of the locker room when questioned on his wife's theory of baby feeding rather than

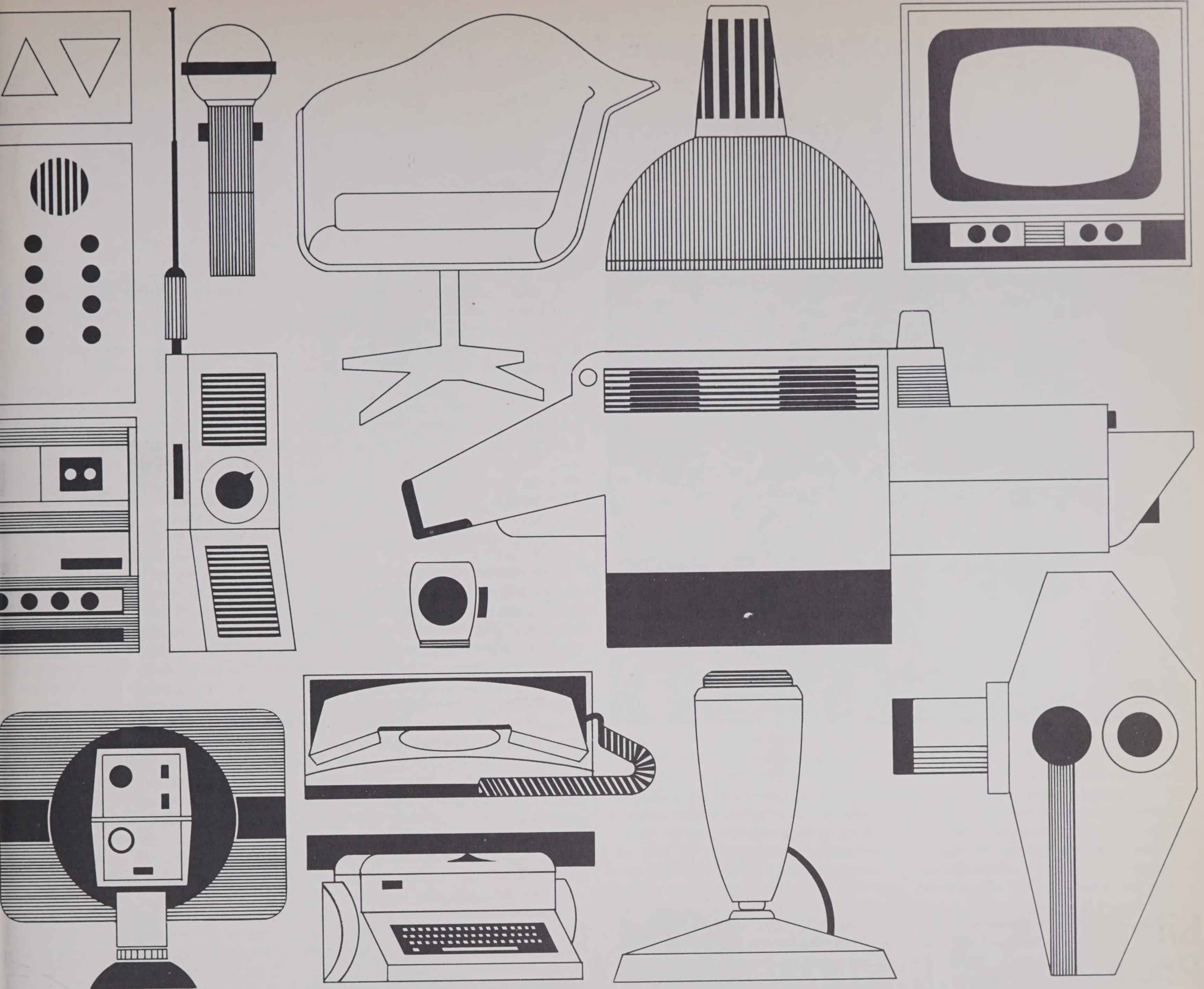

on the pitch he used to strike out the last batter. Today, the word "chipmunk" has become a euphemism for young reporters who dig for information outside the realm of batting averages and won-and-lost percentages.

This has resulted in coolness between athlete and writer. Present-day players keep themselves more aloof from the press than did the old-timers and are more wary about giving confidences. Another reason for the schism between reporters and athletes is the advent of the jet age. When baseball was a game that involved travel on overnight trains, players and reporters naturally spent more time in each other's company and became gin rummy and pinochle buddies.

In fact, today's writers sometimes are forced to live in almost a demilitarized zone with athletes. The needling from both sides can get rugged. A classic story concerns New York Jets quarterback Joe Namath who has had several brushes with the press. One day, during a group interview, one reporter asked "Broadway Joe," "What did you major in

at Alabama? Basketweaving?" Namath grinned slightly and answered, "No. I started with that but it was too tough, so I switched to journalism."

On the other hand, the late columnist Bugs Baer once commented on an unsuccessful try for a stolen base by lead-footed Ping Bodie of the Chicago Cubs by writing: "His heart was full of larceny, but his feet were honest." And Bob Cook, of the old New York *Herald-Tribune*, described the control troubles of Brooklyn Dodger hurler Rex Barney in these words: "If home plate was high and outside, Barney would go to the Hall of Fame." San Francisco Giants' relief pitchers have reacted none too kindly to a story by local newsman Charley Einstein. He once started off a report of a Giants' defeat in this way: "The Giants' latest winning streak — a red-hot one-straight — was ended tonight because something went wrong with the phones to both bullpens. Pittsburgh's didn't work. Ours did."

Reporters do not concentrate their barbs solely at the players; occasionally, they zero in on each other. A classic ex-

ample came many years ago when the New York *Daily News* assigned a young man to cover his first Yankee spring training season. Deciding that he wanted to attract some attention, he picked out as his special target second baseman Tony Lazzeri. Every day, he managed to find a way to make mention of his belief that Lazzeri, although still a young man, was washed up.

The day came when the Yankees won a spring training game on a grand-slam home run by Lazzeri. One reporter began his story, "In the fifth inning of yesterday's game, Tony Lazzeri hit a home run over the left-field fence, sending home Combs, Koenig, Muesel and the young man from the *Daily News*."

It was in this same press box, incidentally, that another legendary story was born. A young writer was seated next to veteran reporter Bill Slocum. Throughout the game, the youngster directed a barrage of elementary baseball questions at the older man, all of which were answered patiently. Finally, the game was over, and deadlines had to be met. Sud-

denly, Slocum felt a nudge. It was the youngster, who pointed toward the right-field fence and asked: "Bill, is that the West?" Slocum looked over the fence, where a big red sun was setting, and replied, "Son, if it's not, you've got one helluva story."

The biggest change in press box life occurred when the microphone began to share space with the typewriter. In the early days of radio, there were no broadcasting booths. Announcers and engineers sat among the spectators, but some colorful expressions from nearby fans soon made the move to the press box necessary.

The welcome given the broadcasters by the members of the press was somewhat less than cordial. Writers looked on announcers as interlopers and rivals, and even today there is coolness between the two media. Logic says that both media serve a definite purpose and usually complement each other, but logic is not always the deciding factor in an argument.

Years later, television heated up the feud. Because the announcer was seen

The telegrapher and sportswriter shared the open press box during the 1922 World Series.



as well as heard, he became a celebrity in his own right. He'd be asked for his autograph after a ball game, often while in the company of an unrecognized 20-year veteran of newspaper reporting. This did nothing to help their relationship.

In the days before television, the announcers not only had problems with writers but a keen rivalry with one another. There is the classic story of a radio reporter who was describing a brilliant run by a Notre Dame halfback that had begun on his own 20-yard line. By the time the runner was about 10 yards away from the goal line, the announcer realized that it was the quarterback who actually was carrying the ball. Nonplused, the announcer added a little extra excitement to his voice and shouted, "And now, Wyzinsky laterals to Higgins, and Higgins goes over for the touchdown." Since it was radio, he got away with it. Or thought he did. However, the late Ted Husing, one of the deans of sportscasting, heard the description, realized what had happened and just grinned.

The following spring, the same man who had broadcast the game was assigned to handle the Kentucky Derby. Running into Husing on the street, he asked Ted if he could offer any tips since the veteran had broadcast so many Derbies. Husing pointed out several things the man might look for and, in closing, added, "One more thing. Remember, you can't lateral a racehorse."

Speaking of covering a horse race, many fans wonder if racing writers bet on horses, and if so, how they manage to do it when they're way up in the press box. Both questions can be answered in one sentence. At most racetracks, there's a

pari-mutuel window right in the press box. I'd have to guess that, like most mutuel windows, it's a money-maker.

Of all the citizens in the press box, the ones who have seen the biggest change in their working conditions may be the photographers. In the old days, cameramen would snap a picture and then send the film and an accompanying caption card back to the office. There were two ways to do this. One was by a messenger who traveled by car, motorcycle, bus, subway or even bicycle. The other way was to put the negative and caption in a small container, which was then attached to the leg of a homing pigeon. Old-time photographers still laugh about how the pigeons would come flying out of the press box, circle the ball park, then perch on the roof to visit with some other pigeons. It was a little frustrating to a cameraman trying to make an edition.

That's all been changed. In some press boxes, a photographer can take a picture, develop and print it in an on-site darkroom, put it on a wirephoto machine connected to his office and never leave the press box. About the only problem that has stayed the same is the chance of the umpire standing between the camera and the play. Frustrated photographers can talk for hours on that subject.

In the old days, pigeons were allowed in the press box but women weren't. Not only were the ladies not welcome, but if they showed up — even on assignment from their newspapers — they were asked to leave. That eventually changed, not by actions of newsmen but because Western Union assigned women to the press box as telegraph operators. Since a story was no good if it didn't reach the

paper, complaints were held to a minimum, and, today, women are found in most press boxes.

The press box might very well be one of the biggest tributes to the power of the press. Ball clubs build press boxes, service press boxes and even own press boxes, but they don't control them. At a baseball game, anyone who sits in the press box does so only with the approval of the Baseball Writers' Association of America, which has chapters in every major league city. It is the local chapter chairman who is responsible for accreditation, and even the club owner cannot overrule him.

In fact, over the years, several club owners have found that their authority ended when they walked into their own press boxes. Larry MacPhail, when he was operating the Brooklyn Dodgers, visited the press box in Ebbets Field and became very loud in his criticism of the umpiring. Sitting in the press box that day was Bill Klem, who had been a great ball-and-strike arbitrator and was then serving as supervisor of umpires for the National League. A great friend of the press, Klem was always welcome in any press box.

As MacPhail's complaints against the men in blue became louder, he suddenly found himself overmatched by the booming voice of Klem. The umpire looked right at the club president and boomed, "You, sir, are an applehead." MacPhail turned around for support, found only laughter and quietly left.

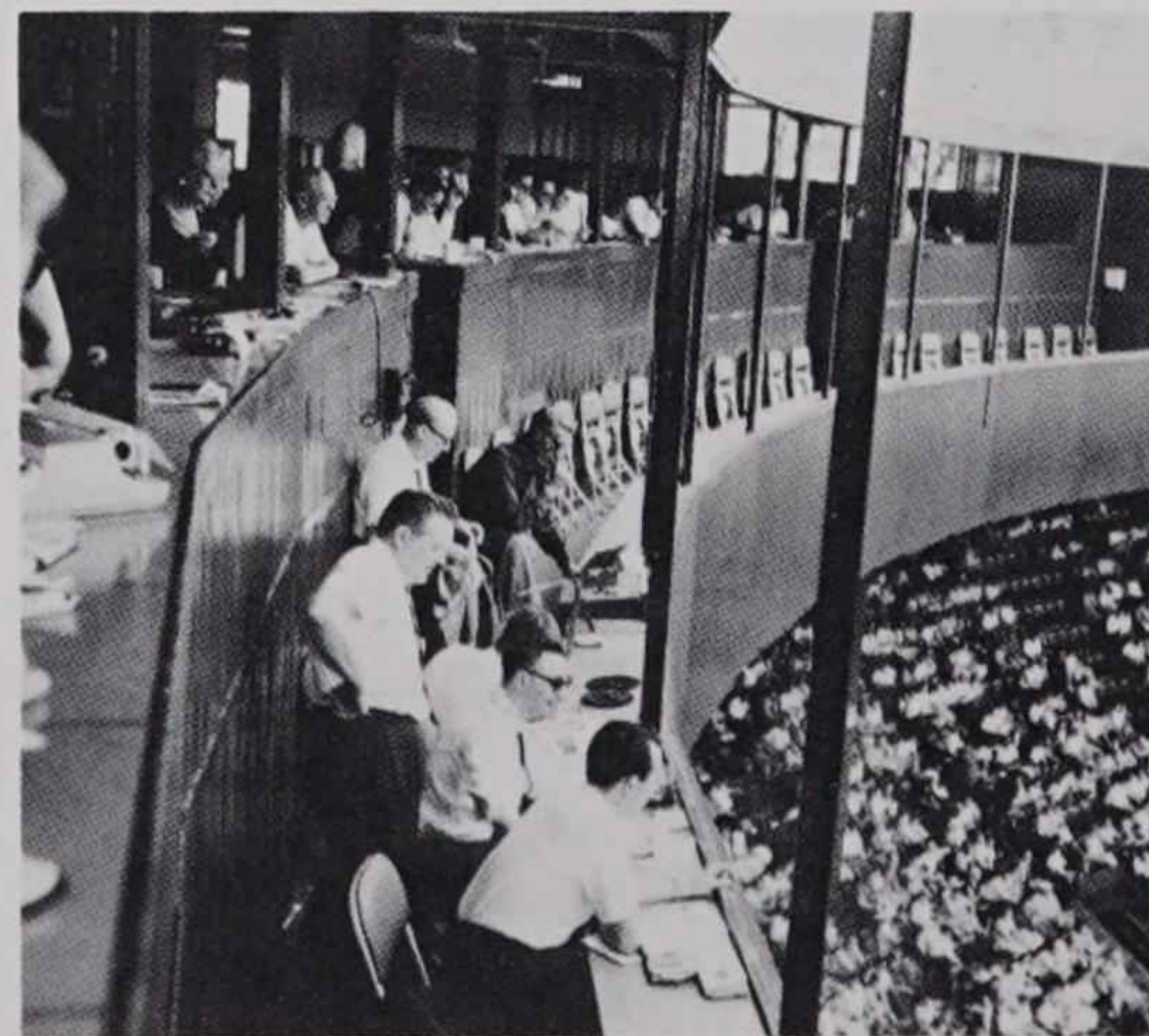

Press box in Detroit's Tiger Stadium.

On another occasion, MacPhail loudly berated a New York newspaperman, Red Patterson, for a story he had written for the *Herald-Tribune*. Patterson answered in kind, and, before long, the two men were wrestling on the floor of the press box. When it was finally broken up, MacPhail found himself being ordered out of his own press box. He went.

This autonomy of the press box dates back to an incident that took place during the 1908 World Series between the Detroit Tigers and the Chicago Cubs. In Chicago, the press box was wide open, and

thus an inviting place to perch for anyone who didn't have a regular seat. When reporter Hugh Fullerton arrived to take his seat, he found it occupied by an actor named Louis Mann. When Mann refused to move, the newsman simply sat down in his lap and covered the game from that position. As soon as the World Series was over, the writers met in Detroit to form their Association.

The press box, like any working environment, has had its share of people with different approaches to their jobs. There were writers who would arrive at the ball park at about the eighth inning of a game, sit down next to a fellow reporter and say "catch me up." All the latecomer wanted was a play-by-play account of everything that had happened.

The broadcasting booth has had its share of characters, too. One day in the Polo Grounds, Frank Frisch and his partner were doing a play-by-play account of a fairly dull mid-season game. At the middle of the fifth inning, Frank's partner excused himself. Frisch nodded, figuring the other man was going to the rest room. Frisch wasn't quite correct. His partner was going to Birmingham, Ala. He had become fed up with his job, and that was the time he picked to go home.

Another change in the press box and broadcasting booth is that both have become increasingly crowded. There was a time when, except for newspapers, coverage of a World Series was handled by a single telegrapher. He would sit in the press box and tap out a play-by-play account of the game. This would be passed across the country to newspaper offices, where huge signs would be erected on the outsides of buildings, and people would stand in the street to follow the progress of the game.

In contrast, NBC had 95 employees at the ball park for its radio and television coverage of the 1968 World Series. Instead of one telegraph key, NBC had eight color cameras covering plays on the field. And to cover the celebration in the clubhouse after the final game, there were another color camera, one videograph, and two video-tape and two slow-motion machines.

Life in the press box has become more comfortable for the writer, the broadcaster, the telecaster and the photographer. But the pressure has become a little tougher, since their audiences today are larger and better informed. Progress has its price, and the citizens of the press box are learning that every year it gets tougher and tougher to lateral a racehorse. ■

Books at Random...

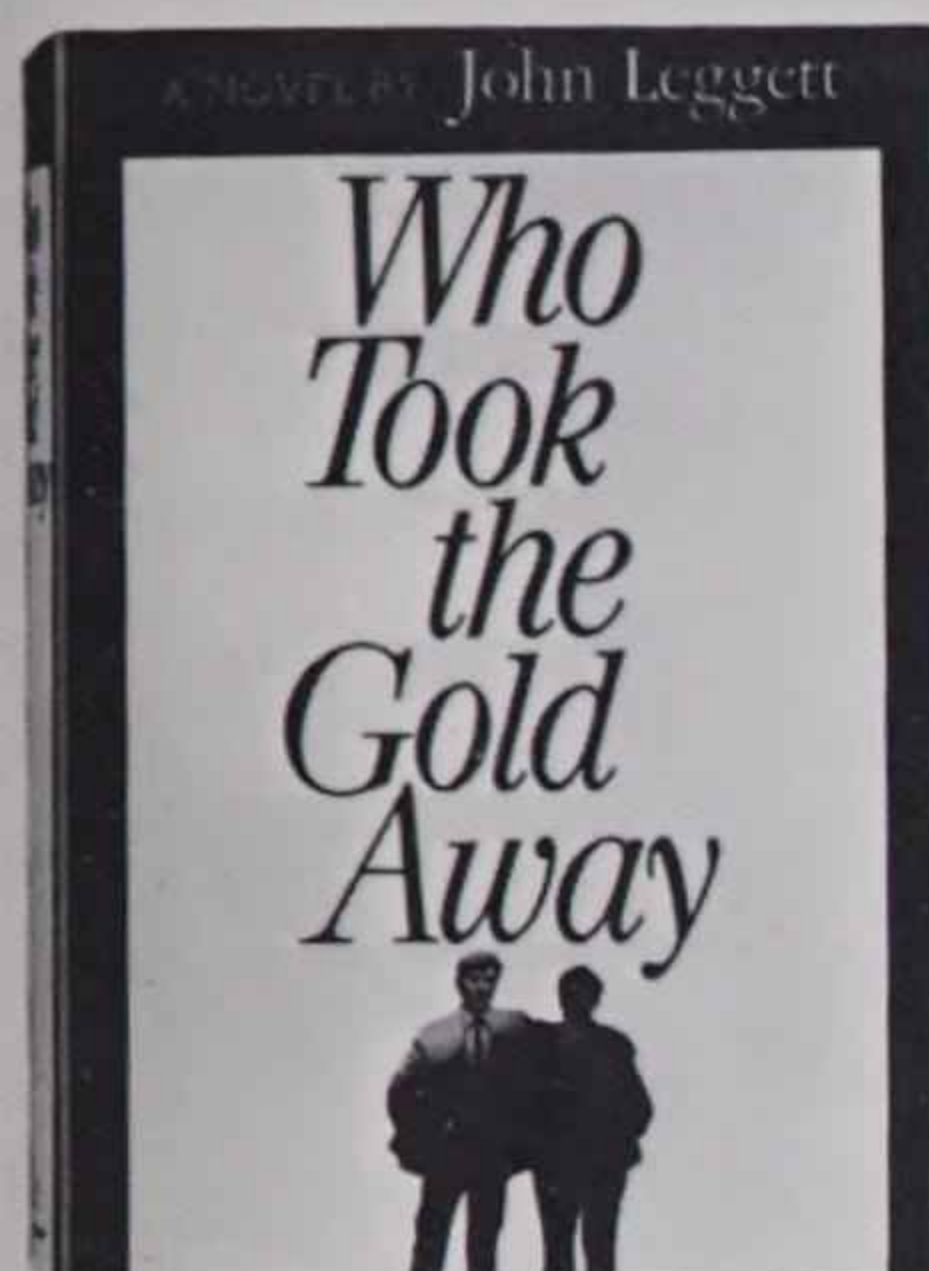

Who Took the Gold Away
by John Leggett (Random House)

The setting of John Leggett's third novel moves from New Haven to Newport to Cambridge, and the story that unfolds is of a deep and complex friendship between two men, Pierce Jay and Benjamin Moseley. They meet at Yale in 1938 as freshmen; Pierce has come from a series of Eastern preparatory schools while Ben, a scholarship student, has arrived from a public high school. Their friendship is founded on their separate strengths and failings rather than on a common bond. For more than 20 years, through their loves, marriages and business endeavors, there is a mutual admiration between them — but there is also envy and even a will to destroy each other.

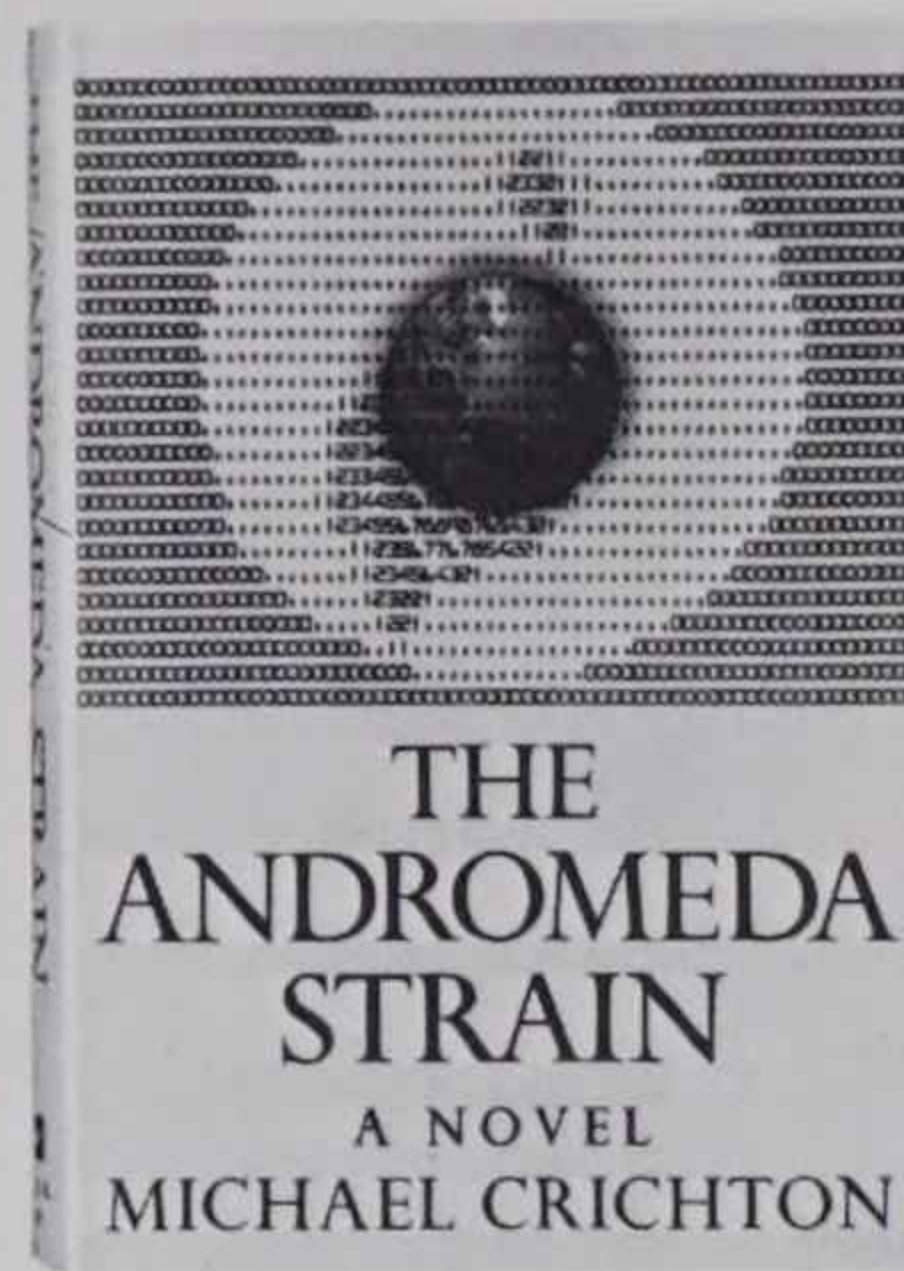

The Andromeda Strain
by Michael Crichton (Alfred A. Knopf)

Space-age exploration carries with it the terrifying possibility that contact with new and virulent life forms in the unknown may be beyond man's ability to survive. In this novel of the world's first space-age biological crisis, an unmanned research satellite returns to earth mysteriously and lethally contaminated. Crichton projects what situations may result and recounts them with documentary reality. The frantic mission of "Project Wildfire" involves the crash mobilization of the nation's highest scientific and medical resources in an effort to end the plague. It is an unforgettable vision of a future that could become the present.

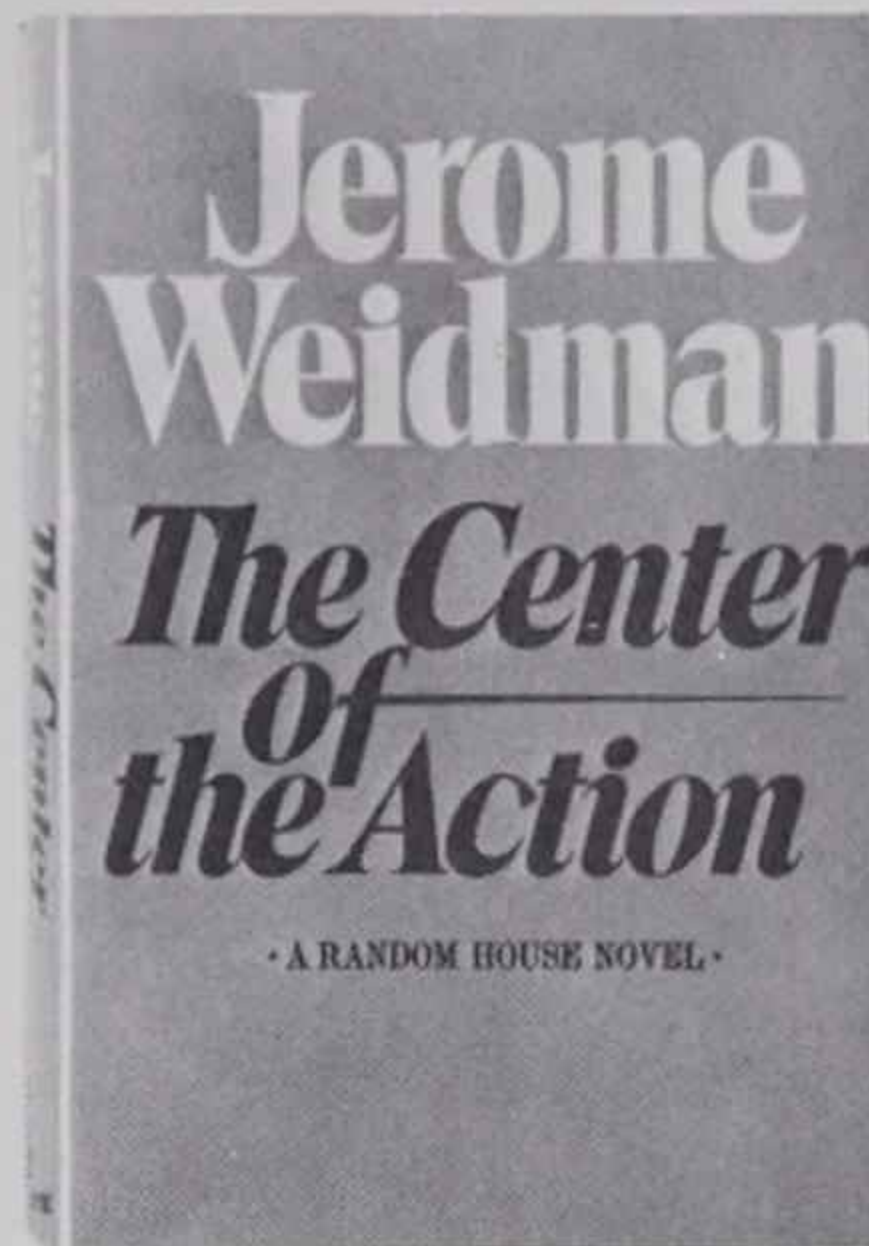

The Center of the Action
by Jerome Weidman (Random House)

In this novel, Mr. Weidman explores the current American passion for business mergers by examining, in humorous and often terrifying detail, the takeover of an old-style publishing house by a new-style financial wizard. From the moment Ted Leff, fresh from the garment center, walks into the offices of Mattlin and Merritt, he begins to apply the methods of the Seventh Avenue "rags business" to the problems of Fourth Avenue's Publishers' Row and makes a fortune in the process. He saves Mattlin and Merritt from a financial disaster. Ultimately, he gains control of the firm by methods sometimes frowned upon by the district attorney's office.

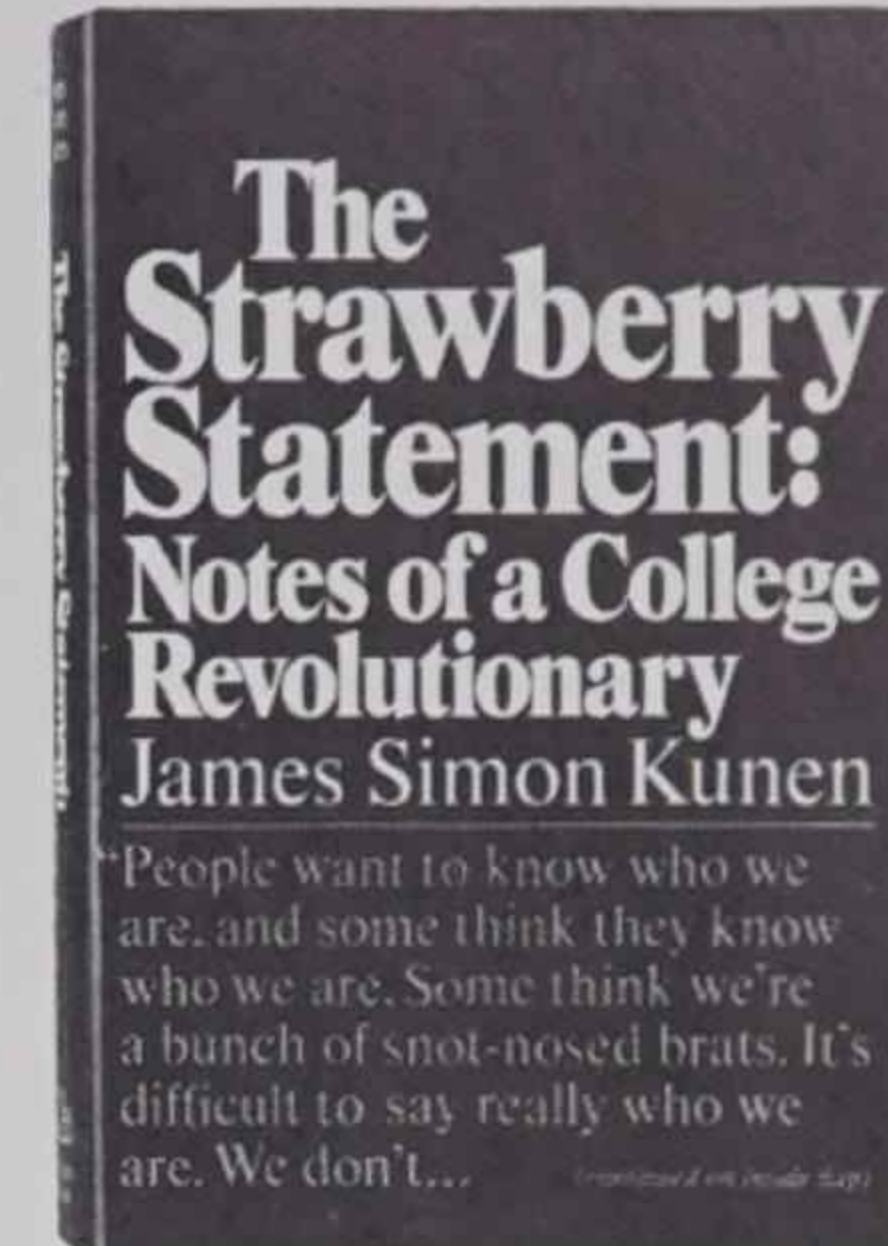

The Strawberry Statement: Notes of a College Revolutionary
by James Simon Kunen (Random House)

A participant in the 1968 Columbia University disturbances, the 19-year-old student-author jotted down his eyewitness accounts of and personal observations about what was happening around him. In diary-like entries, the author talks about himself, his girlfriend Laura, another revolutionist, and his daily activities. ("Wednesday, June 19: I went to Washington, D.C., for the rich people's march in support of the Poor People's Campaign. You are supposed to come away from these affairs with a renewed commitment and sense of purpose. I came away with two girls' addresses and a slight tan.")



The Same Only Different
by Margaret Webster (Alfred A. Knopf)

One hundred and fifty years of English and American theater come alive in this account of a great theatrical family that has been at the center of the stage for five generations. A famous actress-director, Miss Webster begins the theatrical history of her family with the first Ben Webster who fathered 11 acting and dancing children. His son, "Old Ben," a great comic actor, collaborated with Dickens and Bulwer-Lytton and was the leading theatrical manager of his day. Miss Webster's famous parents, "Young Ben" and Dame May Whitty, together with such colleagues as Ellen Terry, the Barrymores and George Bernard Shaw dominate the second part of the book.

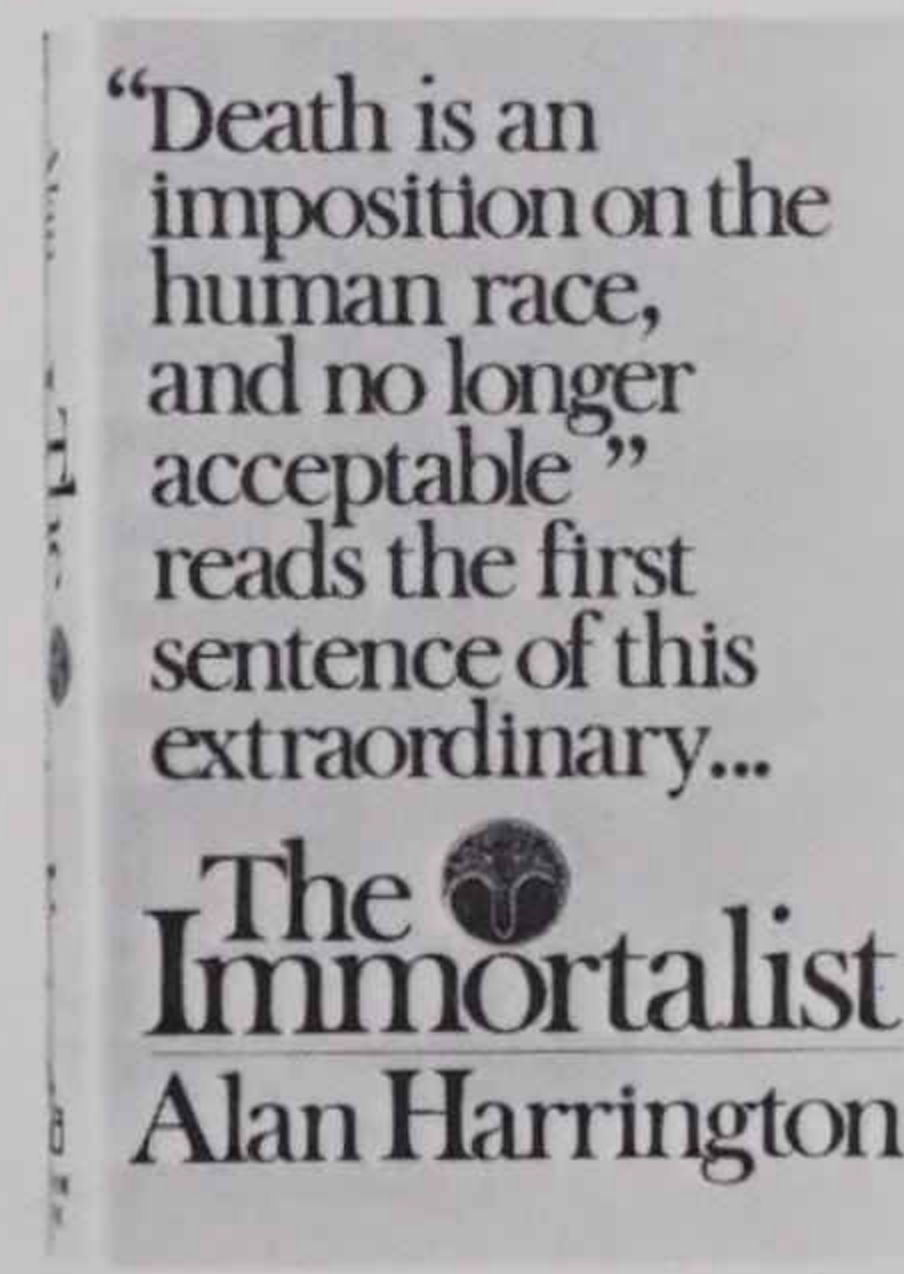

The Immortalist
by Alan Harrington (Random House)

"Death is an imposition on the human race, and no longer acceptable" reads the first sentence of this thoughtful and scientifically documented work. Mr. Harrington's premise is simple and rational: If mankind can conquer plagues and the atom, why not death? His thesis is that the time has come for man to get rid of the intimidating gods in his own head. He argues that man must believe that, with the new technology we will soon have at our disposal, death eventually can be conquered; salvation belongs to medical engineering; freedom from death will come only by science, not by prayer; and our only messiahs will be wearing white coats and working in laboratories.

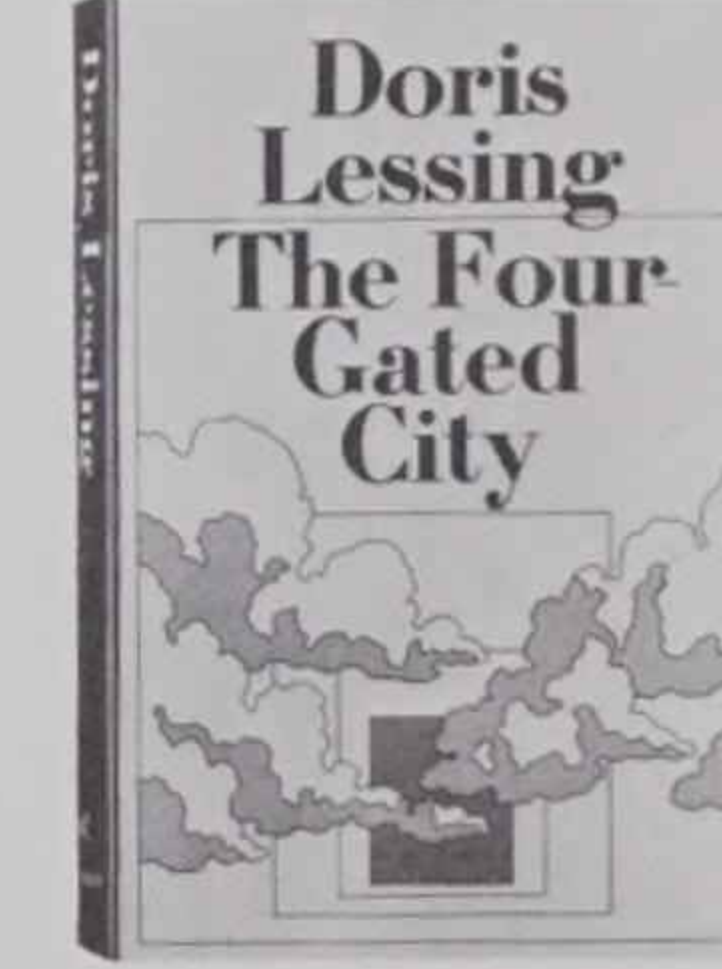
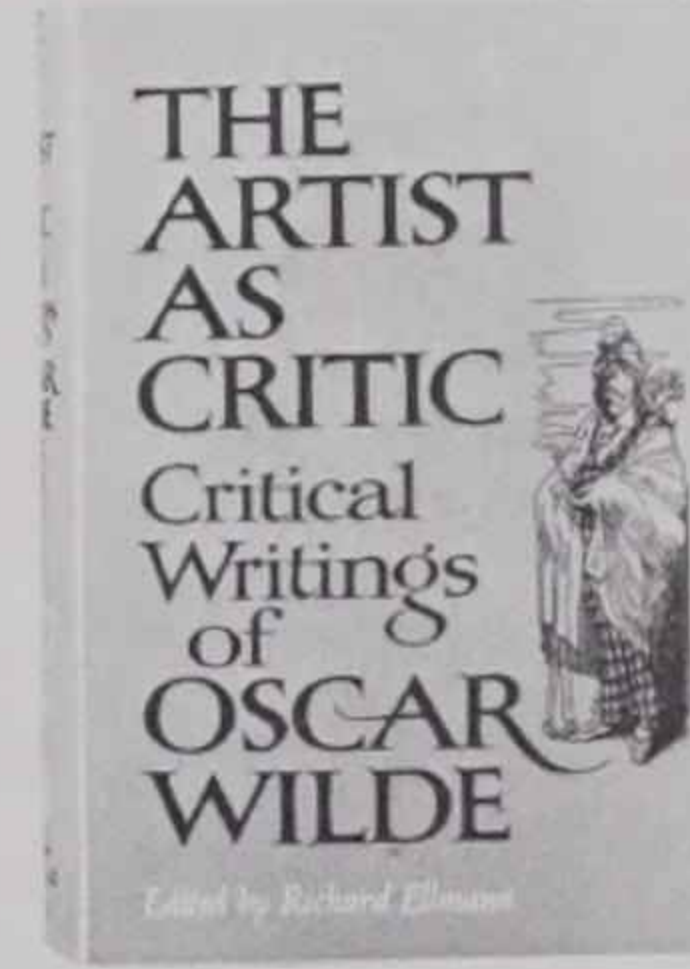
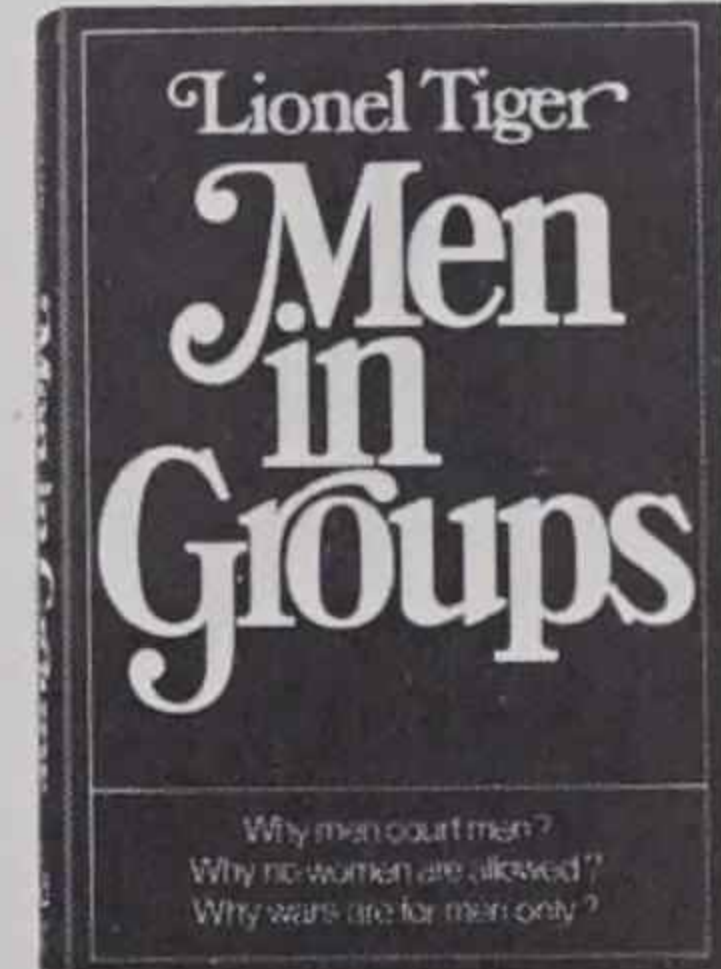

Other Recent Random House Books

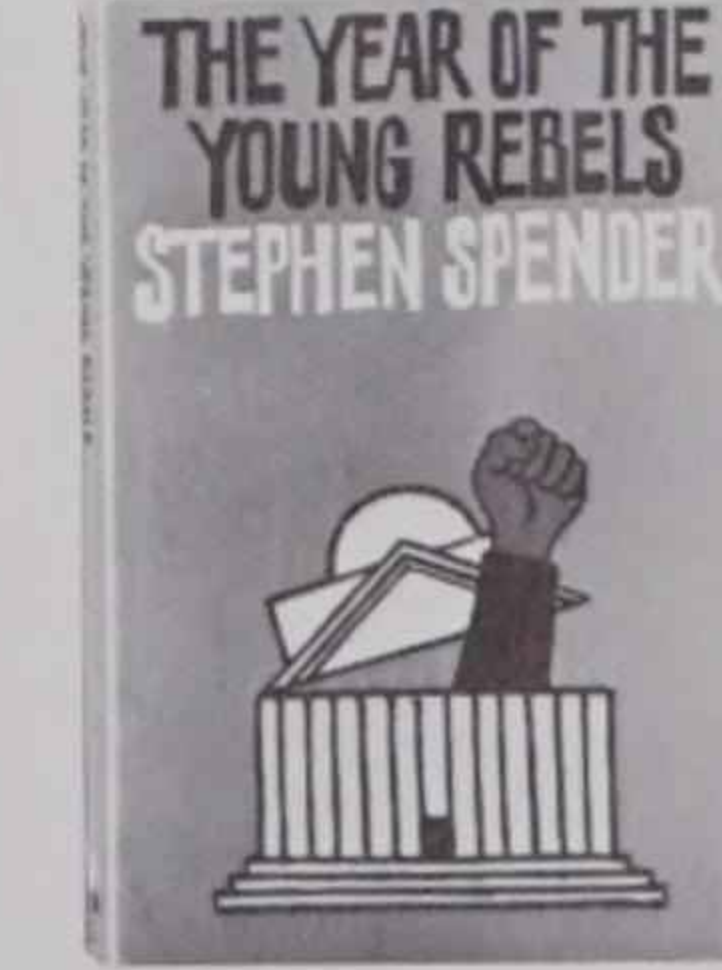
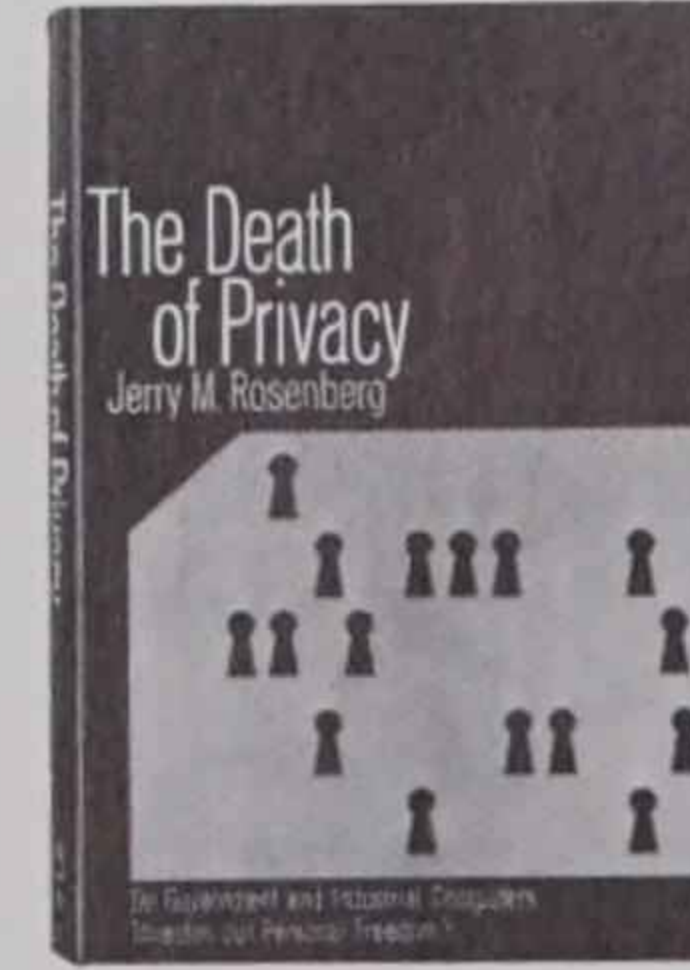
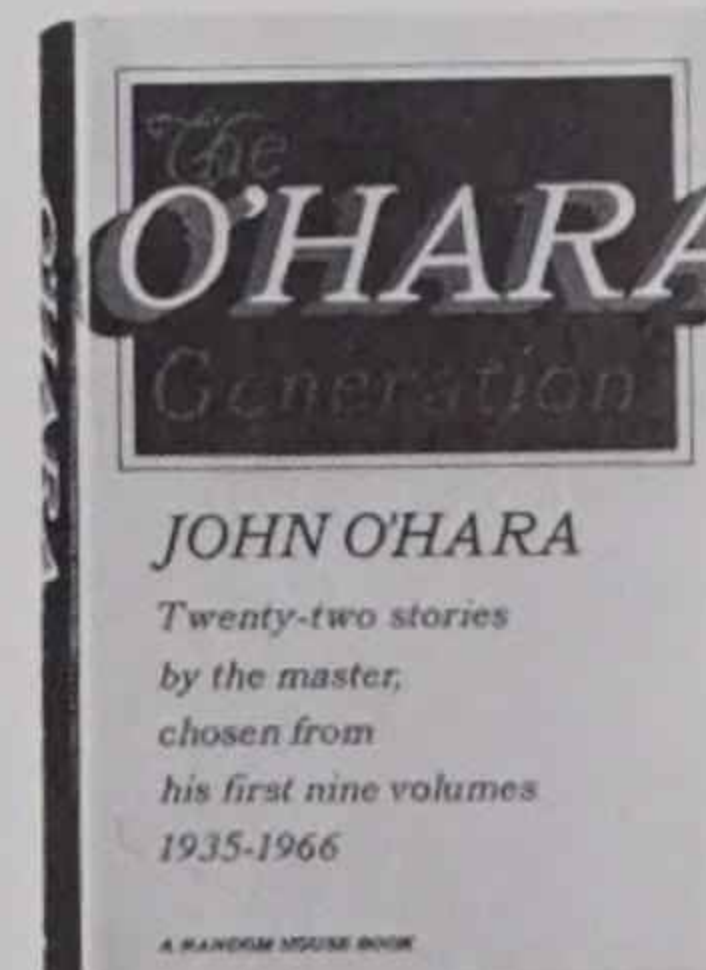

Electronically Speaking...

News in Brief of Current Developments in Electronics

Laser Scanner Will Protect Tomorrow's High-Speed Trains

An experimental laser track inspector designed as a safety aid for trains of the future that may travel at speeds of 300 to 500 miles an hour has been developed for the U.S. Department of Transportation. The device, which sweeps the railroad track with laser light beams to detect foreign objects as small as a walnut, has been demonstrated successfully on a section of track near Princeton, N.J.

The RCA laser scanner is part of the Transportation Department's investigation into high-speed train systems that could relieve congestion in regional areas such as the Northeast Corridor, which extends from Boston to Washington. This study covers such concepts as a 500-mile-an-hour vehicle that would ride on a cushion of air over a guideway roadbed in the late 1970s and '80s.

At these ultrahigh speeds, even a small rock on the roadbed could cause damage. Emergency stops must be virtually eliminated, since it would require several miles to bring a train to a halt. If a stop is absolutely necessary, then considerable advance warning would have to be given to the crew.

In operation, a series of laser devices could provide complete coverage of the roadbed. They have been designed to operate in a wide variety of weather conditions without sounding false alarms or missing an object. Should a rock or tree limb obstruct the roadbed, the laser would detect it and signal a central facility so that it could be removed before it hindered a train. The central facility also could transmit an advance warning to an approaching train to stop if the object could not be removed in time.

Electronic Stockbroker Obeys Buy-and-Sell Orders

A robot stockbroker, programmed with a limited Wall Street vocabulary, can be trained to recognize the voice of any stockholder and obey his commands. The stockbroker is an experimental RCA data-processing system comprised of a time-sharing computer, a TV data terminal and special electronic circuits that can analyze human speech.

Typical commands would be customer requests that the system display a listing of their current holdings or buy or sell selected shares and then update and display the revised portfolio. The system is even programmed not to carry out illegal commands such as selling more stock than a customer owns.

Though other computer systems that respond to vocal commands have been developed, they have all been dedicated

(non-time-sharing) systems able to use only one vocabulary and, in order to do their job, have had to process more than 3,000 bits of information a second.

By contrast, the experimental RCA system shares time on a computer with 31 other users and can be adapted to handle any vocabulary ranging from the vernacular of the stock exchange to the language of space flight. The system requires only 120 bits of information a second to perform its tasks.

A vocabulary of some 28 words of importance in the brokerage field is typed into the memory of the time-sharing computer by means of a standard data terminal keyboard. Starting with this as a base, the computer goes into a training mode and, through its video display, asks the user to say each word into a microphone. The microphone, in turn, is linked to circuits that analyze each spoken word according to a dozen critical acoustical features that are converted to digital electronic patterns and sent to the computer's memory for storage. This process is repeated an average of three times for each word, or until the computer is satisfied that it can recognize the word when the user says it. After that, the computer is switched to the automatic mode and is ready to accept verbal instructions from its trainer.

Someday, similar speech recognition systems may automate production equipment, operate airplanes and space vehicles, retrieve information from a central data bank and make possible automated mail-order retailing.

New VIDEOCOMP System Sets Line Drawings as Well as Type

The first all-electronic composition system that can set line drawings as well as graphic-arts quality type and do it in either full-page-size or on microfilm has been developed. The new RCA VIDEOCOMP system sets type faster than can 1,000 manual linecasters and writes a full-page line drawing in less than seven seconds.

This equipment is not restricted to the publishing and printing industries. Engineering departments will be able to store, retrieve and print out drawings in microfilm form. Marketing people will get sales projections in chart form. The same basic information used for data processing can be used to produce illustrated catalogs, parts and service manuals, directories and reports that require frequent updating and broad distribution.

Transatlantic Link for Investors

European investors now have instant access to Wall Street via a new voice-

record circuit — a total system that can accommodate all major forms of communication including voice, high-speed data, telegraph and facsimile.

The circuit is being used by Merrill Lynch, Pierce, Fenner and Smith to link its main office in New York with its European headquarters in Geneva, Switzerland, which in turn feeds data to its 14 offices on the continent. This direct channel means that overseas customers of the brokerage firm can place an order to buy or sell shares on the New York and American Stock Exchanges and within seconds receive a confirmation that the order has been placed. In addition, they can query a Merrill Lynch computer in Manhattan and obtain an opinion almost instantaneously on any one of 3,500 stocks.

Computers and other electronic equipment connected to the RCA circuit also will be utilized to transmit to all European offices various forms of data, including the company's business sheet. This information was previously airmailed to Europe and delays up to 10 days were common.

The circuit is capable of simultaneously transmitting computer-produced data at 3,000 words a minute and handling communications over 12 teleprinter channels at speeds up to 100 words a minute.

Hot Line for Businessmen

A private hot line for businessmen has been put into operation between New York City and San Juan. It will allow an executive in his Manhattan office to establish immediate contact with his associate in Puerto Rico merely by lifting the handset on his telephone, eliminating the time-consuming chore of placing calls through switchboards or dialing long numerical sequences.

In addition to voice transmission, the hot line also can accommodate various forms of high-speed data communications. Information input/output devices such as computer data terminals, teleprinters and equipment for transmitting facsimile material can be interconnected to the system by pushing a button on the telephone.

The new voice/data service utilizes up to six desktop telephones. One phone serves as the master station, with push-button controls to switch from voice to data mode or to make a connection on any or all hot line extensions. There is also a priority telephone extension on the desk of the company's chief executive, which permits him to preempt the circuit for voice conversation that cannot be monitored by anyone else.

The system, operated by RCA Global

Communications, Inc., may be extended to other major overseas points in the near future.

Battlefield Communications by Means of Satellite

Small, portable ground stations that permit a soldier in combat to establish an instant communications link with his headquarters command via satellite have been built for the Tactical Satellite Communications (TACSATCOM) program, a joint effort of the armed forces.

The small size and versatility of the five new RCA units contrast sharply with the large ground stations normally associated with communications satellite systems. One of the units is light enough to be carried by one man. Another can be carried by three men and be set up and in operation within 15 minutes. There are also a jeep-mounted unit; a shelter unit transportable by truck, plane or helicopter; and an airborne version. Except for the "listen only" one-man set, these stations are capable of two-way voice communication. The jeep, shelter and airborne units also can handle printed messages.

Eventually, the TACSATCOM system will be capable of simultaneously handling large numbers of calls or messages over long distances by providing a single-point relay between military elements.

Photo and illustration credits: cover, Erich Hartmann for RCA; page 2, cartoon from *Krokodil*; page 4 (left) N. Pashin—Sovfoto, (middle) N. Selyuchenko—Sovfoto, (right) Y. Pashina—Sovfoto; page 5 (left) V. Mastuykov—Sovfoto, (right) Eve Arnold—Magnum; page 6 (left) E. Yevzherikhin—Sovfoto, (middle) TASS from Sovfoto, (right) Erich Lessing—Magnum; page 7, A. Zhigailov—Sovfoto; pages 8 and 9, American Heritage Publishing Co., Inc.; pages 12 and 13, Bell Telephone Laboratories; page 14, Studio International; page 15 (left) The Boeing Company, (right) Studio International; page 17 (top) The Bettmann Archive, Inc., (bottom) Constance Bannister; pages 18 and 19, Warren Flagler; pages 22 and 23, montage elements from Federal Aviation Administration, American Airlines, British Overseas Airways Corporation and The Boeing Company; pages 24, 25 and 26, Lockheed Aircraft Corporation; page 27, Pan American World Airways; pages 28 and 29, Tom Cook of RCA; pages 32 and 33, illustration by Barry Ross; page 34 (left) Brown Brothers, (right) *The Sporting News*; inside back cover, California Computer Products, Inc.

The Snail, created by programmer Kerry Strand. An article on "Art and the Computer" begins on page 12.

RCA

Electronic Age

Summer

