

SEPTEMBER

1970  
ONE DOLLAR

# Whole Earth Catalog

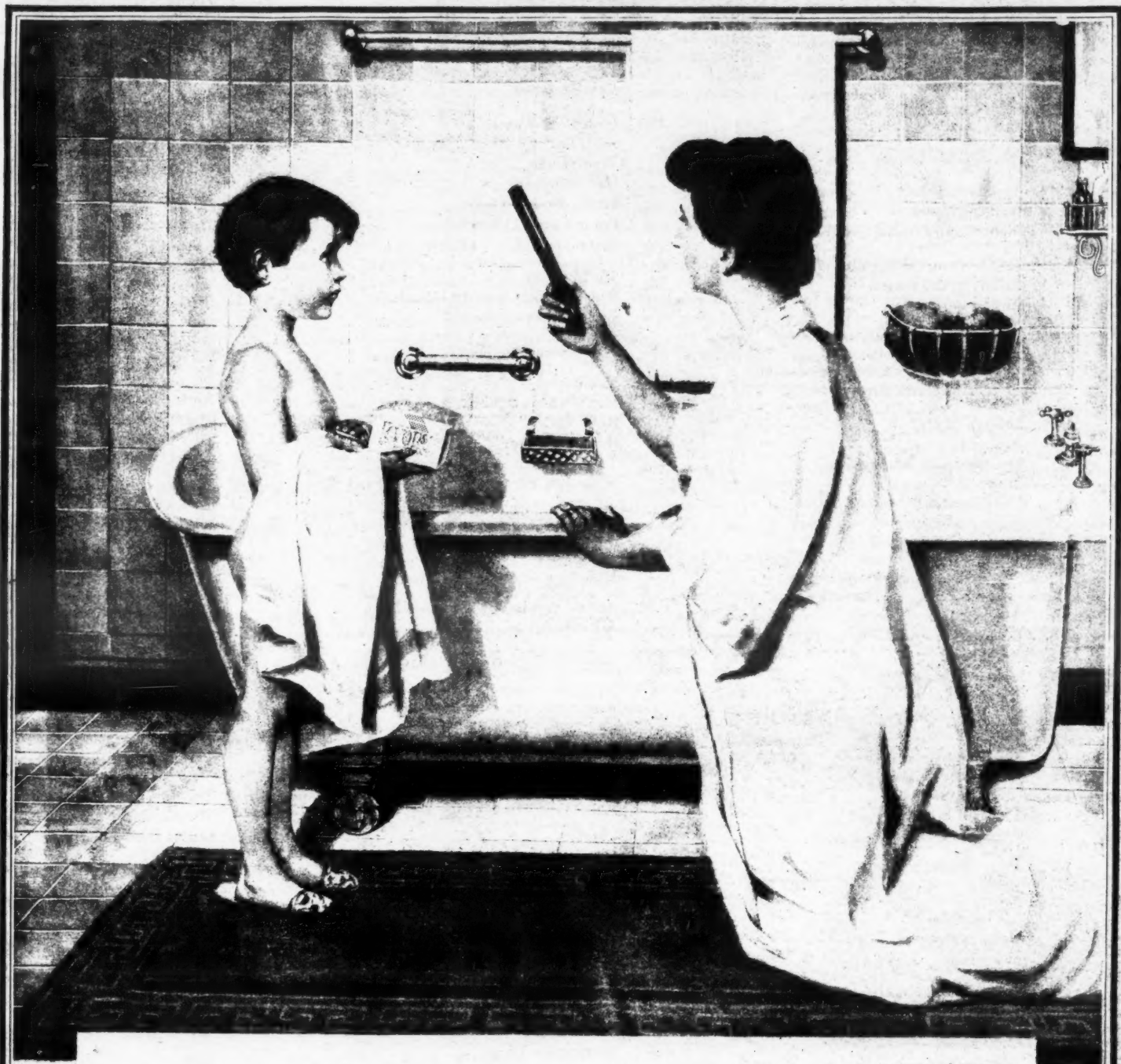

"I don't want to. I DON'T WANT TO.  
I don't want to be a MAN; I want to be a Fox."

— Indian Tales

*See page 45*

# Whole Earth Catalog

September / 1970

- |    |   |    |  |
|----|---|----|--|
| 3  | Think Little  |    |  |
| 4  | Jarfalla: City of the Future  |    |  |
| 5  | Manifesto   |    |  |
| 6  | Harlan and Anna Hubbard<br>Friends on the Farm  | 23 | Codpieces<br>Swedish Milk Cups   |
| 7  | Maine Times   | 24 | Summer in Fort Resolution  |
| 8  | Mining on Kirk's Creek  | 25 | Japan, Hong Kong, Australia<br>Catalán Earth   |
| 9  | Rabbits   | 26 | Irish Folk Ways<br>Announcing: Australian WEC<br>Tree Seeds?<br>Hand Husker?<br>Memo From Paradise<br>Peace Corps Defended<br>Summer Digs                                |
| 10 | The Have-More Plan  | 27 | World Game<br>World Design Science Decade<br>Buddhist Economics  |
| 11 | Hensley Settlement  | 28 | A Chairmaker at Work   |
| 12 | Appalachia<br>Stinking Creek<br>Night Comes to the Cumberlands  | 30 | Remember—<br>Useful Odds & Ends<br>Root Beer<br>Hand Washers<br>To Dry Corn<br>Write For Free Directions   |
| 13 | Seedtime on the Cumberland<br>Cabins in the Laurel<br>On Heroes   | 31 | Violin Repairing From Breugel<br>Compost for the City<br>Yogurt<br>Jerk It   |
| 14 | Letters from Prison   | 32 | A Two Pendulum Drawing Engine<br>A Birch Bark Crib   |
| 15 | Mining on Kirk's Creek (continued)<br>Pioneer Superstitions   | 33 | How To Build A Lipton Kickwheel  |
| 16 | Beware of HyLab<br>Sudbury<br>Craftsman vs. Woodcraft<br>Trapped Us<br>More on Aladdin<br>Sense and Patience<br>Hughes is Swamped<br>BBC<br>Alaska Sleeping Bag Co.   | 34 | Ham—<br>Radical Software<br>—Com   |
| 17 | We All Agree<br>Japanese Saws<br>Hatches<br>Molasses Man Found<br>Found: Harold Bate<br>Northwest Looms—Well Worth It<br>Oh Dear<br>Music Synthesizers<br>Miscellaneous<br>Crunch, Crunch<br>Vitamin E<br>Algae As Food | 35 | Canadian Whole Earth Almanac<br>Human Biocomputer<br>Boy Scout Merit Badge Series  |
| 18 | Life, Death, Karma<br>Babies At Home: A Calculated Risk   | 36 | J.D.'s Insect-Food Bug<br>The American Bison<br>Memories, Dreams, Reflections<br>Embroidery Stitches<br>Speed vs. Time<br>Swimming Pools As Reservoirs                   |
| 19 | It's Important<br>From Newsweek<br>Our Final Culture  | 37 | Correspondence Schools<br>Progressive Colleges?<br>Apprenticeship Program<br>Trailer Life<br>Homemade Harps<br>Vermont   |
| 20 | How to use an ax, or . . .<br>It Was 50 Years Ago, Today<br>The Motherhood Myth   | 38 | Appalachian Mountain Club<br>This & That<br>Saving The Soil<br>Whale Songs<br>Money, Honey<br>Ah, The Army<br>Composter In The Sky<br>Shine With Soda                    |
| 21 | Women In Communes<br>From Sara<br>Sources for Info, Materials, Groups   | 39 | Reflections, Post-Liferaft Earth<br>The Latest Inflatables<br>Re: Quick Hard Summary<br>For Scroungers<br>Let The Sun Shine In<br>New NASA Photos<br>Plastic Possibility |
| 22 | Diana's Rap<br>From Phyllis<br>From rgw   | 40 | Notes from Alaska<br>Australia & Immigration<br>Juicy Item   |
|    |   | 41 | Do It!<br>Tips<br>Knives<br>Eureka "Draw Tite" Tents<br>Yarns<br>Vegetarianism<br>Sailing, Sailing<br>More Good Soap<br>The Record Man                                   |
|    |   | 42 | An Indian Bibliography<br>The American Heritage Book of Indians<br>Two Treasures<br>Curtis' Western Indians  |
|    |   | 43 | The Teachings of Don Juan<br>Book of the Hopi<br>Black Elk Speaks  |
|    |   | 44 | The Peyote Cult<br>The Rock Paintings of the Chumash<br>Ishi In Two Worlds<br>Indian Tales   |
|    |   | 45 | Zuni Breadstuff<br>Hunters of the Northern Ice   |
|    |   | 46 | 3 By Eastlake<br>Little Big Man<br>America Needs Indians!<br>American Indian Prose and Poetry  |
|    |   | 47 | The Bark Canoes and Skin Boats<br>The Indian in America's Past<br>Custer Died For Your Sins  |
|    |   | 48 | Catalog Procedure  |
|    |   | 49 | Function<br>Purpose<br>Sustaining & Retaining Subscribers  |
|    |   | 50 | Spring '70 Catalog Corrections   |
|    |   | 51 | Fall '69 Catalog Corrections<br>An Alright Wheelwright Book  |
|    |   | 52 | Staff<br>Introducing: Divine Right's Bus, Urge   |
|    |   | 53 | Business   |
|    |   | 54 | Whole Earth Truck Store  |
|    |   | 55 | Portola Institute  |

## CONTENTS

© 1970 Portola Institute

All rights reserved under Pan-American and International copyright conventions.

# Think Little

by Wendell Berry

First there was Civil Rights, and then there was The War, and now it is The Environment. The first two of this sequence of causes have already risen to the top of page one of the nation's consciousness, and declined somewhat, in a remarkably short time. I mention this in order to begin with what I believe to be a justifiable skepticism. For it seems to me that the Civil Rights Movement and the Peace Movement, as popular causes in the electronic age, have partaken far too much of the nature of fads. Not for all, certainly, but for too many they have been the fashionable politics of the moment. As causes they have been undertaken too much in ignorance; they have been too much simplified; they have been powered too much by impatience and guilt of conscience and short-term enthusiasm, and too little by an authentic social vision and long-term conviction and deliberation. For most people those causes have remained almost entirely abstract; there has been too little personal involvement, too much involvement in organizations which were insisting that other organizations should do what was right.

There is considerable danger that the Environment Movement will have the same nature: that it will be a public cause, served by organizations that will self-righteously criticize and condemn other organizations, inflated for a while by a lot of public talk in the media, only to be replaced in its turn by another fashionable crisis. I hope that will not happen, and I believe that there are ways to keep it from happening, but I know that if this effort is carried on solely as a public cause—if millions of people cannot or will not undertake it as a *private* cause as well—then it is *sure* to happen. In five years the energy of our present concern will have petered out in a series of public gestures—and no doubt in a series of empty laws—and a great, and perhaps the last, human opportunity will have been lost.

It need not be that way. A better possibility is that the movement to preserve the environment will be seen to be, not a digression from the civil rights and peace movements, but the logical culmination of those movements. For I believe that the separation of these three problems is artificial. They have, it seems to me, the same cause, and that is the mentality of greed and exploitation. The mentality that exploits and destroys the natural environment is the same that abuses racial and economic minorities, that imposes on young men the tyranny of the military draft, that makes war against peasants and women and children with the indifference of technology. The mentality that destroys a watershed and then panics at the threat of flood is the same mentality that gives institutionalized insult to black people and then panics at the prospect of race riots. It is the same mentality that can mount deliberate warfare against a civilian population and then express moral shock at the logical consequence of such warfare at My Lai. We would be fools, in my opinion, to believe that we could solve any one of these problems without solving the others.

To me, one of the most important aspects of the environmental movement is that it brings us not just to another public crisis, but to a crisis of the protest movement itself. For the environmental crisis should make it dramatically clear, as perhaps it has not always been before, that there is no public crisis that is not also private. To most advocates of civil rights racism has seemed mostly the fault of someone else. For most advocates of peace the war has been a remote reality, and the burden of the blame has seemed to rest mostly on the government. I am certain that these crises have been more private, and that we have each suffered more from them and been more responsible for them, than has been readily apparent, but the connections have been difficult for most of us to see. Racism and militarism have been institutionalized among us for too long for our personal involvement in those evils to be easily noticeable to us. Think, for example, of all the Northerners who assumed—until black people attempted to move into *their* neighborhoods—that racism was a Southern phenomenon. And think how quickly—one might almost say how naturally—among some of its members the peace movement has spawned policies of deliberate provocation and violence.

But the environmental crisis rises closer to home. Every time we draw a breath, every time we drink a glass of water, every time we eat a bite of food we are suffering from it. And more important, every time we indulge in, or depend on, the wastefulness of our economy—and our economy's first principle is waste—we are *causing* the crisis. Nearly every one of us, nearly every day of his life is contributing *directly* to the ruin of this planet.

In this crisis it is certain that every one of us has a public responsibility. We must not cease to bother the government and the other institutions, to see that they never become comfortable with easy promises. For myself, I want to say

that I hope never again to go to Frankfort to present a petition to the governor on an issue so vital as that of strip mining, only to be dealt with by some ignorant functionary—as several of us were not so long ago, the governor himself being “too busy” to receive us. Next time I will go prepared to wait as long as necessary to see that the petitioners' complaints and their arguments are heard *fully* by the Governor. And then I will hope to find ways to keep those complaints and arguments from being forgotten until something is done to relieve them. The time is clearly past when it was enough merely to *elect* our officials. I think we will have to elect them and then go and *watch* them and keep our hands on them, the way the coal companies do. We have made a tradition in Kentucky of putting mediocrities and freeloaders, and worse, in charge of our vital interests. I am sick of it. And I think that one way to change it is to make Frankfort a less comfortable place. As I have said before, and intend to say again, I believe in American political principles, and I will not sit idly by and see those principles destroyed by sorry practice. I am ashamed and deeply distressed that American government should have become the chief cause of disillusionment with American principles.

And so when the government in Frankfort again proves too stupid or too blind or too corrupt to see the plain truth and to act with simple decency, I intend to be there, and I trust that I won't be alone. I hope, moreover, to be there, not with a sign or a slogan or a button, but with the facts and arguments. A crowd whose discontent has risen no higher than the level of slogans is *only* a crowd. But a crowd that understands the reasons for its discontent and knows the remedies is a vital community, and it will have to be reckoned with. I would rather go before the government with two men who have a competent understanding of an issue, and who therefore *deserve* a hearing, than to go with two thousand who are vaguely dissatisfied.

But even the most articulate public protest is not enough. We don't live in the government or in institutions or in our public utterances and acts, and the environmental crisis has its roots in our *lives*. By the same token, environmental health will also be rooted in our lives. That is, I take it, simply a fact, and in the light of it we can see how superficial and foolish we would be to think that we could correct what is wrong merely by tinkering with the institutional machinery. The changes that are required are fundamental changes in the way we are living.

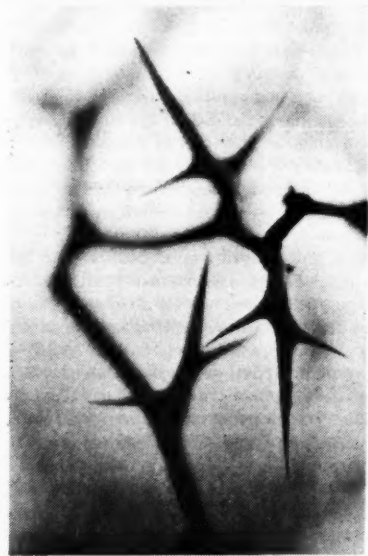

What it seems to me that we are up against in this country, in any attempt to invoke private responsibility, is that we have nearly destroyed private life. Our people have given up their independence in return mostly for the cheap seductions and the shoddy merchandise of so-called “affluence.” We have delegated all our vital functions and responsibilities to salesmen and agents and bureaus and experts of all sorts. We cannot feed or clothe ourselves, or entertain ourselves, or communicate with each other, or be charitable or neighborly or loving, or even respect ourselves, without recourse to a merchant or a corporation or a public service organization or an agency of the government or a style-setter. Most of us cannot think of dissenting from the opinions or the actions of one organization without first forming a new organization. Individualism is going around these days in uniform, handing out the party line on individualism. Dissenters want to publish their personal opinions over a thousand signatures. →

# Think Little

Confucius says that the "chief way for the production of wealth" (and he is talking about real goods, not money) is "that the producers be many and that the mere consumers be few. . . ." But even in the much-publicized rebellion of the young against the materialism of the affluent society, the consumer mentality is still intact: the standards of behavior are still those of kind and quantity, the security sought is still the security of numbers, and the chief motive is still the consumer's anxiety that one is missing out on what is "in." In this state of total consumerism—which is to say a state of helpless dependence on things and services and ideas and motives that we have forgotten how to provide ourselves—all meaningful contact between ourselves and the earth has been broken. We do not understand the earth either in terms of what it offers us or what it requires of us, and I think it is the rule that people inevitably destroy what they do not understand. Most of us are not directly responsible for strip mining and extractive agriculture and other forms of environmental abuse. But we are guilty nevertheless, for we connive in them by our ignorance. We do not know enough about them; we do not have a particular enough sense of their damage. Most of us not only do not know how to produce the best food in the best way—we don't know how to produce food of any kind in any way. And for this condition we have elaborate rationalizations, instructing us that dependence for everything on somebody else is efficient and economical and a scientific miracle. I say, instead, that it is pure madness, mass produced. A man who understands the weather only in terms of golf is participating in a chronic public insanity that either he or his descendants will be bound to realize as suffering. I believe that the death of the world is breeding in such minds "much more certainly and much faster than in any political capital or atomic arsenal.

For an index of our loss of contact with the earth we need only to look at the condition of the American farmer—who must in our society, as in every society, enact man's dependence on the land, and his responsibility to it. In an age of unparalleled affluence and leisure, the American farmer is harder pressed and harder worked than ever before; his margin of profit is small, his hours long; his outlays for land and equipment and the expenses of maintenance and operation are growing rapidly greater; he cannot compete with industry for labor; he is being forced more and more to depend on the use of destructive chemicals and on the wasteful methods of haste and anxiety. As a class, farmers are one of the despised minorities. So far as I can see farming is considered marginal or incidental to the economy of the country, and farmers, when they are thought of at all, are thought of as hicks and yokels, whose lives do not fit into the modern scene. The average American farmer is now an old man, whose sons have moved away to the cities. His knowledge, and his intimate connection with the land are about to be lost. The small independent farmer is going the way of the small independent craftsmen and storekeepers. He is being forced off the land into the cities, his place taken by absentee owners, corporations, and machines. Some would justify all this in the name of efficiency. As I see it, it is an enormous social and economic and cultural blunder. For the small farmers who lived on their farms *cared* about their land. And given their established connections to their land—which was often hereditary and traditional as well as economic—they could have been encouraged to care for it more competently than they have so far. The corporations and machines that replace them will never be bound to the land by the sense of birthright and continuity and love which enforces care. They will be bound by the rule of efficiency which takes thought only of the volume of the year's produce, and takes no thought of the slow increment of the life of the land, not measurable in pounds or dollars, which will assure the livelihood and the health of the coming generations.

If we are to hope to correct our abuses of each other and of other races and of our land, and if our effort to correct these abuses is to be more than a political fad that will in the long run be only another form of abuse, then we are going to have to go far beyond public protest and political action. We are going to have to rebuild the substance and the integrity of private life in this country. We are going to have to gather up the fragments of knowledge and responsibility that we have parceled out to the bureaus and the corporations and the specialists, and we are going to have to put those fragments back together again in our own minds and in our families and households and neighbor-

hoods. We need better government, no doubt about it. But we also need better minds, better friendships, better marriages, better communities. We need persons and households that do not need to wait upon organizations but who can make necessary changes in themselves, on their own.

For most of the history of this country our motto, implied or spoken, has been THINK BIG. I have come to believe that a better motto, and an essential one now, is THINK LITTLE. That implies the necessary change of thinking and feeling, and suggests the necessary work. Thinking Big has led us to the two biggest and cheapest political dodges of our time: plan-making and law-making. We have been carried clean away on the wings of great gold-plated polit-



ical and economic generalizations. The lotus-eaters of this era are in Washington, D.C., Thinking Big. Somebody comes up with a problem, and somebody in the government comes up with a plan or a law. The result, mostly, has been the persistence of the problem, and the enlargement and enrichment of the government.

But the discipline of thought is not generalization; it is detail, and it is personal action. While the government is "studying" and funding and organizing its Big Thought, nothing is being done. But the citizen who is willing to think little, and, accepting the discipline of that, to go ahead on his own, is already solving the problem. A man who is trying to live as a neighbor to his neighbors will have a lively and practical understanding of the work of peace and brotherhood, and—let there be no mistake about it—he is *doing* that work. A couple who make a good marriage, and raise healthy, morally-competent children are serving the world's future more directly and surely than any political leader, though they never utter a public word. A good farmer who is dealing with the problem of soil erosion on an acre of ground has a sounder grasp of that problem, and *cares* more about it, and is probably doing more to solve it than any bureaucrat who is talking about it in general. A man who is willing to undertake the discipline and the difficulty of mending his own ways is worth more to the conservation movement than a hundred who are insisting merely that the government and the industries mend *their* ways.

If you are concerned about the proliferation of trash, then by all means start an organization in your community to do something about it. But before—and while—you organize, pick up some cans and bottles yourself. That way, at least, you will assure yourself and others that you mean what you say. If you are concerned about air pollution, help push for government controls, but drive your car less, use less fuel in your home. If you are worried about the damming of wilderness rivers, join the Sierra Club, write to

## Jarfalla: City of the Future

STOCKHOLM—The first city of the future will be built in Sweden. It will be called Jarfalla, have about 100,000 residents, and be accessible by subway or highway from Stockholm, just 12 miles away. No gasoline-powered vehicle will be allowed. Noiseless electric minibuses moving at a soothing 20 miles per hour will pass within 150 yards of everyone's house, carrying passengers and baggage free. Rolling platforms something like horizontal escalators will carry downtown shoppers on their rounds, underground heating will melt snow as it falls to the sidewalks, garbage will be collected by vacuums installed in each residence and transported through tunnels by compressed air to incinerators 30 miles away. Heat and hot water will be supplied by a single thermonuclear plant, the temperatures regulated by individual thermostats. The air will be pure, the smog-free light dazzling, the water delicious and wholesome, the streets impeccable, the only sounds those of music and children at play. It will cost an enormous amount of money.

Alas, we cannot be all Swedes, nor can all Swedes live in Jarfalla. By the time there are 7 billion of us milling around the planet, 30 years from now—or 9 billion, 20 or 30 years from now—our lives are likely to be arranged quite differently. Futurologists hold out a considerable range of repellent prospects.

Among the most cheerful is Nigel Calder, former editor of *New Science* in England, whose ideas go something like this:

Those of us still living on land may be enclosed in anything from towns of 50,000 completely under glass to supercities of 50 million commanding nearly a million square miles—the size of Western Europe. But the majority of the human race will be settled on the sea, in floating towns reaching deep under water so that disturbance due to surface winds and waves—seasickness, that is—will be negligible. More likely than not, these towns will take the form of iceships, ice being unsinkable, easily landscapable, and relatively cheap to make and preserve (one doesn't like to think of a possible power failure, but Mr. Calder assures us we needn't worry). The icetowns would be protected against wind by geodetic domes, perfumed and decorated by thoughtfully contrived sights and sounds, air-conditioned to a year-round spring-like temperature, and supplied with food by ocean gardens grown either on imported soil or in enclosed and cultivated tanks of sea water.

Limited as such nourishment may be to the palate, we might go down on our knees in gratitude for it, considering the possible alternatives. About 4 or 5 billion people would be facing starvation, few of us could permit ourselves the luxury of real fruit and vegetables (a cucumber, say, or a watermelon). Scientists having discovered that yeast can be grown on petroleum, vast quantities of this cheap protein source can be grown to feed animals destined in turn to feed us. Three main production lines for animal protein would then operate side by side.

In one, cattle, pigs and poultry would be raised on plant material for meat and eggs. In another, milk would be formed continuously by a culture of milk-producing glands, intended for drinking and making butter and cheese. In a third, beef muscle would grow continuously in long tubes, extruding itself for chopping into steaklike portions. A complex of smaller works would turn out a selection of prepared foods—soups, sausage, bread, beer and so on—for national or regional distribution. Vitamins and flavors from national suppliers would be added as required. Orange and lemon juice could be produced from cultures, with chemical processing of fibrous materials to add "bite." The very rich could buy natural fruit and vegetables from millionaire market-gardeners; the very poor could sustain life with combinations of plant and yeast material reinforced with vitamins—comparable, perhaps, to having all of one's meals supplied by a domestic airline, with vitamins added.

Mr. Calder does not go very deeply into the psychological side-effect of all this.

If the effects on human beings may not be altogether foreseeable, we are already getting some idea of what may happen to the animals we'll be counting on, nutritionally speaking. The latest method of pig-raising, for instance, already makes use of the production line, the pigs arrayed in rows before conveyor belts moving at a carefully calculated pace with carefully dosed food rations designed for optimum fattening at minimum cost. The one hitch is an inclination on the pig's part to go crazy; thus, the otherwise automated system requires a highly paid attendant whose only function is to watch for early symptoms of insanity and snatch the unfortunate patient from his place at the conveyor belt, replacing him with another identical in appearance, within five minutes at most, before all the rest go wild.

—Times/Post News Service

the government, but turn off the lights you're not using, don't install an air conditioner, don't be a sucker for electrical gadgets, don't waste water. In other words, if you are fearful of the destruction of the environment, then learn to quit being an environmental parasite. We all are, in one way or another, and the remedies are not always obvious, though they certainly will always be difficult. They require a new kind of life—harder, more laborious, poorer in luxuries, but also, I am certain, richer in meaning and more abundant in real pleasure. To have a healthy environment we will all have to give up things we like; we will probably have to give up things we have come to think of as necessities. But to be fearful of the disease and yet unwilling to pay for the cure is not just to be hypocritical; it is to be doomed. If you talk a good line without being changed by what you say, then you are not just hypocritical and doomed; you have become an agent of the disease. Consider, for an example, the President, who advertises his grave concern about the destruction of the environment, and who turns up the air conditioner to make it cool enough to build a fire.

Odd as I am sure it will appear to some, I can think of no better form of personal involvement in the cure of the environment than that of gardening. A person who is growing a garden, if he is growing it organically, is improving a piece of the world. He is producing something to eat, which makes him somewhat independent of the grocery business, but he is also enlarging, for himself, the meaning of food and the pleasure of eating. The food he grows will be fresher, more nutritious, less contaminated by poisons and preservatives and dyes. He is reducing the trash problem; a garden is not a disposable container, and it will digest and re-use its own wastes. If he enjoys working in his garden, then he is less dependent on an automobile or merchant for his pleasure. He is involving himself directly in the work of feeding people.

If you think I'm wandering off the subject, let me remind

Wendell Berry's newest book of poems, *Farming: A Hand Book*, has just been published by Harcourt, Brace and Jovanovich. The *Hidden Wound*, a book-length essay about racism, will be published by Houghton-Mifflin late this fall.

Think Little was originally presented as an Earth-Day speech last April. It was previously published in blue-tail fly, a Kentucky underground newspaper.

blue-tail fly  
210 W. Third St.  
Lexington, Ky. 40507

Published monthly, 25 cents a copy

Photos accompanying *Think Little* by James Baker Hall.

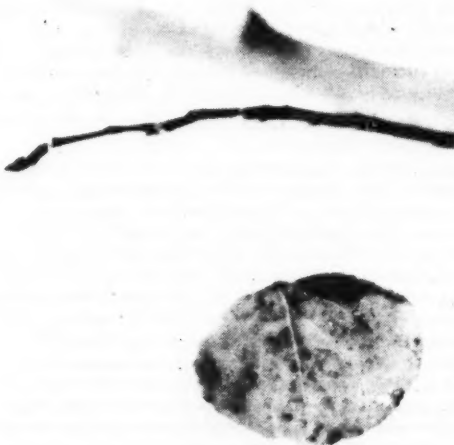

you that most of the vegetables necessary for a family of four can be grown on a plot of forty by sixty feet. I think we might see in this an economic potential of considerable importance, since we now appear to be facing the possibility of widespread famine. How much food could be grown in the dooryards of cities and suburbs? How much could be grown along the extravagant rights-of-ways of the Interstate system? Or how much could be grown, by the intensive practices and economics of the small farm, on so-called marginal lands? Louis Bromfield liked to point out that the people of France survived crisis after crisis because they were a nation of gardeners, who in times of want turned with great skill to their own small plots of ground. And F.H. King, an agriculture professor who traveled extensively in the Orient in 1907, talked to a Chinese farmer who supported a family of twelve, "one donkey, one cow, . . . and two pigs on 2.5 acres of cultivated land"—and who did this, moreover, by agricultural methods that were sound enough organically to have maintained his land in prime fertility during several thousand years of such use. These are possibilities that are very readily apparent and attractive to minds that are prepared to think little. To Big Thinkers—the bureaucrats and businessmen of agriculture—they are quite simply invisible. But intensive, organic agriculture kept the farms of the Orient thriving for thousands of years, whereas extensive—which is to say, exploitive or extractive—agriculture has critically reduced the fertility of American farmlands in a few centuries or even a few decades.

A person who undertakes to grow a garden at home, by practices which will preserve rather than exploit the economy of the soil, has set his mind decisively against what is wrong with us. He is helping himself in a way that dignifies him, and which he will find to be rich in meaning and pleasure. But he is doing something else that is more important: he is making vital contact with the soil and the weather on which his life depends. He will no longer look upon rain as an impediment of traffic, or upon the sun as a holiday decoration. And his sense of man's dependence on the world will have grown precise enough, one would hope, to be politically clarifying and useful.

What I am saying is that if we apply our minds directly and competently to the needs of the earth, then we will have begun to make fundamental and very necessary changes in our minds. We will begin to understand and to mistrust and to change our wasteful economy, which markets not just the produce of the earth, but also the earth's ability to produce. We will see that beauty and utility are alike dependent upon the health of the world. But we will also see through the fads and the fashions of protest. We will see that war and oppression and pollution are not separate issues, but are aspects of the same issue. Amid the outcries for the liberation of this group or that, we will know that no person is free except in the freedom of other persons, and that man's only real freedom is to know and faithfully occupy his place—a much humbler place than we have been taught to think—in the order of creation. And we will know that of all issues in education the issue of relevance is the phoniest. If life were as predictable and small as the talkers of politics would have it, then relevance would be a consideration. But life—as the earth itself will teach us, if we let it—is large and surprising and mysterious, and we don't know what we need to know. When I was a student I refused certain subjects because I thought they were irrelevant to the duties of a writer, and I have had to take them up, clumsily and late, to understand my duties as a man. What we need in education is not relevance, but abundance, variety, adventurousness, thoroughness. A student should suppose that he needs to learn everything he can, and he should suppose that he will need to know much more than he can learn.

But the change of mind I am talking about involves not just a change of knowledge, but also a change of attitude toward our essential ignorance, a change in our bearing in the face of mystery. The principle of ecology, if we will take it to heart, should keep us aware that our lives depend upon other lives and upon processes and energies in an interlocking system which, though we can destroy it completely, we can neither fully understand nor fully control. And our great dangerousness is that, locked in our selfish and myopic economics, we have been willing to change or destroy far beyond our power to understand. We are not humble enough or reverent enough.

Some time ago I heard a representative of a paper company refer to conservation as a "no-return investment." This man's thinking was almost exclusively oriented to the annual profit of his industry. Circumscribed by the demand that profit be great, he simply could not be answerable to any

other demand—not even to the obvious needs of his own children. The principle of profit applies only to individuals; a man willing to be governed by it has abdicated, not the duty, but the ability to look beyond himself.

Consider, in contrast, the profound ecological intelligence of Black Elk, "a holy man of the Oglala Sioux," who in telling his story said that it was not his own life that was important to him, but what he had shared with all life:

It is the story of all life that is holy and is good to tell, and of us two-leggeds sharing in it with the four-leggeds and the wings of the air and all green things. . .

And in the great vision that came to him when he was a child he says:

I saw that the sacred hoop of my people was one of many hoops that made one circle, wide as daylight and as starlight, and in the center grew one mighty flowering tree to shelter all children of one mother and one father. And I saw that it was holy.



#### MANIFESTO: THE MAD FARMER LIBERATION FRONT

For Jack and Mary Jo

Love the quick profit, the annual raise, vacation with pay. Want more of everything ready made. Be afraid to know your neighbors and to die. And you will have a window in your head. Not even your future will be a mystery any more. Your mind will be punched in a card and shut away in a little drawer. When they want you to buy something they will call you. When they want you to die for profit they will let you know. So, friends, every day do something that won't compute. Love the Lord. Love the world. Work for nothing. Take all that you have and be poor. Love someone who does not deserve it. Denounce the government and embrace the flag. Hope to live in that free republic for which it stands. Give your approval to all you cannot understand. Praise ignorance, for what man has not encountered he has not destroyed. Ask the questions that have no answers. Invest in the millennium. Plant sequoias. Say that your main crop is the forest that you did not plant and that you will not live to harvest. Say that the leaves are harvested when they have rotted into the mold. Call that profit. Prophesy such returns. Put your faith in the two inches of humus that will build under the trees every thousand years. Listen to carrion—put your ear close, and hear the faint chattering of the songs that are to come. Expect the end of the world. Laugh. Laughter is immeasurable. Be joyful though you have considered all the facts. So long as women do not possess great power, please women more than men. Ask yourself: Will this satisfy a woman satisfied to bear a child? Will this disturb the sleep of a woman near to giving birth? Go with your love to the fields. Lie easy in the shade. Rest your head in her lap. Swear allegiance to what is nearest your thoughts. As soon as the generals and the politicians can predict the motions of your mind, lose it. Leave it as a sign to mark the false trail, the way you didn't go. Be like the fox who makes more tracks than necessary, some in the wrong direction. Practice resurrection.

—Wendell Berry

## Harlan and Anna Hubbard

One of the highlights of my stay in Kentucky last summer was a day as a guest at the home of Harlan Hubbard and his wife Anna. For the past seventeen years, the Hubbards have lived the kind of life so many Catalog readers (and writers) fantasize about: organic and self-sufficient, on a small farm by the banks of the Ohio River. The Hubbards' food comes from their garden, and their small goat herd, which provides them meat and milk. Their house is small, beautiful, and home-made, as is much of its furniture. They have no electricity, and although Mr. Hubbard is nearing seventy, he has no use for noisy power tools in his outdoor work. Both he and Mrs. Hubbard are strong, handsome, elegant, cheerful people. Mr. Hubbard is a painter and a writer. Mrs. Hubbard is a musician. Before they moved to their present home in the early 1950's, they lived some seven years on a shantyboat, cruising inland waterways. Mr. Hubbard wrote a book about that experience called *Shantyboat*. He has recently completed another book, as yet unpublished. I was so deep into the experience of my visit with the Hubbards I was reluctant to get into anything like a business conversation. But I did leave them some back copies of the Catalog, and later I wrote Mr. Hubbard inviting him to let the Catalog print an excerpt from his new book. His reply to that letter is printed below.

—GN

Dear Gurney,

We have been giving much attention to the Whole Earth catalogs and in time will have read every word in them. Have never come across anything like it. You are doing a great service to anyone who wants to form his life on a more natural, individual basis. For young people with such notions practical help is hard to come by, and they must appreciate the Whole Earth deeply.

Your letter and the catalog have aroused in me a new potential, perhaps a new responsibility. I would be most happy if something I had written about our experiences here would be a help and guidance to anyone wanting to live in a like manner; that is, to live close to the earth, in a natural way, providing the necessities by your own hands without becoming entangled in the system and all its ramifications.

Yet I do not see how a part of my manuscript could be printed separately. The whole thing is not long, and it is so closely integrated that no part would stand by itself. At least that is the way I see it. Perhaps you or Wendell could make some extractions. You would be welcome to do so, but I would prefer to wait until the book is published—if it is. I am not at all as hopeful as you are on that point.

I have ideas of writing something just for the Whole Earth catalog, but in truth I am not sure of my audience. Those of the "Whole Earth" type who have come to see us have for the most part gone away unimpressed. Appreciation has come mostly from people too old or too hidebound to make any change in their lives. I have thought this over since becoming acquainted with the Whole Earth catalog. What is the difference between young people today and myself as I was fifty years ago? Of course many differences are obvious. Yet I followed my own path without deviation, avoiding the pitfalls of college, jobs (that is, steady ones) and family. I worked only as much as I had to, and at manual labor. What led me away from the city and into the country was a positive attraction, not a negative denial. I wanted to enjoy the health, cleanliness, vigor, above all, the beauty of nature; to live a rude life, out in all weathers, close to the earth, my senses alive and keen; reveling in the smell of wood and newly turned earth, in the sound of bird song and running water, the taste of honest food when you are hungry. I was successful in realizing my desires as most men are, I suppose. I married Anna when I was 43. We lived for seven years on a drifting shantyboat, have lived here in Payne Hollow for eighteen a life of subsistence farming, in a patch of wilderness surrounded by the world of today, yet cut off from it; not involved politically or technologically. Outsiders make their way in, and they are welcome. All people are basically good and more important to us than any group.

How would all this be received by those who are in their twenties today? Not very warmly, according to my experience with them. Perhaps you would tell me why.

If I were to write anything for the Whole Earth catalog, it would be in this vein. Perhaps I have expressed it all here, except for some practical suggestions.

I have been writing this during a pelting shower in my workshop, too dark for much else. It is slacking now and I am running down. Evidently it is impossible to get anything else to you by Sept. 10, and I am sorry.

Your visit and your commendation meant much to us. We are not quits, by any means. In fact we have just begun.

—Harlan Hubbard  
Milton, Ky. Rt. #2 40045  
Aug. 19, 1970

## Friends on the Farm

The leeks came up pretty good, as did everything we planted, although I think the peas got planted too late—it was too hot for them to really do it. Our only disaster was spinach—it just came up and sort of wilted. In general the garden is spectacular and I can't think of a more rewarding way to break your back. I learned a lot from our neighbor, who is the best gardener in the valley, I guess. He doesn't mulch but he does cultivate a lot, so you could say he mulches with dirt. He grows a winter cover-crop, which I plan to do at the place we're hoping to buy... yes, we've found a canyon that's for sale—we just need to organize the money (I'd say we're about 25 grand short right now). A lot of our friends have had trouble with water, so that's one of the things we won't sell ourselves short of (what syntax!). This place we looked at has a spring that comes out of white rock, and two all year streams—and beavers and fish and elk and deer. Paradise.

Back to gardening... everybody around here is an organic gardener, although they don't talk or think about it. I asked our landlord if he sprays, when I went to plant the garden, and he said no, he wished he could, but his calves get sick when he does. We learned to plow, plant, brand, dehorn, and deball from our landlord—then our paths parted, since, as the summer wore on, he got more and more frantic (he has a lot of bills to pay off he claims) and we became less and less so. A lot of farmers in the valley work too hard, and are too greedy to really get it on with. For example we wanted to buy a piece of land from two people at the dairy—we knew they had bought it for ten thousand dollars seven years ago, so I figured (what naive!) that they couldn't ask for more than say 30—they asked NINETY!! Everybody got very pissed off and called them greedy cocksuckers and what have you—though not to their faces. But we did stop buying milk from them. We got over half gallon of milk from Alice (our goat) and Paula's goat Big Bag gives a gallon—we buy from her at fifty cents a gallon—a real bargain. Goats milk makes better yogurt than cows, I think, and it's so easy to make, Paula uses a lot of thermometers and pipettes, but me, I just heat up the milk till the bubbles form (that's called scalding) and stick it in the jar with a lid on. Then I let it cool till it feels like a hot baby (no shit... it should be just cool enough to not have a sting to it anymore), then I stick in the culture (three tablespoons of the previous batch—if you need a good good starter, buy some high class yogurt from the health food store—or Christian Hansen starter (Maybe Paula will provide the address)—then I wrap it in a towel and leave it sit (don't move it) till the next morning at which time it's done. That's for a quart. Goats are where it's at... Alice is as sweet as a dog... she responds to her name, doesn't need to be tied up—goats don't explode when they eat too much alfalfa the way cows do—and shits handy little pellets rather than huge mushy pies. Her only drawback is that she thinks she should live in the house, and is constantly trying to get in. We try to keep her outside the fence, as she was shitting a lot immediately in front of the kitchen door... whenever she gets the least bit excited, she pisses and shits.

We got a huge (30 cubic feet) freezer, and are trying to fill it up. Chip and Running Deer caught over a hundred trout one magic afternoon. They look great in the freezer, the trout, not Chip and R.D. And Toni's mother taught us that you can freeze greens by just sticking them in the freezer raw. So we have a lot of packages of chard and turnip greens for winter soups. I'm freezing herbs, too—raw. The discovery of all is that you can freeze corn straight off the stalk—in the husk. Just fold the open end down and secure it with a rubber band and throw it in. It only keeps about three months, but that should be long enough to eat a lot of the surplus corn. Our tomatoes look real good—they



are almost ripe, and there are about a dozen on each plant. However... the first frost is expected in just two weeks, which is a bit of a blow. Handy hint... (the reason for all those dot dot dots is that the colon is out on this type-writer) pick the green tomatoes and wrap them in newspaper individually, then store them in the root cellar. They'll keep for a real long time (six months, I hear, although nobody ever had enough green tomatoes to test this out), and you just bring em out a couple days before you want to eat them.

Before I forget: there is only one easy, clean, fast, convenient way of making sprouts. I got it out of a newsletter from organic gardening club in Santa Rosa. Soak the beans (if you want soy sprouts, mix them up with some mung beans—they'll sprout better) overnight in a quart mason jar. Only fill the jar about one fifth full of beans (one eighth if you're sprouting alfalfa). Cover the jar with cheese cloth or nylon window screen or some other real porous stuff—the point is to be able to pour water easily through the cover—as well as allow the air to circulate freely, which may be secured easily with a mason jar ring—or a rubber band, or a string. OK. After soaking the beans overnight, pour out the water—without taking off the handy screen—and rinse off the beans and drain em real good. Then lay the jar on it's side and cover it with a loaf pan or a towel. They should sprout in the dark. Put it in a warm place, and rinse off the beans a couple of times a day—this keeps them moist as well as clean. In fact this is the beauty of this sprouting method. Whenever I tried the other ways everything always rotted or just got plain nasty and slimy and you wouldn't want to eat any of it, let alone bring it into the house. But with the Santa Rosa Organic Gardening Club Method... no muss no fuss, and in two-three days you have a quart of real good sprouts. Then when you see the little leaves appear, stick the jar in the sun for fifteen minutes, and watch the leaves turn green (filling up on Vit. C.), and then into the refrigerator. A true cinch, I promise you.

We're pre-fabbing a twenty meter diameter dome in the cow barn. Right now we're putting together a model—ten feet in diameter. We're cutting the lumber at the correct angles (as many as six different angles per piece, I think—dome calculations are not my dept.) to avoid having to use hubs. Then we're stapling the struts together and sticking them together with hot glue. We think of adobe for the lower part of the dome, but probably will use gunnite if we can afford it, and vinyl pillows a la Jay Baldwin on top. It's gonna be two stories, and the downstairs many rooms. At first we'll all live there, then next spring (this is an idealized projection of events) we'll build individual family dwellings and use the big dome for eating, hanging out, and various workshops.

Elaine had her baby here at the house—the midwife had gone to Texas, so we got a local doctor to come over—he is over eighty, and an herbalist, but although his hand shook a lot, he knew his stuff and the birth was smooth as could be. We all attended, especially those of us who had been to other births. The difference between having a baby at a hospital (even a groovy one like Alta Bates) and having one at home is like the difference between pain and pleasure—the sensations are similar in the abstract only.

We've had scores of visitors all summer—we were over thirty people here last week-end—which sometimes is a strain. Happily almost everyone has been a dear friend, so the hassles involved in sleeping twice as many people (not to mention feeding) as you are prepared for has been minimized.

From a friend's letter



## the maine coast and cultural change

There is some kind of relationship between Maine's current environmental crisis — caused by the unplanned — for incursion of heavy industry — and the decline of agriculture-aquaculture in the state.

Maine used to grow things. A century ago the state was dotted with hundreds of productive farms. Most of them no longer exist; those that do are being phased out. The dairy industry, as Charles Sutton outlined in a recent Maine Times report, is becoming less and less profitable for the individual dairyman, and is becoming a corporate enterprise in order to survive.

Poultry farming is also becoming "big business" or none at all. The problems of the individual poultry man have been well defined by Maine Times in a series of reports during the past year.

Beef cattle, which could be raised in Maine on a much more significant scale, are generally missing from the Maine scene because nothing, or very little, is being done by state and federal leadership to help the beef producer solve his processing and packing problems.

Truck farming is almost non-existent, and the very few truck farms left are operated by men like Harry Prout because they would rather continue the struggle than change their way of life for obviously more profitable activity.

The vast potato farms of Aroostook are all that is left of the state's agricultural economy, and there is talk now that the market for Maine potatoes is shrinking each year.

Maine used to grow things, but now it grows only timber, and even that crop has become less and less substantial. Today's trees are grown for but one purpose: the production of pulp for making paper — a purpose which requires spindly trees, unfit for use as building material. (Maine's wooden homes are constructed with lumber shipped here from the west coast — a feature which Maine home builders are proud to point to.)

Grapes used to grow on Maine offshore islands. Coastal families used to grow their entire year's groceries in back yard gardens. Blueberries, apples, pumpkins, corn, carrots, raspberries, blackberries . . . they all used to grow on the thousands of Maine salt water farms that are now the summer homes of refugees from megalopolis, or the year-round homes of Maine folk who make their money all kinds of ways except from the land.

Even the Maine fisherman, the last holdout against technology, has begun to be changed. Corporations are applying corporate systemization to the lobster fishery. The offshore, deep-water fishery is on the verge of collapse, not only in Maine, but in the entire United States. Shell fishing has become the poor man's part-time occupation, and the Maine coast

dweller who uses the shellfish at his doorstep makes their use a special event rather than the routine gathering of a resource which is there to be husbanded instead of ignored.

The end of "growing things" has been well documented; our check list of mortality rates is a collection of the obvious illnesses and fatalities which have long been mourned by sentimentalists and historians of "the good old days". But not quite so obvious is the relationship of this basic cultural change to the future of Maine. Those of us, this journal included, who want to save Maine, repeatedly suggest a restoration of "growing things". We talk about aquaculture as a strong way of buttressing the coast with a productive industry that demands a clean environment, as opposed to an oil refinery, which runs a constant risk of producing a dirty one. Or we talk about making it economically enticing to put beef cattle on Maine coast ranges, thereby making it economically important to maintain clean, open grass land. Or we talk about planting and harvesting shellfish in Cumberland County the way potatoes are planted and harvested in Aroostook.

But the fact of history is that men of this time do not want to "grow things". The brutal truth of the history of the past century is that it has produced a human being who now opts 100 percent for the product technology which produces plastics, cars, color television, electric can openers, air conditioners, and so much food from corporate farms that farmers are being paid not to plant and surplus food stocks are mouldering in forgotten mills. This same technology is the one that demands so much energy that oil men's projections show the world's residual fuels burnt up in two more generations of ever accelerating need.

It is, indeed, this technology which has brought the oil men to Maine.

Can it be honest, or productive, then to discuss saving Maine with the very anti-technological lifestyles that agriculture and aquaculture require? In other words, is there any point to discussing and researching the building of an aquaculture industry along the Maine coast, when the people for whom that industry must be designed would rather watch a motorcycle race than plant a row of corn; or take a portable radio to the beach than dig in the tide flats for clams.

Perhaps those of us who see the salvation of the Maine coast in the restoration of "growing things" are allowing sentiment to interfere with logic, romanticism to obscure reality. Perhaps it might be much more profitable for Maine's environmental future to think about how to use the tools and truisms of technology to save the coast, than to attempt to restore it with a way of life that has apparently

# MAINE TIMES MAINE TIMES MAINE TIMES MAINE TIMES

Maine Times  
John N. Cole, Editor  
Peter W. Cox, Publisher  
13 Main St. Topsham, Maine  
Subscription rate: \$7 per year.

succumbed to a cultural change as basic as the invention of movable type.

These are not certain thoughts; they are merely questions raised. It is certain, however, that unless they are answered, the Maine coast may disappear because too many people came up with the wrong solution to a complex problem.

(JNC)

### Maine Times Lives!

Earth Times has folded. That's a loss, but maybe not such a great one at that, if more people start doing what John Cole is doing with Maine Times. He's not reporting on the whole earth. The state of Maine is his beat, and the results of his focus are obvious. Earth Times folded the same year Maine Times soared. Cole's weekly circulates all over the U.S., but his paper is primarily about Maine's ecological problems. Maine Times is revolutionary in that it's a straight business, dependent upon circulation and advertising revenue like most publications; and yet, it takes no shit. If the Times' editorial policy offends a potential advertiser, that's the advertiser's problem. Aside from its good work as a conservation news medium, the Times does a favor for us all by proving that power does not always rest in the hands of sons of bitches. The Times has been a central force in uniting Maine's lonely, isolated little voices for conservation into a tough political fist. It ain't hippies they're uniting, and Maine Times ain't a hippie newspaper, although the Freak spirit obviously dwells in the hearts of these newspaper pros. The Times lives at that difficult but special meeting place of overground and underground, with no apologies in either direction. So do a lot of other people, apparently. Maine Times circulation is climbing. Let's hope it's true, that as Maine goes, so goes the nation.

—GN

# Mining on Kirk's Creek

by Holly Musick

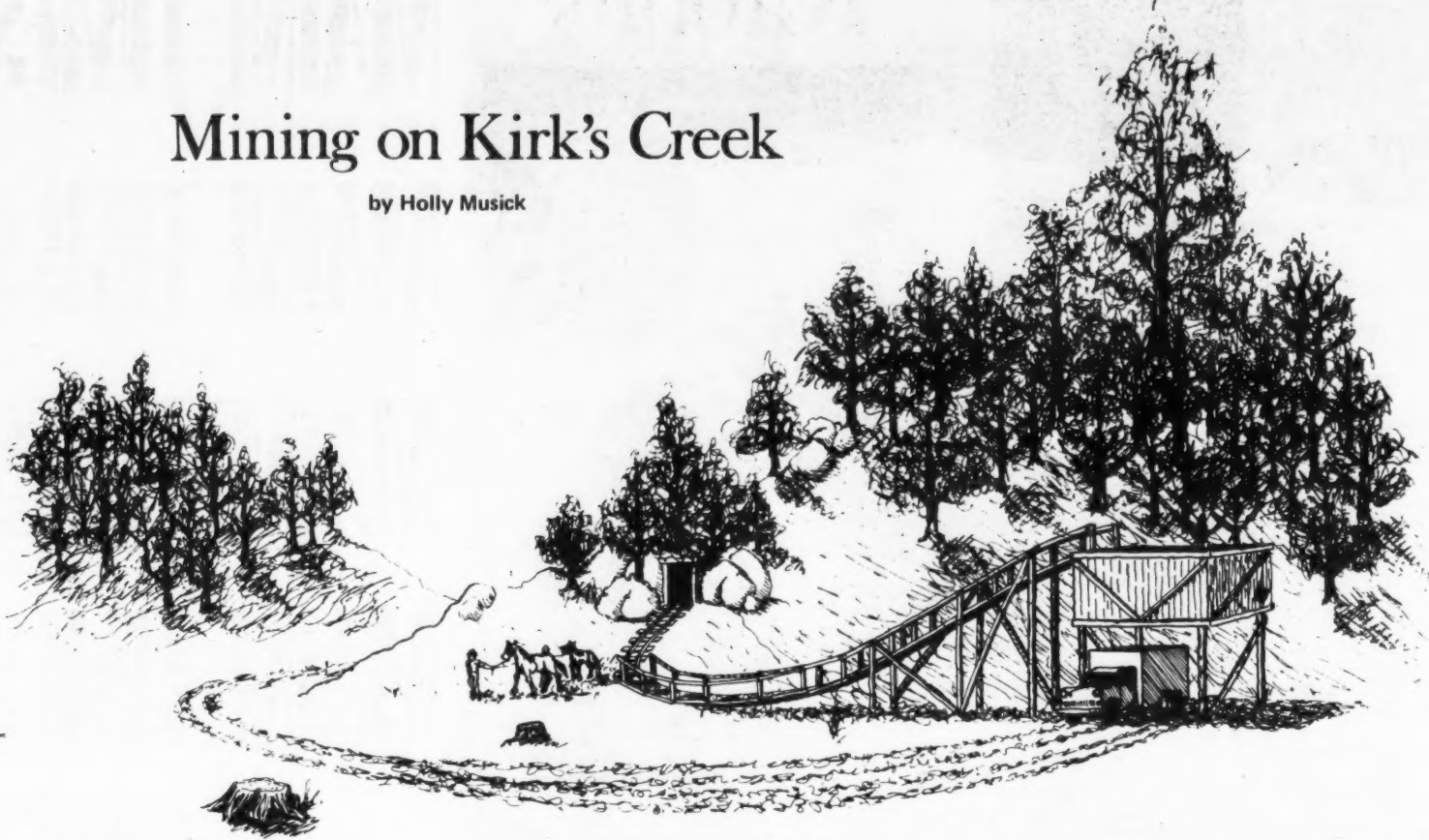

I was discharged from the army November 22, 1945 after serving 6 years. I was stationed in Fort Story, Va. in the peace-time army. Later I was assigned to the 738 Bt. Hq., at Camp Edwards, Mass. I stayed with the 738 until the end of the war. We were on Saipan when the war was over. The Air Force flew us to Hamilton Field, California, from where I was sent to Fort Bragg, N.C. and discharged.

When I arrived home my three brothers, all of whom had served in the army in World War Two, greeted me. They had just been discharged too, so we rested and played around for a month or two, before we decided to form a company and go into business. We thought over several propositions, and finally decided to open up a coal mine.

We found a big boundary of coal for lease for 15 cents a ton. This boundary of coal was located away out in the wilderness. We had to travel about 16 miles on the main highway, turn off onto a county dirt road and travel up Kirk's Creek for 5 miles. We leased this boundary of coal for 20 years.

We set out to open up the vein of coal. My brother owned a 1935 Oldsmobile car. We loaded our tools in the old car, picks, shovels, cross-cut saw, hammers and steelbars. There was no electricity on Kirk's Creek. The only thing we had was man power. The first thing we did was build a road down a small bank from the county dirt road to a small field on the property we had leased. We cut all the bushes and cleaned out all the old dead logs and trash. We built a bridge across a small creek. We picked up our saws and axes, walked up on the mountain and cut trees down for two days, big dead Chestnuts and Oaks. We rented an old horse and pulled all the logs down the mountain to the tipple sight and the drift-mouth of the coal mine. My brothers excavated a big hole in the earth, in a small field, about 7 feet deep, and hit the seam of coal. We drove a big steel bar through the seam of coal. We had a 52 inch seam of coal. This gave us the angle and the lay of the coal seam.

We picked up our shovels and picks and started to dig a big cut in to the mountain. We were soon under the loose rock. We set big timbers on each side of the opening, and placed heavy cross-collars from one timber to the opposite side of the cut. We were under the loose rock. We drove the tunnel about 4 feet and set timbers and cross collars, and then we drove big split timbers from one set of timbers to the next set. We drove the split timbers over to the cross collars and made a solid bridge which gave us protection. We set 5 sets of timbers and cross-collars, and by this time we had hit solid rock, blue slate, hard as a dry bone. We carried our breast auger to the tunnel. This piece of equipment was a 3-piece affair, a breast plate, a crank and

the auger. With a sharp bit on the end of the auger, we picked up the breast auger and started drilling a hole into the face of the rock tunnel. We drilled the holes about 3 feet deep and filled the holes full of dynamite. We lit the fuse and BANG! We rolled the loose rock out of the tunnel in an old wheel barrow, and blasted again.

The tunnel was 9 feet wide and 60 inches high. I worked in the tunnel with one of my brothers while the other two started to build the tipple outside.

The coal seam was 75 feet under the earth. At the mouth of the tunnel the coal seam was raised on an angle facing the mountain. We drove the tunnel a hundred feet and met the coal seam and faced up the coal. After we drove the tunnel 20 feet the rock was hard as flint rock. We had to sharpen our old auger often. Sometimes it would take as much as 2 hours to drill one hole. We were going about one foot a day in the tunnel. The air was bad, there was no ventilation. We decided to blast one day, and clean the loose rock out the following day.

We had to get some air in the tunnel, so we bought several joints of black 2 inch pipe and screwed them together and pushed them into the tunnel. We pulled the blower off the black smith shop and attached it to the pipe and placed the blower 3 feet from the ground. All you had to do was turn the crank on the blower and pump air into the tunnel.

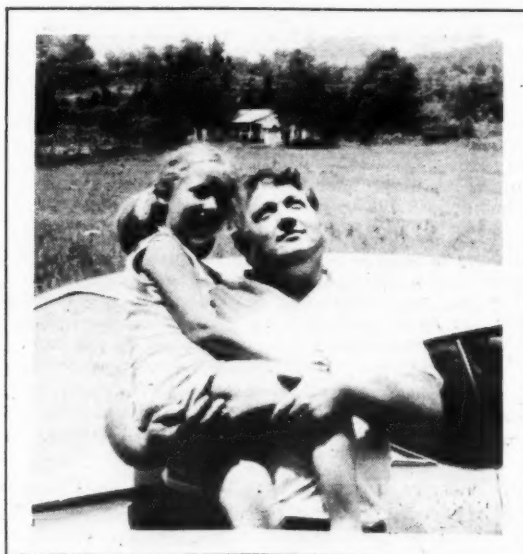

Holly and his niece Susan

When we were 60 feet deep into the tunnel the light was bad so we all bought a cloth-top mining cap. This cap had a leather attachment on the front of the cap, this was to hang your carbide lamp on. The carbide lamp was a 2-piece affair, the lamp screwed apart about the middle. The bottom compartment was for the carbide, the top compartment was for the water, water switch, face, and air vent so the carbide gas can escape through a tube from the bottom compartment. You just spit on the carbide, screw the lamp together and turn on the water switch, and stroke the flint, and you have a beautiful light.

We drove the tunnel one hundred feet and faced up the 52 inch seam of coal. We turned an entry in the coal to the left of the tunnel and drove the entry from one hundred yards, to a spot we were going to drive an air shaft to the outside. We laid two-by-four track down the tunnel and out the entry to the air shaft, and set an old mining car on the two-by-four track. We drilled a few holes into the rock and blasted. We were driving through the rock coming to the outside for an air shaft.

We measured the tunnel and the entries and figured all the angles. We come to the outside and measured, and figured all the angles again. My brother stuck a pick in the ground and said, "This is it, men, this is the top of the air shaft." The top of the airshaft was located about 50 feet above the drift mouth of the mine, and about 75 yards to the left of the drift mouth up on the mountain in a small cove. We dug a hole in the earth four feet deep and four feet in diameter. We attached a churn drill bit to a two-inch pipe 20 feet long and started to churn the drill up and down by hand. All four brothers were working on the churn drill at the same time. We pulled the churn drill up and slammed the drill in the hole, pouring water in as we worked. We drilled for two weeks. We had a hole 40 feet deep, by three inches. We stuffed the hole full of sixty percent dynamite and attached a fuse, and blasted. We walked back down from the mountain and pushed the old mining car into the tunnel out the entry to the airshaft. We started moving loose rock out the air shaft. We scooped the loose rock down out of the airshaft and loaded the rock into the car and hauled the rock out through the drift mouth. We cleaned all the rock out of the airshaft. I looked up through the air shaft and saw daylight. The shaft was 60 feet to the outside about 4 feet in diameter. It looked like a big smoke stack.

We walked out of the coal mine up the mountain to the top of the air shaft and placed a big steel barrel in the mouth of the shaft. The barrel had big slits in the bottom. We built a big fire in the barrel and the cool air swept through the tunnel up the entry and out the airshaft.

# Rabbits

About 40-million pounds of rabbit meat are consumed in the United States each year.



Flemish Giant

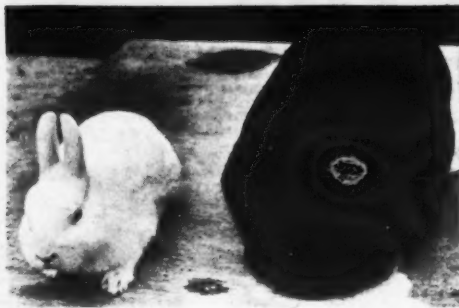

New Zealand Black (right)  
Ruby-Eyed White Polish (left)

## Rabbit Raising

The quotes on this page are from *Rabbit Raising*, a booklet published by the Boy Scouts of America as part of its Merit Badge Series. The booklet is cheap and packed with good information, charts, diagrams. RD and JL Hamilton say the whole series (astronomy, beef production, farm management, leatherwork, etc.) is good. See their say on Boy Scout manuals elsewhere, this issue.

If you have bought a young pair, you will have to keep them apart for a few months, until they are old enough to be mated. On the average, rabbits of the smaller breeds may be bred when 5 or 6 months old; medium-weight breeds should be 7 months old; and giant breeds, 9 months old. Does more than 4 years of age are too old to be mated.

The doe should always be taken to the buck's hutch. She probably will not allow any other rabbit in her own hutch, and will go so far as to fight the buck. Bucks, too, are timid about being in a strange hutch. (If you intend to raise more than one litter, one buck will be enough for up to 10 does. However, do not use the buck more than two or three times a week.)

After the buck is finished, he will fall over on his side.



Siamese Satin and Litter

You can test your doe from the 14th to 16th day after mating to see whether she is pregnant by "palpating"—that is, feeling for the developing young. Hold her ears and the fold of skin over her shoulders in your right hand; put your left hand under the body between the hindlegs and slightly in front of the pelvis. Move the hand gently forward and backward. The embryos will be easy to distinguish as they slip between the thumb and fingers. Caution must be used that neither doe nor young are injured.

Certain chores must be done on specified days after the mating date. For instance, on the 27th day the nest box should be placed in the hutch. Pack the box 3 inches high with clean straw, free of weeds and other foreign material. The doe will arrange the nest and line it with fur from her own body. If she fails to pull enough fur to cover her litter, you can do it for her. Pluck some gently from her side or hips—it will come out easily and make a soft bed.

Litters range from 6 to 18 young, depending upon the breed, age of the doe, and the season. The ideal number to leave for the mother to wean is seven. If you have two or more does kindling at the same time, litters can be balanced by taking youngsters from one mother and giving them to another on the first or second day after they are born. When the young are no more than 2 days old, neither doe will mind the transfer.

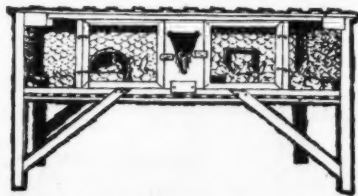

Plan to build and place your hutches so you don't have to handle the rabbits too much. Build them as simply as possible, so that they can be cleaned easily and kept clean, and will allow light and fresh air without admitting drafts and winds.

A rabbit is usually slaughtered by dislocating its neck or by hitting it on the back of the head with a stick. To dislocate its neck, hold the animal by the hind-legs with your left hand, placing the thumb of the right hand on the neck, just back of the ears, the four fingers extended under his chin. Push down on the neck with the right hand, stretching the animal, at the same time pressing down with your thumb, and raising its head with a quick movement.

Next, hang the dead rabbit on a hook, piercing the right hindleg between the tendon and bone just above the hock. Remove its head immediately and allow it to bleed, so that the meat will have a good color. Remove the tail, the free rear leg at the hock joint, and the front feet. Cut the skin just below the hock of the right leg and open it on the inside of the leg to the root of the tail, continuing the incision to the hock of the left leg. Carefully separate the edges of the skin from the body, but be sure to leave all fat on the carcass, and pull the skin down over the animal. A clean skin, free of fat, is easier to dry, and leaves the meat firm and attractive.

As soon as the skin is removed, it should be placed on a stretcher and hung up to dry. After the rabbit has been skinned, make a slit down the belly, starting at the tail. Remove the entrails, but leave the liver in place; then take out the gall bladder. Remove the right hind foot by cutting it off at the hock.

Care should be taken not to get hairs on the skinned rabbit; hairs are hard to remove and give the meat a dirty appearance. Rinsing the body in cold water cleans the carcass and makes it easier to remove hair and blood. Don't soak it for more than 15 minutes.

## Rambling Rabbit Rap

I spent most of this past summer with a farmer friend of mine who raises rabbits as a main source of table meat for his family. Six does and a buck kept in hutches at the edge of the garden provide regular meat for his family of four. Other than the heavy work of removing the manure as it accumulates, the rabbits are in the care of my friend's twelve-year old daughter, who feeds and waters them as part of her daily chores. Her father does the slaughtering as the young rabbits mature. The meat is kept in the freezer, and eaten at the rate of about one, sometimes two, a week.

I'd tasted wild rabbit before, but I didn't remember much about it, except that the occasion was loaded with an atmosphere of muted guilt, or at least an uncomfortable degree of self-consciousness. I was a kid at the time and I don't remember who the adults were, cooking and serving the meat. But I do remember the almost compulsive talk that went on among them about how wild rabbits were sometimes dangerous to eat, about how we probably ought not to be eating this one, but let's just take a bit of him anyway, and see. I took my bite, but what I tasted was the general misgivings about the whole thing. And those misgivings stayed in my head for 25 years, until this very summer when we were eating rabbit as a regular staple.

And it was great! It was at least as good as fried chicken, and maybe even a little better, depending on whose chicken you've been eating. My friend said that as far as the work of meat-production is concerned, rabbits are far less trouble to keep than chickens. He keeps chickens, but mainly for the eggs. (He raises beef and pork too, as well as a fantastic organic garden, all on twelve rather hilly acres. Working together, he and his wife and their two children come as close as anyone I know to total organic self-sufficiency).

We talked some about the question of animal slaughter, of killing other creatures to feed on them. He said that in the beginning he had some trouble killing his rabbits, but that he finally overcame it when he quit thinking of them as "bunnies" and looked upon them as simply a source of protein. That attitude will no doubt trouble the more committed vegetarians; but not many farmers putting in 10 and 12 hours work a day are vegetarians. If a rabbit is a fellow being, so is a corn stalk. Creatures eat creatures. Some day worms will eat us all, and whatever debt we may owe the carbon-nitrogen cycle will no doubt then be paid in full.

So went our dialogue. Or one chapter of it, anyway. One of the great things about the summer on the farm was the kind of running conversation we had, picking up hours and even days later where the talk left off before. Farmers certainly work a good deal more than they talk, but when they do talk, it's grand to listen in. The language of men working together in a field is a rare and special thing. Men who work together, summer after summer, for years, have a common body of lore, a mutual frame of reference that underlies everything they say. When its best is when the words begin from a concrete subject, rise into a grand abstraction, convolute a time or two then return to earth again. Our talk about rabbits was like that. We talked about them as "bunnies," against rabbits as food to eat. That got us into talk about the esoteric loveliness of a wagon wheel as a thing you paint and display in your front yard, against the loveliness of a wheel on an actual wagon that's helping you do the work necessary to your livelihood. Then we got into the difference between vocation and avocation, of the unhappiness that comes when a person's play is too far removed from his work. Raising rabbits is play, it's fun, a hobby. But it can also be work, good, productive work of the kind that contributes to health and vigor by getting good home-grown food on the table.

And so we got into the organic life as an ideal, a life in which opposites like "work" and "play" are reconciled. When your life is one of daily, personal "creation," of work that satisfies like play does, you're less in need of purchased, artificial re-creation. The average industrial worker does a job he hates in order to buy the things he loves, like food, and entertainment. His vocation is one thing, his avocation another, and never the twain shall meet. This split ultimately leads to the deadly division between city and country. And in the same way the modern vocation, or industrial job, is deadly to the individual worker's creative spirit, the city has become the deadly enemy of the countryside. To satisfy the appetites of the city, the countryside is pillaged by industrial, mechanized farms for food and strip mines for fuel for electric power. How neurotic, how divided our culture against itself!

And thus we came to the question, can the lowly rabbit possibly come to the rescue? We decided it could. Rabbits can be raised in any back yard, as food, primarily; but they can also be raised as a metaphor of a new and simultaneously old possibility, the possibility of cottage economy. They can be raised as a metaphor of opposites reconciled, of cultural schizophrenia overcome. They can stand as an image of country stuff happening in town, of town style stretched to embrace country substance, of work become play and play become work, which, after all, is not far from Adam and Eve's set-up in the Original Garden. I don't plan to hold my breath till the Golden Age arrives. But I do plan to raise some rabbits in my suburban backyard this year, and to eat the little morsels one by one when they are grown.

—GN

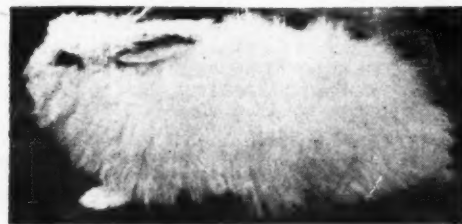

English Angora

## Books About Rabbit Raising

*Domestic Rabbit Production*, George S. Templeton

*I Choose Rabbits*, E.H. Stall

*Raising Rabbits*, Farmers' Bulletin No. 2131, Div. of Publications, Office of Information, Dept. of Agriculture, Wash. D.C. 20505 20505

## Magazines

*National Rabbit Raiser*, 241 W. Snelling Ave., Appleton, Minn. 56208

*Small Stock Magazine*, P.O. Box F., Pierce City, Mo. 65723

*The Rabbitman*, Auburn, Ala. 36830 36830

## Additional Booklets

*Commercial Rabbit Raising*, USDA Handbook No. 309, 70 pages, July 1966, Supt. of Documents, Wash. D.C. 20402, 30 cents.

*Rabbit Production*, USDA Bulletin No. 1730, 1950, 20 cents

*Common Diseases of Domestic Rabbits*, USDA Bulletin No. 45-3

# The Have-More Plan



## The Have-More Plan

The spring CATALOG listed Mother Earth News, a monthly magazine, as a new item. (p. 86). What we want to do here is call special attention to a particular issue of that magazine that by itself stands as a worthwhile tool for anyone about to get into cottage economy.

Mother Earth News #2 was devoted to the subject of homesteading, containing a complete reprint of the famous Have-More Plan, first published in 1944. Out of print now, the original publishers of the Have-More Plan say they intend to re-issue it some time in the future. But for those who don't want to wait, it's available right now in the pages of Mother Earth News #2.

The Mother Earth News  
P.O. Box 38  
Madison, Ohio 44057  
Back issue #2, \$1.35

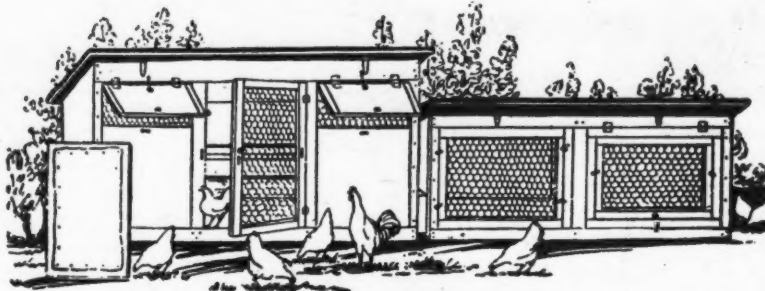
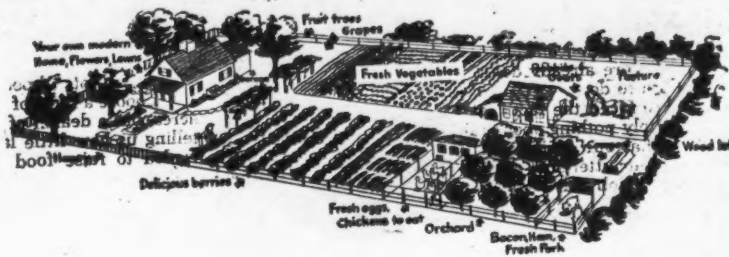

We bought this little poultry house and the scratch shed (at right) for our original backyard flock of 7 laying hens. It cost \$28.00. Since then we've used it as a coop to fatten broilers and as a shelter for our geese.

1	Why We Moved To The Country	10
2	A Letter To Wives	13
3	What Sort Of A Place In The Country Do You Want?	14
4	Setting Up A Homestead	15
5	Houses Especially Designed For Country Living	17
6	Plan A "Harvest Room" With Your Wife	18
7	Finding A Suitable Place	19
8	A Little House Can Grow	20
9	Score Card Of What To Look For In A "Have-More" Homestead	21
10	Water, Sanitation, Electricity, Roads	22
11	Landscape Your Place—Increase The Value 20%	24
12	Plans For A Small Barn	26
13	The Importance Of Raising Part Of Your Family's Food	28
14	A Good Garden With A Lot Less Work	29
15	Vegetable Planting Chart	32
16	Herbs	33
17	The Kind Of Berries And Grapes Money Can't Buy	34
18	Two Ways To Have Tree Fruits On A Small Place	36
19	Fresh Eggs From Your Own Hens	38
20	New Easy Way To Raise Tender Chicken	40
21	Geese Grow On Grass	42
22	Turkeys Can Be A Profitable Side Line	44
23	Ducks Are Easy To Raise	46
24	Squabs	48
25	Rabbit—8 To 14 Cents A Pound	50
26	Ham, Bacon, Pork, Lard	52
27	The Miniature Dairy	54
28	(a) The Modern Dairy Goat	55
29	(b) A Family Cow	58
30	A Few Sheep For The Small Place	60
31	Veal And Beef On The Homestead	61
32	Our Little Sugar Factory	62
33	Have More In Winter Too!	64
34	Winter Gardens—Cold Frames, Hot Beds, Small Greenhouses	68
35	Grow Your Own Fish	69
36	The Woodlot	70
37	Transportation And Power	71
38	Housekeeping On A Homestead	72
39	Homestead Mechanics	74
40	Earning A Living In The Country	77

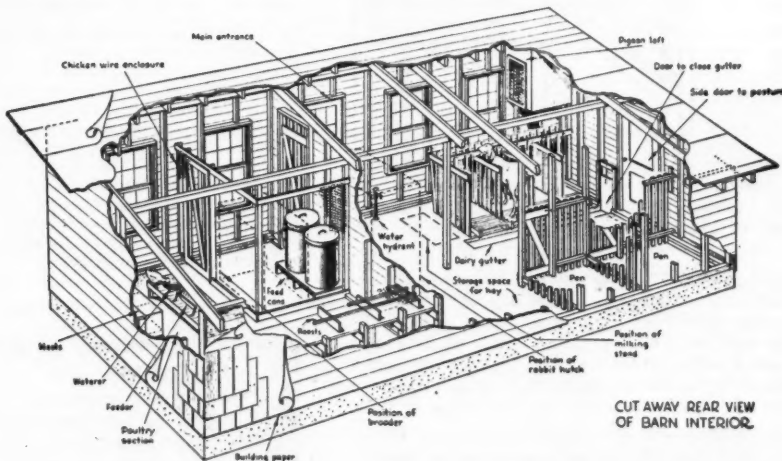

This "breakaway" drawing shows interior of our small barn. We found that this 16 x 30 foot barn efficiently houses 30 hens, 60 broilers, 20 or more rabbits, 4 goats or a cow and calf, 3 or 4 sheep, and a dozen squab. Barn cost \$200 to \$400. Bill of materials, plus complete building plans including 10 large detail drawings of front, ends, interior layout, goat stalls and milking stand, cow stalls, chicken section, squab loft, also a turkey sunporch are available.

## Raising A Steer

During the meat shortage there was a great revival of interest among small farmers, estate owners, and homesteaders in beef for home use.

If your place has enough good pasture (1 acre per steer) and enough good quality hay (2 acres of clover or alfalfa would be ideal), then you might consider raising a steer. Shelter can be simply a three sided shed; if you don't have to carry water, then a steer won't take much time.

## Salt Some Away

Another easy way to keep certain vegetables is to salt them down. The one big fault with this method is that it destroys a lot of the vitamins and minerals. For this reason we have not done any brining (except to make sauerkraut, ham and salt pork).

Everybody knows about salting cabbage to make sauerkraut. I put mine up in jars as I have found this even easier than the crock method. It is also possible to salt away corn, beans, cauliflower, turnips and peppers.

Alternate layers of washed vegetables and salt are packed into earthen crocks and weighted down. If enough brine to cover vegetables completely is not formed, a concentrated brine made with boiling water may be added. Use 3 1/4 cups of salt (common or coarse salt is better than fine table salt) to 6 quarts of water. Keep in a cool place—the vegetables are ready to use at any time.

To desalt for use, put salted vegetables in a big pan, cover with cold water, heat to luke warm, stir and pour off water. Repeat until vegetables are only slightly salty. Then you can cook in regular manner.



The little girl is four years old—but the dwarf fruit tree has been planted only two years. And just look at the apples!

## Dwarf Fruit Trees

Now, after many years of experimental work really good dwarf fruit trees are available. The two exciting things about dwarf fruit trees is that they take very little space and they bear fruit a year or two after you plant them whereas with standard trees you have to wait four to eight years!

Take a look at the comparison chart on the next page. It will help you decide which type of trees to plant.

Hensley Settlement is one of the last self-sufficient mountain communities in America. Its last resident moved out in 1951 leaving behind a way of life reminiscent of 100 or more years ago.

Situated on Cumberland and Brush Mountains approximately 10 miles northeast of Middlesboro, Hensley Settlement consists of 28 log buildings on a 508-acre plateau. Although it is believed that people lived in the area as far back as the Civil War, it was not fully settled until inhabited by the Hensley family.

The land first came into Hensley ownership in 1903 when Burton Hensley purchased it from R.M. Bales. Hensley gave an interest to each of his 16 children after selling 100 acres to a son, Jack, five acres to another son, Al, and 38.2 acres to Sherman Hensley, his son-in-law.

Sherman was the first to acquire legal title to the land and in 1904 became the first settler of Hensley Flats, as it originally was known. He and his wife, Nicey Ann, reared 19 children who married and started their own families in the mountaintop village. Eventually, only Hensleys and Hensleys-in-law — such as the Gibbons family — lived in the settlement which attained a peak population of about 160 in the 1930s.

Because of its remote location, Hensley Settlement had little contact with the outside world. But the Hensley clan preferred it that way, visiting Middlesboro or Pineville only to vote, pickup mail and, occasionally, to do some shopping or trading.

Outside of spices, coffee and tea, the mountaineers purchased little in the way of foodstuffs. Their food was adequately supplied by farming with corn, potatoes and beans being the primary crops. Virtually every farm also had orchards plus hogs, chickens, sheep and some cattle. Wild game such as rabbit, turkey, squirrel and deer also was available.

The village also had a cane mill, two water mills and a blacksmith shop that produced hand-forged farming and household tools. A 40-inch coal seam supplied coal to the settlement.

The settlement depended upon moonshine whisky as its greatest source of income. Nearly every man operated a still, running off up to 25 gallons at a time. The whisky was taken by horseback into town and sold for \$10 per gallon.

Because of its isolation, the settlement had little interference from outsiders, where whisky-making was concerned. Court records do show that several members of the clan were fined for moonshining, but law officers generally left the settlement alone.

One story is told about a Bell County sheriff who did make the trek up the mountain, but was so overwhelmed by the Hensley hospitality and good whisky that he forgot all about making any arrests.

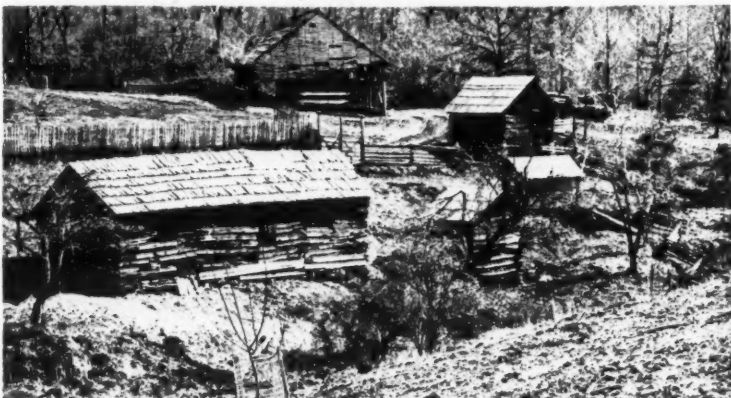

**WILLIE GIBBONS FARM** — Willie Gibbons, an in-law of the Hensleys, lived on this farm that is currently under restoration. Gibbons' 22' x 45' cabin is at left followed by (from left) a smoke house, chicken house, granary and a barn (background). The barn measures 29' x 40' and has individual stalls for the animals and a full-sized loft.



A one-room school house was one of the 28 buildings that originally comprised the settlement. The school was started about 1912 and was part of the Bell County school system. Eight grades were taught, but most of the children stopped after the fourth grade.

Teachers boarded in the settlement and went down the mountain only about once a month. Many of the teachers stayed in the settlement and married into the Hensley family.

There was room in the log building for about 20-22 pupils, according to Mrs. Wallace Hensley, a former teacher there. The peak enrollment was about 17 school records show. During the 1941-42 school year 15 were enrolled — 11 Hensleys and four Gibbons.

The original schoolhouse burned down, but was rebuilt in the early 1940s. After World War II attendance dropped off and the school was discontinued in 1946.

Each farm in the settlement had about five buildings . . . a cabin, barn, smoke house, hog house, chicken house and outdoor toilet facilities. The cabins had up to four rooms and were made entirely by hand. Each cabin had its own fireplace with most having two, the second being in the kitchen, which, often times, could be entered only from the outside.

The mud-chinked cabins had log walls that were six to eight inches thick. The puncheon floor boards were up to 36 inches wide and three inches thick.

## Hensley Settlement



**"EASY, CHARLEY!"** — Charles Grace examines the loft of another style barn while Jim Coomes takes a safer look from ground level. Each Hensley Settlement family used its own style of architecture. This building originally had a double wall for insulation purposes.



**HINGED BY HAND** — Lloyd Abelson, the Park's chief historian, examines a handmade hinge in one of the buildings. The hinge is a block of wood with a hole in the center through which a shaft, that was attached to the door, passed.

Social life in the settlement consisted of quilting bees and house raisings. Church services were not held with regularity because of the isolation. One Sunday; however, usually was designed as "dedication day" for all church functions. At this time, all marriages, baptisms and funeral services were held for those events that had taken place earlier.

When residents became ill, they were attended by some of the women who practiced mid-wifery or taken down the mountain to Middlesboro. The fact that life was hard in the settlement is reflected in the cemetery where 35 are buried. A number of the graves contain the bodies of children who only lived a few days. Bonnie Gibbons, the infant daughter of Mr. and Mrs. Bert Gibbons, is such an example. Her gravestone notes her birth as Aug. 19, 1941 with her death occurring two days later.

Around 1942, many of the men in the settlement left to enter military service or defense work. Following World War II, they were reluctant to return to the Spartan life of Hensley Settlement. The population steadily dwindled until only Sherman Hensley remained.

Sherman, now in his 80s, lived there alone for approximately two years. He sold the land to the Kentucky State Park Commission in the late 1940s and moved to Caylor, Va., in 1951.

The land was purchased from the state in 1955 for the establishment of Cumberland Gap National Historical Park.

Reprinted from Kentucky Utilities Company Employees' News

# Appalachia

If you're interested in Appalachia—and there are lots of reasons to be interested—here's some good books about the place. These books don't exhaust the bibliography, but they're a good place to begin. From pre-settlement to modern times, the important chapters in the Appalachian story are represented in these books. And each book will lead you into ten others, if you want to go that far. Why go that far? Why is this particular mountain region of special interest? It's a mysterious place, for one thing. Some geologists say the Appalachians are the oldest mountains in the world, that possibly they were once connected to the African continent, before vast geologic upheavals divided them with oceans. The Appalachians were the wall of mountains that pinned American settlement to the coastal regions for more than a century. The breakthrough that occurred in the 1770's represented the first giant step of what became the transcontinental westward movement. The Appalachians were "the west" at one time, the first frontier; and ironically, in many ways they are becoming frontier again in the 1970's. Although the westward movement passed through there nearly two hundred years ago, it is in Appalachia that we find one of America's strongest, most viable folk cultures. Folk culture has survived in Appalachia because large parts of it remained cut off from the progress the rest of the country enjoyed the first half of this century. There was a railroad across the plains and deserts to California by 1869; the railroad didn't get to Hazard till 1912. The last twenty years have seen major changes in Appalachia, of course; you have to look hard for the folk culture now; there are new highways through the hills you have to get off of to find it. And looking for it you may get distracted by stock-car racing, or a stretch of strip-mined hillside. Appalachia's worth studying, too, as a model of the awfulness that can happen to a place when the effective power over the land rests in the hands of absentee owners like coal and steel companies, or when most of the capacity for initiative is sat upon by an ass as fat as the federal bureaucracy. Appalachia was the first region to get undone in a wholesale way by automation. The worst consequences of thoughtless automation are in those hills, in the form of unemployed coal miners, and, again, of strip mining. But the main reason, and I think the best reason, to know about Appalachia, is happier than what I've said so far. As a place that's been wiped out, the slate is clean there; at least the terms are very clear: aint no way to go but up. And there are some upward energies stirring, some new stuff trying to happen, an abundance of possibility, if not of probability. What there is mainly is a lot of blasted land, a kind of garbage heap of wasted land, that exists today as open space; it's muddy space, but still it's space; kind of the left-overs of a century of violent industrial practice. I haven't seen any domes on strip-mined hillsides yet, but I can imagine them. I can imagine one sitting very neatly on the little place where my great-grandfather had a farm once upon a time; where a major deep mine operated for 50 years; where strip-miners drove their bulldozers when the deep-mining was through; and where today there's nothing but a wierd vine creeping like a fungus over the exposed sub-soil of his old farm, and thousands of surrounding acres. I can imagine that. And a good deal more. Oh man, can I imagine a good deal more.

—GN



**Stinking Creek**  
John Fetterman  
1967; 192pp.

**\$5.95** postpaid

from:  
E.P. Dutton & Co. Inc.  
201 Park Avenue South  
New York, N.Y. 10003

*This is the story of a Kentucky mountain community, and one of the very best books to come out of modern Appalachia. Written by a professional newspaperman with soul, Stinking Creek is one of the most honest books I've ever read. He avoids "evaluating hillbillies," avoids playing the role of the expert. He respected the good people of Stinking Creek enough to simply listen to them, and let them tell their own story.*

Hear Frank Patterson, a retired miner:

"I used to work in the mines. Lord, that was dangerous. My God, they got killed every day. Sometimes five and six a day. But people wasn't gettin' no other work. A man'd get killed; another'd take his place."

"Those lamps on your caps burned lard oil. They had a little ol' wick, and the smoke stayed in your face all the time. We didn't have no fans to clear the air out. Oncet we dug a channel straight up for fifty feet to the top of the ground. Then we put a furnace under the hole to burn coal in. It would make a draft and draw air through the drift mouth. If the air got heavy, you'd have to go to where the air was. Times, the air got so dead you couldn't get your breath. Oncet the air was gone, and the lamps was jest sparkin' 'stead of burning, I said, 'Let's get out,' and I run to the trapdoor. I was so weak I couldn't open it. I lay down with my face against that door tryin' to get me some air. I got to feelin' better with that air, but I heered my buddy strugglin' back in the coal vein. He was just about gone when I got to him, but I got him out of there."

And Henry Brown, age 81:

"My legs have give way and my eyes water so bad I can't see," Henry complains. But he can identify a mule several hundred yards down the road from his porch. "From my knees to my neck I'm sound as a dollar. Feel like I'm sixteen in all that part of my body. But my head stays stopped up. I had a notion to go to Lexington and see one of them head specials. These doctors here know very little more than I do. One wanted to experiment on one of my girls. I said, 'You experiment on one of your own girls, you want to experiment.'"

"There's a heap of good healing stuff right here on this mountain. There ain't a weed on this globe but what's a benefit if you know where to put it." He pointed a veined finger toward the slope behind his house. "Right thar's a ragweed. You could be running off at your bowels. Nothing but water. You bile down those ragweed tops and make a tea. Drink half a cup. It'll stop. Blackberry roots do the same thing. A bowel complaint on anybody is well right off."

"Hit's a weed around here—we call it niggerweed or sometimes iron blood. Dig the roots. It makes your iron blood. If you ain't got enough iron blood and get run down, you may have enough of the other blood but no iron blood. Brother, this niggerweed will put it in you. And swamp root. It's good fer different things. Bile it down into a strong tea, and there stands the prettiest blue oil on top of that water you ever saw. It's good for your kidneys. Bile it down good and strong."

"I tell you what I always wanted to eat—a big bowl full of clear grease and some biscuits. That was my main eatin'. But now I can't eat no breakfast. Now, the biggest thing I live on is milk. I got a good cow. She's a four-year-old blocky cow. I wouldn't sell her fer no kind of money."

**Night Comes To The Cumberlands**  
Harry M. Caudill  
1963; 394pp.

**\$6.75** postpaid

from:  
Little, Brown and Company  
34 Beacon Street  
Boston, Massachusetts 02108  
(also available in paperback)

*This is the definitive biography of modern Appalachia, particularly the coal mining regions of West Virginia and Eastern Kentucky. Caudill is a descendant of people who came to the mountains before 1800. A lawyer and former member of the Kentucky state legislature, he is the most eloquent and persistent voice of outrage against strip mining, and the coal industry in general which has raped the Appalachian hills. Particularly interesting are the descriptions of life in the coal towns of Kentucky from the 1920's on.*

So immense was the coalfield and so roadless and rugged its terrain that the process of buying up the region's wealth necessarily consumed considerable time. Commencing about 1875 with the first roving timber buyers and their wildcat surveys, the task was not substantially complete until about 1910. By that year a major portion of the land was owned in fee simple by nonresidents. Perhaps three fourths of the remaining salable timber was held by absentee investors and at least 85 per cent of the minerals had passed out of the hands of the plateau dwellers. Thus the stage was set for the most momentous single occurrence in the history of the Cumberlands—the building of the railroads. After years of rumor and speculation, the iron horse was to intrude upon the ancient solitudes of this beautiful land.

The mountaineer's imagination was fired by this event as by nothing else that has befallen him in his long sojourn in the Southern highlands. He hoped that the much-touted railroads would bring many benefits. The income from the sale of his timber and coal, small though it was, had caused him to acquire a taste for things he could not make and which money alone could provide. His quickened appetite for "factory goods" remained, but his money was soon gone. Hence the boom promised by industrial development offered hope for more such desirable things. Perhaps he and his sons could find jobs at high wages at sawmills or in mines. More and better schools might be built so his children could "larn somethin'"; the tempo of life would quicken and his drab existence would take on new color and sparkle. The mountaineer had come to look forward to the new era for many reasons, but most ardently because he knew that his long isolation would be broken and the monotony of his ancient mode of living would be interrupted by new experiences. He was confident of his ability to profit from this new and startling event. Though he had known many hardships and his folk memories groped back through eras of toil, tears and blood, he had never known failure. His life, like those of his ancestors from the Piedmont and the Blue Ridge, had been lived in fiercely free independence, and when the gangs of track layers first poked into the long valleys of the Kentucky, the Big Sandy and the Cumberland, they found the essential physical environment of the plateau remarkably unaltered. Though millions of logs had been sent down the river and many coves were not growing corn instead of tulip poplars, the changes wrought by such labors were not large and thousands of acres of still virgin timber persisted on every hand. But these outward appearances were deceptive. Now the trees that shaded him were no longer his property, and he was little more than a trespasser upon the soil beneath his feet.

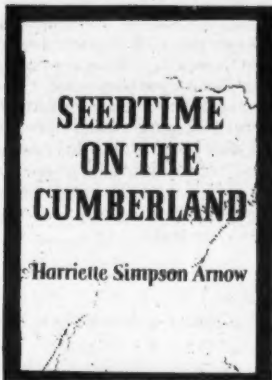

**Seedtime On The Cumberland**  
Harriette Simpson Arnow  
1960; 449pp.

**\$7.95** postpaid

from:  
The Macmillan Company  
866 Third Avenue  
New York, New York 10022

*Miss Arnow combines her talents of novelist and historian in Seedtime to produce a beautifully-written account of life among the settlers on the Appalachian frontier. Her geographical focus is the Cumberland River drainage, which begins in Eastern Kentucky and sweeps south-westward into middle Tennessee. The book is loaded with details of frontier life-style which provide pictures not only of the pioneers' daily life, but their psychology as well.*

Von Graffenried had chosen his people carefully, so that most needed skills would be represented, as many were required. There had to be carpenters, joiners, plasterers, and sawyers in order to build the only kind of home they knew to build on the rockless, clayless coastal plain—one of sawed timber. This, in addition to skilled workmen, demanded saws, hammers, nails, trowels, chisels, shingles, and lime that had to be got from the burning of oyster shells.<sup>44</sup> Such a house took time in the building that might have gone to clearing fields and fortifying against the Indians; and during the long weeks of its building the owner and his family had to live in some makeshift shelter such as a tent or even house of bark and boughs, thereby increasing their liability to illness through exposure to rain and cold.

The man who could with felling ax, broadax, drawing knife, auger, and froe ride into the woods and in a few days' time build an all-weather house of logs in which he could live decently, and in comfort when it was finished, was not there. The "house made of logs such as the Swedes very often make in America,"<sup>45</sup> was still very much a rarity on the Carolina coast.

The New Bern settlers had brought plenty of clothing, but soon they were almost naked. They had when food got low, bartered clothes with a nearby tribe of Indians for "wild meat, leather, bacon, beans, and corn." Less than a day's journey away were game-filled woods, but there were no hunters in New Bern, and nobody to teach hunting.<sup>46</sup> There were in North Carolina at that time famous hunters, who could, wearing the head and skin of a deer, stalk the living animal until they could get close enough for the kill; but these were Indians.<sup>47</sup> The white hunter, so proficient he could make money from the selling of skins, was not yet in America; the North Carolina planters paid the Indians to hunt for them.

Skills alone were not enough; it is true any man who would survive on the border had to be an artist in the use of the broadax, skinning knife, scraper, hoe, froe, auger, awl, adz, and other tools, but equally important or more so was a knowledge of the woods. All borderers who lived as farmers were woodsmen. The forest was only part enemy to be pushed aside for cleared fields. It was for the Virginia or North Carolina settler a vast and seemingly bottomless widow's barrel yielding up all manner of things from walink for the newborn baby's tea to dogwood for the weaver's shuttle. The settler had to know these offerings, where to hunt a slender hickory sapling for the corn pounder sweep, lightwood for a bit of tar, cane stalk for the weaver's sleigh, a small and crooked white oak for a sled runner, but a straight one for a splitting maul. He had to know his wood-poplar for heaving and gouging, but cedar for riving, and so for several dozen: what would sink and what would float, what would bend, and what was best for a shoe peg. He was dependent upon the woods around him not only for building materials for house, barn, fence, much of his furniture, and many of his appliances from pitchfork to gunstock, but the woods gave him fuel, drugs, dyes, and a good bit of food. All new-settled farmers, even the wealthy, had, until fence could be built, to use the open range so that meat, milk, and butter came from woods pasture.

Years ago before the days of consolidated schools and good roads, I taught in remote sections of Pulaski County, Kentucky now part of the Cumberland National Forest. My pupils were chiefly the children of small farmers, but all around them were the woods. At that date in that community most farm animals were still on the open range so these children like earlier generations spent much time in the woods; in rounding up the forever straying animals, in going to church, school, or to a neighbor's, and in collecting herbs, fruits, nuts, fuel, and in hunting and trapping.

They had had no nature study or lessons in woodcraft, but on a Monday morning they could, with no apparent study of the either muddy or dusty road, tell all who had ridden or walked by the schoolhouse during the weekend, for they knew every shoe print, mule and horse "sign" in the neighborhood. They knew the common names as well as uses of several dozens of plants,<sup>17</sup> and they knew them winter as well as summer. One faint clink of a distant bell and they could tell whether made by horse, cow, or sheep, who owned the animal and what it was doing, grazing or sleeping or "hid-out." They could track a strayed mule or hog or cow for miles when there were no tracks I could see.

They, no different from the young hunters of earlier generations, ranged over rough lands and were never lost or hurt. They delighted in swinging out over creek or river and dropping into a pool of water; they climbed tall trees, explored sinkholes, caves, creek pools, rockhouses, yet I never had a school child hurt by a fall or suffer a snake bite, and though many of the boys started hunting alone at ten years of age I can recall no gun accident. Bred into them was the same caution the hunter had to have; a perch in the swaying top of a "slim" fifty-foot hickory made for good safe fun in a high wind, but only a fool would on a hot summer day stick his hand under a rocky ledge or into any hole where he could not see—that was a good place for a copperhead to be. They were forever cautious; they respected the woods, the caves, and the river as one respects honorable enemies; young children were constantly watched and guarded against the dangers there, and it was not until they were eight years old or so they were allowed to walk the paths alone.



**Cabins In The Laurel**  
Muriel Earley Sheppard  
1965; 313 pp.

**\$5.95** postpaid

from:  
The University of North Carolina Press  
Box 510  
Chapel Hill, N.C. 27514

*Cabins in the Laurel is a record of Mountain life in Western North Carolina during and before the 1930's. The area has changed in this past 40 years; only small pockets of the old simple life remain but what there is is worth knowing about. At first you might take it for Americana or funk, but you soon see that the people are really far out. There is a ballad in there sung by a woman named Frankie Silvers. The song is her answer to her executioner's question: "Do you have any last words?" There is a portrayal of an ecstatic scene inside a Holiness church wherein a woman becomes a saint by dancing and wailing until the congregation joins her. These are true stories.*

[Reviewed by Dave Smith]

## On Heroes

*Daniel Boone had a land fantasy. He wanted to cut loose from the straight life of the settlements and go live someplace that made a greater demand on his talents and creative energies. He didn't like the economics of the settlements. Too much usury, too easy to get in debt, too hard to get out. His style and temperament were thwarted by people dealing only in the safe and known. The people in the settlements, the good burghers, were so bent on insulating themselves from the dangers of the unknown, they wound up insulating themselves from the pleasurable possibilities as well. In an essay the poet William Carlos Williams describes Boone as "a great voluptuary born to the American settlements against the niggardliness of the damning puritanical tradition." Boone was a sensualist, desperate to engage the raw, natural world directly. As a man of his own time, Boone performed the classic act of the truly modern person: he embraced the new world of possibility that lay before him, and didn't look back.*

*People who are truly of their own time are the result of a process, children of an evolutionary working that cannot much be hastened by artificial means. It took 150 years to produce Boone and the Long Hunters, men capable of looking at the wilderness face to face without flinching, without glancing back to the settlements, and to Europe, for assurance. They were the products of what Harriette Simpson Arnow, in her book Seedtime On The Cumberland, calls "the long learning." The long learning was a period of several generations in which descendants of the original coastal settlers gradually learned to get along away from the sea, farther and still farther inland. Gradually the grandchildren and the great-grandchildren of an ocean-oriented people came to acquire the skills and attitudes a mountain man had to have. It was a slow and reluctant process, but by degrees individuals were formed whose growing expertise in the woods matched the waning of their interest in the old world of their fathers.*

*There were many factors that accounted for this early "generation gap," but the crucial one was the willingness of the woodsmen to learn from the Indians. People before Boone's time went on expeditions in the woods, of course. But always with Indians as their guides. They hired Indians to hunt and track; it was nearly a hundred years before it began to occur to the coast-dwellers that they might learn the Indian skills themselves.*

*Williams says of Boone, "To Boone the Indian was his greatest master. Not for himself surely to be an Indian, though they eagerly sought to adopt him into their tribes, but the reverse: to be himself in a new world, Indianlike. If the land were to be possessed it must be as the Indian possessed it."*

*And so the metaphor is inescapable: today's middle-class consumer culture as a Mother Country to cut loose from; then a period of long-learning, in which modern frontiersmen gain the individual competence that allows them to do the necessary, practical things. Indians were the original teachers. They are with us still, their ways and attitudes remain as models, to emulate and learn from. But today they are joined by others who qualify as "Indians" of a sort, by virtue of their skills which allow them to function as teachers, as shamans, as knowers of The Way. Certain thinkers, certain mystics, certain far-out entrepreneurs, qualify, but so do certain small farmers and artisans, aborigines of a kind, native to their places, there on the land to be learned from by modern Long Hunters willing to range beyond the settled places in search of education and adventure.*

*The Long Hunter is the hero of his time, in any age. He is himself in a new world, Indianlike; sensuous in his relationship with the natural world around; one who has left the Mother Country intent upon being of as well as in whatever wilderness he encounters. I'm sure that's an oversimplification, but at least it's a handle on the definition. And definitions are important. As the new world unfolds around us, so a new mythology comes into being, peopled with new heroes, and new styles of heroic behavior. In trying to arrive at a new heroic definition, it's helpful to read up on heroes who have gone before. Seedtime On The Cumberland is filled with tales of heroes. The thing you begin to realize as you read about them is that in most cases they were in actuality complex, mortal people like you and I who simply rose to the occasion that was before them, and did what they were called upon to do.*

—GN

# LETTERS FROM PRISON

Dear \_\_\_\_\_,

I may be making a mistake in writing to you but the potential of a positive constructive outcome seems to warrant the gamble.

How difficult it is to write a comprehensible letter to someone you've never met. Your efforts and contributions toward ecological harmony and environmental adaption, as evidenced by your 'Whole Earth' catalog, makes me hopeful that you are a socially aware person in these times of increasing chaos and planet wide violence. You seem to be looking ahead to the practical aspects of future survival. This is the person to whom I write— one whom I could really dig if I were free to do so.

I have lived in the wilderness, both alone and with 'The People' communally, seeking a life positive approach to self and social realization away from the negative pressures of our consumer oriented socio-economic insanity. Your 'catalog' would have been a boon to me then as it no doubt is to my many brothers still pursuing a less cluttered life away from the cities.

I must tell you now that I am being held a prisoner for having cultivated a small crop of marijuana. It is relative to my present situation that I think a correspondence between us might lead to constructive possibilities which you can utilize in your project and ultimately benefit the people.

Briefly my idea is this. Much undirected life energy is idly dissipated within prison. There are many creative and clever people held here who have no constructive outlet for their energies. Were they to have the thought provoking benefit of your catalog at hand and know that their better ideas might reach the people, much of this energy might be directed in a life positive direction, benefiting all.

If we can develop a correspondence, the few necessary obstacles can be easily overcome. I can order the catalog with prison approval and introduce it to fellow prisoners. Communication between us as friends will enable the outflow of ideas to you.

If you are interested and wish to communicate with me further it will be necessary that you be placed on my mailing list. If you respond in the affirmative to the party thru whom this letter is conveyed, I will be so advised and will initiate an application to place you on my mailing list as a friend. You will then receive a form to fill out requiring certain information that must correspond with what I place on my application. In your response to this letter you must tell me your age, home address and full name. I will state that we have been friends for nine years. That is all we need.

Although we must write as old friends, I hope you will still be able to convey a subtle introduction so that I may better know the person who seems to me now a worthy one whose goals are harmonious with mine. Whether you respond or not, I sincerely wish you well.

• • •

Briefly I'll acquaint you with an outline of the intervening years since we last met. I was still practicing civil engineering then as well as my hobbies of pharmacognosy and gardening as relating thereto. Subsequently I dabbled in diverse forms of relating to life, trying some prospecting on the Rio Yaqui in Mexico, collection of lady bugs in the Sierras and range seeds in several western States. All of which was quite joyous and close to earth. I spent several months living by foraging and hunting in the Sierras—getting things together both within and without. Spent a few months with the Univ. of Colorado in Boulder in their Organic chemistry laboratory as an employee—then split for Mexico and spent an incredibly joyful year digging Huatla de Jimenez, Oaxaca and so on. Returned and soon found myself being treated as a dangerous criminal.

• • •

Joy—that is what your letter brought me this otherwise meaningless Monday—the first letter in three weeks from someone alive outside. Lack of stimulation from self directed people is one of the greater negatives of this existence in prison. One must constantly fight a regression into vegetative functioning in such a void. Letters like yours jolt me back to heightened awareness.

• • •

Again your letter catalyzed an already high level of energy awareness. I have been fasting since Saturday and the clarity is crystalline.

While this intensely high energy level persists I may deluge you with daily letters until I discharge what has been too long pent up having no real outlet. Perhaps you may glean an occasional pearl from the bursting verbosity if you can bear the torrent. I am all too aware of the dangers of symbolization, the many pitfalls of the semantic morass but yet this is the only bridge we have for interchange of our energies—and though an inferior pathway—they are better than none at all. I'd far rather sit facing you on that hilltop in soundless but richer exchange and communion—and one day that may be For now—words!!

• • •

Black marks on white so linear and structured yet the love that needs sharing behind them. 'but what to do'

To the extent we interact and depend upon the projects of a system which is ecologically self-destructive, joy inhibiting and authoritarian structured, we thereby contribute energy and support to the demise not only of ourselves but to all planet life energy. Since any life exploitive social structure vitally depends upon the continuing cooperation through energy contribution of all its participants—the very basis for such imperatives as the training of docile conformism and life repression—indoctrinating dependency, inducing self inadequacy, encouraging the code of the follower, etc. ad nauseum, in a socially self perpetuating life negative spiral so tightly and habitually reinforced in every possible way so as to exclude all possibility of alternatives. The spiral is susceptible and vulnerable only when awareness is elevated and mistaken assumptions dissolved—when distorted value systems can be seen for the emotional quagmire they really are. Only then, with mind unfettered clarity, can effective change be wrought. So far as we can cast light and contribute to such clarity we contribute to a future—without it there may well be none.

Lack of knowledge, addictive attachment to the glitter of the pleasure baubles dangled by the system's salesmen are but two of the reasons for incomplete re-directing of energy. Ego trips of revenge—violent oppositional energy discharges are others. Too few look beyond the first hill and many yield to the lure of creature comforts as the uphill path steepens. The seeing through must embrace all levels—all attachments—all illusory values that have so effectively been imprinted to insure continuity of rigid institutions designed to convey the illusion of security through stasis in a creation of ongoing change which alone is certain.

However, the path widens—ages, stars and cycles laugh at the illusions of permanence—pyramids pass, cities crumble—change will not be denied.

To the extent we enter the stream and are guided by its currents—no longer clutching debris for false comfort—but yielding to the unstoppable flow joyously, then, brother, we do well whatever we do.

• • •

I have been lending some energy to low cost fabricated in place lake or lagoon surface dwellings—knowing of several locations where such would provide rent free, tax free dwellings, food available, for the fishing, amidst harmonious surroundings. How buoyant do you suppose volcanic pumice aggregate surface sealed to prevent water logging in a concrete slab with incorporated empty bottles for added buoyancy where strength not needed, would be?? I have found some boulders that have so much entrained air that they float as is. Cast in place with perhaps empty drums for added buoyance. So far, lake space is generally unrestricted in many areas. I know of several lagoons where this would be especially groovy.

• • •

I have been waiting for an inspirational state to set down what I have learned of cardboard. It has not come so I will struggle to convey what I can as best I can. I wish I could show you directly rather than risk confusion on a word trip—but here goes

First I'll describe a couple of basic slab designs— #1 for seats, etc where concentrated body loading occurs and #2 for side framing, backs, legs, table tops, shelves, etc where more uniform and less concentrated pressure develop. Both slabs use triangular ribbing as primary stress members like a truss somewhat. For speed and ease of construction these are formed from one large sheet of cardboard and folded along straight lines (over a table, for example). For slab #1 the folds should be 4" apart and for #2 they are 3" apart. The folds alternate one way way then the other to yield a piece of cardboard that looks like this:



Apexes of triangles must all lie in one horizontal plane.

Next, stiffeners are cut from another sheet all with a 3" base (triangles). They can be cut more quickly by drawing a repeating pattern and cutting several with each cut. Laid out like this:



on as large a sheet as desired.

For slab #1 they will have a 3" base with sides 4" long—For slab #2 they are equilateral 3" on a side. They will have to be trimmed shorter so that when in place they will have bases flush with apexes of the ribs. Cut one to size and use it to lay out the remainder all the same. The stiffeners are then glued into place between the ribs with all contact edges getting a coat of glue. Best glue is the polyurethane powder mixed with water as it gives a very hard set and is water proof. Later a coat of the same glue over all finished surfaces will relatively water-proof the finished item. Spacing of the stiffeners should be 2" center to center under focused loading areas such as under the pelvic bone contact for chairs seats and at 3" centers elsewhere. They should be staggered from one rib to the next in an alternate pattern as thus:

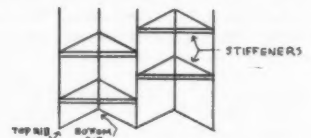

When all stiffeners are glued in place you have a solid unit. All that remains is to glue on the top and bottom plates. A liberal coat of glue is brushed on one side of each plate and pressed onto the ribbing with assorted weights until dry.



The slabs thus formed can be saw cut to any desired shape and end strips glued on to finish the appearance. They can be constructed to any size—ribs added adjacent and plates overlapping to develop very large panels for interior wall framing—room dividers, etc. For furniture they can be utilized in ways limited only by imagination.

To utilize the gradual contouring effect, wait a few weeks on chairs before final finishing until this develops—then finish. A liberal outer glue coat will both partially waterproof and fire-proof. The surface can then be hand painted, lacquered, sprayed or covered with fabric—whatever.

• • •

One small but measurable beneficial aspect of imprisonment is the objective viewpoint attainable with non-involvement except in involuntary parasitic fashion with the whole traditional social morass. It is so difficult while flailing in the quicksand to turn a cool eye at it all.

• • •

The limits of exploratory reach are described by what we think we know. To the extent thought configures an end to our journey, there is an end to exploration—expansion halts, we become as dead. There is no goal—only a way, in which all share.

• • •

I've been trying to say free all prisoners in some fancy, alternative way, these letters do it for me. they're from a friend. i've left things out, to protect the innocent. I think he'll understand.

NOTE

We finished building the tippie. We used the big dead chestnut trees for the structure, and lined the inside of the tippie with two-by-eights. We used big spike nails to tie the tippie together.

The tippie set out in a little field. It was 40 feet higher than the drift mouth of the coal mine. To overcome gravity we built a trestle from the coal tippie back to ground level of the mountain, and laid steel track down the trestle. Then we graded a tram road down the mountain to the drift mouth of the mine. We laid steel track down the incline to the drift mouth of the coal mine.

We walked back up the mountain to the top of the grade, installed a hoist, powered by a 1927 Chevrolet engine. The drive shaft was attached to the hoist. We hooked a steelcable to the mining car, put the old Chevrolet engine in low gear, and give her the gas. The mining car climbed the incline. When the mining car reached the top, we shut off the gas of the engine. The car switched automatically and headed for the tippie. We had a brake on the drum, just hold the brake with your foot and let the car run easy. The mining car had a big hook on the front gate. This hook contacted a chain stretched out across the tippie. The mining car had a swing gate in the front of the car. At the end of the trestle on the tippie head there was a set of tippie horns. This was a one-piece affair, about nine feet long with horns on the end, 42 inches apart, like a billy goat's. The car drifted down the trestle and hit the tippie horns setting on the tippie head and dumped the coal out onto the tippie screens. The screens separated the block coal from the egg. Then we dropped the gear shift into second gear and pulled the car back off the trestle and dropped the car down the incline to the drift mouth, empty and ready to be taken back inside and filled again.

Once we got the shaft dug and the tippie built, we were ready to run coal. We bought an old truck, 9 new mining cars and seven ponies to power the mining cars. The ponies were small enough to walk into the mine and pull out a car full of coal. We used the ponies in string teams, like the Eskimoes use the dogs. Our ponies were smart as dogs. Most of the time we used two ponies to the team, a lead pony and a wheel pony. The lead pony was the quarterback. He was lean, calm and smart. The wheel pony was built stocky, wild, strong, and a little crazy. The mining car was on his heels at all times. Sometimes we used three ponies in string teams. This was the swing pony in the middle. He was usually the lazy pony.

The first thing a pony driver did in the morning was harness the pony teams and blindfold the lead pony's right eye. This was a soft cloth covering the pony's eye. The pony driver hooked his pony to the mining car and travelled into the mine. At the first switch in the mine he stopped and removed the blind from the pony's eye. When they started to return to the outside he would reinstate the blindfold.

We were driving out of Kirk's Creek one evening. We saw a gang of men installing power lines up Kirk's Creek. The REA soon reached our coal mine. This changed many things. We had electricity. We installed electric fans in the airshaft, electric drills, booster fans, electric hoists and pumps. We ordered new trucks, built another tippie and dug a new opening in the seam of coal. We leased a spur track from the railroad and built loading docks to load our coal in the gondolas. We sold coal to trucks and shipped coal by rail. We successfully ran our coal business from 1945 until 1953, when the coal business went down all over the mountains.

Holly Musick

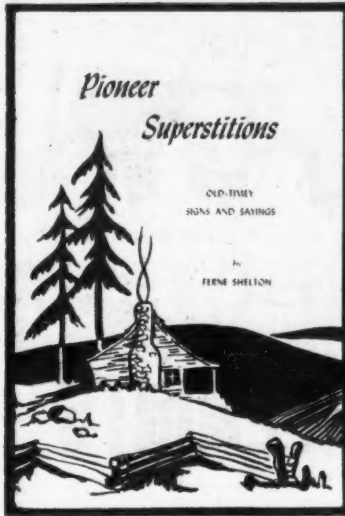
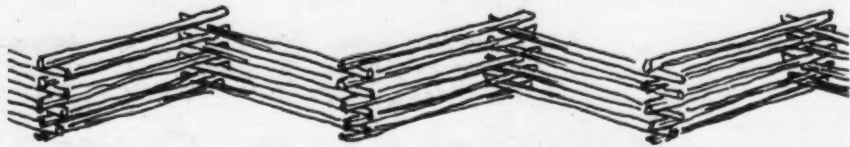

Pioneer Superstitions  
HUTCRAFT  
High Point, N.C. 27262



#### IDEAS ABOUT HEALTH

To stop "night sweats" — set a pan of water under the bed.  
(Improvement begins after the third night.)

To relieve cramps in legs and/or cure bunions — turn the sufferer's shoes upside down and place under the bed.

To make childbirth easier — 1. Raspberry leaf tea was taken during pregnancy. 2. An axe or knife was laid under the bed.

To heal cuts faster — put medicine on the knife, too.

Unlucky to sleep often in the moonlight. (Insanity results.)

#### PREDICTING WEATHER BY SPECIAL DAYS

Rain on MONDAY means several rainy days that week.

If the sun sets clear on TUESDAY, expect rain before Friday.

Rain on the FIRST DAY OF THE MONTH, most of month will be wet.

Rain on the first SUNDAY of a month means rain on the three following Sundays.

If dandelions bloom in April, expect a hot, wet July.

If March is dry, expect plenty of rain later in season.

If no rain on JULY 2nd, no hard rain for 6 weeks afterward.

If cold before NOVEMBER 15th, expect a mild winter to follow.

If the sun sets behind clouds on Thursday, rains before Saturday.

If the frogs "holler" early in a warm MARCH, they will "freeze back" three times before Spring really comes.

If the last FRIDAY AND SATURDAY of a month have good weather, the month to come will be nice. (If bad, expect a bad month.)

If there is bad weather on EASTER SUNDAY, the 7 Sundays following will also bring rain.

Every day over 100 degrees in JULY means one below zero during the month of January to come.

#### FAITH AND POWER HEALERS

Many people were believed to possess a supernatural "gift" for curing certain ailments, by using charms, prayers and magic of various sorts. (Mothers kiss a child's hurt to "make it well.")

TAKING FIRE OUT OF BURNS — One says she blows on the burn and mutters "Go out fire, come in frost." (Various other ways.)

STOPPING BLOOD — One "who has the power" says he calls the person by name, walks toward the sunrise and repeats the Sixth Verse, Sixteenth Chapter of Ezekiel (or reads it from the Bible.)

REMOVING WARTS — (Many different ways.) The conjurer rubs the wart with a penny and gives it to the boy. As soon as the penny is spent, the wart goes away.

CURING A BABY'S "THRASH" — A person who never saw his father (due to death or otherwise) may blow into the baby's mouth three times and cure the condition.

#### LUCKY CHARMS

(Worn as "pocket pieces" or as a necklace. Supposed to protect the wearer against ill health, bad luck, and other disasters.)

For RHEUMATISM . . .

Hickory nut; Horse Chestnut; Buckeye; Potato; Copper wire around arm or leg; Wide leather belt.

For NOSE BLEED . . . Red glass beads; a whole nutmeg.

For "FITS" . . . Peony seeds (tied in a bag around neck); Tooth.

For LUNGS . . . Old penny (around neck); Asafoetida.

For CROUP . . . A whole nutmeg; Black silk tie around neck.

For COLDS . . . Wool string around neck; Red onion tied to bed.

For STOMACH CRAMPS . . . Red string tied around the abdomen.

. . . A "MAD STONE" was used to remove infection. (Indian)

#### UNCLE JOHN SAYS: "Watch out for a man" . . .

. . . If his ears grow too close to the top of his head.

. . . If his beard is a different color from his hair.

. . . If he jingles money in his pocket while trading.

. . . If he does not make friends with a dog.

. . . If he looks hard into his cup before he drinks. (Thief)

. . . If he has very small ears, or his fingers lay close. (Stingy)

#### IT IS A SIGN OF RAIN . . .

If cream in coffee collects at the top edges of a cup.

If dogs suddenly begin to eat grass.

If cats sneeze or lick their fur backwards.

If field mice run wildly in the open areas.

If a pig straightens the "curl" in his tail.

If cattle refuse to drink water in dry weather.

If sheep turn their backs to the wind. (Heavy rain.)

If hens spread and ruffle their tail feathers.

If a rooster crows at night. (Rain before morning.)

If chickens go to roost earlier than usual.

If robins sing loud near the house.

## Beware Of HyLab

I am a cameraman working for a film company on location in Colorado, and am a California resident. I am writing in regard to a very unfortunate incident which has recently happened to me.

In your March 1970 Supplement you listed the HyLab Company, Box 8625 Chicago, Ill., and described them as selling chemicals to small laboratories. Because my son has a chemistry set and I often have need for chemicals in my profession, I wrote them at the end of May requesting a catalog and/or price list. I received a letter from them in the middle of July in which they explained they were sorry but they were out of business and could not help me. Last week a friend of mine that is a deputy sheriff in this town informed me that the town marshal had received a letter from "a chemical company" informing him that I was ordering chemicals to make LSD and that I should be placed under observation.

This allegation is absolutely untrue and I consider it a flagrant violation of my civil rights and an invasion of privacy. In the light of recent activities of the FBI in libraries, the action of the special police unit in Santa Barbara, the Kent State incident, just to name a few, I am very concerned. I don't know if this company is an FBI or police front but I don't like it. I am very upset that you would list a company like this in your catalog without a more complete investigation of it. I wonder how many of your readers (without better contact with their local police than I have) have innocently written this company and are now on police lists or are under surveillance as potential subversives. I would hope that you could print some kind of warning to your readers to avoid this company.

We appreciate and enjoy your catalogs but now we must wonder if we write for anything that might be considered illicit such as books on drugs or pot, political books, chemicals, etc. that we may end up on the same or other police lists for observation.

If you should decide to investigate I hope we hear from you.

I am also writing Senator Alan Cranston, HyLab company, and my lawyer.

Larry G. Logan  
Telluride, Colorado

## Sudbury

You should definitely know that soil test kits were tested and the SUDBURY KIT flunked! Shocking isn't it.

This is from a soil textbook *Soils, An Introduction to Soils & Plant Growth* by Roy L. Donahue. He quotes Ernest L. Spencer & J.R. Beckinbach, "The Value of Soil Testing Kits in Vegetable Crop Production" from the Florida Agricultural Experimental Station Circular S-48. They end up recommending the Hellige-Jruog kit (from Hellige, Inc. 3718 Northern Blvd. Long Island City, 1, N.Y.) It is no doubt more expensive—but really, are you going to test your soil or not? It is also remotely possible that Sudbury has fixed their kit since the test.

Mikal Deese  
Rockport, Wa.

I thought I would drop a line of criticism on an Item I am critical of, the Sudbury Soil test Kit. I ordered their 40\$ kit mistakenly thinking that the ad "more tests" meant more different kinds, actually it is more of the same as the small kits. Also in the Southwest their potash test is invalid. High Alclinity makes the Potash an unavaliable to the testing. When testing high ph (above 7) soils even though they are derived from granite and highly mineralized mountain soil, they test as defficient in potash, this is not the actual situation as potash is available to the plants through by products of organic decomposition, if enough organic matter is used.

After working this out I wrote a letter to Sudbury asking to return the kit, the Invoice stated that kits on free trial cannot be returned without permission from the company (there was nothing like this in the add) there was No Answer for a long while then a HEAVY Letter demanding payment and no permission to return the kit which I had decided was NOT the most useful garden aid I have ever used. I just packed the thing up and returned it to them and that was that. So I recomend that anyone who wants to try this kit buy the smallest and intend to keep it unless they want to hassle.

Jim Sanford  
Gila, New Mexico

## Craftsman vs. Woodcraft

Re Craftsman Wood Service (listed in the catalog). I ordered 4 items from Craftsman July 2 and enclosed a check in full payment.

After a 50-day hassle I ended up with a partial refund, one item for which they had substituted a different size. Neither of the two items I received was of better or more unusual quality than I could have obtained locally.

I suggest you remove Craftsman from your catalog because of POOR QUALITY, POOR SERVICE, UNUSUAL DELAY, and FAILURE TO SUPPLY 3 of 4 items ordered.

In comparison: I sent for and received 2 separate orders from Woodcraft Supply Corporation during the above period of time. The quality was excellent to superior and the service was superior; I received my order in less than 2 weeks. I highly recommend Woodcraft to anyone who would like the best at average cost with rapid service.

cc: Craftsman

Karen J. Jacobs  
Pompono Beach, Florida



## COMPLAINTS

### Trapped Us

You are providing the incentive and/or the means for talking up a wide number of alternative occupations. About those on the general theme of 'back to the land':

Does not the 'Animals Beware' ad, on page 19 of the July supplement advocate, condone by it's inclusion the use of extreme cruelty? Surely there is nothing alternative about the use of this back to the land item, it is merely extending the reach of city bred nastiness into the wilderness. I realize that these cruel jaw animal traps have been used for many years—but surely you are about encouraging NEW woes of virgin territory? In a previous catalog you picture a wolf and a cub and made a plea for the preservation of the species. The two items do not exactly match up. You do not plug organic farming on one page and arsenic weed killer on another, so why be inconsistent about this?

I hope that the editorial staff might consider scrubbing the plug in future editions, a few moments of thought on a fox or a badger chewing off it's own foot in order to escape such a trap would possibly provide some incentive. Best of all—why not an actual disclaimer? Surely it would not be against any stated intentions of your publication to clearly point out that traps which cause acute pain to animals are in no way endorsed by you? "Catch 'em alive AND unhurt" traps are available for those wishing to catch breeding stock or animals for the table which can be killed instantly within the trap. I expect most manufacturers carry such a line. Two I know of are:

Havahart Humane Animal Traps  
Allcock Mfg. Co.  
North Water St.  
Ossining, New York 10562  
(specializing in humane traps)

The Johnson Company  
Waverly, Kentucky 42462

Hopefully...  
Rod Chadwick  
Portland, Oregon

### More On Aladdin

A note on Aladdin Kerosene lamps—You ought to say that you'll get a column of flame up the chimney if you do forget to baby the flame too long—also—more importantly, I'm told you risk a dandy fire if you knock one over lit, and see no reason from the design, that shouldn't be true. There's nothing (or was never when I was using them) to keep liquid kerosene from running into the chimney if they're horizontal. (In a Coleman, of course, the feed is pressure, so constant unless you turn the valve—Aladdin's had wicks).

Thad Curtz  
Santa Cruz, Ca.

### Sense And Patience

*People, you gotta use some sense when you read the catalog. We don't know everything, & we ain't always right. And you gotta use some sense when you complain. Like the P.O. is fucked up & out there it often takes 3-4 week to get Parcel Post from back East, longer 4th class book rate.*

*Write to the company first and give them a chance to rectify the problem. If they don't, write to us & send us copies of your correspondence. We just might cease to list the company. Let us know about unusually good service, too.*

*Be gentle. Sometimes we carry very small companies. They often have a very hard time coping with the volume of enquiries they receive as a result of their unrequested listing. Especially when most of the requests for literature seem to be just curiosity. That kind of thing can break a small company. So don't write just to keep your mail box full.*

Fred

## Hughes Is Swamped

This letter is to let you know that the Hughes Company of 8665 W. 13th Avenue, Denver, Colorado, 80215, that is listed in your catalog is not an honest organization. I placed my order in January for a dulcimer kit. Since then I have written two letters asking where it was and finally a third asking for a refund of my \$14.45 or the arrival of the kit. Needless to say I did not even get the courtesy of a reply.

May I request that you warn your readers against this dishonest or nonexistant organization.

In reference to the letter regarding the Hughes Company which I sent on July 28, 1970, I wish to report that I finally received my dulcimer kit by means of a friend who was passing through Denver. My friend received courteous personal attention from Mrs. Huges. She explained that because of the ad in your catalog, they were so deluged with orders that they have had difficulty keeping up with the demand and in keeping orders straight.

Thank you.

Jodi Watts  
Alexandria, Va.

## BBC

I disagree most strongly with some of the sweeping statements made in Hugh Nolan's letter on page 41 of your July supplement re. the B.B.C. in England and radio in Europe generally.

I am English and I miss like blazes the intelligent, broad minded, enter entertaining variety of the BBC's radio and television broadcasts. I am told that some expensive radio sets obtainable here, do actually pick up the BBC. Incidentally if anyone has any knowledge of these—like which model is the cheapest that will pick up BBC programmes—it would be a worthwhile item for W.E.C.

BBC radio puts out four separate channels, different in staffing, content, editorial policy etc etc. Broadly speaking one is pop and fairly underground—it is frequently causing controversy and is not stagnant, a second is 'light', the 'Mantovoni for the mums and dads' section but with plays, magazine programmes, live comedy and variety shows. For some reason a sort of tradition of blue comedy shows persists at the unlikely spot of early Sunday afternoon. The third is up and away highbrow, no other way to describe it. It has a minority audience but it's expenditure sheets do not show it. They do wierd things like a live recital of a one handed drum concerto which runs for two hours. I made that up, but on April 1st they have been known to do things just like that, to see how many appreciative letters they can get from pseudo intellectuals. The fourth channel is for news, documentaries, plays, talk shows—(though I hesitate to use the term because I don't mean a Merv Griffin of the radio type of thing) — education. They have a university of the air starting up, which will enroll students and give degrees and run in conjunction with Oxford, Cambridge, etc—and for years people have been doing unlikely things like learning Chinese and Russian from Saturday mornings with their radio. I do not mean to say that BBC programmes are without fault, but they are the best in the world. Any professional from any other nation will readily agree with that. I do hate to see them knocked, and I especially hate to see the BBC put down in the U.S.A. in case this affords solace to any member of the American radio/T.V. audience and makes them thus less concerned about the quality of their own media.

MOST IMPORTANTLY—I have to completely knock down Nolan's clear allegation that the BBC "is totally government controlled and run." This is fuel to an already existing fire of misunderstanding which is too prevalent outside of England. The FACT of the matter is that the BBC runs under a unique system of control named a Royal Charter. They have a board of governors and a chairman and they virtually control themselves. Any attempt by a mere politician to impose his will on the corporation is proclaimed by the watchdog press and a general public outcry. Harold Wilson had a well known difference of opinion with the BBC and for many months would only appear on the rival commercial TV networks. He wanted a less aggressive, pre-agreed format, interview agreement. The BBC said "no chance" and so he simply stayed off the air and kept as many of his sidekicks off the air as he could persuade also. All that occurred while Mr. Wilson was Prime Minister and is well documented. Does that sound like government CONTROL? That is only one incident, there are constant news reports of attempted government interference in broadcasting which all get absolutely nowhere. Usually these attempts are extremely mild overtures which certainly would not raise an eyebrow here, but they rate screaming protest publicity nevertheless.

R.M. Chadwick  
Portland, Oregon

## Alaska Sleeping Bag Co.

I sent an order into the Alaska Sleeping Bag company for \$14.00. They not only did not send me what I ordered, they did not send me back my money, so I suggest that perhaps you should not give them any future plugs in your catalogs.

Ellen Louise Humes  
Cheney, Wa.

The item we ordered was the dog pack.

## We All Agree

The Hitchhikers handbook is almost useless, not at all worth a \$1.95. I am condensing its worthwhile information here for anybody who is considering buying the book so they won't need to.

1. Take as little as possible
2. Camp out
3. Carry a pack
4. Look pretty straight
5. Smile

Most of the book is stuff you learn after a few days of hitching, or else stuff you don't need to know. The best way to learn how to hitchhike is to hitchhike and that's true for a lot of other stuff too.

Your friend,  
Peter Wilson

Hey—

The useful information in the *Hitchhiker's Handbook* (\$1.95!) could be put on an 8 1/2 x 11 piece of paper & xeroxed for a nickle—sign, smile, back-pack, check out the driver, travel light, & it's okay to hitchhike. I'm disappointed in the *Catalog*.

Peace.  
Bob Woodbury  
Davis, Ca.

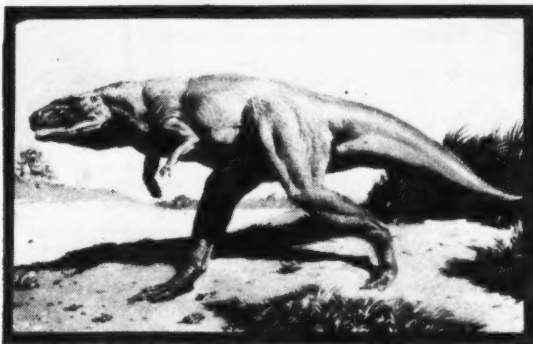

Sirs:

I am pictured on the reverse side out in search of my March *Whole Earth* supplement that has not yet arrived.

Love,  
David Batchelder  
Northampton, Mass.

## Japanese Saws

I noticed one of your correspondents was looking for Japanese Saws PP50, March cat. Tell him to try Japan Artisans 15 West Ferry St., New Hope, Pa. 18938 Mrs. Cooper & Mrs. Allison are great people, & will do mail order on Unbreakable items. They are the only source I've found for saws, also for Japanese papers, etc.etc.etc. ONLY place for Tea chest paper!!!!

In Peace & hope  
Chris Wolff  
Berkeley Heights, New Jersey

PS Soaking an Ax handle in water is fine for a temporary job, but when the wood dries it will shrink more, & flying Ax heads result. (A BUMMER)

## Hatches

You listed our library on your community page under nutrition, and lots of people wrote over for booklists which we don't have as we are also a food store and at the moment have not enough hands and too many customers. But there will probably be a list by fall, so certainly keep us in. The loan period is two weeks, books being kept by people past that time cost 3 cents a book a day.

Namaste  
David Handel  
Mildred Hatch Library  
8 Pine St.  
Saint Johnsbury, Vt. 05819

## Molasses Man Found

Robert Morse, the Molasses Man, is at 15-20 202nd Street, Bayside, New York, 11360.

Thank you for a superb July WEC. It has helped the rainy season float by.

OM  
Betsy Klein  
Assistant Editor  
OMEN PRESS, Tucson, Arizona



## Found: Harold Bate

On P.47 of the July *Catalog*, (*Out-Put Your Income*) we ran an article describing the work of Harold Bate, a British inventor who has developed a way to power an automobile with chicken shit—via methane gas. We've had lots of inquiries, & finally got a proper address for Mr. Bate. He wrote us a super-nice letter, & seems to have descriptive material of his project to send out. Write to:

Harold Bate  
Pennyrowden  
Blackawton  
Totens—Devon, England

## Northwest Looms—Well Worth It

I would like to report on/review the looms made by Northwest looms to counter the impression given by Karl D. Smiley in the March '70 Supplement (p. 7). We ordered an 8 harness 20" Loom from Northwest. It did take a mighty wait before we got it, but we think it was well worth it. The looms are beautifully constructed—there are evidences of care/thought/love in the loom. They are faster and more convenient. The company was responsive immediately to a complaint (wrong number of heddles) we had, and now the loom is outfitted and has produced several projects.

Please retitle item "trouble-well-worth-it looms".

Love,  
Jim & Nancy Cox  
Pacific Grove, Calif.

## Oh Dear

Dear People:

My two Perma-Pak Karry-kits I purchased from you you did not contain can-openers. Rocks are *not* efficient in this function.

Peace:  
Please & Thank You  
The Wood-Runner

## Music Synthesizers

Concerning Music Synthesizers. I have been using Moog stuff since 1965; I have some of the first Voltage Controlled Oscillators and Voltage Controlled Amplifiers that he made. All are still working, though they have been returned twice for factory adjustment. My more recent Moog acquisitions have proved equally satisfactory. The great thing about Moog equipment is that you can start with individual modules and slowly build up a system: power at first can be from a six and twelve volt car batteries hooked up to give plus twelve and minus six volts. Intonation was a problem with the Moog oscillators at first (even worse with Buchla) but this is no longer such a problem.

The Buchla is easy to use and produces instant tunes via the Sequencers, but in most hands produces cliché music. One can always recognize the commercials that have been made on the Buchla.

The Tonus ARP synthesizer really has not proved itself yet. The two advantages (they say) are more stable oscillators and Matrix switching which does away with the necessity of patch cords. But since Moog stuff is now in tune enough, and I like patching I can not see the advantage of the ARP. Also with the use of ICs ARP has made some of the modules AND KNOBS so small as to be difficult to manipulate.

I cannot take the Putney seriously; it is a mere toy and a waste of money to my mind.

For a cheap synthesizer I would recommend the ElectroComp which was developed for the Connecticut public schools as a training unit in Electronic Music. The basic unit has a Master Oscillator, two voltage controlled oscillators, a noise generator, high and low pass filters (not voltage controlled), Ring Modulator, Reverb, Mixer, Mic Amp etc and is contained in a box two feet wide, 16" high and a foot deep. The PRICE \$999.50. Write to: Electronic Music Lab.

Electronic Music Lab.  
P.O. Box 1334  
Hartford, Conn. 06101

Robert Ceely  
Brookline, Mass.

## Miscellaneous

Concerning laminite cardboard from TriWall Containers, Inc.: After three letters—no sample, not even a reply.

Concerning concrete manuals: no longer available from Skokie, Ill. Only available from your local Portland Cement dealer.

Also, have not been successful in obtaining catalog from Plasticraft.

John M. Stoddard  
Gulfport, Fla.



## Crunch, Crunch

We have not read all of the supplements so we don't know if you have have printed recipes for crunchy granola. If you haven't—here is one: MIX

- 4 C rolled oats
- 1 1/2 C shredded unsweetened coconut
- 1 C wheat germ
- 1 C chopped nuts
- 1 C hulled sunflower seeds
- 1/2 C sesame seeds
- 1/2 C flax seed
- 1/2 C bran
- 1 C ground roasted soybeans

HEAT—

- 1/2 C oil (soy, sesame or corn)
- 1/2 C Honey
- 1/2 t vanilla

ADD

honey-oil mixture to dry ingredients and mix (mixture will be very dry)

SPREAD

mixture on oiled cookie sheet or jelly roll pan (cookie sheet with sides) & bake at 325 degrees about 15 min. until light brown.

All measurements are approximate and it's nice to improvise with ingredients, too. However, you make it, it will be much, much better than any commercial varieties.

I would like to know of good books on vitamins, lecithin, pollen, ginseng, jujubes, etc. (I can't even spell them but am interested to know what they do for you.) Everyone I ask explains them a little to to esoterically for my plasticized head.

Thank you.

Philip & Elizabeth Schnazerson  
Berkeley, Calif.

## Vitamin E

about burns (July \$1 catalog, pg 47), last november the gas stove in the place we were renting blue up and messed up my arm. In some places it was pretty bad (black and flaking away by the time i got to the hospital) and it hurt. i was given a shot (5 mg morphine) and the started splaching the arm with phisohex and cool water. The dr also told me to plan on skin grafting because the elbow was bad also. my old lady told me about vitamin e and i sqused some under the bandage, took 3-4 grams a day with the same of vitamin c. IT WORKS. The only signs of the burns left show up on those occasional times when a dr gives me a through phiscal.

I forgot to say that the 3-4 grams was saved under the bandage. I think that the oral dossage also may be important getting the stuff into the system, there by getting to the burn several ways and making it available over a long time, but I don't know.

I know a couple of women who squeezed Vitamin E from the capsule onto their stomachs during & after pregnancy to prevent stretch marks. They also exercised a lot & didn't get any stretch marks. We'd like to know more including natural sources for Vitamin E.

john mccarthy  
denver, co.

## ALGAE AS FOOD

BONN, August 1—A joint project begun this week by West Germany and Thailand forsee the cultivation and processing of protein-rich algae as a food on a large scale.

Initial experiments by the Carbobiological Research Station in Dortmund show that single-cell algae can be collected, dried and reduced to a powder that provides a basis for nutritional soups, crackers, and puddings.

The Dortmund scientists have already successfully tested their green powder as nourishment for hospital patients suffering from a lack of protein. The algae they have been using contain 51 per cent protein and all the basic amino acids. Recently the Federal Minister of Development Aid, Erhard Eppler, demonstrated to journalists that the bright green powder could be made to taste good. He smiled broadly after swallowing some.

Under an agreement with Thailand, West Germany is to provide more than \$300,000 in technical aid for algal-food experiments in South-east Asia.

The Dortmund scientists are to work with Thai scientists from the Institute of Food Research and Product Development of Bangkok for the next three years. They hope to establish acceptability criteria that would stimulate the production and consumption of algal food. Dr. Carl J. Soeder, director of the Dortmund research team, said the Germans wanted to see whether the single-cell algae originating in fresh waters here can be cultivated in the tropical climate of Thailand.

In parts of northwest Thailand, multiple-cell algae, or fresh water weeds, are already used as food by the native population. Dr. Soeder explained that single-cell algae grow much faster than their multiple-celled cousins.

—N. Y. Times

### Life, Death, Karma

My wife and I recently went through a sad unfolding of karma from which we have learned much. We hope that we can share some of our findings with W.E.C. and its readers.

On June 19, my wife, then seven months and one week pregnant, began hemorrhaging. I took her to the hospital, fifty miles from here, and seven hours later, the doctors delivered our first child, a boy, by caesarean section. The infant was born with a severe respiratory disorder, and despite all out efforts by the doctors and nurses, he died five days later. Needless to say, we were heartbroken and faced with the problem of a funeral. I called a friend, Anton Nelson, who had written a short piece for the W.E.C. supplement last spring on inexpensive burials. My wife and I were opposed to paying some unctuous professional from a funeral home to handle the burial of our baby. Anton advised me on the steps I needed to take and cautioned me that I should be prepared for the same "back-room professionalism" of the funeral director's job. Rather apprehensively, I proceeded.

- (1) Obtain certificate of death from the Bureau of Vital Statistics, have doctors fill in information and sign it. (Some doctors have these certificates in their offices and complete them and send them to the Bureau of Vital Statistics.)
- (2) Return to the Bureau of Vital Statistics and obtain a permit to move the body.
- (3) Pick up the body at the hospital, (which I put in a plywood box I had built earlier) and take it to the crematorium.
- (4) In order to get a permit to dispose of the ashes, the crematorium needed the name of a cemetery where I was going to bury the ashes. (I remembered the name of a cemetery where a cousin was buried and gave them that name. There was no further hassle.)

A week later I picked up the ashes from the crematorium. The total cost was sixteen dollars to cremate the baby, and six dollars for six white roses, five of which were placed in the box with the baby and one given to my wife.

I would like to add that at no point of the proceedings did I encounter any hassle. I was usually asked what funeral home I was from, and when I replied that I was the father and was taking care of it myself, no one seemed to be shocked and everyone seemed to make an effort to help. There seemed to be a lot of respect for what I was doing.

Last week a friend and I backpacked into the central High Sierra and strewed the ashes on top of Mt. Goddard. Thus ended our first experience with birth and our first experience with death. My wife and I hope this account will help others who may someday encounter this misfortune.

Sincerely,  
Kip & Donna Hillman  
Oakhurst, Ca.



Steward Clifford, a leading expert on high-risk pregnancy, states: "it should be emphasized that in every case the identification of the high risk patient should be possible at the initial examination and at various times in the prenatal course and before labor and delivery." What are these risk factors and how can they be recognized?

First there are demographic factors. Women over forty or first pregnancies over 35 are more risky than average. Low education levels and low income are also high risk factors, even when good medical care is obtained.

Next is prior obstetric history: first births are higher risks as are fourth or greater. Infant mortality is high for patients with a previous abortion or ectopic (out of the womb) pregnancy; it is even higher if there is a history of previous premature births (weighing less than 5 1/2 lbs.) and higher still for those women with a previous history of stillbirths or neonatal deaths. A history of a large baby (greater than nine pounds) or a baby requiring transfusion is also a danger signal. Prior high blood pressure, marked swelling of hands and ankles, or protein in the urine during a previous pregnancy are further cautions.

Any woman with heart disease, diabetes (or a strong family history of diabetes) or any kidney disease should be followed closely by a doctor throughout pregnancy and delivery.

During the pregnancy there are also warning signs which preclude home delivery. Without attempting to explain the disease entities involved, suffice it to say that any vaginal bleeding after the first month of pregnancy (except very slight spotting or "show" at the beginning of labor) or any report of high blood pressure is sufficient to necessitate specialist care.

As delivery approaches there are more clues, including rupture of the bag of waters before the onset of vigorous labor; labor beginning before the thirty-eighth or after the forty-second week of pregnancy (counting from the first day of the last menstrual period). If nothing has gone wrong up to the onset of labor, but labor has progressed for eight hours without births being imminent, this is another indication to rush to the hospital.

In summary, if you are between twenty and thirty years of age, a high school graduate with a fair income and good nutrition, with one or two but not more than three previous uncomplicated births, and no medical problems, you might begin to consider home delivery as an acceptable risk. Your first step toward success is to have adequate prenatal care (mortality is much higher for women without prenatal care, mainly because of avoidable complications) beginning no later than the third month of pregnancy. You will still not be completely safe from unexpected complications, but you will have reduced the risk to proportions where the benefits to you and your family from home delivery may—for some families—be great enough to make these risks acceptable. But to fail to reduce the risks through prenatal care or to ignore any danger signal is to not only invite disaster, but also to bear the responsibility of knowing you didn't do all you could to avoid the disaster.

Bruce Ferguson, M.D.

### Babies At Home: A Calculated Risk

Many situations in medicine involve attempts to balance the costs and benefits of one possible course of action or inaction against the costs and benefits of another possibility, and to choose the alternative with the lowest cost/benefit ratio. Unfortunately medicine has often ignored psychosocial benefits to the patient and over-emphasized personal benefits and convenience to the doctor. Child-bearing is one such situation: the psychic benefits to the whole family of being present at the birth of a new child has largely been ignored, while the convenience to nurses, anesthetists and doctors has been over-emphasized. One result of this has been the "backlash" of interest in home deliveries, usually without the doctors approval, much less with his help. Without attempting to assess the psychic value or reduced economic cost of home deliveries, I would like to clarify some of the risk variables involved.

In the best of situations, it can be expected that about 3 to 4% of deliveries will result in either a stillbirth or a child who dies during the first week of life. This figure can result in optimism—over 95% of women will have few problems—or pessimism—nearly one in twenty women will have prenatal death *no matter how good their care*.

Because of this situation, such generalized statistics are worthless to the woman thinking of having her baby at home. Adding to the confusion is the knowledge that British and Dutch women routinely have their babies at home with apparent success judging by their lower overall infant mortality than ours. Their success however is dependent on the statistical knowledge of which situations are likely to be complicated—necessitating hospitalization and specialist care—and which are very likely to be uncomplicated—necessitating only routine measures available to a midwife in the home.



CRYING is language. Respect it.



It's important to talk about some of the changes that occur in people—especially younger people from one of the urban subcultures or movements—when they move from city to country. What follows admittedly lacks rigor. It is based on relatively small numbers of observations. The move almost always issues from the recognition that the cities in their present forms are doomed. Almost always the goal of the people in their new rural surroundings to become independent of the obsolescent, tottering money system; at first this goal seems impossible to achieve (thus much suffering and quarreling); but as the possibility of such self-sufficiency returns, another large consciousness shift occurs: Not by bread alone: what should my culture be? Only a few elements of current urban cultures can be transferred.

The difficulties encountered in attempting to create one's own culture in a short space of time are staggering—and most understandably the early answers are regressive. At present in the Southwest the most popular regressive answer involves an attempt to imitate the 19th century Amerikan small-farm-on-the-frontier trip: skirts down to the ground for the women (preposterous waste of fabric & implications of flesh shame etc), glorification of big families, mawkish

attitudes toward children and pets and a very plain—drab, really—style.

It will take shaman-poets to pull it all together and provide a progressive answer. What gives the attempt special poignancy is the near certainty that the emerging culture of the next 10-30 years will be the last culture before a long "post-historic" period of man—or more accurately a long period between this history of man and the next.

The feeling that our lives have been foreshortened, that few of us are going to make it into old age, underlies most of the deepest divisions and disagreements among the country newcomers. Already there are "polarizations"—and almost always they issue from two different attitudes toward the imminence of death. One kind of person will wish to continue to take chances even on the edge of the abyss and the other will struggle to live all the way into old age despite the actual probabilities. In some cases the attitudes represent more vacillations within a single person and in other cases they can lead to the brink of shoot-outs among people who had considered themselves brothers in one of the earlier suburban contexts. Large unforeseen tensions, then, between the longevity people, and, say, the apocalyptic people.

You might expect to be able to predict who will take which side on the basis of which urban movement or subculture had been most closely identified with—but you can't. Death is that intimate. One does find that people who had been arrested ("educated") in one of the earlier urban contexts usually will evolve into an apocalyptic life-style.

Those who strive for longevity generally retreat into the shell of the nuclear family and lean in heavily on traditional consolations like children and pets. (We even know one longhair nuclear family which observed Mother's Day this year.) They tend to worry more about what their rural straight neighbors think of them—and to be more willing to imitate aspects of rural straight value systems. (At their worst these imitations can lead finally into attending local church services as part of a gimmicky dishonest community relations program.) Thus the longevity people usually base their special occasions on lunar or solar positions. Longevity people break fewer laws, seldom do numbers.

The central contradiction in the longevity trip is that in the process of stretching your life as far as it will go you risk becoming so boring no one wants to grow old with you.

From Newsweek

April 6, 1970

"The city person usually asks me to spare no expense in order to keep a dying relative alive," observes Dr. Robert Leachman, director of cardiology at St. Luke's Hospital in Houston. "But the rural person who has lived his life in close contact with the cycle of nature accepts death more readily as a fact of life." . . . at one Boston hospital, . . . Kastenbaum found that the terminally ill had dubbed their wing "Death Valley." the dying were kept alive with drugs till their machine ran out. In time, however, the psychologist was able to cut the use of drugs by introducing a simple humor touch: once a day, the residents of Death Valley were allowed to throw an old-fashioned beer party.

from:  
Earth Read Out  
ero/sw  
Box 1048  
Las Vegas, N.M. 87701



THE DURATION OF THE  
EARTH



Our final culture probably will have to contain (as certain Eskimo and Indian cultures have) ceremonies of death to be entered into voluntarily by the aged. On a planet so crowded we probably cannot live out the three-score-ten we've been conditioned to expect; we shall probably have to remove ourselves at two-score-ten or even earlier. The culture will have to evolve an agreement that living more than a certain number of years is thoughtless.

The old straight Amerikan culture probably instills a greater fear of death than any other; a study of Buddhism is perhaps the best antidote for the fear. Charles Manson provides a striking description (*Rolling Stone*, 6/25/70) of the internal leap past death-fear, past what Buddhists call "clinging:"

Once I was walking in the desert and I had a revelation. I'd walked about 45 miles, and that is a lot of miles to walk in the desert. The sun was beating down on me and I was afraid, because I wasn't willing to accept death. My tongue swoll and I could hardly breathe. I collapsed in the sand. Oh God! I'M going to die! I'm going to die right here! I looked at the ground and I saw this rock out of the corner of my eye. And I remember thinking in this insane way as I looked at it, "Well, this is as good a place as any to die." And then I started to laugh. I began laughing like an insane man, I was so happy. And when I had snapped to, I realized what I was doing. I'd let go. I wasn't hanging on. I was free from the spell, as free as that stone. I just got up as if a giant hand had helped me. I got up with ease and I walked another 10 miles and I was out. It's easy.

from:  
Earth Read Out  
ero/sw  
Box 1048  
Las Vegas, N.M. 87701



**how to use an ax, or anarchy as the solution to oppressed womankind's problems or the female revolutionary as true artist or the true artist as the female revolutionary**

rose was in the shower singing "i left my love in the Malay Bay" when he knocked on the door. It was Jim and Rose knew it. She had been expecting him since the night before. Rose was Jim's home port girl, rather she was his steady home front woman wine, which meant that whenever his ship pulled into the old recognizable cheery familiar grey navy docks from where he originally left, he put his aftershave and deoderant into his leather bag and disembarked straight for Rosie's second story place, with a bit of 1940's movie suave, picked up when he was 10, Jim saunters up the side steps and pushes the bell button, to bring us to where we are in this accounting. And Rose, the reason she knows it is her Jim there on the other side of the door, is that she received a post card in the mail two days ago with a picture of a southasian monkey scratching himself and on the back a message scrawled in red ink: home is where you can \_\_\_\_\_ whenever you're itchin'.

This was Jim's secret message which led Rosie to lie awaiting his immanent return. She had tucked the post-card discretely between the pages of her cookbook and Jim caught a side view of it as he surveyed the kitchen (he showed himself in and was working his way back toward the bathroom which was located at the rear of her skinny apartment) and leaned his ear toward the sounds slipping under the bathroom door. Rose my sweet you sing like a silver flute like a trout under a waterfall, ah he sighed under his breath. The water sound stopped behind the door and Rose's voice came sifting through the silence. "Zat you Jim?"

Now Rose never was one to be caught unprepared, so she had spent all morning shining her pots with copperchrome to a perfect shine. She had taken everyone and arranged them strategically though not unsymmetrically nor without taste in arrangement around her kitchen, so that the moment after she appeared from out of the bathroom doorway clad braless and fetching in her black mini slip, she was armed, waving her saucepan around her head feet anchored wide for balance, leaning back with a gut yell she let it fly. Jim, unfortunately, ducked in time, thereby saving himself for further attacks and letting the pan crash into the pasteboard wall behind him, where it made a moon-shaped dent, nor was Rose one to waste time and grabbed another pan before the first one she let fly had arrived at the wall. this time she stalked jim, who, caught unprepared for this attack, was alternately scared and dumbfounded, he assumed a crouching position to express this mixture of feelings. Using the corner cabinets for a backdrop he attempted to shield himself with what was the only readily available device the dishdrainer, pottery splattered on the floor as he yanked the drainer off the countertop, with her left, she hurled tin after tin some through the window hole, some bounced off jim, then closed in on her crouching victim and poured pot after pan upon him until they were arranged in an astonishing and shining heap, forming such bold asymmetries, such original oblique patterns as to boggle the mind of even the most genius of all up and coming art critics. The sun coming in from the broken window struck on the aluminum curves so as to make the whole pile seem like a perfection in convex/concave dark/light studies in opposites. DON'T move! shrieked Rose at her Jim, who at this time was laying with only his knees exposed and his mouth hanging open to utter a rasping whaaaaaaat.....

-r. wakeland



**"It Was 50 Years Ago, Today"**

Nor do I need to pray for courage to join a riot, throw stones, scratch faces, tear clothes, or anything else that comes along in the course of defending my ideals. That courage was born in me as my woman's heritage of the ages and trained by every tradition of my personal life and of the South.

Here is the important point, it seems to me, the men and the antis are all missing in the psychology of the present stage of the suffrage movement, particularly as it is manifesting in England: When driven to despair of the use of milder methods—despair of argument with a wolf or moral suasion with a snake—we start in fighting, nerved and spurred to it by one of the oldest instincts in the world: defense of our offspring of body and brain. The instinct has never changed, and may Heaven defend us from the woman who isn't womanly enough to stand up and fight, regardless of self-interest, for the thing she loves! The woman who isn't willing to isn't a woman at all, she's only an apology in petticoats.

Realizing this now, I frankly glory in being "a creature of instinct." It makes me feel consciously allied, as I never did before, with the whole living world, one with its primal forces, partaker of its progress, assistant creator of its coming achievements.

from January 25, 1913 issue  
Saturday Evening Post  
"The Evolution of a Suffragette"



**The Motherhood Myth**

The younger-generation females who have been reared on the Myth have not rejected it totally, but at least they recognize it can be more loving to children not to have them. And at least they speak of adopting children instead of bearing them. Moreover, since the new non-breeders are "less hung-up" on ownership, they seem to recognize that if you dig loving children, you don't necessarily have to own one. The end of The Motherhood Myth might make available more loving women (and men!) for those children who already exist.

When motherhood is no longer culturally compulsory, there will, certainly, be less of it. Women are now beginning to think and do more about development of self, of their individual resources. Far from being selfish, such development is probably our only hope. That means more alternatives for women. And more alternatives mean more selective, better, happier, motherhood—and childhood and husbandhood (or manhood) and peoplehood. It is not a question of whether or not children are sweet and marvelous things to have and rear; the question is, even if that's so, whether or not one wants to pay the price for it. It doesn't make sense any more to pretend that women need babies, when what they really need is themselves. If God were still speaking to us in a voice we could hear, even He would probably say "Be fruitful. Don't multiply."

From "Motherhood—Who Needs It?"  
By Betty Rollin, Look Senior Editor  
Look Magazine, Sept. 22, 1970

she: why you yawn every time i start to talk about anything?  
he: (yawning) that's ridiculous.

Dennis: The trouble with you Margaret, is you think you know everything.

Margaret: I know a lot of things you don't know!

D: Well, I know something you don't know!

M: What's that?

D: I know you don't know as much as ya think ya know!

D: Don't pay no attention to Margaret, Tommy, she's a DUMBELL!

M: Well, You're an ADDLE-BRAINED IMBECILE

D: Oh, yeah? Well you're a BONE-HEAD

M: And You're a DIM-WITTED DOLT!

D: You're a DOPEY NUMSKULL!

M: You're a BRAINLESS IDIOTIC INCOMPETENT!!

D: Yeah? Well, you're a... a...

M: You can't get the best of me, Dennis, I know too many words!

D: Well, you're even worse than all them things you said I was!

M: Oh? And what could possibly be worse than Those things?

D: You're a... a...

M: I'm waiting. Go ahead, what am I?

D: You're a... a... GIRL!!

Tommy: Boy, you sure told HER!

Yeah Yeah. With all her big words she can't top that!

from Dennis the Menace, by  
Hank Ketchum, San Francisco  
Chronicle, Sept. 13, 1970

"why don't you come to our women's lib meeting?"  
"my husband won't let me."

## Women in Communes

"In education, in marriage, in everything, disappointment is the lot of women. It shall be the business in my life to deepen this disappointment in every woman's heart until she bows down to it no longer." — Lucy Stone, 1855

The first time I picked up an ax, I felt a sense of failure. Twenty-two years of inactivity, a few isolated attempts—pretending to paint the house with water while my brother, who was only a year older than I, did the real job; or being told to do the dishes instead of mowing the lawn.

What I have learned about the ax is true of most kinds of physical work; use your head, and the ax does the work for you. I learned to hit the log first at one angle, then at another, forging a "V" into the trunk. I learned that the thicker the log, the wider the angle had to be; that the ax should come down of its own weight, guided by the hands, and that the arms and body should follow through, just as in swinging a baseball bat. The first day it was hard work—I kept missing the log, and I got tired very easily. The second day was not so bad. Now I'm no longer afraid of the ax. There are different kinds of weakness—the kind that grows in the mind, the kind that the body feels if it never has been used—and the weakness of bullshitting yourself by assuming you can't do something.

The world we live in moves so incredibly fast that it is very easy to avoid asking what we can do, and more important, what we like to do. Conditioned we are—for instance, any woman who lives in the city can pretty well write off needing to use an ax. And most white middle class women (and men) assume that such activity is beyond the scope of women's potential, calmly ignoring the trusty old pioneer women, the women in rural areas who still chop wood every day—and even the ones who live in the less affluent part of the city, who more often than not work a hard day to earn a wage that barely supports a family, then work as their own house-keepers for no pay and no recognition. The assumption that women are "weak things" is a middle class luxury. For lower class women, the opposite myth is more convenient—women are good at tedious (and physically difficult) shit work.

Certain tasks have to be done every day in nearly every living situation (although we often exaggerate addenda into the essential; furniture wax is both a luxury and a cruel oppression.), but this world never offers a us chance to "start again," with a lump of labor and a group of undifferentiated human beings, so that everyone can decide what he or she really prefers to do, and in the process become not just man or woman, but human.

Something approximating such a chance occurred this summer for a small group of people living on a farm commune. There were twelve of us, give or take a few, for most of the summer, doing work which consisted of planting, weeding, pulling trees, and harvesting, as well as chopping wood, cooking over an open fire, washing clothes, and keeping the tents and the camp clean. There

was no running water, which made housekeeping chores a little more difficult, and no electricity, which meant that some of the work, like washing the dinner dishes, was usually done in the dark.

Even though there was no society-dictated division of labor, even though we had complete freedom to determine the division of labor for ourselves, a well-known pattern emerged immediately. Women did most of the cooking, all of the cleaning up, and of course, the washing. They also worked in the fields all day—so that after the farm work was finished, the men could be found sitting around talking and taking naps while the women prepared supper. In addition to that, one of the women remained in camp every day in order to cook lunch—it was always a woman who did this, never a man. Of course, the women were excused from some of the tasks; for example, none of us ever drove the tractor. That was considered too complicated for a woman. We never would have had to haul wood or chop it if we hadn't wanted to.

Does this story sound exaggerated? I think it is true that even men who verbally condone the liberation of women would tend to react the same way in a similar situation, as the result of conditioning. It is true that to some extent our group was free of the dictates of society last summer—but of course we weren't free of our cultural conditioning, which exists outside the society's institutions, and is, in fact, embodied in the individual. The men in our group were exhibiting a collective system of belief based on early training.

The women, too, had much to overcome, and we had to consciously organize ourselves to face the oppressive conditions which we were partially responsible for creating. We were a minority, and most of us were unattached; we were all between the ages of fifteen and twenty-four; all of us had thought and read, in varying degrees, about the problems which women face. We began holding private caucuses in the woods, far enough from camp so that we could feel free from any stray masculine ears. These meetings were not held in secret, though we said little about them, but they were considered a declaration of war by the men in camp, and in a sense we considered them a sign of secession from the normal order of life as pre-determined by the men, and by our own maimed outlooks.

In the meetings we discussed day to day experiences in the camp, related them to what we had gleaned from the past and the condition of women in general, and began to educate ourselves by reading and sharing general knowledge. Our strategy was a total re-orientation of our images of what we could and could not do.

One of our tactics was complete non-response to hostility on the part of the men. We had to learn to differentiate between legitimate attempts to discuss women's liberation, and sheer harassment. To the former we would willingly respond; the latter met with neutral silence. In order to forcibly shift the division of labor, we began doing other chores around dinner time. Collecting and chopping wood was an activity which was often neglected in the course of the day, so after our regular farm work, we would turn to the wood instead of the pots. We tried to discover and do things that

needed to be done for the maintenance of the camp—building rather than cleaning.

If a tense situation arose, where a sister was uncertain how to react, there was usually another sister nearby, and a smile, a hand on the arm, or just the knowledge of concern, helped everyone keep calm. We felt that consistency and complete discipline in regard to our willingness to work were of utmost significance in showing the males that our intent was not to humiliate them, but to work toward a more healthy environment for everyone concerned.

Our experiment was a colossal failure. In analyzing what went wrong, it is probably unfair to place the blame on the men's inability to understand. Yet, as a woman, that is the only conclusion I can come to. A lot of dusty old myths were dragged out and shoved in our faces... you don't work fast enough; a man can't even get a decent meal around this place unless he cooks it for himself; before you learn to drive a tractor, learn to get the dishes clean (I don't want you fucking with my tractor, baby); is there something wrong with your sex life? you want to be just like a man...

For several weeks we lived in two separate camps. If we went gathering wood at dinner time, the men cooked—for themselves only. They washed their own dishes, but never the pots and pans that the food had come from. In the field we were a separate women's brigade—all day we worked together and talked liberation, separate from the men.

Those were happy days! Left alone, we taught ourselves, feeling free to be clumsy at first, knowing that we wouldn't laugh at each other. I think we all began to develop confidence in our ability to do things, and my own physical endurance increased tremendously—I had no reason to let a man take over, ever. I think my sisters and I learned to love and value each other as women seldom can when they are divided from each other and forced to compete for recognition by the men in their lives—forced to compete much in the same way that capitalism forces men to compete against each other. In each case, it is the best position in the pecking order that determines how people act toward each other.

The fact that half of the women involved with the farm commune project are no longer there, and that the other half are consciously compromising in order to insure the success of the farm, is a testimony of the long fight which we all face. The inability of men to respond to our attempts to liberate ourselves seems to be an indication that now is the time to isolate, to learn, to build, and if necessary, when we have the strength, to force a change that must come if we are to be free. Cultural change, through the breaking of boundary conditions on behavior, will have to occur, and can only occur, through a conscious re-orientation of our own self-images.

By Kit Leder  
Originally Published in  
*Women: A Journal of Liberation*  
(for access see Sources below)

j.d.'s grandpa says, "when you find biscuit dough on the ax-handle, you know the honeymoon is over."



"He: Why don't you come up to my place and see my whole grains?"

## From Sara

Dear Friends (I was going to say "sisters": but got embarrassed by the vocabulary. Just like I can't say "right on" without feeling like Time magazine)

The gears are sort of shifting around and this letter is mostly process, a working out of the things that've been on my mind since I read (and gratefully, to thank you ) your back pages in the July catalog.

Some things:

1) Yeah, I guess maybe one of the main reasons why I can't stand hippies is that they seem to be out to prove, with a vengeance, that male chauvinism isn't dead. In the commune, or street scene, or whatever, if it isn't, "Hey, Chick, get me a cuppa coffee," it's "Women are really closer to nature—they're gentle and intuitive (he means "dumb"), soft, good with animals, children, etc. . . Women really know where it's at (he means "They know their place")." Their place, in hip society, is straight out of pioneer days—women bake bread, sew, weave, cook, clean, shut up, and serve the menfolk. Sure they like it. Sure that's "the natural way" Uh huh. The niggers were happy on the plantations, too.

## 2) Women-as-Artists

I feel pretty competent in my crafts—photography and videotape; and as a word artist—but I had to take a lot of shit to get there. It's just an incredible drain on creative energy to have to be on the defensive all the time.

3) Which is how I'm sounding—defensive and bitter and vengeful; I don't want it that way. God knows, it's gonna be no big improvement just to have women in charge for a change, the way we lust after power and give every indication that we'll abuse it in the same way men have. It's like thinking revolution means the Democrats win instead of the Republicans.

Together we humans have got to come up with some better way of running things. Like cooperation, maybe. (Or prayer, if it gets that desperate . . . think about it—what sex is God?)

Love,  
Sara Miles  
34 Sparkhill Ave.  
Tappan, NY 10983

hey, I would really like to hear from anyone who feels like corresponding.

## Sources For Info, Materials, Groups

CHICAGO WOMEN'S LIBERATION UNION, 2875 West Cermack Rd., Chicago, Ill. 60623; 312-927-1790, is a coalition of over thirty Chicago-area women's liberation groups.

CRIMKE-BROWN COALITION, c/o Carol June, 40 North Ashland Ave., Chicago, Ill. 60607, or Frank Adams, 214 East Clay St., Richmond, Va. 23219 (co-chairpeople), is an information exchange center and talent bank working to link groups and individuals in the feminist and anti-racist movement.

NATIONAL ORGANIZATION FOR WOMEN, Southern California Branch, 9601 Wilshire Blvd., #22, Beverly Hills, Ca. 90210, published a newsletter each month about their struggle to end sexual discrimination in the professions: cost, \$5.00 a year.

NATIONAL ORGANIZATION FOR WOMEN, P.O. Box 114, New York, N.Y. 10025; 212-663-1686, is currently most concerned with issues regarding employment discrimination for women, and legislative things such as the equal rights amendment. They are also active in abortion law repeal.

NEW ENGLAND FREE PRESS, 791 Fremont St., Boston, Ma. 02118, has printed a wide selection of pamphlets on women's liberation, among them: *The Politics of Housework*, *Female Liberation as a Basis for Social Revolution*, *Psychology Constructs the Female*, and many others. They cost about 15 cents per pamphlet.

SOUTHERN FEMALE RIGHTS UNION, Box 30087, Lafayette Square Station, New Orleans, La. 70130, wants to work as a center coordinating women's work in the South.

WASHINGTON, D.C. WOMEN'S LIBERATION, Box 13098, Washington, D.C. 20009, is a distribution center for the Women's Liberation Movement.

WOMEN: A BIBLIOGRAPHY, by Lucinda Cislser, 102 West 80th St., New York, NY 10024, is a 16 page annotated reading list. It is divided into 14 categories and was revised in September, 1969. Costs are 25 cents per copy, \$2.25 for ten, and \$5.50 per thirty. Foreign orders please pay in US currency, and add postage to cover air or surface costs. Each copy weighs one ounce.

WOMEN: A JOURNAL OF LIBERATION, 3011 Guilford Ave., Baltimore, Md. 21218, is published five times a year; each issue explores a different aspect of Women's Liberation. Subscription rates: \$1.25 for a single issue, or \$5.00 a year.

WOMEN'S HISTORY RESEARCH CENTER, INC., 2325 Oak St., Berkeley, Ca. 94708; 415-524-7772, is a research lending, corresponding, and selling library of women's literature: books, periodicals, pamphlets, articles, tapes, etc. A running catalog includes addresses where information is available at cost from other groups so you won't have to start from scratch. A synopsis of women in world history is available for \$1.00 including postage; information on the suffrage movement in Western Europe is 15 cents to individuals, 20 cents to institutions.

WOMEN'S LIBERATION NEWSLETTER, PO Box 116, Cambridge, Ma. 02138 . . . it's exactly what it says it is!

—From *Vocations for Social Change*  
Sept.-Oct., 1970  
Published bi-monthly  
Canyon, California 94516 (415) 376-7743

## Diana's Rap

I successfully avoided dealing with the whole women's lib question for months. Faced with the necessity of working on these pages, I sat myself down and read Time's spread, and Life's and a bunch of other stuff. And I came to realize why I'd been avoiding it. I've been relating to all kinds of far-out movements for years, but this time, I couldn't identify. Sympathize, empathize, yes, but the evening's reading left me feeling terribly sad and alienated from a scene that somehow should be my scene too. Nearly all the literature refers to the rare exception—the woman who has somehow "overcome" all these cultural patterns and makes her own decisions, leads her own life, does her own thing. Well, I don't at all enjoy feeling like an "exception", and I was never aware of overcoming great obstacles—male or otherwise. I've simply been leading my life and making my choices and sort of assuming everyone else was too. I have been: —a secretary, —a lab technician, —a clinical social worker, —an encounter group leader, —a wife (for one year), —a student (for six years), —a lover (-ess?), —a political activist, —a probation officer, —an editor (tress?); —paid less, always, than my male counterparts. I haven't ever been: —pregnant, —married for ten years, —a mother, —a full-time housewife, or lots of other things which I realize form some of the experience from which women's lib springs. I'll be 30 next year.

I have also never felt completely satisfied and fulfilled as a woman and as a human being. Neither has anyone else I know, and that includes men. I do remember once a woman I was working with confronting our male co-workers with a very passionate plea, "You see me as a woman, as a mother, as a little girl, as a this, as a that—I wish you'd remember I'm a HUMAN BEING!". It blew my mind, and I jumped in with my, "I feel just the opposite—you see me as a competent, talented, strong, and you forget I'M A WOMAN". Whereupon I burst into tears, having meant, of course, "I'm JUST a woman; I shouldn't HAVE to be as strong as you are; I need also to feel helpless, dependent, and weak sometimes".

Well.

I dig women's lib very much and appreciate a lot of what it's all about, and I find myself being affected by some of the thinking that's going on. I don't dig large parts of it—having spent a lot more of my life in the conventional "men's world" than in the conventional "women's world" (i.e. at home), I suspect a lot of women of over-romanticizing "the world out there". Thousands of men's jobs are at least as boring, tedious, repetitive, non-creative, and unsatisfying as housework and diapers. Nearly always there's less opportunity for physical movement during the day, for doing different things on different days, for listening to music while you work, for taking a nap, or doing a dance—in the "men's world". I have longed—get this—for the freedom of being able to regulate and choose my own schedule to some extent. For possibly having sometimes four hours to prepare a feast, when the mood strikes, instead of the hungry, post-working day quick supper. I have certainly over-romanticized the life I've never led—husband that will take care of me and deal with all that "business", babies, etc. The current sweep of women's lib inclines me a lot less toward these indulgences, and that's probably what I most appreciate. That and the theme that "this is bigger than the bot'n us"—that men suffer from their cultural roles at least as much as women do, and that the real problem lies deeper—lies, in both cases in a society and family structure which makes it very difficult for anyone to realize his full potential, or even any very close approximation.

On one level, I simply lucked out. With three sisters and no brothers and a father who is no sort of male chauvinist, I always felt there was plenty of room for me to define my own role, without a whole hell of a lot of respect for convention. I live in a commune now, with 5 men and 5 women, and we all take turns cooking. The women tend to clean up more, but the men always take out the garbage & take care of the yard. Various of us work at various times, and perhaps our strongest implicit goal is for everyone to be able to live the way they most want to, within our "family structure", and within the recognition that everyone has to do their share of the chores. The sisterhood between the 5 women is the strongest

and most profound I've ever experienced—I think the same is probably true of the brotherhood of the men. I can't deny that we've all been affected by our cultural conditioning. Perhaps all I really want to say is that changes are being made, right here in river city; sympathetic male ears are available—my god, the last thing our men want is a bunch of submissive drudges around the house. Which isn't to say they aren't capable of feeling threatened by us. I experienced very peculiar feelings myself when I walked into the kitchen and saw one of my "brothers" cleaning out the refrigerator, and whistling like a lark, grinning to himself, muttering and wondering what had got into him, and really enjoying himself thoroughly. What I love most about the commune is that I feel like I can be whoever I want to be—I can wait on the men (and the women, too, for that matter) and take great pleasure in it, and I can also argue with them, be hostile, be loving, be submissive, be rebellious, do someone else's thing, do my own thing, participate in our communal vision, etc. Just like a family should be. See, the thing is, I suspect that lots of women could do all these things with their families too, if only they would. Your freedom is often, or largely, as much as you have the courage to grab for yourself. Which is to say, mine has been. And which isn't to say I can always do any, much less all, of the above. I figure I have a pretty tolerant environment, though, and it's my responsibility to get it on for myself. With a lot of help from my friends. Ok.

—Diana



Line Drawings by Meta Sylvester

## From Phyllis

Dear Pam/Smith and people,

I'm a woman. I do art things. I don't know a damn thing about women or a damn thing about art, but I do know about myself. Sometimes. Anyway, here's some miscellaneous stuff written during the last few years, some of which may be relevant to women, art, and women-as-artists or would-be artists. Besides getting into snits and writing a whole lot of hostile crap to people, mostly men, I also paint.

"The numerous conflicting duties of a whole women... have made every private creative minute a source of guilt." Yeah! If a man creates, if he writes or paints or sculpts and if he's serious about it, then he is usually considered to be "an artist." If he's unable to make a living by practicing his art, then this is taken as further verification of his status as a "true artist." If a woman creates, if she writes or paints or sculpts and if she's serious about it, she's almost never considered to be "an artist." She has "a hobby." If she's married, then this hobby is condescendingly tolerated. "It's nice that you have something to keep you busy," or "It's good to keep your mind occupied with an outside interest." If she is unmarried and cannot make her living by practicing her art, then she is considered to be a welfare chiseler, an immoral bitch, irresponsible, and lazy. phoeey. to hell with them. I don't give a damn what they think anyway, but I wish they'd stop thinking it.

I do think that creative men are faced in our society by many of the same problems and barriers facing creative women. But the difference is that society in general and the individuals involved, are aware of these societally imposed restrictions and constraints so far as they apply to men, whereas this awareness so far as limitations/barriers applied to women is often lacking and the real problems are most often perceived, even by the women themselves, as personal/psychological ones rather than social/political ones. The private attempt to cope with a social/political problem as if it were a personal/psychological one is enormously energy-draining; it can exhaust one emotionally, intellectually, psychologically, and spiritually. An emotionally, intellectually, psychologically, and spiritually exhausted person can't be a very good artist. Maybe that's why there are few good women artists.

Some really good books on the subject of art/people (let's be flighty and include women in here as people) are: *The Dehumanization of Art* by Ortega y Gasset; *The Necessity of Art: A Marxist Approach*, by Ernst Fischer; and Otto Rank's things on Art & Artists, especially "The artist's fight with Art."

power to the left out people  
(Pallas power),  
phyllis lanham  
saratoga, california

## These are a few samples of Phyllis' "miscellaneous stuff."

For years I thought of black people in our society: Why do they stay behind those bars that whites have built around them? Why do they tolerate it? Why don't they fight back and kill if necessary to preserve their humanity? I didn't become aware until the last couple of years that, as a woman, I had had bars constructed for me too. A prison with gold bars is just as confining as any other. I used to think that white men were victims of the system that has us all enslaved—that we were all victims, victim and victimizer equally, all trapped within the maze. But that's not true. Some of us have a wider range of choices than others, and white males have the widest range of all—they have the most alternatives to choose from. And the choices they make indicate that most are not so much victims as willing accomplices in the perpetuation of this system.

When men attempt to deny the political reality of problems by labelling them personal or psychological, when those in a position to do so—i.e., doctors, psychiatrists, politicians, lawyers—do not attempt to make injustices relevant to society, in whatever spectrum of society their profession qualifies them to exert their influence—when they mouth their concern for social justice and their abhorrence of the system at the same time that they embrace politics as the art of the possible and define possible in terms of the past—then they are more victimizers than victims. They are being phony and they are being cowardly. No amount of conscience—alleviating charging into the arena of blatant psychedelic-glowing injustice on a noble white steed is going to change the phoniness or hide the cowardice.

Have you heard of the law of *connunctio oppositorum*? It's a sort of philosophical assertion of the *sine qua non* quality of life's apparent contradictions and is, like a lot of other laws, irrelevant. It states: All things for their being or continuance require their opposites—i.e., no joy without sorrow, no good without evil, no tranquility without turmoil and—who knows? maybe no feminine bitchiness without masculine cowardice. Perhaps.

Things I do not like: marriages  
responsibilities  
doing somebody else's thing  
lines of demarcation  
compulsions (neurotic and otherwise)

Orientations I am allergic to because of succumbing-susceptibility:  
order (anyone else's)  
security (emotional and other)  
never-rock-the-boatness  
status quo obsequiousness  
irresponsibility  
emotional hedonism i.e., chronic  
absence of pain is the highest of all highs.

"I know a woman who decided to let the hair grow on her legs and it turned out her's were hairier than her husbands."

"what did she do then?"

"I don't know, they got a divorce."

## Dialogue:

F: Will you please stop pulling the Noosphere, and get your molecule out of my ribs!

R: What molecule? That's just my little finger.

F: I know an insult when I feel one poking me in the ribs. What do you think I am, an ass?

R: Well...ah...Mmmmmmyeah

F: Sex fiend! Take that!

R: (stiff-upper-lippery) Thanks, I needed that.

Much later:

R: Will you marry me?

F: (accusingly) You want to destroy our relationship!

R: What relationship?

F: Go to hell you fucked-up bastard you need a psychiatrist you are all putrid and yellow a bit brown around the edges too and no one in his right mind likes brown and yellow except a very earthy person which you certainly aren't. If you see everything as an accusation then you need to make some sort of financial arrangement with a shrink *toute de suite*: discuss canyon-peak, left-right, margin-freestyle, aloneness-togetherness, scRuthing-repression, indulgence-asceticism, etcetetcetc., and furthermore, be sure to ask him if letting a lot of hostile farts is normal.

R: It's normal for a masochist.

F: Masochist?? You call stinking up the whole house when you're going to leave *masochistic*?

R: I do if it's stinking up the whole house of a pyromaniac with flammable gasses.

F: Oh go to hell. The trouble is we need a sadist in this scene—two masochists just don't make it together.

R: Maybe we should put an ad in the Barb...!

## from rgw

speaking of tools, it's about time women started using their bodies as tools instead of excuses and liabilities. speaking of access to tools, read Kit Leder's words and remember that tools aren't so complicated that intelligence can't figure out how to work them. in my own experience struggling in woodshops and metalshops shaping my forms out of tree trunks and various joints, i have found that using leverage often makes the impossible possible. on the subject of motherhood, let it be known that being a mother has nothing to do with being a fulfilled female. on the idea of sex and tools, it is time women stopped relying on men for their sexual definition.

—robin gay wakeland

We would like to know/hear ideas about: women's communes, female pornography, the earth mother schuck, women's prisons.

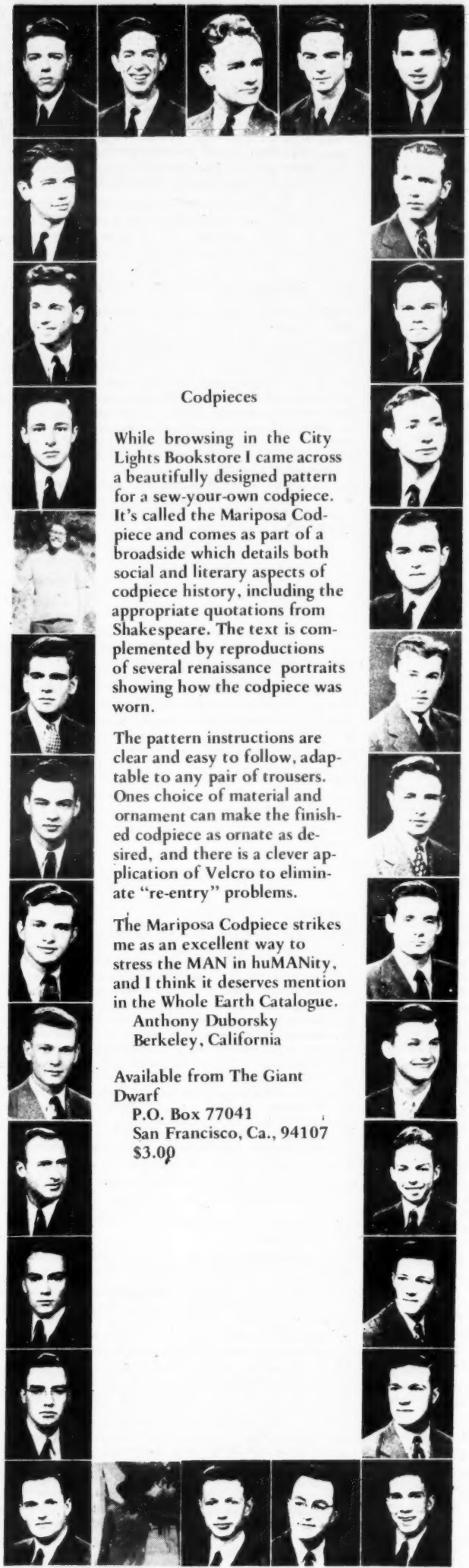

### Codpieces

While browsing in the City Lights Bookstore I came across a beautifully designed pattern for a sew-your-own codpiece. It's called the Mariposa Codpiece and comes as part of a broadside which details both social and literary aspects of codpiece history, including the appropriate quotations from Shakespeare. The text is complemented by reproductions of several renaissance portraits showing how the codpiece was worn.

The pattern instructions are clear and easy to follow, adaptable to any pair of trousers. One's choice of material and ornament can make the finished codpiece as ornate as desired, and there is a clever application of Velcro to eliminate "re-entry" problems.

The Mariposa Codpiece strikes me as an excellent way to stress the MAN in huMANity, and I think it deserves mention in the Whole Earth Catalogue.

Anthony Duborsky  
Berkeley, California

Available from The Giant Dwarf

P.O. Box 77041  
San Francisco, Ca., 94107  
\$3.00

# Codpieces & Milk Cups

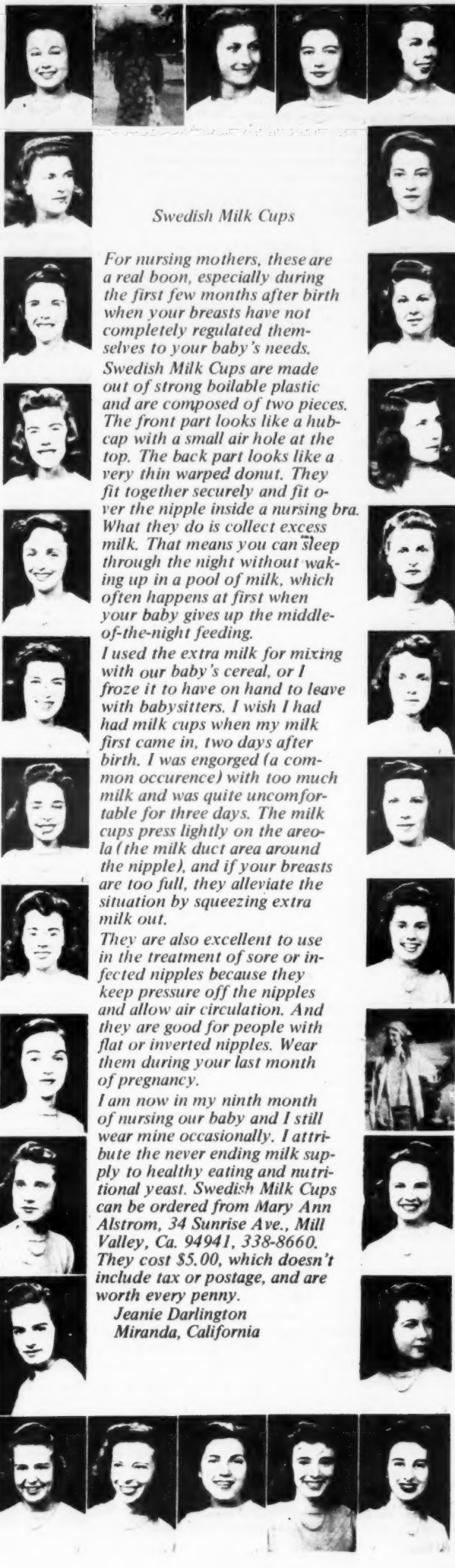

### Swedish Milk Cups

For nursing mothers, these are a real boon, especially during the first few months after birth when your breasts have not completely regulated themselves to your baby's needs.

Swedish Milk Cups are made out of strong boilable plastic and are composed of two pieces. The front part looks like a hub-cap with a small air hole at the top. The back part looks like a very thin warped donut. They fit together securely and fit over the nipple inside a nursing bra. What they do is collect excess milk. That means you can sleep through the night without waking up in a pool of milk, which often happens at first when your baby gives up the middle-of-the-night feeding.

I used the extra milk for mixing with our baby's cereal, or I froze it to have on hand to leave with babysitters. I wish I had had milk cups when my milk first came in, two days after birth. I was engorged (a common occurrence) with too much milk and was quite uncomfortable for three days. The milk cups press lightly on the areola (the milk duct area around the nipple), and if your breasts are too full, they alleviate the situation by squeezing extra milk out.

They are also excellent to use in the treatment of sore or infected nipples because they keep pressure off the nipples and allow air circulation. And they are good for people with flat or inverted nipples. Wear them during your last month of pregnancy.

I am now in my ninth month of nursing our baby and I still wear mine occasionally. I attribute the never ending milk supply to healthy eating and nutritional yeast. Swedish Milk Cups can be ordered from Mary Ann Alstrom, 34 Sunrise Ave., Mill Valley, Ca. 94941, 338-8660. They cost \$5.00, which doesn't include tax or postage, and are worth every penny.

Jeanie Darlington  
Miranda, California

## IN THE BUSH

Dear Mr. J.D. Smith

Mr. J.D. Smith if you go in the bush in the summer time you might need mosquito dope. You need guns, food, blankets, tea, bread and etc. In the summer if you want to go in the bush you need a boat to travel in water. If your going to rat river there are some houses that you can sleep in over night. There are some houses in Buffalo river also. There is lots of wildlife in the summer. When Indians go in the bush They make bannock and maybe someone can make you bannock for a dollar or 2. Maybe you can make some yourself its simple. Add flour, baking powder, water, melted lard and mix with 1/2 cup of sugar and cook. take heavy food not hotdogs or light stuff you might want to bring cookies and candy bars for a snack. You can build your own house in the bush. You can set your own traps or snares if you like.

Sincerely yours,  
James Larorque

## WHEN YOUR IN THE BUSH

Morris Beaulieu

When you go in the bush in summertime, there's lots of mosquitos in the bush you need some supplies you need axe, saw, shovel, guns like 22, 303, 30-30, and shotguns, you need cups, pots and pans, plates forks, spoons, knives with pails you could pick some berries like gooseberries, strawberries, raspberries, Saskatoon berries, mooseberries, and cranberries, you could boil it with flour and sugar you need mosquito dope, and food like, baking powder, flour, sugar, salt, bacon, butter lard, tea and coffee, with a 22 you could kill chickens, weasels, minks, and lots of things with 30-30 you could kill moose, lynx, wolves, caribou and other things with a 303, you could kill Buffalo, Bear, and lots of things you have lots of fun in the bush.



Dear Mister J.D. Smith

In the bush up here it's pretty good. The weather is good in the bush in winter but if it's in the open its cold sometimes very cold. In summer the weathers warm in the bush but there's lot of mosquitos The main food in the bush is fish meat bannock tea sugar salt berries rabbits The equipment you need is a gun and ammunitions axe a knife you need a gun to protect you from wild animal you can use it to shoot animals to eat like rabbits moose or chickens. a axe is useful, too for cutting wood for you fire The main use a knife is for skinning or carving. Went your'e staying in the bush you should or its more wise to put up your tent close to water not to close there might be a storm.

rabbit



June 18th/1970 Fort Resolution

Dear J.D. Smith,

In summer or winter if you are going in the brush you need a lot of stuff. The grub you might need are sugar, flour, salt, tea and baking powder, cups, plates, knives, forks and spoons and some other things likes tools shovels chisels axes and you might have to use a kicker. Mosquito dope is useful too. It is good to put a tent up high and close in water I like it in the Bush better because the water is clear.

Yours, Sincerely  
Tom Roger Beaulieu

# Summer in Fort Resolution

Dear j.d.;

Thanks for the letter. Glad that you wrote away to the Co-ops for their goodies. Some others which I don't think I mentioned—Coppermine (Eskimo), Fort Providence & Rae (Indian). I don't know whether these places have any info. on what they produce but I imagine they do.

I've been digging around for some stuff for you. Unfortunately we're a bit pushed for time at the moment as we're heading back to the homeland—New Zealand—via Britain & Europe—so what with packing our stuff up and getting that off and trying to make the odd arrangement for travel we've been "flat stick."

Most of the kids from my class have been in the bush so I showed them your note and they wrote down some of the things you'd find useful. They'd also written some of the stories on summer in this part of the world so I've thrown these in too. Hope you find them interesting.

As far as getting someone (native) up here to do something for the catalog goes: there aren't too many who still get a living from the bush—there are about 3/4 trappers who do pretty well, but other than this it's welfare with a bit of hunting and trapping to supplement this. Also there aren't too many who write. Maybe the best bet in this line would be to write the Game Dept. in Yellowknife and they may be able to help. Another possibility would be to come up here towards the end of summer (the road goes as far as Resolution) and see if you could go out on a trapline. Again the Game Dept. would probably help here. (Good road to Rae too—biggest Indian village in north.)

No newspaper here. Town is small (600 approx.) and is classified as a "depressed" area by the white man—mainly because of all the people on welfare. It's an interesting place. Over the whole north there seems to hang an aura of colonialism which could get worse now that the bureaucrats are running things from Yellowknife. After being here a year we haven't come away with a good impression of what the white man (i.e. Church, Hudson's Bay) has done for the natives. Most efforts seem to have demeaned the people and here anyway, there isn't too much of a dialogue going between white & native people. Latest effort is the N.W.T. Centennial—celebrating the sale by the Hudson's Bay Co. of the Native land to the govt. of Canada. This is a Metis settlement. Nature in the north is beautiful. The seasons changing—the vegetation, the landscape and the wildlife with it; the long days of summer, the long nights snow, ice and cold of winter; the seasonal activities of the people—getting wood; spring hunt; trapping; dog teams; ice fishing; picnics; boating—you can really groove on the whole scene. The contradictions of the beauty are all the white man's—time, frustration, bureaucracy, "I'm right—you're wrong," that sort of stuff gets to you after a while.

The oil companies are into their bit up here too—although I hope (and am sure/hopeful) that there won't be the wholesale sellout to big business as there seemed to be in Alaska; I'd like to hear everyone say—stick your oil, let's turn the whole N.W.T. into a national park where people can come and join with nature and groove on the beauty and vastness of it all. At least people both in the North and outside are concerned and are working for restriction on oil and mining interests.

A couple of worthwhile books you might like to read on recommend on the north are—*People of the Light and Dark* and *The Unbelievable Land*—both available from the Queen's Printer, Ottawa, Ontario, Canada and both pretty good resource works. They're about \$2.50 each I think.

Indian Land Claims in the N.W.T.—I don't know about this but try dropping a line to the Dept. of Indian Affairs and Northern Development in Ottawa. I do know the Indians have hunting and fishing rights on all land and that the white man is restricted in this to some degree—e.g. one moose per season.

As far as setting down somewhere goes I've written to the Territorial Govt. and told them to forward you any information they can.

Hope that this isn't too garbled and that you get some satisfactory info from the Govt. If you want to know any other things—like names of people who could help if someone wants to have bash at it up here—drop me a line and I might be able to help—at P.O. Box 282. Pukekohe, New Zealand

Cheerio & Peace,  
Peter Hansen

## SUMMER IN FORT RESOLUTION Tom Beaulieu

I know when summer is coming because the snow melts and it stops snowing. We don't use dogs and we can't haul water. Rabbits turn brown and weasels turn brown and the season for trapping is closed. They clean up yards and kids take their bikes out. We played physed outside now. Its warms up and the days get longer The grass and the trees get green, gardens are planted. We can ride a canoe, Insects come back. We could go berry picking. We could go swimming and barges come in. We could go fishing and frogs come in too. Bears wake up and ptarmigans go away. I like summer and winter the same because in summer I go swimming and in winter I very hockey. The programs in T.V. are better in winter.

## SUMMER IN FORT RESOLUTION Morris Beaulieu

In summer you could go for a Picnic at Polette Creek, Buffalo River, Mission Island. Across the Portage, Sight, and by boat you could go to Round Island. And you could go swimming, all the snow and ice melts all the fish spawn in Polette Creek. You could fish in the lake with nets at Polette Creek you fish with a hook and a 22, or a rod. Bears wake up, Rabbits and weasels turn brown, the grass and the leaves turn green. The gardens are planted. People don't drive dogs anymore. People clean up their yard, People Play baseball barge comes in, some people water ski. People go for spring hunt to hunt for rats and Beaver. Beavers build dams in the summer so they can make a beaver lodge Kids take out their bikes to ride around. All the ducks, swans cranes and birds come back. Ptarmigans turn brown. They pick berries to eat. They have Sports on July 1st there's lots of Sports. When the ice melts you can drive a speed boat a canoe or a scuff. I like it in summer better because its warmer and lots of things to do.

When the snow melts, ice melts I know summer coming. I clean around my house. I burn grass. I rake it all up. Then they haul it away to the dump. The men clean the ditches too. The rabbits turn brown so do the weasels. The kids take their bikes out, we don't play inside no more we play outside now we could go to Polette Creet and shoot fish instead of buying food or else you could bring food. The days get longer and the nights get shorter. We make camp in the bush and the people can't see it cause the grass and trees are green. The leaves hide our camp. In the summer we go to pick berries. We can drive boats and make rafts. We could go swimming we could go canoe riding, bike riding sports.  
(unsigned)

## SUMMER IN FORT RESOLUTION Cecile Lafferty

When the weather gets warm people clean up their yards and kids get their bikes out and people go for picnics at Polette Creek or at Buffalo River. School is over at the end of June so we go for our holidays, then kids go swimming and barges come in. We have fishing and we have sports. When it is time for dinner or supper people might eat outside or inside, and when it is warm the grass and trees turn green and the bears wake up from their sleep or the moose comes. The beavers make dams and rats come out the frogs come out and they make lots of noise. The days get longer and mosquitoes, flies and insects come out. People pick berries, and they plant gardens. When we have physed we have it outside cause it is warm and its better that way. The rabbits shed fur and the rabbits and weasels turn brown, the birds comes and ducks, geese and seagulls come and find food for themselves. People go water skiing and some go for canoe rides then it is winter and people have to get ready cause they know it is going to be real cold.

## SUMMER IN FORT RESOLUTION May 26th

I like summer in Fort Resolution because all the birds sing and people are going hunting. All the snow melts and the ice melts. All the rabbits turn brown and the weasels turn brown, also. All the dogs shed fur and people spring cleanup, beavers build dams and kids get their bikes out. We never play physed in school most of the time we play outside. You don't see any more hockey on T.V., The weather warms up. Days get longer, and lots of geese and ducks come back, Moose and a lot of wildlife. We don't use dogs anymore for hauling water and The grass turns green and the leaves turn green also. lots of people plant gardens the schoolkids look forward for summer holidays. Bears come out from their long sleep. People go to polette Creek for fish and some people go to little buffalo They also go on picnics across the portage, and Mission Island. Kids go for a ride to the site, people also go rat hunting. I like swimming. Frogs Croak at night people go berry picking. Mosquitoes, flies, & insects are out we have summer sports. Canoe rides, fishing. The barge comes in with things. I like summer and winter because in summer you can go swimming and in winter you can play hockey—because thats my favorite sport in winter.

by James Larorque

30 July 70

Steve,

OK. Japan is wonderful. Very creepy sometimes—they want nuclear weapons—everybody WORKS constantly—bushido is eastern machismo—everybody obeys. They've got 1980-2020 control of the planet just about sewed up, and I say, They're welcome to it. We lived in an old-style house in Kyoto with people who know how, where I could glimpse some of the craft-of-living they're into. Exquisite. Living and structure indistinguishable. I felt Americans were brutal clods. (Until visiting an architect in Hawaii—house a lot like a barn, with big blowing landscape, cloudscape, bambooscape—felt fine. In barns reposes any American genius of building—minus architects, naturally.) The most revealing event in Japan was a visit to a skin theater near the Zen Temple of Daitokoji. The girls (every other one is a bleached blond) prance to top-40 tunes and then come and spread their legs 10" from your face and talk sassy. Everybody peers in—young students are most of the audience. One girl was terrific, also gutsy actress. The last one had no vagina (cropped boy?): very cruel Theater. The whole event was like an x-ray of Japanese manners. Staying with Richard and Virginia Baker, besides enjoyable, was a course in operational Zen Buddhism. Lovely if I could ever find the hand in me that matches the Zen handle: it's an opener alright.

Expo is just another tiring Expo. The only thrill I've ever gotten at any expo was Labyrinth at Montreal. Japanese have close-packing down cold. They do more with less space than anybody—more rice per acre, more comfortable people per house, more sales per market, name it. Awesome. They just take the trouble to fiddle endlessly with, say, one tomato plant until it feeds five families. They even have more lethal pollution—some street corners in Tokyo are unbelievable. All futurists should do time in Japan.

Hong Kong was my first visit to being white in a British colony. Inexpensive plush. A sensational breakfast served by five-six Chinese who are putting in 12-16 hour days. I didn't investigate the economy at all, but it looked labor exploitive. Lois loved it, me too—it was all the niceness that Las Vegas fails miserably at, a genuine aristocratic niche. I dislike its existence, but I'll bet there always is some in the world. Hong Kong makes me think that.

The harbor is sure enough gorgeous mountain—surrounded crowded. Exciting on a boat—every craft in the world going every which way. The freighters moor out in the middle and get unloaded by funky big motor-junks with the whole family living and working on board. Some noble sights of girl-at-helm up against traffic, currents and weather. Tropical rain and sun keep flashing by, blowing handsome toward CHINA hulking just over there. Energy edge. Hong Kong.

Australia was a downer for us—not all Australia's fault. We were tired. It was winter. The guy we visited in Sydney was heavy political French hate-America. He worked us over, and Australia over; no rest for the wicked.

Australia—this is 5-day expertise—is tight-ass politically and culturally. Education is distrusted. Lottery and football clubs occupy a lot of consciousness. Immigration is sought energetically, and selectively (non-white need not apply). Natural resource land-fuck is in progress, largely at the hands of Japanese and Texans; Australians still lack capital to do their own industrial added-value work. Immense areas of land—if you want to buy 100 square miles, Australia's your meat.

Dave and Jean Evans are in Adelaide (on the south east coast), which is described by some Australians as Cemetery-with-lights. A planned city. Felt like early 50's; Minneapolis maybe. Looked like California land, eucalyptus trees and all.

Dave's job is helping guide some new changes and money for the aborigines, with one eye on US mistakes with the Indians. The Australian aborigine policy looks remarkably human to us. Abs culturally are in far worse shape than American Indians—even more whipped by alcohol, job regimen, etc. Some tribes are remote and intact, but fragile. We visited two heroes—one an older guy running an aboriginal art program that infused pride and skill to city abs. The other a young stud with a beautiful aborigine wife, superintendent of a small reserve of detribalized abs on the coast—beautiful place, incredible problems—but a sweet visit for us. He could—the guy—step into any scene we know and get comfortably right to work.

Stewart

## Catalán Earth

We lived in a coast town 25 kilometers from Barcelona along a fast and frequent electric train route and the most ambitious freeway in Spain. But it was not a suburb. You can consider suburbanization as conversion of the traditional summer house into a night and weekend house. No townspeople worked in Barcelona to my knowledge. Most of them were born there or in one of the closely packed next towns. Babysitting was unknown, partly because people seldom went out, but also because they all had cousins in walking distance. They are prosperous by Spanish standards. Many, for example, have washing machines (although the village still has a communal spring where old ladies come to wash and gossip.) But they speak of Barcelona as strange and unknown. No one can tell you how to find streets in the city 16 miles away. Technology without transcendence.

Besides summer people the main work is truck gardening. Tiny stores make it in Catalonia. Two dry goods stores, four groceries, two beef markets, two fish markets, one pork and grocery market, one stationary, one hardware store, one bakery in a town of 900. The owner lives above and behind each, with a sales space not bigger than a California ranch style living room. They own washing machines too.

The Cataláns are proverbially "peseterías", that is devoted to coin. But from the same root comes the word for weight; they are heavy people. Our yard faced one of those truck farms. It was three or four acres. We would see the jardinero working from daylight till after sunset seven days a week. He is a fat man, with a floppy hat and well wrapped in old clothes with a spray can on his back, or a hoe, or opening irrigation channels, or plowing with either a burro or a roto tiller. The earth is sandy and does not look fertile, but they haul tons and tons of green stuff out of it.

We planned to stay from January until June so I forsook gardening. I mean, some of you don't use insecticide but when I found a snail on the fire wood, I carried it outside and set it on a soft weed. Total truce with bugs and plants. A surprising and lovely array of wild flowers was our reward. I sometimes wondered how the jardinero felt about that. I doubt if he liked it.

Organic fertilizer, yes. Once our street was blocked by a pile of manure that fed slowly into the garden. The jardinero lived in a big stone house on the corner of the land. It had a big stone out building and, like all Catalán farms, a large cistern. Like all those cisterns, his had water lilies and overgrown goldfish. Around the house a chicken yard. The garden raised carnations (picked for the Paris market when each bud first cracked color so the field was never in bloom), onions, the fava bean ubiquitous in Catalonia, the very tasty Spanish green beans, peas, cabbage, lettuce in season, potatoes; the climate is very like San Francisco except no fog. He controlled weeds with heavy mulching but also with herbicides. Use of insecticides there is heavy and uncontrolled. I see him now, leaning on his weight in one part of the garden; working in other parts are his wife, a sentimental woman with a violent temper, and his only child, a son, just back from the army, with hair a little long. The wife sells the produce every morning in the next town. They are said to be rich.

They are not talking politics. The thing about politics in Spain is, it is unobtrusive. Everyone tells you how the Guardia Civil used to depress the atmosphere by standing on street corners everywhere with their rifles. Now you seldom see them, you see fewer police than in America. The theater where Jerry Rubin, or George Wallace, or Nixon or McCarthy strut their parts stands empty in Spain. The newspapers report foreign news briefly but neutrally and well. Spanish news is appointment of subcabinet ministers, local mayors, opening factories, freeways. Pseudo news. Likewise the drug scene. I know people who have scored in Barcelona, but I have no idea what the scene is because people don't talk and I have never seen the Spanish word for grass ("grifa") in print. Every town in Spain has a Falange party headquarters, but they mostly lack new paint and new blood. They are a sinecure for civil war veterans. Doubly so in Catalonia. I saw a rock concert going on in the Falange party headquarters in San Juan de Vilasar.



Protest of a sort is even allowed. Of just the sort Reagan would allow. The mayor of our little town (an official appointed by the provincial governor, who is appointed by Franco) banned parking on the street where most of the shops stand. The shop-owners had a meeting and protested, quietly. The parking was changed.

But two years ago there was a demonstration at the university in Barcelona against the course structure and other university matters. The president of the university was thrown out the window of his office, and, very embarrassing to the government, priests demonstrated on the side of the students. It even got into the newspapers a little. Franco did not fuck around. He closed the university. It's still closed. Pow.

Pow. Power. Authority. Nobody knows what will happen when Franco dies, which may be anytime soon. His designated successor as head of state, Don Carlos, may be the pastiest noodle in European history. A middle aged youth who makes Eisenhower seem forceful and quick minded. No one can imagine him actually ruling for more than an hour. A gradual drift toward liberal democracy whisper the semi secret liberals in Madrid with the same kind of sick sweet absolutely baseless insinuation of prescience that cold war liberals lick off one another in the pentagon. A new civil war and/or an independent state of Catalonia are conceivable. We got delicious crusty bread delivered daily by motorcycle for 7 cents a loaf. When I went to tell the breadman that we were going to Madrid, Toledo, Granada and some other cities in Andalusia so he would not deliver while we were gone, he said, "Oh, you're going to Spain."

As here, people on the street are young. I'll bet the average age is lower than here. The predictors don't take into account what would happen if these young people got behind some idea or other of politics. Now they are behind none. There is a hip population in the cities. Not so many long hairs as California, but they are there. Their values and fantasies and personal life is about the same as long hairs here or in France or anywhere; the more you get toward pop culture the more international everything is. They do not seem to be much interested in issues of the civil war although a certain number are marxists. It seems to me inevitable that they will some time come to consciousness and start rocking the boat.

Dirk van Nouhuys

(Note: Dirk spent several months in Spain this year).

## Irish Folk Ways

Irish Folk Ways  
by E. Estyn Evans,  
1967: 342pp.  
20s. published by  
Routledge & Kegan Paul Ltd.,  
Broadway House,  
69-74 Carter Lane,  
London E.C.4.

This should be subtitled 'How to ignore the advertisements of the Agricultural Industry and live.' Proof, if proof is needed, that you don't need much metal and more money to get by. Concentrating largely on the least fertile parts of Ireland, E. E. Evans describes in detail the tools, techniques and building which, for 5,000 years or more in some cases, people have been using to provide shelter, food, warmth and not a few treats in competition with the rougher edge of nature. It should be of inspirational use at the very least to anyone living independent of too much technology. Well illustrated both in line and half tone, the book describes, among many other things, building and thatching methods, hand cultivation techniques, carts, boats, rope making, fencing and walling, furniture making and fishing. With the minimum of equipment the book would enable you to produce duplicates and there are copious footnotes if you want to follow up any specifics.

from:  
Whole Earth Catalogue,  
British edition  
305 Portobello Road  
London W. 10  
England

Mud walls were built up with a fork in layers twelve to eighteen inches deep of a mixture of damp clay and cut rushes which had been left to go sour. A stone foundation layer sunk into the ground was usually built first, and sometimes the gable ends, especially if a chimney flue was to be included, were built entirely of stone. They were afterwards trimmed with a sharp spade to a thickness which averages about twenty inches but may be as much as thirty.

Both scythe and sickle are personal possessions and their luck is personal; they are loaned with reluctance. When a sickle is borrowed it should not be passed from hand to hand but thrown on the ground and then picked up. This belief, which applies to all pointed objects, may be explained by the danger of handling a sharp tool. For bad luck is often related to bad practice.

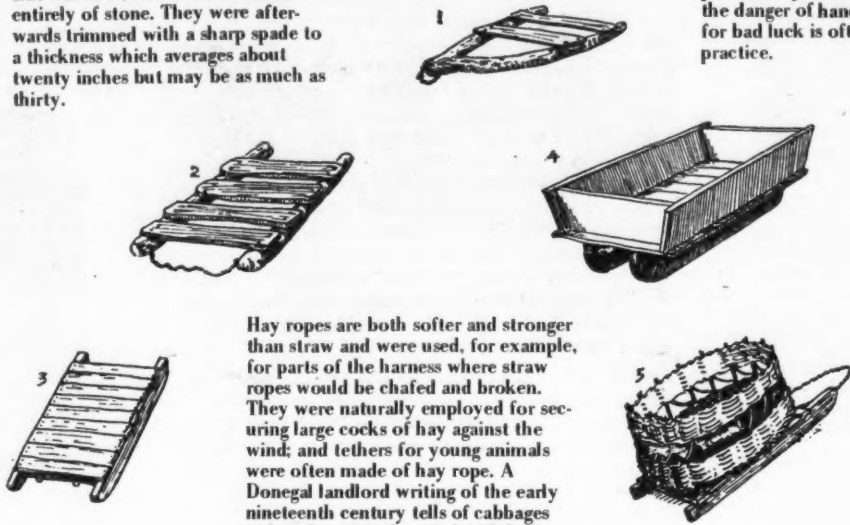

Hay ropes are both softer and stronger than straw and were used, for example, for parts of the harness where straw ropes would be chafed and broken. They were naturally employed for securing large cocks of hay against the wind, and tethers for young animals were often made of hay rope. A Donegal landlord writing of the early nineteenth century tells of cabbages tethered against the wind with hay ropes.

In some parts of the country, especially along the east coast, a form of sled fitted with a box body is kept for the transport of manure, though it is also used for carrying earth on steep slopes where the soil is washed away and is tediously replaced. In this form of sled the runners are deep and set close together so that the load can be tipped out over the side. The sled or slipe is transport-agent of remarkable versatility, ideally suited for small-scale operations involving heavy loads, and it persists because for some purposes no more convenient method of transport can be devised.

FIG. 58. Slipes. (1) Forked slipe, Co. Antrim. (2, 3) Stone slipes, Co. Down. (4) Manure slipe, Co. Down. (5) Turf slipe, Co. Antrim.

## Announcing: Australian WEC

We own a bookshop in Melbourne stocking mainly books from America—that is—the books from America (and some local & British) that have meaning to today's consciousness and a positive vision for the future. We've been in operation about 1 year and the response to the type of books we stock has been wonderful. People "Down Under" are starved for Real information . . . because of the big business setup of most bookstores here . . . only certain British books make the stands. We are trying to do something about, are having great success with the public but much opposition from the trade.

We have been selling W.E.C. for about four months (the only outlet in Aust. to my knowledge) and the response has been nothing short of incredible . . . we keep ordering larger quantities and selling out even before they arrive. The only complaint that W.E.C. buyers have is that there isn't any local information. We have decided to remedy that with an Australian version of W.E.C. We plan an initial printing of 4000 to be distributed to all states by a large distributing company. Our version will contain not only a catalog section but also articles on ecology, communes, travel, etc. etc., also, there will be a section devoted to what could be called — New Age Creative Output — . . . this will include poetry, plays, fiction, film scripts, photos, drawings etc. Because we believe the three sections relate to one another, help each other, we hope that our readers will discover new areas which they were not aware of.

The Source  
(Books from America)  
121 Collins St., Melbourne,  
Vic. 3000, Australia

## Tree Seeds?

I am trying to start a small collection of trees in southern Ontario, Canada and would appreciate the help of your readers in getting sources for seeds of trees from places anywhere in the world but especially the United States and Europe.

I am especially interested in all non-fruit trees—not shrubs—that are capable of being grown in up to latitude 50 in the northern hemisphere around the great lakes.

Any information your readers could give me by writing me personally or by inclusion in an edition of the magazine would be most welcome as well as available for the use of anyone desiring to start a similar collection.

Fred Roth  
2786 Dublin St.  
Halifax, Nova Scotia, Canada

## WORLD NOTES

### Hand Husker?

On the island of Formentera, among other things, are grown Oats and Barley. Since the local people only raise these crops for chicken-feed, there isn't available any means of husking the grains and using them as a grain food, like rice or wheat. So far, all we've been able to do is mill the whole thing, then sift out the husks and use the flour. So—

Can you recommend a hand machine for husking oats & barley? Either in the U.S. or England? Do you know how this husking is accomplished in the food industry in general?

It would really be very nice if you could help us with this.

Yours Sincerely,  
R. Altman  
San Francisco  
Formentera, Balearas,  
Spain.

### Memo From Paradise

A couple of years ago I discovered this little country. It's not really a country, yet, it's a colony. It's a tropical place; got a lot of rivers, mountains, coconut trees, parrots, islands, monkeys, cashew wine, stone crab, jaguars, sailing boats, fish, rum, reefs and some other things. All sorts of people live here. Some are tan and are black and some are freckled and some are white. If you speak a little Spanish, English, Maya, Carib or Creole you will be understood here.

Awhile back I brought my wife and kids here and bought a piece of an island and built a house. The island has a village, about 400 people, they fish, sail around, while all the kids swim and splash around and laugh a lot. What I'm going to do is build a couple of cabins on the beach and have some boats and let people come out here and go diving, swimming, fishing, sailing or whatever. I think they will want to go home and sell all their stuff and come back and do something.

We could sure use some teachers or farmers or marine biologist types, or some people who could figure out how to make something useful or exportable from whatever natural resources we have here. Actually, we don't like to admit it, but, we are not too sure just what we do have. There just hasn't been enough exploration of a scientific nature around here.

Anyhow, if you're not involved in some big thing right now, gas up the car and come on down. The place is called British Honduras. It's just south of Quintana Roo and east of Guatemala on the Caribbean coast.

If you're not that impulsive and want more facts and information on the place, let me know and I'll do what I can.

Frank Bazzell  
Caye Caulker  
British Honduras

### Peace Corps Defended

In response to the catchy ad to join the Peace Corps (July 1970 catalog, page 44) . . . No wonder middle America's taxpayers protest paying taxes to support the Peace Corps: "a local travel agency." Mobius Polymers Unltd.'s blatant confession of how to exploit for greater fun and free amusement is just the sort of food that feeds a hostile conservative's low opinion of governmental aid agencies.

The Peace Corps as described in the Mobius letter sounds too good to be true. . . to someone who wants to take all that he can while giving nothing in return, who patronizingly talks of "enjoying better aspects of natives . . ." and whose materialistic uninvolved approach provides him with a backdrop of total non-experience whether he imposes non-self on a bush town in Appalachia, or in Tunisia. This attitude makes the colonialists sound like Super Altruists.

Countries in which Peace Corps sends volunteers have more than their share of natural problems: so why laden them with with U.S. suburban guerrillas on a large ego trip?

Paix  
Julia C.S. Keefe  
Chapel Hill, North Carolina  
Veteran volunteer,  
Senegal, West Africa

### Summer Digs

The Council for British Archaeology, 10 Bolton Gardens, London, S.W. 5 publishes *Calendar of Excavations*, c. 50 cents per year monthly March through September. This bulletin lists archaeological digs (and field schools) planned or under way in Britain with details of salary, type of work, qualifications wanted, etc. With no previous experience a digger can often get paid 10 shillings per day by the Ministry of Works—enough for room and board. More, if you can camp. There's usually opportunity for weekends or weeks off work for hitching around. Digs generally run during the four summer months, and you can usually work all or part of the summer and thus live in England free—often in a sort of camping commune which lets you get to know people and places. With \$50 cash I flew a charter flight New York-London round-trip for \$210 and returned with some of my cash. Part of the plane fare investment was made up by the fact that I could buy a few "permanent" possessions there for about half what they would have cost here in the U.S. Thus the trip really cost about \$100 more than living in the U.S. without an income—but living here I would have had expenses (and no job). You can quickly find out all sorts of free places to crash, travel, eat, etc. once you have a "base" in Europe. But if you want to get paid, make arrangements in advance. You may be able to get "room" (or tent) free if you simply show up at a camping dig, but the Ministry of Works money has to be arranged for. At the least the *Calendar* may provide a travelogue of crash pads—probably in return for volunteer labor; it's better to get a little pay, though—and fairly easy. (Digs in America are generally much less interested in volunteers or employees—they have more field student-slaves available! University anthropology departments and various state archaeological societies and *American Antiquity* may be of some help, but paying jobs are few.)

John R. Cole  
Lincoln, Nebraska

# WORLD GAME

Hello,

I just picked up the July Catalog, saw Cary James' letter about the World Game, and felt moved to reply. I've written articles on the Game for the "Earth Times (R.I.P.)", and the "San Francisco Chronicle," and I'm currently working with the San Francisco Game.

"Wiring up the globe" is really a bad choice of words. It brings to my mind nightmare visions of the earth caught tight in the grip of a copper-aluminum wire girdle. Did Gene Youngblood use those words? I can't check right now because my copy of that Catalog is with a friend.

World Game does propose linking together world communication, transportation, and energy systems. A process is now extant whereby lasers can deliver electricity. Lasers and Telstar can already handle communications with unparalleled efficiency. Webs which utilize lasers and electro-magnetic waves could interconnect energy and communications without wiring up the planet. In fact, many of the wires that now mar our landscapes could be taken down and the metal resources used elsewhere.

One of the benefits of these webs is that existing power sources, which now operate at about 50 percent capacity, could be fully used, almost doubling our current power supply and doing away with much of the need for damming more rivers, burning more fossil fuels and so forth.

One is on very shaky ground making short reference to "Christian" thought. Is the reference to St. Paul's Christianity, or John Calvin's, or Martin Luther's? A very wide metaphysical chasm separates Billy Graham and Teilhard de Chardin.

World Game has a concept of a "bare maximum." It's not a Buckminster Fuller idea. It came out of the New York Studio School World Game seminar in summer 1969.

A "bare maximum" is the most of a resource that a human being will use under optimum conditions. World Game wants to make available to every human being, free of charge, a bare maximum of food, electrical energy, shelter, communication, education, health and medical care, transportation, and leisure. Free. Not that everyone would have to use it all. If you want to fast, no one forces you to eat a bare maximum of food.

World Game simply wants these resources available. Free. No more having to work to stay alone or prove self-worth. If that's not a change from Christian Calvinist ethics... face it, it's a change.

Is there an attempt at analogy in the reference to "an old Chinese parable?" the "gain of efficiency" the farmer refused may have kept a few people from starving.

Fuller, and the World Game, would like to automate the means of production. Several benefits would follow:

Because machines can do many, many jobs faster and better than humans—more efficiently—and do them on a 24 hour a day basis, industrial cities would actually shrink, returning surface land to nature.

There is a correlation between industrialization and birth rate: as the former increases, the latter declines eventually balancing the population. Evidence in support of this is found in the latest U.S. Census report, the July issue of "Scientific American," and the *Geography of Hunger*, by former chairman of the executive council of the United Nations Food and Agricultural Organization Josue de Castro. Efficient industrialization could curb the menacing population crisis.

Efficient automation would free the thousands now subjugated to assembly line production. And those thousands wouldn't have to commute back and forth each day in their pollution spewing automobiles.

World Game is suggesting that humans stand aside and let machines do what machines can do better than humans: produce basic goods, commodities and services. Humans: collect your bare maximums. Free. And what's to do with your time? Make love, get high, actualize innate capabilities, create, learn, enjoy... commune with nature.....

Om  
Hal Aigner  
628 Throckmorton  
Mill Valley, Ca. 94941



Your catalog (book? magazine?) has helped me locate where I'm at. Thought I might pass along some information in return:

Another good book on electronics: *Electronic Communication* by Robert Shrader, McGraw Hill. Quite readable, covers everything from the basics (electrons, atoms and such) to radio, TV, and microwaves, with a special section on amateur and naval radio. (1967 edition also covers transistors) Having lived with the book for two and half years, I'd be willing to write a review, if you so desire.

You list GE's SCR book, but for anyone who knows a little about electronics, their transistor manual (the thick one) is useful. It covers audio, radio and basic digital (computer) circuits, including circuits, diagrams. Wrote to Carbondale (Bucky and his group) requesting information on the WDSO Documents. Received a nice little pile of information not only on this (see enclosed photostate) but on the World Game Seminar and on the World Game Seminar and on Bucky in general.

Example: if you and at least three other friends can dig up \$15.00, you can set up a World Game Extension Study Group. (You get a procedures manual and inventory slides)

Peace,  
Richard Gould  
1583 Morris Rd.  
Kent, Ohio

## World Design Science Decade 1965-1975 Publications

Major publications from the World Design Science Decade 1965-1975 series, now available as follows:

### Inventory of World Resources

Human Trends and Needs  
—by R.B. Fuller and John McHale

### The Design Initiative

—by R.B. Fuller

### Comprehensive Thinking

—by R.B. Fuller

### The Ten Year Program

—by John McHale

### Comprehensive Design Strategy

—by R.B. Fuller

### The Ecological Context: Energy & Materials

—by John McHale

\$5 each

Except students, who may purchase single volumes at \$1.75 per copy or \$10.50 per set (6). Add \$1.50 for postage and handling in the United States; Airmail costs are \$12.00 for Europe and \$18.00 for Africa and Oceania.

Sea Mail costs \$3.00; however, shipment takes approximately six weeks.

\*\*Please specify which class of postage to be used\*\*

from:  
WORLD RESOURCES INVENTORY  
206 West College/Parrish Building  
P.O. Box 909 — First Floor  
Carbondale, Illinois, 62901  
U.S.A.

## Buddhist Economics

The Buddhist point of view takes the function of work to be at least threefold: to give a man a chance to utilize and develop his faculties; to enable him to overcome his ego-centredness by joining with other people in a common task; and to bring forth the goods and services needed for a becoming existence. Again, the consequences that flow from this view are endless. To organize work in such a manner that it becomes meaningless, boring, stultifying, or nerve-racking for the worker would be little short of criminal; it would indicate a greater concern with goods than with people, an evil lack of compassion and a soul-destroying degree of attachment to the most primitive side of this worldly existence. Equally, to strive for leisure as an alternative to work would be considered a complete misunderstanding of one of the basic truths of human existence, namely that work and leisure are complimentary parts of the same living process and cannot be separated without destroying the joy of work and the bliss of leisure.

From the Buddhist point of view, there are therefore two types of mechanization which must be clearly distinguished: one that enhances a man's skill and power and one that turns work of man over to a mechanical slave, leaving man in a position of having to serve the slave. How to tell the one from the other? The craftsman himself, says Ananda Coomaraswamy, a man equally competent to talk about the Modern West as the Ancient East, 'the craftsman himself can always, if allowed to, draw the delicate distinction between the machine and the tool. The carpet loom is a tool, a contrivance for holding warp threads at a stretch for the pile to be woven round them by the craftsman's fingers; but the power loom is a machine, and its significance as a destroyer of culture lies in the fact that it does the essentially human part of the work.' It is clear, therefore, that Buddhist economics must be very different from the economics of modern materialism, since the Buddhist sees the essence of civilization not in a multiplication of wants but in the purification of human character. Character, at the same time, is formed primarily by a man's work. And work, properly conducted in conditions of human dignity and freedom, blesses those who do it and equally their products. The Indian philosopher and economist J.C. Kumarappa sums the matter up as follows:

"If the nature of the work is properly appreciated and applied, it will stand in the same relation to the higher faculties as food is to the physical body. It nourishes and enlivens the higher man and urges him to produce the best he is capable of. It directs his freewill along the proper course and disciplines the animal in him into progressive channels. It furnishes an excellent background for man to display his scale of values and develop his personality."

If a man has no chance of obtaining work he is in a desperate position, not simply because he lacks an income but because he lacks this nourishing and enlivening factor of disciplined work which nothing can replace. A modern economist may engage in highly sophisticated calculations on whether full employment "pays" or whether it might be more "economic" to run an economy at less than full employment so as to ensure a greater mobility of labour, a better stability of wages, and so forth. His fundamental criterion of success is simply the total quantity of goods produced during a given period of time. "If the marginal urgency of goods is low," says Professor Galbraith in *The Affluent Society*, "then so is the urgency of employing the last man or the last million men in the labour force." And again: "If... we can afford some unemployment in the interest of stability—a proposition, incidentally, of impeccably conservative antecedents—then we can afford to give those who are unemployed the goods that enable them to sustain their accustomed standard of living."

From a Buddhist point of view, this is standing the truth on its head by considering goods as more important than people and consumption as more important than creative activity. It means shifting the emphasis from the worker to the product of work, that is, from the human to the sub-human, a surrender to the forces of evil.

While the materialist is mainly interested in goods, the Buddhist is mainly interested in liberation. But the Buddhism is "The Middle Way" and therefore in no way antagonistic to physical well-being. It is not wealth that stands in the way of liberation but the attachment to wealth; not the enjoyment of pleasurable things but the craving for them. The keynote of Buddhist economics, therefore, is simplicity and non-violence. From an economist's point of view, the marvel of the Buddhist way of life is the utter rationality of its pattern—amazingly small means leading to extraordinarily satisfactory results.

Sent in by John K. Green

Resurgence  
published 6 times yearly  
3s. single issues (U.S. 50 cents)  
£1 per year (U.S. \$3.00) post free

from:  
24 Abercorn Place, St. John's Wood,  
London, N.W.S., England



# A Chairmaker

by Michael

Basic to the understanding of a traditional art is a knowledge of the technical processes involved in creating the objects. Therefore, while many cultural and economic aspects of the chairmaking craft warrant analysis, it is necessary first to describe the way in which chairs are made. The description that follows is based on six weeks of observing and photographing at work Chester Cornett, a Kentucky chairmaker living in Perry County. Of course he is only one of many folk craftsmen in Appalachia who learned their craft from relatives and fellow artisans without recourse to written instruction or formal training. His methods and techniques are typical of this centuries-old tradition with the one exception that he does use a turning lathe. Cornett's case is also of interest because recent national publicity has resulted in processual modifications to meet increased demands for his product. This in turn suggests problems and solutions of a practical nature important to other traditional craftsmen.

With a few simple tools a mountain craftsman like Cornett can make a "settin' chair," dining chair, or rocker from the tree to the finished product; and "taken' it from the stump-it takes one week to make a settin' chair and a month to make a rocker." He uses an axe and coarse saw to fell the timber in the mountains, preferring to cut it in the fall of the year and on the "olden moon" when the wood is relatively dry and less subject to cracking during seasoning. He has no automobile or work animal so he must "pack in" the logs on his back (Figure 1).

The next step in making a chair is to quarter the log. The chairmaker drives an axe into the bolt to start a cut and then splits the log with a hickory maul and dogwood glut, a method used by many woodworkers because it preserves the natural strength of the wood by cleaving along the grain (Fig. 2). He then roughly shapes the planks into posts about four inches square by hacking many slight cuts in the plank and gently slicing them off so that the hatchet blade does not gouge into the wood. The slats are shaped in much the same way and two or more slats may be riven from a single board, like handmade shingles, using the edge of the hatchet as a froe. He prepares dowelling for rounds and pegs from smaller pieces of wood.

At his handmade drawing horse Cornett dresses the posts into octagon shaped legs with the drawing knife. (Fig. 3) and cuts the stile or flat face on the front surface of the back posts. The other pieces are also dressed. Then he marks off in pencil the places where holes will be drilled in the posts. Measurements are with the hands, not a ruler: the width of two hands with thumbs overlapping is twelve inches, the edge of his first to the quick of his extended thumb is six inches, and the width of one thumb is one inch.

Slats and posts are then cooked in a tub of water to make them pliable, twenty minutes in boiling water for the slats and an hour for posts. After the slats are steamed he "breaks" them (Fig. 4), inserts them into a slat



1



2



3

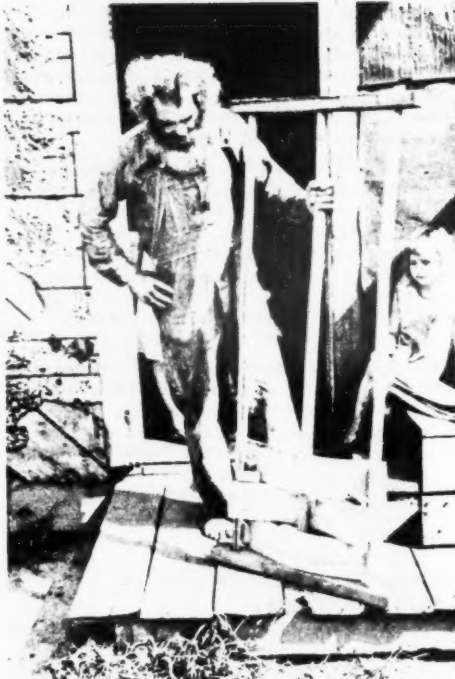

5



4



6

# Maker at Work

Michael Owen Jones

press in which they are to be warped, and leans the press against the tub where the slats season by the fire (Fig. 5). The back posts are always flared outward at the top and also require warping in a press; rockers, too, unless the board has a natural curve in it, must be cooked, warped, and slightly seasoned. Rounds, pegs, and slats are thoroughly seasoned in the oven but posts and rockers are left relatively green so they will shrink around the other pieces and hold the chair together without screws, nails, or glue.

Two wedges and the three "stobs" projecting from the face of Cornett's handmade work bench form the vice for holding posts securely while he mortises holes for slats. Each mortise requires about 25 separate strokes with hammer and chisel (Fig. 6). Holes for the rounds are drilled with brace and bit. Cornett again dresses the posts and begins assembling the chair (Fig. 7), fastening the joints securely with pegs (Fig. 11). Most chairmakers would have included another stage in which the posts and rounds are turned on a lathe but Cornett has not used a turning lathe since about 1950. If Cornett is making a dining or rocking chair he notches the rungs before carving the tenon on each end of the stretcher and inserting the rounds into the posts (Fig. 8).

The next step, called "barkin' the chair," is weaving the seat of hickory splints (Fig. 9). To get these strips of inner bark, the chairmaker must fell a young hickory tree, "unbark it" or remove the shaggy outer bark using a drawing knife, and peel off strips of inner bark with his pocket knife (called "jerkin' bark"). Unused strips are folded into "hands" or bundles until needed when they are then soaked in hot water to restore pliability.

The final step in constructing a settin' chair is to hold it against the window pane or place it on a level area—like the kitchen table—to be sure all legs are the same length (Fig. 10). For a rocking chair, of course, the arm rests and rockers must be dressed, shaped, and added to the chair (Fig. 11). The degree of tilt in a rocking chair is determined by the length of front posts in relation to the back legs: the longer the back posts are, the greater the tilt.

Although these are the processes used by Cornett in 1965 when my wife and I first met him, certain changes occurred last year when national publicity brought him a spate of orders. Previously he kept chairs on hand and traded for merchandise, took others to town to sell, offered them to neighbors, or peddled them along the roadside for a few dollars. Now orders are by mail and demand exceeds supply. To a great extent this is a situation of Cornett's own making because, like artists anywhere in American society faced with the problem of recognition and financial remuneration commensurate with the value of their art objects, he has purposely created many unusual chair designs to attract attention to himself and thus increase his sales. As a result, popular writers have used him as journalistic copy and Cornett has benefited with both increased sales and prices as well as praise for his workmanship.

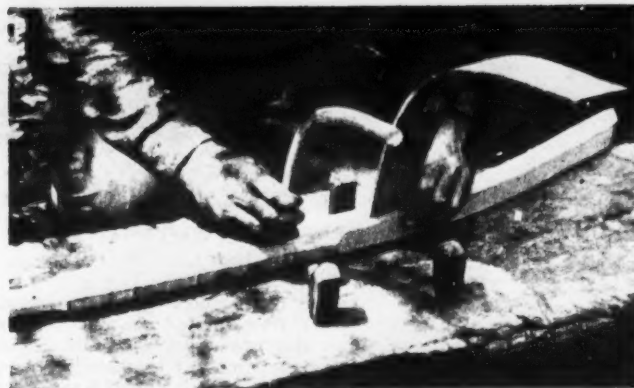

7



8



9



10

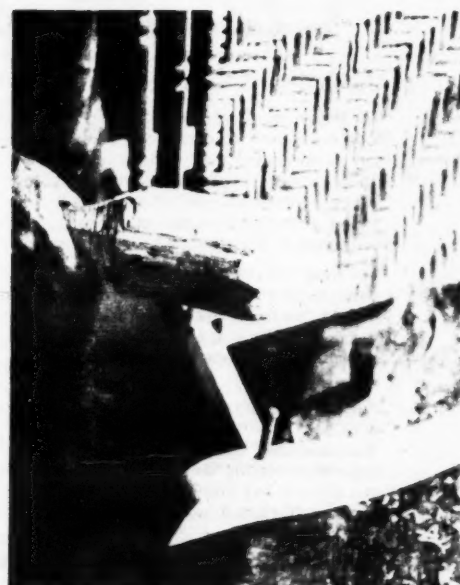

11

## NOTE

Photographs accompanying this article, taken by the author, are now property of Indiana University. At the conclusion of my field investigation all ethnographic data including photos will be deposited in the I.U. Folklore Archives for use by scholars. Taped interviews with Mr. Cornett and his uncle are available at the I.U. Archives of Traditional Music, accession number 66-204.F; the I.U. Museum of History, Anthropology and Folklore has examples of Mr. Cornett's work.

M.O.J.



## Remember—

### Yogurt

Here it is! The definitive yogurt recipe, courtesy of me. No special equipment, no watching the pot for hours & fussing about keeping it a special temperature—AT ALL.

### Equipment:

1 large pyrex (or otherwise heat-proof) mixing bowl  
Measuring cups, spoons  
Jars to store the yogurt in  
Oven

### Ingredients:

3 cups instant powdered milk  
½ tsp. unflavored gelatin  
1 tbsp. sugar (optional)  
1 large can evaporated milk  
3 tbsp. yogurt

### Water

### Instructions:

Soften the tsp. unflavored gelatin then add boiling water to make 1 cup. Add 1 tbsp. sugar (this takes the "edge" off.) and let the mixture cool a bit.

Preheat the oven to about 275° (250-300° range is O.K.)

Mix 3 cups instant powdered milk with 3 cups water. Add 1 large c evaporated milk, 2 more cups tepid water, and the gelatin mixture.

Add 3 tablespoons yogurt and stir thoroughly.

Cover the bowl, put it in the oven, and TURN THE OVEN OFF.

Leave it overnight, or about 8-10 hours.

Makes about 2 quarts, and is "fool-proof".

J. Lundquist

## Useful Odds & Ends

For those unable to afford a flour mill—an old food mill—the kind everybody's mother has—can be purchased 2nd hand for less than a dollar, is a pretty good substitute. The flour is like a combination of wheat germ & flour—makes an excellent bread—and is very economical. The grinding keeps you strong.

For flesh eaters who believe in bearing the remorse for their actions—hang some californian bay (laurel) in the carcass to keep away the flies, or use it as a flea collar or in your dog's sleeping quarters. Hang it on the wall, pop it in the soup.

Weave rags & old clothes into rugs on a frame with nails on either end in lieu of a loom. Weaves up fast if cut in inch strips. Makes a beautiful covering for floors & walls & keeps out wind & wet. Using string for warp, cost is about 10 cents a rug. Results with colors & designs unlimited.

Polyethylene sheeting a phenomenal material for all occasions. Put it under flooring for a dry, draft free floor use it as extra insulation on walls & windows when its cold. Put a water tank atop your house covered with black polyethylene—hook up pipes & fixtures—voila hot running water on gravity pressure. Polyethylene makes an excellent green house over a 2x4 frame certainly cheaper than glass.

Boil eucalyptus leaves in water and use the resulting infusion on poison oak. A very good astringent.

Ann Ligosky

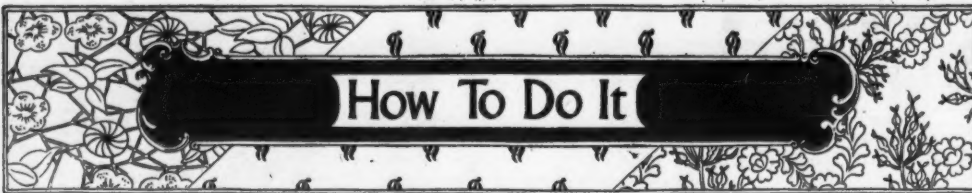

## Root Beer

What!! No directions for making home-made Root Beer?? What a perfect way to re-cycle those "twist-off" non-returnable pop & beer bottles. Simply wash very clean the bottles & fill as many with 4½ gallons Root Beer, using the Hires Extract & recipe. I can't find bottles of Extract in any store of late so I purchase direct from Hires:

Hires Division  
Beverages International Inc.  
Evanston, Ill. 60202

I have always used a bottle capper to cap the bottles but the bottle caps are now getting hard to find so I have been using the "twist-off cap" bottles, also used wine bottles and they work just as well altho some care must be taken with some of the "t off c" as they bend so easily.

Root Beer is a delicious beverage and all that is needed in making it is lg. pail, funnel, soup ladle & bottle with caps.

Mrs. M. Loftus  
So. Boardman, Mich.

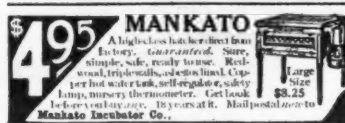

## Hand Washers

**A BEAUTIFUL WASHING MACHINE IS MADE OUT OF USING A "PLUMBER'S HELPER"—PUMPING IT UP AND DOWN IN ANY SUDSY LAUNDRY CONTAINER FROM BUCKET TO BATHTUB**

NORMAN SOLOMAN  
BERKELEY CALIF.

We asked Dale Fritz, a Peace Corps agricultural specialist and former Volunteer for Technical Assistance (VITA), who has years of experience overseas.

As it turned out, Fritz himself is the father of a simple hand-operated washing machine that has been featured for years in the Agency for International Development's (AID) *Village Technology Handbook*. What is the operating principle of the machine, we asked Fritz.

"Agitation, just agitation," he replied.

"You could take a stick and stand there and stir it," he added, "It's just the motion of the water. The clothes don't even have to move at all... It's just the water moving back and forth through the clothing that does the cleaning. The soap breaks down the dirt; and the water carries it away."

Well, we asked, if that is the principle, are there any other solutions to the washing problem that are simpler than yours?

Sure, he said. If you have a vehicle, throw your clothes into some kind of a closed container—like a milk can—add soap and hot water and put the container onto the back of your machine. Leave it there all day as you make your rounds—preferably over the roughest available roads—and when you get back in the evening you'll have a load of clean clothes.

That method has been used by bachelor ranchers in the western United States for years.

From *Volunteer Magazine*  
Published by the Peace Corps

## To Dry Corn For Winter Use

Sweet corn is the best. Husk it. Have a pot of boiling water—put your corn in & let it boil 3 min—then cut it from the cob & put it in pans in a warm oven. It must be stirred frequently, when perfectly dry, put away in bags. When wanted for use, soak it all night, next day boil it an hour with a little salt; before serving stir in a little flour, pepper & butter.

## To Freshen Walnuts

When Walnuts have been kept until the meat is too dried to be good, let them stand in milk & water 8 hrs. and dry them—fresh as new they will be.

## To Make An Improved Candle

Make the wick about half the usual size, & wet them with spirits of terpentine; dry them, before dipping, in the sunshine & the candles will be more durable, emit a steadier & clearer blaze.

## Waterproof Boots

A pint of boiled linseed oil, half a pd. of mutton suet, six ounces of clean beeswax, & four ounces of rosin, are to be melted & well mixed over a fire. Of this, while warm, but not hot enough to shrink the leather, lay on plentifully with a brush over new boots or shoes, when quite dry and clean. The leather remains pliant. The New England fishermen preserve their boots water tight by this method, which, it is said, has been in use among them over 100 years. They can thus stand in water hour after hour without inconvenience.

## To Make Soap From Ashes

To prepare a lye for soap, take a barrel without a bottom & place it on a board that has a trough to convey the water into another vessel; cover the bottom with straw, then sprinkle over a couple quarts of lime; fill the barrel with ashes; turn on cold water, a pail at a time—slowly! Continue to turn on water, at intervals of 3-4 hours the 1st, 3rd & 5th days. When the lye becomes strong enough to bear up an egg, put to 15 gal of it, 11 pds. of grease, heated to the boiling point. Stir it for 5 min. every day, till it forms soap. if it doesn't in 1 week, add a pailful of soft water.

Albert & Cindy  
Bass Lake, Ca.

## Write for free directions for soap making from:

Household Products Dept.  
Penwalt Corporation  
3 Penn Center  
Philadelphia, Pa. 19102

or  
U.S. Dept. of Agriculture  
Agricultural Research Service  
Clothing & Housing Research Branch  
Washington, D.C. 20525

Madeline G. Salmon  
Menlo Park, Calif.

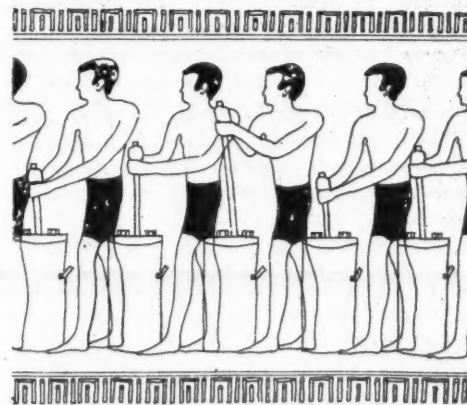

## Violin Repairing From Breugel

I learned violin repairing from a guy right out of a Breugel painting in Boston. Information which he passed along also is useful if you desire to repair a guitar. So—some how to and some where to.

### 1. Cracks in top or back.

on a violin you can take the top off and pull the split together—I would not suggest trying this on a guitar because of various construction differences. Best thing to do is fill crack with shaped splinters of wood (shaped to crack), spruce, or whatever the top is made of. These should be stuck in with a white glue Elmers is O.K. but "Tirebond," (which is slightly yellow (otherwise like elmers) is Best. Can be gotten at some hardware store—look around for it. More expensive but waterproof and strong. If can't find it is made by:

The Franklin Glue Company  
Columbus Ohio U.S.A.

eight fluid ounce container (like elmers) @ \$1.40

### 2. Tiny cracks can be filled with "Tirebond."

### 3. Broken neck. (guitar) where neck joins body.

glue on with epoxy—drill hole and insert 1/2 inch wood (birch usually) dowel. coat the dowel with "tirebond" before you stick in. DO NOT fill hole with glue and drive in peg (dowel) this will give neat demonstration of how hydraulic pressure can split wood. If tremendous strength is necessary use a thick metal screw. (drill out first)

### Broken neck other places.

Never have done it but some kind of pin, peg or dowel between the two pieces is highly recommended.

for finishing materials and glue of other types for use in guitars or furniture (either main business)

H. Behlen Bros. Inc.  
10 Christopher St.  
New York, N.Y. 10014

ask for catalogue and price list (they are separate) They are prompt. 1-2 weeks. (on east coast anyhow) they make a really beautiful white shellac.

### Home recipe #1 for a good violin/guitar varnish

1. combine their "sandarac" resin in a jar with alcohol (rubbing type) enough alcohol to cover the sandarac and 1/3 more.
2. leave it to dissolve for a week (until it all dissolves)
3. drain through cheesecloth
4. combine with equalpart of good quality white shellac
5. Powdered colour can be used with it. (get this at some art stores)
6. Thin with alcohol

Whole earth catalogue best thing ever to come down the pike.

Stephen Till  
Concord Mass. 01742

**Waterproof  
Your Shoes**



Protect them from rain, snow and slush—keep your feet dry. Make the leather soft and pliable—make your shoes wear longer. Do it with

**LEAKANOT**  
KEEPS THE FEET DRY

## Compost for the City

Reading somebody's back issue I was interested to find Gurney Norman making Suburban compost in his back-yard in Menlo Park, Cal. When I was in Brooklyn, I was sneakily making it in a plastic garbage can in my kitchen (after having been banned from the "living" room—whatever) ("Can I make compost in the living room, dear?")

I got great joy out of salvaging egg shells and coffee and rottables out of my throw away bags and storing them in my cache—One problem: it was very hard after awhile to stir everything up adequately. But it didn't really smell, if you didn't lift the lid, and pretty soon it seemed to be becoming earth again! We moved, then, to concrete Manhattan, and the compost came with us. In my concrete back yard I lined up half a dozen wooden milk boxes and scrounged earth from my country-going friends, and mixed the compost in with the earth, and planted everything that would grow in the shade in polluted air. Well, the tulips came up one year, coral bells are always there, and packisandra and myrtle are green all rear round. Violets grow beautiful green leaves but no flowers yet. Basil is *spectacular!*

I am not too scientific with this compost stuff. I probably am burning the plants, its so rich. But at least my back-yard has a green raggedy fringe to it. I miss the green fields and lush gardens and cool forests so much. I just pretend I'm an ant in my milk-box wilderness and everything seems better.

Janet Toy  
New York, N.Y.

## YOGURT

Your lengthy entry on yogurt surprises me. All those shennagins & contraptions to get 113°. Try this— you'll find it easier:

- 1 can condensed milk
- 1 can boiling water
- 1/2 can tap temperature water
- 1/2 c. active yogurt culture

Put in tightly covered containers & let stand for 3 hours.

Refrigerate.



"This was me before I read Lady Borton's foolproof recipe."



Works every time. If the weather is cool, put yogurt containers on a pan of warm water & let sit for three hours, then refrigerate. Granted, the yogurt is sweet, but good particularly when frozen.

Peace,  
Lady Borton  
Quaker Service  
Quang Ngai, Viet Nam

**Money In Poultry** Start small. Grow BIG.  
**and Squabs** For's Big Book tells how. Describes World's largest poultry farm; gives great mass of poultry information. Lowest prices on books, eggs, incubators. Mailed 4c. **F. FOY.**



## Jerk It

If given a chance to voice their opinions, wives tend to severely bad-mouth the less choice cuts of venison that generally wind up as ground meat. And for good reason. Without a fair amount of fat mixed in, hamburger loses flavor. The fat of deer having a rather strong taste it is properly trimmed out which makes it necessary to then add beef suet or pork fat to give the meat the flavor and consistency the modern palate expects from ground meat.

An excellent alternative is to forget the hamburger and instead, jerk the portions of the deer that don't wind up as chops or roasts. Jerky was a standby of the early travelers through Missouri and parts West because it keeps well, is simple to prepare and is a good source of protein. If dried to the point of "whang" leather, being neither too moist, nor crumbly, a small pack of jerky can provide a whole day's chew during those moments when the ducks aren't flying, the fish aren't biting, or (heaven forbid) when the dogs can't smell a quail. It beats apples as therapy for those outdoor frustrations because it won't bruise in your pocket and unless it's seasoned too heavily, only an occasional drink of water is required.

While you can jerk about any form of red meat, it's only that of venison that conjurs up visions of be-whiskered mountain men whose phenomenal ability to live off the land included making use of such meat preparation. Completely defatted, sliced a quarter-inch thick, about a half-inch wide and somewhere around eight inches long, lightly dusted with salt and pepper, and hung over a smokey fire of low heat until dried stiff, but not easily broken, the making of jerky is just that simple.

Perhaps the ancients would groan from beneath their rocky cairns over the way the moderns do it (heat lamp in the attic or in a 150 degree oven with the door propped open an inch for about four hours), but conditions change with the times. The climate of Missouri is a little humid for jerky to keep indefinitely so unless you've a way to package the meat with an air-tight seal, the freezer is the logical place for the supply—in which a paper or plastic bag will suffice until it's eaten.

From *The Conversationist*, Jan. 1970  
issue, put out by Mo. Dept. of Conservation  
written by Mac Johnson  
recommended by Pico Elgin, Columbia, Mo.

# A Two Pendulum Drawing Engine

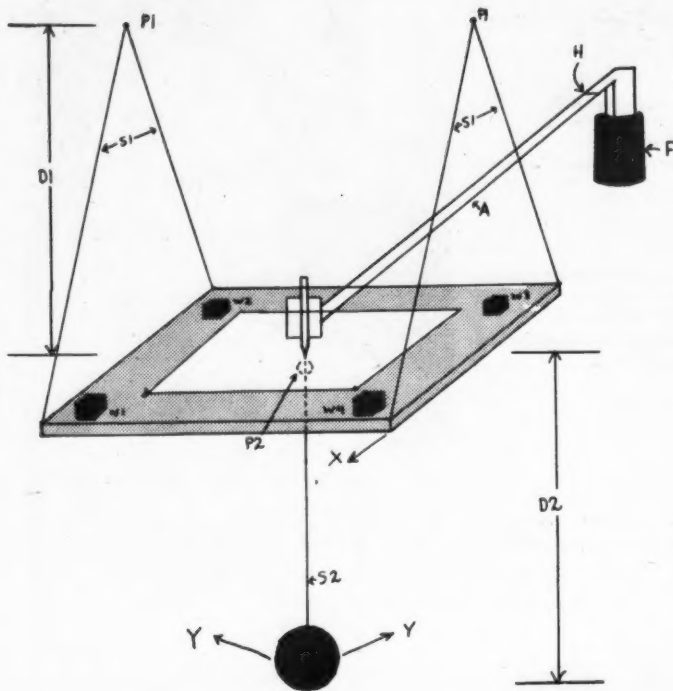

On page 42 of the July catalog (*Fun and Games*) Frank Raasch talks about a coupled pendulum device he calls a harmonograph. I enclose a design for a two pendulum drawing engine of this type. The design is not original with me. It's easy to build (took me about 4 hours) and makes interesting drawings — I enclose a few I made.

## EXPLANATION:

The engine consists of two pendulums—one is formed by the table *T* with its associated weights *W1*, *W2*, *W3*, and *W4* suspended from *P1* and *P2* with strings *S1*; the second is formed by weight *W5* suspended from the bottom of table *T* with string *S2*. A ball point pen is held in a vertical stationary position by arm *A*. Pen *B* and arm *A* are rigidly held together. They are permitted to move vertically by hinge *H*, but prevented from moving from side to side or back and forth by stationary base *F*.

To use the engine the table is deflected along *X-X* and weight *W5* along *Y-Y* with the pen raised above a piece of paper on the table. The table and *W5* are released, and the pen lowered carefully onto the paper. The pattern produced will be a function of distances *D1* and *D2*, the amount of the deflections and the instantaneous release angles and times.

## CONSTRUCTION DETAILS:

The table I used was a 15" x 20" piece of 1/2" plywood. Weights *W1-W4* weighed about 3 1/2 pounds each, and *W5* weighed 2 1/2 pounds. *D1* and *D2* are 3' and 1' respectively, but should be variable. Friction is an enemy of good performance. Some amount of pen-paper friction cannot be avoided, but may have to be reduced by counterbalancing arm *A*. Friction at pivot points *P1* and *P2* should be reduced as much as possible. Running the strings *S1* and *S2* through screw eyes is OK, but better results can be gotten by using a short section of firmly clamped nylon monofilament (get it from a fishing tackle store) and confining all the bending to it. I used a 1" piece of polypropylene piano hinge (Edmund Scientific) for *H*; a strip of celluloid or mylar clamped at both ends would do as well. In my version arm *A* is 2 1/2' long and base *F* is a camera tripod.

David Caulkins  
Los Angeles, Ca.



## A Birch Bark Crib



Lot of us are having babies and the need for a crib comes up. The old American design with its maple sides and back-and-forth rockers reminded us of a coffin. So we made one that could rock in all directions, with windows. We've enclosed some pictures.

The sides are of birch bark sewn to a wire frame (1 inch fencing wire) attached to a 1/2 inch thick piece of plywood cut in an oval. The wire is stretched around the frame and the four supports, stapled into place. Then the places for the windows are cut out with tinsnips (any shape window can be made using either plexiglas or other transparent window material (colors might be nice). We trimmed the windows and other places with soft leather glued with cement glue.

The universal bottom is a snow saucer covered with leather. It enables the baby to rock without anybody around. Watch it though, as they grow into the third or fourth month. In their sleep they have a tendency to crash (scrunched up at one down-tilting end). Unless the baby's an unmoving sleeper it's best to keep the saucer detachable for a solid sound sleep.

That's about all. The plans are here, with hopes that such a crib gives a child a chance to control and make their own universe, and see it as well.

The all of us  
Richard and Carol and Annalisa  
and Hobbit  
after Sept. 1, 1970:  
c/o New Experimental College  
Skyum P.R. Hørdum Denmark

P.S. The mattress is water-proof covered polystyrene made to fit into the shape of the crib. We had one made at a mattress factory for \$8 but it could be made as well as the crib. On the outside the rough white of the birch, on the inside, the inside of the bark for its smoothness. Best time to cut the bark is in the winter, or after a rain when the tree gives it up more easily. Don't take more than the top most layers, though, about the thickness of heavy paper. Be kind to the tree that's giving up something for your baby.

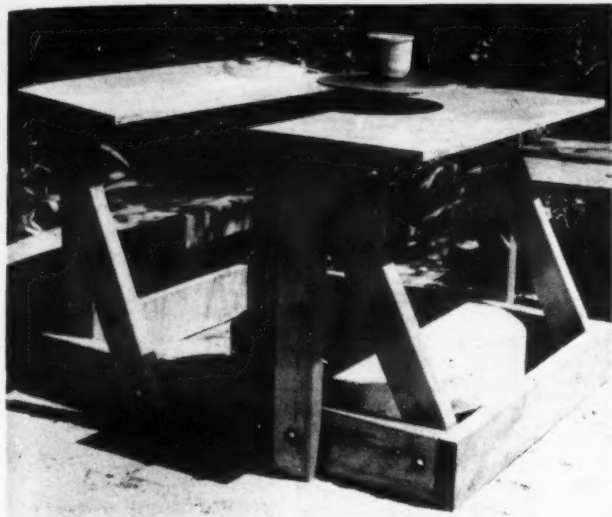

There are 5 major divisions in construction:

1. Frame
2. Shaft
3. Flywheel
4. Bearings
5. Wheelhead

1. The frame is the easiest of the parts to build. You will need a hammer, saw, level, plumb bob, brace and bit drill, nails and glue. First cut out all the pieces according to the cutting list, then assemble them according to the drawings. Glue and nail all the joints except where the seat and the table join the base. These joints should be bolted so that the wheel can be taken apart. It is helpful to have clamps to hold the glue joints together, but you can get by with just nailing and gluing. I use epoxy glue, but resorcinol or any other type of waterproof glue should work fine.

After you finish the frame, assemble it and level it carefully. Now locate the spot where the shaft will come up through the table. This is in the center and  $1\frac{1}{2}$ " in from the edge. Drop a plumb line from this spot to the brace that goes across the bottom of the base and mark that point for mounting the lower bearing later. Now locate a hole  $1/16$ " larger than the shaft size you are going to use through the table top where the shaft will come through it. Cut straight lines tangential to the hole to the table edge to make a "U" shaped slot. See the drawing. Then mount the footblocks on the table vertical wherever they seem comfortable. This completes the frame.

### 2. The Shaft.

I use 1" Dia. cold rolled steel round bar. If you are buying a commercial wheelhead use  $3/4$ " Dia. You may be able to get shaft material at a junkyard. If you do, be sure to select a straight smooth piece. Cut a piece  $26\frac{1}{2}$ " long and weld or braze a  $1/2$ " cap screw onto the end. This fits into the lower bearing, so be sure you have it right in the center and sticking straight out. Now weld some pieces of reinforcing rod onto the shaft to provide holding power in the concrete. They should be about 24" long so they stick out 12" on each side, weld them on at right angles to the shaft and  $1\frac{1}{2}$ " up from the bottom end of the thick part of the shaft. This completes the shaft.

Note: If you use a commercial wheelhead, you may have to change the length of the shaft to accommodate it. Check this out carefully before you start.

### 3. The Flywheel

I cast the flywheel out of a rich concrete mix with reinforcing rod to further strengthen it.

Use approximately these proportions:

- $2/3$  sand and gravel
- $1/3$  portland cement
- 1-2% calcium chloride
- enough water to make a smooth mix

If you buy Sak-O-Mix or Quick-Mix you should add at least 10 pounds more portland cement to each sack to make the finished concrete strong enough. The calcium chloride accelerates the cure time. It takes about 2 weeks to cure without it; about 2 days with it.

The flywheel is 27" in Diameter, so you have to make a round form that size. Cut a 27" circle out of plywood, masonite or even heavy cardboard and cut a hole in the center  $1/16$ " larger than the shaft size. Set this on a perfectly level surface which is raised enough to allow the end of the shaft to stick down about 1". To make the sides of the form, wrap a piece of thin, flexible sheet metal or heavy paper around the bottom of the form and wire it in place. The sides should be  $3\frac{1}{2}$ " high. Brush some oil on the form and then put the shaft through the hole so the bolt welded on the bottom sticks out of the bottom of the form. Make sure the shaft is perfectly vertical and then mix the concrete and pour it into the mold. When the concrete is partially hard, gently brush and wash the top surface to expose the aggregate. This gives a nice rough surface for kicking.

This completes the flywheel.

### 4. The Bearings

I use a Fafnir RA008NPPB for the bottom and a babbitt bushing for the top, but I would recommend Fafnir FLCT bearings for both the top and the bottom as they have mounting flanges and are very easy to install. Get a half inch bore for the bottom and a bore the same as the shaft size you use for the top.

Mount the lower bearing on the base brace right over the spot you marked. Bolt it through the base brace and countersink the holes on the bottom so that the bolts don't stick out.

Set the flywheel into the lower bearing and then put the table in place and bolt it to the base. Then push the upper bearing onto the top of the shaft and bolt it through the table top. Now everything is complete except for the wheelhead. If you buy a commercial head just set it in place and tighten up the setscrew. If you are making your own wheelhead see section 5.

### 5. The Wheelhead

Get a 12" diameter circle  $1/4$ " thick from a place that does flame cutting of steel or you may be able to find it in a junkyard. To make the hub that holds the head to the shaft get a piece of black iron water pipe 1" IPS Schedule 80 one inch long. Put it in the lathe and face both ends and bore it out to a snug, but sliding fit on the shaft. If you use a  $3/4$ " shaft use  $3/4$ " IPS schedule 80 pipe. Place it directly over the center of the wheelhead and clamp it down securely. Then weld or braze it to the head.

This completes the wheelhead.

# How to Build a Lipton Kickwheel

These are the wheels which I make and sell in Berkeley for \$80. If you want to do the carpentry yourself, I sell just the mechanical parts for \$40. If you want to do the whole thing yourself, these instructions tell how to do it.

The first thing to decide is whether to buy a commercial wheelhead or to make your own. To make your own you need access to a lathe. If you buy a commercial head use  $3/4$ " Dia. shafting. This is the size that most commercial heads are designed to accommodate. I use 1" shafting, but there should be no problem changing to  $3/4$ ".

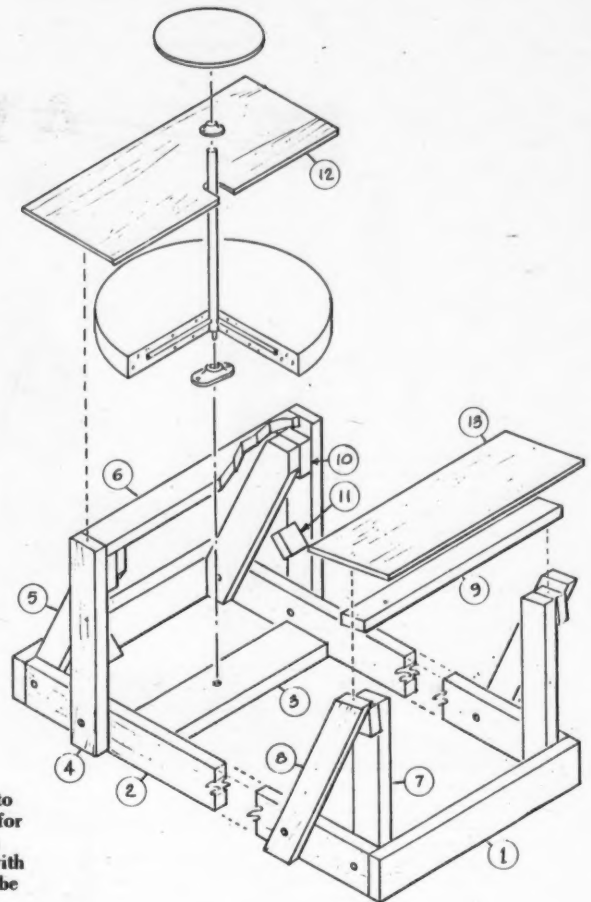

You should be able to get all the materials for less than \$40. If you have any problems with the construction I'll be glad to help you by telephone, letter or personally.

Paul Lipton  
1624 Virginia St.  
Berkeley, CA 94703  
(415) 549-0368

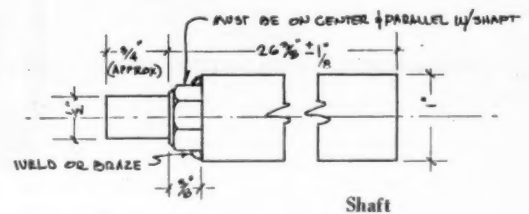

### CUTTING LIST

Index	Description	Quantity	Dimensions
1	Base	Two	2"x6"x32 1/4"
2	Base	Two	2"x6"x39"
3	Bottom Brace	One	2"x6"x29 1/4"
4	Table Vertical	Two	2"x4"x26"
5	Table Brace	Two	2"x4"
6	Table Cross	One	2"x4"x32 1/4"
7	Seat Vertical	Two	2"x4"
8	Seat Brace	Two	2"x4"
9	Seat Cross	One	2"x4"x32 1/4"
10	Spacer Blocks	Four	2"x4"x3 1/2"
11	Foot Blocks	Two	2"x4"x3 1/2"
12	Table	One	3/4" Ext. Ply. 36"x15"
13	Seat	One	3/4" Ext. Ply. 36"x12"

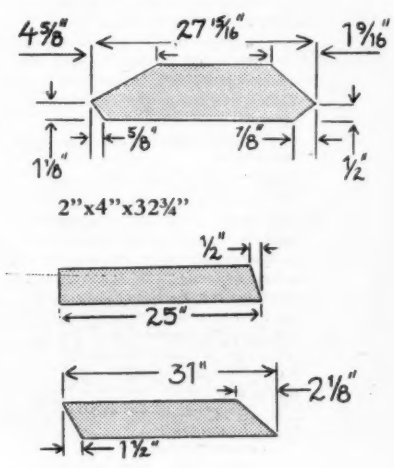

Ham-

I don't dig your land game thing. Why I would want to go out to some groovy land and rip it up by living there is beyond me. The problems exist as mans present life style and the solutions must be within and competitive with that life style. In short I think you've got to subvert the cities by doing and showing in their context. Maybe it's impossible but if you're out having a jolly time in the mountains/woods while the cities go to hell ultimately they take you with them. Isolation just doesn't work; now if you are trying to have a personal good time that is something else.

Have been a radio amateur for about about 17 years (first general class then about 10 years ago extra class, also commercial first class, second class telegrapher). I've been active in the national traffic system and did some NCS work on TWN. Your proposal as mentioned on p. 49 last WEC looks unworkable. There are thousands of freaks looking for old mimeo machines and other junk and transmitting their wants all over the earth on short wave would only add to that garbage. I can see the possibility of a freaks conversational network or a hams for Social change thing or whatever but you have to face the fact that anyone doing anything controversial on the air will get interference from other disgruntled members of the fraternity (e.g. student information net of recent times). I went to Wash DC last Nov 10-15 to set up communications with CB equipment for the march against death and rally and all the good Americans tried to stamp us out. Skilled operators can get thru interference especially on CW but it is a tedious process (though the challenge is fun). There may be communes that would benefit by having a radio communications outfit but on the other hand that is probably one of the things they are trying to get away from.

As an amateur I'm willing to help people get licenses and with consideration of what is practical; however I think it is important to keep the realities straight. Rather than doing a serious uptight operation I think it would go better as an informal humanistic endeavor. In my travels I've only met (that I know of) one freak who is an amateur but there seem to be a few around.

(ARRL is always printing request for special ham groups; I've considered asking for other guys/gals who have committed civil disobedience/ gone to jail, delivered their babies at home, belong to the War Resisters League, belong to the American Kitefliers Association—by the way have you reviewed them? — etc.; maybe instead you could put in a request for hams who are freaks!)

Stay clear of the wouff hong,  
Peace, resist,  
John K. Green  
Box 1038  
Boulder, Colorado, 80302

### Radical Software

We get letters—saying how encouraging, enspiriting, possibility-expanding the *Whole Earth Catalog* is—embarrassing amount of gratitude in these letters. Well, it's how I feel about Radical Software; A double handful of fast young heads have entered do-it-yourself TV and gotten acquainted with each other, and now started a tabloid of mutual read-out, aiding each other's scuffle for equipment, audience, comprehension, concepts, values. They sense power (95% of U.S. homes have TV) and unexplored territory (broadcast TV still scarcely seems to know what it is) and the hard cider of dwelling on evolution's imploding edge (maybe [always maybe].) In a way it's about time: we have head radio, head records, head books, magazines, newspapers, head movies; very little head TV. [Beware beware of controlling all your inputs lest ye become your own caricature.] These are TV heads, getting restless, with a fine access publication. I hope it stays solvent and publishing. High content goods.

—SB

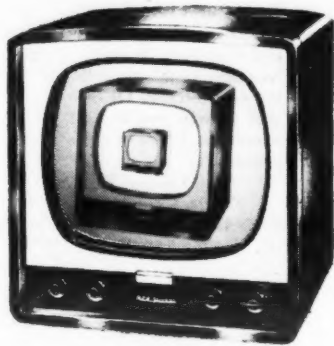

### The Crush of Television

"There are 60 million homes in the United States and over 95 percent of them are equipped with a television set. (More than 25 percent have two or more sets.) In the average home the television is turned on some five hours forty-five minutes a day. The average male viewer, between his second and sixty-fifth year, will watch television for over 3000 entire days—roughly nine full years of his life. During the average weekday winter evening nearly half of the American people are to be found silently seated with fixed gaze upon a phosphorescent screen."

"Water systems engineers must build city water supply systems to accommodate the drop in water pressure occasioned by the toilet-flushing during television commercials.

GUNS, KNIVES OR VIDEOTAPE\* works this way. Two people, each with a portable pack and camera, face off fifteen feet apart. At a given signal they start "shooting" each other. Both roll tape continuously for five minutes. Then both tapes are played back simultaneously on two monitors set up side by side. The area should be large enough so that participants can move around. Variations are possible. Doubling up in teams of two, doing it in a mirrored room, setting up a third camera on a stationary tripod to catch the whole duel for playback with the participant's tapes. \*Executed in Pontiac, Michigan

Vic and I recorded a conversation between us using full body shots on a split screen. We were seated facing each other. A week later we played the tape back using slow motion and no sound. We both sat facing the screen imitating the kinetics of the other on the screen and verbalizing how we felt from going through those motions. It was extraordinary. Holding my head and rocking back and forth in imitation of Vic. "Yeah, I'm listening to what you're saying, Ryan, but I'm really getting ready to strike back." Following a diminutive hand gesture "Let me make it nice and small, Ryan, so that you can understand it," Vic was scoring on me in a similar way and we were laughing our heads off. What was even more extraordinary was when I woke up the next morning, I felt like I was wearing his body. That I had it on. I called up Vic and started telling him how I felt about the relation between his/my stomach and shoulders, stomach and head, torso and legs, etc. etc. Each time Vic confirmed I was right on. For the next few weeks I found I could recall this sense of his body when I wanted.

by PAUL RYAN April 11, 1970

-Com

In the March \$1 *Catalog* you were wondering about how to fit electronics into your catalog better. It seems to me that electronics equipment is relevant to the very important business of communicating with one another. Radios, transceivers, hydrophones, ultrasonic translators, and tape recorders certainly are significant tools. However one of the most important communication tools, (in my opinion) is a shortwave receiver. Listening is the beginning of all communication. With even the humblest shortwave receivers one can tune in many different nations all around the globe. Americans have neglected shortwave radio but the rest of the world (mainly other governments) is broadcasting it's opinions, viewpoints, philosophies, music, literature and drama for anyone to examine. It is free to anyone with a shortwave radio.

The simplest way to start listening is to turn on any shortwave-ready radio you have. Reception is better if you attach a long antenna and a good ground. Reception is also better after dark. You may have a good shortwave receiver in your attic or a \$5 to \$25 Salvation Army Store radio will serve. Almost anything made after 1932 is liable to work well. Of course if you have more money a store-bought receiver or kit would be a fine tool. I hope some of your correspondents will be reviewing receivers and listening guides.

Besides ham radio it seems to me that souls interested in underground (and aboveground) radio and tv ought to check the radio & tv trade journals for the names of brokers in used broadcast equipment. With the introduction of color tv, multiplex fm and transistors a lot of good equipment has been obsoleted. Presently much of this stuff is sold to less affluent parties overseas. Also since many police and fire departments have changed from broadcasting on 1700 kc. (which is just on one edge of the broadcast band) to vhf and uhf bands I'd bet that there is some modest power gear on the market that would be fine for am broadcasting with merely a new crystal (like \$10 and a tune up).

I have been reading the *Whole Earth Catalog* to a blind (freak) friend of mine. He digs it. He is on his way to California and I've given him your address. He would like to talk with you about how the *Whole Earth Catalog* idea might be made more useful and relevant to the small (but growing) blind freak community. Also, his visit might catalyze us—the sighted ones towards a more effective consciousness of all our brothers who have been dealt unique sensory bags Jim is his name.

I just read the above paragraph to Jim and he says: No Lee, I want to de-emphasize the differences. Period.

Lee McKusick  
Chimayo, N.M.

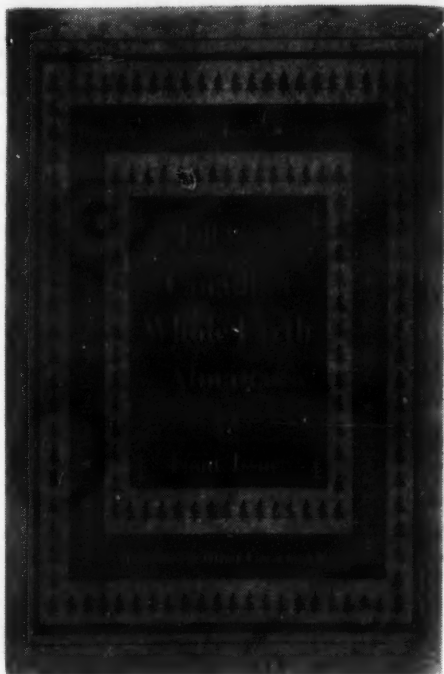

### Canadian Whole Earth Almanac

Canadian Whole Earth Almanac is out, and it looks good. The fall Catalog's gonna review it. In the meantime, you can get it from:

The Canadian Whole Earth Almanac  
341 Bloor Street W. Room 208  
Toronto 181, Ontario

single copy \$3  
year subscription \$9 (4 issues)

### Canadian Wood-Frame House Construction

Free

From:  
Central Mortgage & Housing Corp.  
Ottawa, Ont.

Explains in detail how a wood-frame house is put together from the location and excavation of the planned site, to building and final finish work, step-by-step. Fully illustrated; you'll have that house up in no time.

### The Preservative Treatment of Wood The Seasoning of Lumber The Structure of Wood

\$.35 each

From:  
Queen's Printer  
Daly Bldg., corner Mackenzie-Rideau  
Ottawa, Ont.

### The Wilderness Cabin

Calvin Rustrum  
1961; 169 pp.

\$7.25 postpaid

From:  
Collier Macmillan Canada Ltd.  
539 Collier-Macmillan Drive  
Galt, Ont.

An almost complete book (details are not extensive, but you can figure them out) on site selection, use of tools, and building of a log cabin, with diagrammed instructions. It's a way to erect a shelter in the woods with very few tools and know-how.

### Human Biocomputer

BACK IN PRINT. After a year of absence, this landmark paper is back at a lower price (formerly \$7.95, now \$1.50).

John Lilly has worked for a long time with sensory deprivation, pursuing the notion that relieving the computer (mind) of many of its environmental-survival chores frees it to attend more fully to self-investigation. Of late he's added LSD to the process and has found ways to flourish and discover within this doubly floating condition.

The paper HUMAN BIOCOMPUTER is the best internal guidebook I've seen—far more practical and generalized than transcendent Eastern writings or wishful Underground notes. Though it's not the whole story by any means, it makes an open start on fresh language and powerful technique for the frontier.

An additional advantage the paper offers is the opportunity to learn and explore computers without requiring money or administrative approval. You inherited and grew everything you need, and it's free.

(Suggested by Ralph Metzner)

The major problems of the research of interest to the author center on the erasability, modifiability, and creatibility of programs. In other words, I am interested in the processes of finding metaprograms (and methods and substances) which control, change, and create the basic metaprograms of the human computer. It is not known whether one can really erase any program.

I believe that by using certain methods and means some of which are presented in this work that truly talented and dedicated individuals can forge, find, and devise new ways of looking at our minds, ways which are truly scientific, intellectually economical, and interactively creative. Consider for example, the case of the fictitious individual created by the group of mathematicians masquerading under the name of "Dr. Nicholas Bourbaki."

This group of mathematicians in order to create a mathematics or sets of mathematics beyond the capacity of any one individual, held meetings three times a year and exchanged ideas, then went off and worked separately. The resulting papers were published under a pseudonym because the products of this work were felt to be a group result beyond any one individual's contribution.

In the maximally attenuated environment (92 to 95 degrees F. isothermal skin, saltwater suspension, zero light levels, near-zero sound levels, without clothes, without wall or floor contacts, in solitude in remote isolation, for several hours), the addition of LSD-25 allows one to see that all the previous experiences with "outside screens" are evasions of deeper penetration of self (and hence are "screens" in the sense of 'blocking the view behind,' as well as 'receiving the projected images').

### Programming and Metaprogramming in the Human Biocomputer—Theory and Experiments

John C. Lilly, M.D.  
1967, 1970; 112 pp.

\$1.50 postpaid

from  
WHOLE EARTH CATALOG  
558 Santa Cruz Avenue  
Menlo Park, Ca. 94025

copies for resale from

BOOK PEOPLE  
2010 Seventh Street  
Berkeley, Ca. 94710

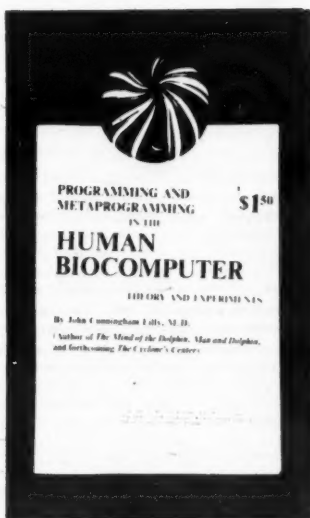

### Boy Scout Merit Badge Series

I would like to recommend the Boy Scout merit badge pamphlet series (all but the Cooking book which is obviously worthless). They are only 45 cents and present a thorough introduction to a wide range of subjects of presumable interest to boys. These include Animal Industry, Architecture, Astronomy, Beef Production, Beekeeping, Bird Study, Botany, Camping, Canoeing, Cooking, Corn Farming, Dairying, Farm Management, First Aid, Fishing, Fruit and Nut Growing, Gardening, Geology, Hiking, Insect Life, Journalism, Leatherwork, Metalwork, Nature, Pioneering, Plumbing, Poultry Keeping, Public Health, Rabbit Raising, Railroad, (for people who want to get the most out of participatory democracy), Rifle and Shotgun Shooting (for people who didn't get the other one), Small Boat Sailing, Small Grains, Soil and Water Conservation, Space Exploration, Weather, Woodcarving, and Woodwork.

Of course there are many more. Most of the "Scoutcraft" like hiking and camping, and pioneering can be found in the *Fieldbook*. But 45 cents ain't much to pay for an introduction to small grain farming and basketry.

If you have a garden you probably hate things like cutworms and aphids but are also afraid of giving yourself that last dose of chlorinated hydrocarbon that will do it. Solution: plant things like garlic, onion and chili pepper along the border of your garden and through the middle if it's wide. Bugs don't like these plants and will avoid them. Consequently they will also avoid your garden. If they don't then crush a chili carefully into about a quart of water, add a crushed clove of garlic and sprinkle or spray the stuff on your plants. This will give all the bugs heartburn and they will vow never to patronize your garden again. Good bugs to have in your garden are lady bugs, ants, wasps, bees, and spiders. Even safe insecticides will kill them, so beware. Cutworms and other caterpillars aren't numerous and should be picked off by hand.

Dairy lovers would like to know where to get manual non-electric churns and cream separators. Yes, we would like to know that. The Marshall Pottery Company in Marshall, Texas, still makes crocks in all sizes. They have a three gallon crockery dasher churn. It is cheap, about \$3 or \$4. But we are looking for one with rotating paddles and a crank. Say, my uncle Fred is a crank. I am exhausted. My brain is limp and drained. I have given you all my knowledge of the wise world. Good luck for the universe.  
Piece and undermining,  
RD and JL Hamilton

dear you people,  
merit badges butter churns peterson field guides.  
wahoo  
my aunt babe has a crankhandle half gallon jar paddletype butter churn. maybe if you wrote to her. manual separators are scarce. babe converted hers in about 1950. you can get butter if you shake a jar of cream long enough. the way i understood paddle type churns was that it enabled a kid to churn a few pounds of butter without more than a few blisters and a bum shoulder. i've been hunting.  
peace,  
j.d. smith

### J.D.'s Insect-Food Bug

Re: Recipes for eating insects.

This recipe comes from parts of Asia and Africa. Insert fried peanuts into crickets' abdomen (preferably cleaned). These prepared crickets are then fried. They are supposedly very tasty to those whose palate accepts them.  
James Do (J.D.)

On page 49 of you July catalog, "J.D." asked for recipes for eating insects. I found this one in *Science Digest* for June, 1970, page 21. That's volume 26, number 6. I quote:

- 1 pint termites
- 1 Tablespoon vegetable oil
- ½ teaspoon salt

Remove termite wings, if any. Spread termites on stone to dry in sun. Put oil in pan and spread dried termites on it. Toast over hot coals until almost crisp. Sprinkle with salt.

"It helps the flavor, say those who have tried the recipe, if you eat the termites in handfuls."

*Science Digest* credits the Bantus with this recipe and reminds readers that there is "lots of vitamin B" in termites. Termites aren't all that plentiful in most of the U.S., but I suppose that the recipe would be just fine for ants.  
Frank Walsh



### Grasshopper Jam?

There's a bright side in the battle against the bugs, which is one front in the larger war against pesticide pollution and worldwide hunger.

"If we can't beat 'em, we'll eat 'em," cheerily predicts Dr. Howard A. Schneiderman, dean of the school of biological sciences at the Irvine campus of the University of California.

"In the event we start to lose the battle, the war itself is not really lost," he says, "for insects themselves are an excellent source of protein... Eating bread fortified with insect meal (is) no different than eating bread fortified with fish meal."

Proteinwise, that is.

This is not a recipe, per se, for insects but it does imply that insects are very good and could be used to eat; probably should be used to eat!

Pam Newbury



### The American Bison

You have recently received a letter to us from a Mr. Nikolai Goodman of Providence, R.I. Here is what I wrote to him:

Dear Mr. Goodman:

There are no longer any wild buffalo—they are all on game refuges, game preserves, ranches, or in zoos. The species is no longer threatened with extinction. The land available for the grazing of buffalo herds is now limited, so herds must be thinned to preserve the health of the herds and maintain the soil and grass on their ranges.

If you wish to increase the number of buffalo in existence, you ought to buy or lease some appropriate grazing land, buy a couple (at least) of the animals, and care for them. Contact the nearest bison range for information.

I assure you that animals are not slaughtered to fill our small orders for hides and horns. The animals are killed first, then bids are taken for their meat, hides, etc.—at least, that's the most usual procedure with government bison herds, I believe. These buffalo would die whether or not we sold hides and horns.

Your regard for the bison is most commendable.

So that's what I told him. I've never killed a bison in my life and never will. I wish he were as interested in the health and welfare of the American Indians as he is in that of the American bison.

Rosemary Lessard  
(Mrs. F. Dennis Lessard)  
Del Trading Post  
Mission, South Dakota

### Memories, Dreams, Reflections

This is the man who wrote the Foreward to Richard Wilhelm's translation of the *I Ching* in 1949 which will give you an idea of where his mind was when most of us were kids or simply were not.

You don't need to know any psychology, other than the kind you learn by living, to prophet/profit from this one, especially the last two chapters: "On Life After Death" and "Late Thoughts." This man lived eighty-five years during times of tremendous change: Automobiles, household electricity, world wars one and two, sputnik, these are mentioned not at all or only casually referred to in explanation, parenthetically, like footnotes. He is the most introspective person I've ever read about and all of his discoveries in Psych. were due to his self-analysis. As you read the book, (felt a great deal of sorrow, knowing he was dead, after finishing it I felt he had somehow won a battle or beaten death, or found something better than life or some such phrase. Transcended is the currently popular word.

Anyway, this man is a seer. If it weren't for my dislike of the label I'd say he was a hippie but he is really much more than that; he is a Man.

Jung isn't selling anything. His book is only a map, not a commandment or theology, if you don't want to make the trip it's still interesting to see the route traced out.

Rick Williams  
El Paso, Texas

### Memories, Dreams, Reflections

Carl G. Jung

\$2.45 postpaid

from:  
Random House, Inc.  
201 E. 50th Street  
New York, N.Y. 10022

Last, last minute corrections: *Boffers* are no longer available by mail from *Whole Earth Catalog* or *Jack Notting-ham*... but *Whole Earth Catalog* now carries *Geo-D-Stix* for \$8.95 postpaid.

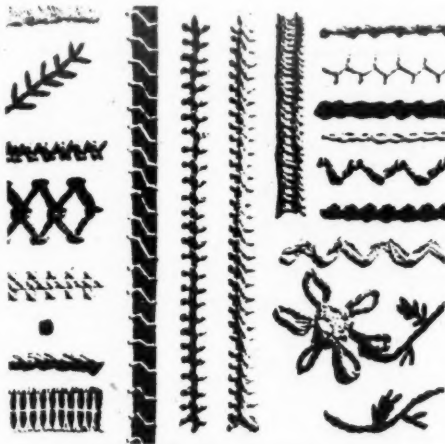

### Embroidery Stitches

I'd like to tell you about a great reference book. I don't know if you used it in the past but it's great. It's *One Hundred Embroidery Stitches* by Coats & Clark's #150. It's a wonderful pamphlet and available by mail or may be found in any variety store just about everywhere. It's very easy to follow. Myself and friends, who never embroidered before found it very good and were able to create wonderful designs on our first try.

The pamphlet just lists the stitches with very clear instructions and leaves the rest to your imagination. It covers all the different kinds of embroidery such as Drawn Fabric (good for smocking blouses), Insertion stitches, as well as more traditional stitches. I think there's no other book like it for its price (35 cents plus 5 cents postage).

Write to: Coats & Clark  
Dept. 495  
GH90  
Fairlawn, N.J. 07410

Keep up the good work.

Muffin Britten  
Atascadero, Calif.

### Speed vs. Time

Dear Sir,

Would you please send me some information your catalog, and please tell me if there's any place advertised where I can get the process to make "speed" (efidimene or benzidrene) in it, or other drugs.

Charles

charles,

for some time now there have been posters in most youth-places in california saying, *SPEED KILLS*. I tend to believe them. if you really want to turn yourself on, change your head, get away from it all, i'd suggest trying something more natural than pumping your body full of chemicals. a few diciplines, like watching a flower opening to the sun. it takes a little time, but does change your head.

peace,  
j.d.

### Swimming Pools As Reservoirs

Water being a basic necessity for life, especially in the country where it doesn't just run out of faucets, we'd like to pass along an idea for water storage. that we have been using for over a year. A swimming pool—the kind you assemble yourself with aluminum frame and plastic liner—makes a totally adequate storage tank.

When we were planning our water system, we investigated the various ways of storing water, ranging from homemade cement tanks (tricky to build so they don't crack) to expensive redwood tanks (approximately \$600 for 5000 gallons and you have to keep them full or the wood gets screwed up & leaks). Finally, and luckily, we hit upon the idea of a swimming pool. We got ours (15 ft. diameter, 5500 gallons) during a *Monkey Wards Spring Catalog Sale* for about \$160—a real buy, but even at regular prices (up to \$200) this beats the redwood tanks by quite a bit, and it's easier to install than a cement tank. Sears and Western Auto also carry similar models.

We installed ours on a hillside above our house (after leveling and shoring up a 15 ft. area), and we siphon the water to our house and garden using good old gravity (the tank is high enough above us so we have adequate pressure). The plastic liner (very good heavy duty) imports no taste to the water, and can be replaced for about \$40. The plastic cover you can buy to go with the pool (about \$12) is worthless, so we bought heavy black plastic, draped it over a cone-shaped frame we built of 2x4's (to keep the plastic from hanging down in the water—it's heavy!), and secured it around the circumference with the nylon rope that came with the original cover.

If you're going to use a siphon, curve the pipe (we used a length of copper pipe connected to our regular plastic pipe) up off the bottom of the tank 6-10" & cover the opening with screen to keep out the silt (which settles to the bottom), bugs, & frogs.

If you install this tank on a hillside, try to find a spot that has a couple of big trees or a large stump on the downhill side (our tank butts up against an old burned-out redwood), so that if the earth shifts the whole pool won't slide downhill—an unlikely occurrence, but you'll sleep better!

Upkeep is minimal. We emptied ours completely after a year to clean the liner, and found that it really wasn't necessary (the plastic looks grungy, but isn't really dirty). We "fill" ours about once a month (more often in the summer)—we don't let it get completely empty or the siphon wouldn't work. It costs us less than \$2 per month in electricity to pump water uphill from our spring (if you're smart you'll put your spring above your tank—but we didn't have a choice!).

Hope this suggestion will solve someone's water-storage problem as well as it solved ours. Will be glad to answer any questions we can.

Ron & Liz Peck  
Star Route Box 83  
Myers Flat, Ca. 95554

## Correspondence Schools

You asked for comments on correspondence schools in relation to a suggestion in your spring issue, and I happen to have a few. I worked with a reporter gathering information for a story on the subject, and the results were depressing. (The story appeared in the *New York Times* on May 31, 1970.)

The catalog suggestion was to write the National Home Study Council for information about courses. If someone is bent on taking a correspondence course, the Council is the best source of information for halfway reputable schools, because the Council is the only nationally recognized agency in the field. It has established minimum standards for business and educational operations and is supposedly held, by Federal law, to the same standards as the agencies which issue accreditation to resident-type schools and colleges. However, this does not hold up for there is little regulation by the states or the Federal government. Last fall, for example, the accrediting commission of the Council examined 6 Crowell-Collier institutions (remember your friendly Collier's Encyclopedia salesman?) and withdrew their accreditation. The major Crowell-Collier school is LaSalle Extension University of Chicago, and without its accreditation, the State of Illinois was required by Federal law to change its status. Among other things, this would have made LaSalle ineligible for any funds from any of the G.I. and Veterans education bills. But nothing was done. (An unknown number of LaSalle executives purchased tickets to a \$100-a-plate political dinner for the Superintendent of Public Instruction for the State of Illinois.) Crowell-Collier also filed an anti-trust suit against the Council. Having no funds for a court fight and no encouragement from any of the Federal agencies, the Council accepted the Crowell-Collier settlement out of court, reaccrediting LaSalle and the other schools.

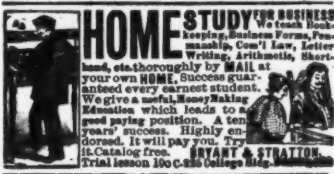

So, although the National Home Study Council has set standards, it has no way to enforce them, thus leaving the question of quality up to the individual schools. Two schools which have maintained high standards are the advanced Trade School and the American School, both in Chicago and both offering a wide range of courses. These two schools run credit checks on applicants, administer valid admissions tests, actually turning away those who fail, and pay their salesmen a salary rather than a commission based on how many people they sign up.

Many schools don't have admissions tests, and those that do often make the tests ridiculously easy to pass. Many of the schools pay no attention to the results of their tests anyway. In other words, for many courses, if you can sign on the dotted line and make the down payment, you've met all the necessary requirements.

Many of the courses are very over-priced for what is provided. Private correspondence schools charge from less than \$100 to more than \$2500 and the average course costs between \$300 and \$600.

In many places, there are less expensive alternatives available to home study courses. Many universities, colleges, local government adult education programs, churches, YM and YWCAs, civic groups, etc., offer courses in a wide variety of subjects to the general public, usually for nominal fees and/or the cost of any materials. For instance, if you live in New York, check the Photography page in the Entertainment Section of the Sunday *New York Times* for locations, dates, and costs of beginning and advanced courses in photography. Your local U.S. Department of Agriculture extension office makes available a great amount of information and demonstrations on farming. Check with local companies in your field of interest; many run their own training programs. I also know of people who have actually apprenticed themselves to local craftsmen, one to a harpsichord maker, the other to a cabinetmaker.

It is much easier to check the reputations of courses offered locally, but if nothing is available then write the National Home Study Council for a list of schools offering the course you want. Send away to all the schools suggested, and from the ensuing, and never-ending deluge of promotional mail, pick the one which seems to be the most reputable and seems to offer the exact course or training that you want.

Finally, should you sign up for a course and then find out that it isn't what it was advertised to be, send your letter of resignation by registered mail.

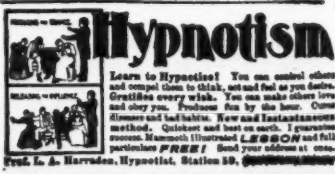

However, if you want to get rich quick, which is the result promised by most of these schools, and you have no scruples about ripping off unsuspecting poor people, instead of taking a correspondence course, I suggest you try selling one. All you need do is follow the advice which a Dr. Richard S. Frazer gave to members of the Association of Home Study Schools. Dr. Frazer was head of the now-defunct Christy Trade School in Chicago and he received his doctoral degree from something called the "Neotarian College." Dr. Frazer's suggestions: Immediately offer courses in 200 subjects and decide on public response to an advertising campaign which

## Progressive Colleges?

Do you know of someplace I can write which would send me a list of Progressive Colleges around the United States? I would appreciate it greatly if you could send me any addresses that you know of where I might be able to obtain such information.

Thank you very much.

Lisa Fischel  
Brooklyn, N.Y. 11230

You're one of many. We need a *New Schools Exchange* for the college level. Any clues?

## Apprenticeship Program—Teenage Trips

Tired of high school? Here's an option. *Traveler's Directory* will list your name and address and what you want to learn and where you're at. Use the Directory listing form or a sheet of paper and be as clear as you can about what's essential in your life, what you can't be happy with or without, or whether you are willing to fit yourself to someone else's rules for awhile. We'll also list names, addresses, and similar statements of people who are set up working on and living at what you want to learn and other things who need someone like you just to have more people around or to help out somehow. Maybe there's a way you can help to find people in your area who would like to have kids come to learn with them and can talk them into getting listed, or maybe you already know someone to do it with yourself. Tell your friends about the program tell everyone. The more people listed the better the program's chances. We're not meaning a program with a lot of fixed hours and schedules and contracts, just learning by being around and working at the thing you're interested in. When you see a listing that interests you write them and set up the apprenticeship—talking it out first in as much detail as you or your parents want. The apprenticeship family covers living expenses and your family travelling and extras. When you want to learn something else you move on. Being away from home will help you beat truancy. When you or your parents want, credit, transcripts, and a diploma at the right time (and a covering school address) are available through Pacific High School, Box 311, Palo Alto, Calif. 94302 by filling out the application form for their Apprenticeship Service Program and returning it. Tuition for the year would be \$200.00. In cases of need reductions right down to nothing would be available. You would need to write a short report about twice a year, and the person you're living and learning with would write one a year. You'd get credit for the time spent, your experience being translated if necessary into an understandable (by the establishment) course title. If you are 17 or more when you leave the program P.H.S. will grant a diploma. Transcripts can be sent out for the time spent even if you don't graduate. But anyone can join the Apprenticeship Program by listing in *Traveler's Directory* without going through Pacific High School when credit isn't wanted.

If you are out of your teens, no matter how far out, and you have skills or learning you'd like to communicate, rescue a teenager from the system and be your own alternative to compulsory education by sharing your home, your trade or art or craft or knowledge about something, or skill or whatever you're really involved in and good doing with them. Somebody somewhere wants to learn everything there is to learn anywhere. Get listed in *Traveler's Directory* as an Apprenticeship family or individual. Be really clear in your statement about what you would expect in the way of help or behavior, or not expect, to avoid disappointment. If enough of you do it, take the trouble (and the help) and the expense of covering your apprentices room and board, we will force the establishment schools to make themselves a better place to be. Do whatever you can to spread this information. If you are not interested maybe you know someone who would be. Help us help it work.

Write to: TRAVELERS' DIRECTORY  
Editor Peter Kacalanos  
51-02 — 39th Ave.  
Woodside, N.Y. 11377

Lois Haas  
Upper Black Eddy, Pa.

of the 200 is the most likely best-seller, and provide that one. Select a textbook on the subject and order a gross from the publisher, then have a bookbinder split these books into 20-page units of lessons (new covers should be designed, taking care to leave space for stamping on the title and number of each "lesson"). For your promotional campaign, Dr. Frazer recommends, for example, perfumed mailings and the use of "gadgets, gimmicks, premiums, giveaways, and special formats." Then when your sales begin to level off, begin preparation of your second course.

A quick look at the advertising layouts and promotional materials of most of the correspondence schools would lead anyone to believe that large numbers of them are doing exactly what Dr. Frazer suggests. And many of them go even further—they hire salesmen who are inadequately trained and paid only a commission based on their sales, with no reimbursement for expenses. In order to make sales, these men, whether instructed by their employers or not, misrepresent the courses they sell in many ways. In other words, they tell outright lies in their presentations. (The salesman from LaSalle who called on me informed me, when I told him I worked for the *New York Times*, that "a lot of the top men there got most of their training at LaSalle. I know of one—I can't recall his name right off—who got all of his training through LaSalle." Ha.)

I could relate other examples of misrepresentation by salesmen, if you want, but I doubt you have room to run this letter as it is. You may use what I have said here any way you can. I hope I have been of some help.

Sincerely,  
Adrienne Burk  
Washington, D.C.

## Trailer Life

First, let me thank you for the Catalog. I and my friend my dog & cat are excited to a carnival in Michigan and your catalog is like a big warm letter from the whole counter-culture. My reason for writing is to share with you something of our life style that might help others.

All the families on the show have house trailers and each week we set up our little village in a different (and sometimes a little hostile) place. Like fairground, behind gas stations, ball parks. For this one needs a truck to pull trailer (or heavy car), lots of hoses and electric cords, "Y's" (an object shaped [like a Y] used to connect untold numbers of trailers to the same water hookup.), a shovel to dig a hole if you don't have a self-contained bathroom.

We have a 27 foot 1957 trailer that has been our year-round home for over a year and it's just like an apartment but better. It needed a paint job so we all got stoned and did it pink, yellow, and orange. And I've got the outdoors all around.

It cost \$900 and the only money that we had to spend was for travel, i.e. hitch \$200, tires \$100. The rest has gone for rugs, sound systems, posters orange light bulbs and lots of contact. But it's a home and it's beautiful. The new trailers are more expensive (\$3,000 & up for one our size) and very sterile.

I don't know about California but the Mid West is full of old trailers & so is Florida. The old folks in the retirement parks trade in sometimes. The only drawback is our neighbors. Carnival people are a sub-culture but not ours. Trailer parks are full of nice middle class folks. But if a group of friendly freaks decided to get back to nature, I think a trailer is easier for the city folks than building a log cabin.

Susan Sullivan  
Flushing, N.Y.

## Homemade Harps

Gents,  
I was told—by a friend at Stanford Research, that you folks might be interested in my business.

Frankly it isn't much—but I sure like it.  
Robinson



THE IRISH HARP

### Specifications:

Height 40 inches  
Width 12 inches  
Weight 13 pounds

30 strings from G above treble clef to F below bass clef.

Price includes stand with 12-14-16 inch legs, and tuning key.

Price . . . . . \$398.00

## ROBINSON'S HARP SHOP

P.O. BOX 141  
MOUNT LAGUNA, CALIFORNIA 92048

## Vermont

Catalog readers seriously interested in rural living, but still concerned about political change (which seems pretty much urban-oriented) might be interested in a move to Vermont idea being promoted by some New York people. By encouraging us of the "alternative society" to establish residence in Vermont, their hope is to create new & constructive energy in that state's political machinery. And from there, who knows? I wrote to them for info and if useful, I'll send it on.

Their address:

The Society for a New America  
14 Margaret Street  
Saranac Lake, New York 12983

Robert Malone,  
East Haven, Ct.

## Appalachian Mountain Club

The west coast has the Sierra Club, the east coast has the *Appalachian Mountain Club*. A.M.C. is behind Sierra Club in style (book-wise) and effort (conservation-wise) but is rapidly trying to close the gap in those departments. A.M.C., however, has been around long enough (1878) to have compiled a large collection of available books on canoeing & climbing, plus definitive guidebooks to all northeast mountains & ranges, their trails and level of difficulty, etc.

A.M.C.  
5 Joy Street  
Boston, Mass.

Steve Bradley  
Boston, Mass.

## This & That

I was shocked to see on p. 38 of the July Catalog the U. of Indiana list of "Safe" pesticides—flea collars and shell No Pest Strips! Shame! Flea Collars carry warnings that if your pet develops a rash or your child gets a rash from petting the animal "use should be discontinued." There is a reason for this warning: Flea collars are treated with vapona which is what also permeates no-pest strips. Federation of Homemakers puts out literature on how awful No Pest Strips are. Every test ever done (except, oddly enough, a test run by Shell scientists) proved that vapona left nasty residues on food, people, etc.

About "Down on Singer" in July Catalog. Why buy a "Touch 'n Sew" anyway? We bought an 1881 treadle for \$7.50 at Goodwill and with lots of work it works fine and looks super. If you're willing to provide the power, an old treadle is a dream—and you can figure that if it's been around 90 years it'll last a few more. And Singer has parts for old machines—I even got a zipper foot for mine.

Let me put in a plug for "Sure-Jell." FREE in every package are recipes for turning anything into jam or jelly. Foolproof.

Oh! Very important. In Sept. edition of Organic Gardening, Euell Gibbons makes a really intelligent suggestion on a way to curb the Phosphate Pollution Problem. Phosphates are bad because they cause algae to proliferate like mad. We want plants on the land not in the rivers, so: Dump the phosphates in strip mines, on ravaged land, etc. where you want plants. Beautiful.

Joyce & Richard Hamilton  
Copperas Cove, Texas



## Saving the Soil

**EVERYTHING'S COMING UP ROSES IN THE STRIP MINE SPOIL BANKS:** The evidence mounts that waste water and sludge from sewage treated in municipal sanitation plants belongs on the soil instead of in the rivers and streams. Penn State Prof. William Sopper is in his second year of experimenting with treated waste as a liquid fertilizer for the most unpromising of soil types—the earth scraped aside by strip mines to expose veins of coal or minerals. Last summer, Dr. Sopper dumped 250 tons of this "spoil bank" stuff into ten large wooden planters, each 321" by 4" and holding 25 tons each. He planted grasses and tree seedlings in all boxes—but sprayed only eight of them regularly with sludge in varying proportions. By summer's end, sprayed trees and grasses had germinated and were doing beautifully. The other two boxes? Blotto. "We had 100% mortality of all species of plants," says Dr. Sopper. "Nothing survived—no trees, no grasses, not even a weed."

The implications are wondrous. Throughout the strip-mining areas of such states as Pennsylvania, West Virginia, Kentucky and Tennessee, there exists an estimated 3 million acres of spoil banks. And two-thirds of them haven't been acceptably revegetated.

*Environment Monthly*, 7/70



## Whale Songs

Attention to those of you with access to a good stereo. CRM Publications (*Psychology Today*) puts out a record of *Songs of the Humpback Whale*. Trust me that no one I've ever played it for has failed to be awed by it. These beasts have a fantastic range—you really need a good system to pick it all up. Sound travels much farther under water than through the air. This makes for some nearly unbelievable echo effects from the ocean floor. The "space" to the sound is truly awesome.

The record comes with a really good book on whales and their music. Also a lot of information on how man is killing them off. The rather high price for this record is mostly a contribution to The New York Zoological Society Whale Fund which is devoted solely to the study and preservation of whales.

I grant you that this whole thing sounds pretty strange. But its like listening to beings from another planet. Quite a trip and quite worth the money.

Peace and Love,  
Eric Johnson  
Green Bay, Wisc.

## The Humpback Whale

\$9.95

from  
CRM Publications  
Whales  
Box 131  
Del Mar, California 92014  
(New York and California residents add sales tax)

## Money, Honey

Your comments about a depression further stimulated my thinking organ. Nearly every financial analyst who correctly called the 68-69-70 stock market slump and associated phenomena now predicts a major depression, coupled with a runaway inflation and eventual devaluation of our now worthless dollar. Variations on the theme are that an increasingly intense cycle of "regression/inflation" will precede the deluge. It is also universally agreed that the best hedge against said deluge is 1. savings account in a Swiss bank in Swiss francs (more than 80% gold backed, if the dollar is devalued you will earn much, much more than the 5-6% they pay on savings); 2. silver coins (for cash you can buy coins in \$1000 bags or less from Deane S. Jones, PO Box 8414, Reno, Nevada 89507), preferably in dimes and quarters (circulated) for which you will have to pay a premium over face value because the silver content is worth more than the face price. 3. leveraged silver coins, if you have a bit more to invest, the Pacific Coin Exchange, 3520 Long Beach Blvd., Long Beach, California 90807, will loan you \$1100 on each \$1000 bag of coins and charge you 9% interest. This means you can leverage your own \$1000 up to about \$5000 and risk only the premium (about \$250) and interest. This risk is almost nonexistent—except that it is not at all unthinkable that the USFeds will make ownership of silver illegal as they did gold in 1933. You'd get your money back anyway. It is possible to buy silver, leveraged, through a Swiss Bank and Economic Research Counselors, Box 368, San Diego, Ca., 92112 are specialists in helping you do this.

If you buy silver coins as a hedge against the deluge (anyone will take a good hard silver coin) it will be best to store them in a safe deposit company, NOT IN A BANK. Bank Holidays close the whole bank, and when silver is called in, goodbye! Or you can dig a hole in the ground. The lowest prediction for the price of silver (which sold for \$1.78 and ounce at the close of the market the end of July) is \$3.00 by the end of '71. Many factors make other predictions much, much higher.

The important thing is that WHEN (not IF) the public finally loses all confidence in its politicians and their funny paper money, dimes will spend. You must have pre 1965 coins or you will get funny copper/nickle tokens called money.

At \$1.80 an ounce your coins are worth 34% more than face value; at \$3.00 an ounce they are worth 121% face value.

If you have a lot of bread, and want a more easily stored and stable piece of wealth you can buy British Sovereigns (pre 1933) from Jones. Today they will cost you about \$10.50 each or about \$44 an ounce, which is an excellent buy. They could be used as a source of land purchase, etc., or to trade for more respectable silver. Many might think these little anxieties are the mark of old fashioned reactionary nuts; however,

1. the government always degrades money
2. politicians always lie
3. people always accept silver and gold which can be tested easily for its integrity
4. nobody has found a politician integrity test yet.

Silver and gold have become good buys because the USFeds have given all theirs away and can no longer depress the market.

Cheers,  
George von Hilsheimer, himself

PS. Unless your crystal ball really works stay out of the silver commodity futures market. Only about 1% of contracts are delivered on, which means the futures games is a legal way to play craps.



## Ah, the Army

I am presently serving in the United States Army (Signal Corps) and would like to say that it (or rather certain schools it offers) is certainly relevant to independent education, your own personal feelings on militarism notwithstanding. It of course offers fine schools in electronics, diving and living off the land. If it wasn't for the war I would most probably apply for airborne training, officer candidate school and Ranger school. However, things being as they are in Vietnam, I can't see myself being a platoon leader in a Long Range Reconnaissance outfit. The thought of it scares me shitless, to be perfectly frank. I know Mr. Brand or someone who writes reviews was an airborne ranger, no offense intended.

I have the greatest respect for anyone who goes through just ranger school, I would look on someone with combat experience as a Ranger with fascination and awe.

Someone should probably review Vietnam, it is useful as a tool, since it is a medium where you can get stereo, and camera equipment, jewelry, clothes, women and VD rather cheaply.

John H. Kirck  
Glenholden, Pa.

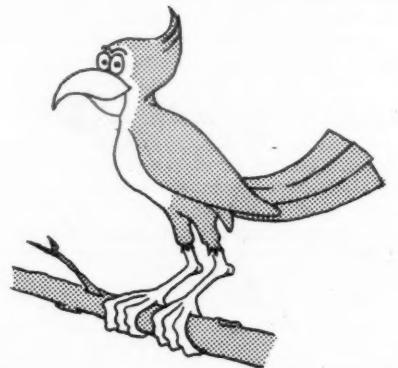

## Composter in the Sky

My wife & I recently moved to Ben Lomond from Atlanta & are unaccustomed to trash & garbage disposal problems, although we had some difficulties in Atlanta. We've been very interested in a composter, & my wife, Sandi, believes she's found the best. It's maintenance free, accepts any food scraps—except coffee grounds, which go to the ivy, is absolutely odor-free, rather handsome & extremely convenient. It's the California Blue Jay. It's only drawback is the noise factor. My wife has tried lubricating with meat grease but that had no apparent effect.

Really, Sandi says the blue jays eat anything—she puts all the garbage on an old redwood stump on the hill in back of our cabin & the jays have it cleaned up in a few minutes. If anyone knows how to make them run silently, please let us know.

Dave & Sandi  
Ben Lomond

## Shine With Soda

If you're looking for a good alternative to bleaches, try Arm & Hammer Washing Soda. We've even washed diapers in it, and they came out cleaner than with chlorine bleach.

There was a sticker on the box implying that it renders detergents ecologically sound, but when it says to use it with soap, it means just that. Detergents are pollutants.

Until Whenever,  
The Collective Consciousness  
of Happy Hollow  
Menlo Park, Ca.  
Planet Earth

## Reflections, Post-Liferaft Earth

Dear Stu,  
By happenstance I signed on #1 at the Hayward Liferaft, but in my shy way retreated to near invisibility the rest of the week (the printed account was, I think, referring to me when it said "... then there was the guy who looked like the vice-president of an electronics firm who nobody knows anything about...") I sort of did surface again momentarily the crowded night in back of the store for a probably incoherent stab at welcoming the Hog Farm bunch and the interesting new realism the experiment had taken. Anyhow, the letter doesn't depend all that much on your remembering me.

Partly, I'm sure, influenced by the Liferaft Earth experience I've been trying to only minimally support the establishment. I hope not out of just half-ass involvement, but from not having been convinced the whole structure needs toppling... I'm encouraged thinking about the kids I see today moving into responsibility. Anyhow, I make slightly less \$ than pays for food, rent and keeping the old VW running. The resulting leisure is spent, mostly at nearby isolated Land's End Beach sort of trying to coax my UCLA engineering/physics training to yield productive integrations of (e.g.)

\*Liferaft Earth Experience.

\*Seeming coalescence of humans into cities, and then further into communes, rather than the suburbanization (helicopter commutes etc.) which was predicted not too long ago.

\*Some western (probably mathematical) adaptation of the I Ching and application to simplify computer operation (One arrangement, the King Wan, as I recall, is in numerical ascending sequence when the six divided/undivided lines of the hexagrams are converted to the yes/no of binary numbers.)

\*Experiments back east searching for traces of postulated particles with velocity exceeding that of light.

\*Experiments down the peninsula with electroencephalograph response of plants to whatever human anger broadcasts.

No great flashes of inspiration, but a kind of pleasurable sense of working at what man does best, at or near my best, ensues so far. Perhaps this sort of alert but unworried intellectuation is part of what you've been fostering in your past few years. If so, many thanks.

Sorry to get so chatty, hope this finds you with leisure.

Dick Duncan  
San Francisco, Ca.

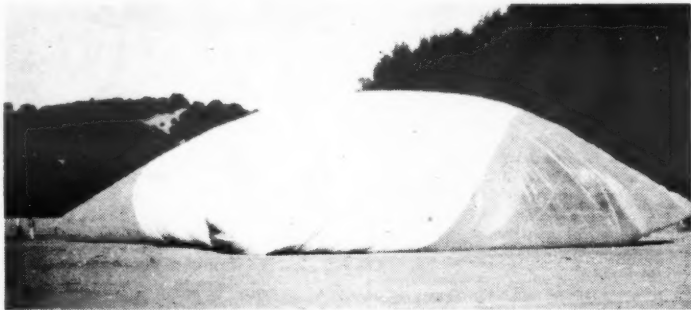

Inflated pillow designed by Tilford for Liferaft Earth.

## The Latest Inflatables

Here's what we've been doing with inflatables recently—at the Media Conference at Goddard, many of us (Cosmic Labs, Southcoast) lived in poly bubbles in the woods (300' extension cord) and stayed dry through three days of rain. Very functional and nice.

I've been doing a series of Water-Bubbles for the NYC Parks Department. Their Festival Truck goes to street fairs and provides stages, PA, lites, and Bubbles. We lay down the red carpet (non-woven polypropylene, \$1.75/sq. yd. from Ozite Corp.), inflate zoomy 16 gauge vinyl bubbles with 5000 CFM blower mounted on the truck, tie the anchor ropes to parking meters, lite poles, fire hydrants, etc., attach 1" hose to fire hydrant & 3-way distribution system: one to overhead sprinkler hoses, one to floor sprinkler hoses, one to 4-way direct spray. Add 150 kazoos, cowbells, claves, tambourines—and turn the kids loose inside. They really give it a workout—the carpet protects the bubbles and the kids when they slide and fall. I try to get them involved in putting it up and down. Some do, some don't. The first model was in 8 gauge vinyl—it almost worked, but would usually rip after a few hours. I really hate to tell them "Don't...". I think the new model will take about anything except knives. Even in Hunt's Point and Lower East Side, no knives attacked it.

Now we're in Columbia Maryland working on the Antioch project to put this campus in a 1-acre inflatable using the Goodyear system—12 gauge vinyl reinforced with steel cables with internal drainage points. The site slopes 15%. We'll do earthwork—direct ramming and CINVA Ram—to form an earth berm and interior spaces. Probably also have foamed interior structures. Southcoast is here working on a prototype. Some hassles on zoning, air conditioning, financing—we're working on a grant from Educational Facilities Labs,

## Re: Quick Hard Summary

We have started a store here in Briceland about the same time Mick (who is an old friend) did. We had an initial capital investment of about \$300. With the help of our favorite organic food store (Briceland Store) we have converted an 6'x15' space into a Whole Earth Store. Our overhead is low. Since it is a family operation no salaries are paid. Every week we deposit our money in the bank and then proceed to re-order on the past weeks revenue. Since we live in the country, we give all patrons a 10% discount on most books. As we grow we intend to lower our prices more. We are now getting into tips and also sell much handcraft items. (We get 20% of selling price) Business is booming.

So we bought a lot in town for low down and small monthly payments. We are now in process of tearing down the existing building preparatory to erecting a 40' ferro concrete dome. We need more space very badly. I figure the cost of erecting our first dome to be about \$2000 over the period of about 3 months. We are looking for spare capital but expect everything to be O.K. By the time the rains come.

Can we tell you more?

Love,  
Mike L. Limon  
Redway, Calif. 95560

## For Scroungers

I run a homestead and a small print shop. (I have a journalism degree, formerly worked as a newspaper reporter, then magazine writer.) Here are a few items I've run across that might be of interest or use.

Offset printing plants discard large numbers of printing plates. These vary in size and thickness, but they're good for roofing, feed pans, and just about anything else you'd use thin sheet metal for. Some of the schnooks are starting to charge for them, but most are free.

Wooden skids are also available many places. The largest printing plant in this area burns theirs. Even with my small shop, I've accumulated enough for a variety of uses.

I don't know about real logging country, but here where small saw-mills cut an occasional log for farmers, the slabs trimmed off to square up the log are burned. I trimmed the edges, nailed them vertically to 2 x 4's, and built a darn nice hen house and a decorative fence.

Peace.  
J.D. Belanger  
Marshall, Wisconsin

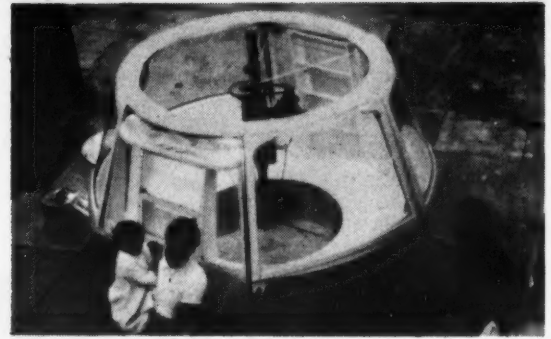

## Let The Sun Shine In

The Mobile Solar Shop and Living Unit was designed to compact all of man's material needs in the smallest possible space. (A patent has been applied for).

It is a spherical trailer with the capacity to float, made of plywood, metal and plastic. Sites for stove, sink, refrigerator, etc. have been carefully planned out to keep it compact.

A pole up the center holds the table machinery and solar power installation (now under construction). I plan to harness solar energy with a five-foot diameter aluminum parabolic concave mirror which would focus on a vacuum tube thermionic converter which will convert the heat into electricity. It is my hope that it will drive a small motor which turns the basic machine tool plus other utilities. A back up system with batteries and fuel should operate the unit during dark hours. The machine, centrally located, if supplied with small basic attachments, can perform the functions of a lathe, drill press, milling machine, radial arm saw, grinders, sanders, saber saw, sewing machine, etc. Coupled with a portable drill, hand tools, and some nuts and bolts, I feel that this basic design will allow the user to make repairs and build other tools and parts to the point where the user could be more sufficient.

With basic parts such as those that make up the unit, industry could mass produce much cheaper and faster. Today we have too many specialized and badly designed parts, tools, appliances and houses. Too many different machines have to be made to build the parts of all the millions of different products on the market today. I feel that the basic architecture of the Mobile Solar Shop and Living Unit offers a possible solution to many of the world's problems.

Back to the basic necessities; by lowering the table, the whole unit can transform into a sleeping area. Many changes are foreseen on future units which are yet to be built.

Eric Reiter  
301 16th Avenue  
San Francisco, CA 94118

## New NASA Photos

The U.S. Government Printing Office has available, at very low cost, several rather good sets of photographs from the Apollo flights. NASA Picture Set No. 1 consists of seven color prints, 11"x14", from the Apollo 8, 9, and 10 flights, at \$1.25. NASA Picture Set No. 4 contains twelve color prints of the Apollo 11 lunar landing, including an incredibly beautiful Whole Earth, at \$1.75. NASA Picture Set No. 5, at only \$1.00, has one fine color print, 16"x20", showing an astronaut standing near the lunar seismometer, with his spacecraft behind him. NASA Picture Set No. 6 is made up of ten color and black-and-white prints of the Apollo 12 lunar landing, at \$1.50. At last inquiry (June), Mariner 6 and 7 photographs of Mars were not yet available.

All can be obtained by mail from the Superintendent of Documents, Government Printing Office, Washington, D.C., 20402, or the USGPO Bookstores in some large cities. Pick them up yourself if you can: the U.S. Mail does not treat them gently. Peace.

Alan R. Betz  
Vancouver, B.C.

## Plastic Possibility

For several years we have used a tough inexpensive plastic sheet for tent flies and small tents. A nylon mesh embedded between two sheets gives this material a tear strength of 100 lbs., more than enough for such use. The manufacturer will cut the material, finish the edges and install grommets to the customers specifications. Cost is about 5 cents per square foot and grommets are about 25 cents each. Custom fabrication of tents, air houses, etc. is also available.

I think that this material would be of interest to your readers. In addition to its use in tents and tent flies I think that it would be a very practical material for use in more sophisticated tensile structures.

The manufacturer is:  
Griffolyn Company Inc.  
P.O. Box 33248  
Houston, Texas, 77033

William W. Wood Jr.  
Dover, New Jersey

(Ford Foundation). Project has a fairly high reality-feel about it. I'm working on getting the vinyl metallized—to cut down head gain. Maybe put silver mylar on the vinyl. The structure will have a double skin for insulation. This makes some problems on duct connections. But it opens up the possibility of sculpting the "ceiling" at will by varying the skin spacing. Goodyear is opening up their research department to us. The whole thing is an order of magnitude of complexity higher than the poly bubbles. But it's still more and better for less.

FINE tape source:

Arista Custom Tapes  
Foot of Farm Road  
Secaucus, N.J.  
Phone 201 864-3131

Mr. Zymler has been most cooperative and friendly. The tape we usually buy is 5 mil vinyl, \$1.20 per inch of width for 36 yard rolls, in many colors, all good (red, yellow, blue, green, white, black, orange, and others) in case lots. He'll sell as few rolls as you need—15% more for less than a case—fast service—2 days by UPS in NYC area, and ships by air. The tape can be cut in any width. I've been ordering 3" and taping both sides, for heavy-use stuff.

A source for screw-in earth anchors:

A.B. Chance Co.  
Jersey Avenue  
New Brunswick, N.J.

\$6.15 for an 8" helix on 1" x 60" shaft, will hold 10,000 lbs. in normal soil.

Charlie Tilford  
Inflatoenvironmentologist

# Alaska



## Notes from Alaska

In one of the catalogs I noticed a plea for information about land in Alaska, and I will try to put it briefly. There have been no homesteads since 1966, and won't be any until the Native Land Claims to Alaska are settled. This may be this year. It is supposed to be done this year. But then there is another bill up to Congress to extend the freeze another five years, pending an "investigation" of Alaska with a view toward conservation and leaving it wild. I am not sure how this came to be everybody else's business besides the Alaskans, but it must be because so much of Alaska is still Federal Lands.

However, there are things going on. One can buy land privately from individuals who may or may not be speculators. One can buy and lease land from the State. We are going up to Palmer in a couple of weeks and bid on five acres of wilderness. The minimum the state wants for this five acres is \$675.00. One hears about these land auctions through a publication called Alaska Land Lines, which is published by the State Department of Lands, and sent only to Alaskan addresses. Some of their land goes by lease. You can have it five years and then another five, and then if you want to own it you have to hire a surveyor. This is expensive.

Also, there are mineral lands to be had from the U.S., but again you have to have proof of "color", that there are minerals, before they let you use it. You never own these, and you have to go in yearly and do \$100.00 worth of work on your claims (I think that is right. It has been a long time since I took the course at Community College).

Alaska is 500 miles from north to south, and 1500 from east to west. There are parts of it that have not been surveyed, or even walked on. Alaska is not for an "effete snob". If you can't face realities you couldn't stand to live here. Because the realities are harsh. We have bears, and each year the magistrates go into the bear caves looking for buttons, to declare so-and-so dead. We have had 40 sightings of bears in and around Anchorage this year so far. I am scared of bears. We have horrible weather in the winter. Sometimes. The winters are sometimes cold and long—always long, and sometimes cold. I remember one winter when it stayed less than 30 below for 3 weeks straight. I made the mistake of turning the car handle with a bare hand. Now each winter the palm of my hand hurts where it was frostbit. We lose people to the elements. There was a guy—a GI—here three weeks at Fort Richardson a couple of years ago. He went for a little hike and got lost. He died less than 100 yards from the entrance to the Fort. They called it exposure, but it was just plain fright, from being lost in the wilderness. I knew a guy that goes on rescue missions. He says all the people he has rescued are out of their heads from fright by the time he finds them—that is, the ones who are still alive.

I have been down to the Land Office a couple of times and I see young long-haired people looking over the maps of what is available for lease or purchase from the State, and I am glad to see this. In spite of the putdown of young people that is going on in some places—and some places there, too—I hope they can winter through. It has always been a saying that if you could live here a year you could stay and would stay. It is possible to live off the land yet, but takes planning and the knowhow.

Peacefully yours,  
B. Duffy  
3903 Greenland Dr.  
Anchorage, Alaska 99503

P.S. If you decide to put this in the Catalog or supplement, please also do me the favor of indicating that I am interested in getting organic items (food) to sell up here, also hip mod items, and underground books and press. This isn't exactly anything that I can find here, and there is no wholesaler closer than 5,000 miles or so to me. HELP!!!

When I stopped into the store in November and dropped off the names and addresses of agencies in Alaska who dealt in land I guess I should have qualified the information. All Federal Land in Alaska is under a freeze until the Native Land Claims (or April 1, 1971 which ever comes first) are settled. Congress seems to be dealing with the claims the same way they have since the turn of the century so the freeze may be dropped and the claims not settled. At any rate Federal lands may be available for filing under the Homestead Act as of April 1, 1971.

The State of Alaska, however, does have land available now. One plan allows any citizen of the U.S. to file on 5 acres of land in one of about five areas of the state. This land is available for lease and sale. The lease runs for five years and is renewable for an additional five. At any time the lease holder can have the land surveyed and buy it at a price equal to the appraised value at the original time of filing. Other state lands are available for lease and sale from time to time. The whole state land situation can be discovered by subscribing to *Alaska Land Lines*, Write to Alaska Department of Natural Resources, Div. of Lands, 323 E. 4th Ave., Anchorage, Alaska, 99501. (Ed. Note: See below also)

Any people who come to Alaska to try to live off the land should take into consideration that everything here costs more. Fairbanks food prices run about 50% more than in Seattle. Operating a vehicle is a major strain, gas costs 55 to 58 cents a gallon etc. etc. But there are ways to make it if it's worth it. Don't expect it to be at all easy though and jobs are scarce. And there are those people here who have decided that what is wrong with America is evidenced by strange looking people who obviously are all part of a "Commie Plot". Fortunately there are not too many of them though, and Alaska is big enough so anybody who looks or acts different can mostly avoid these defenders of the faith.

In spite of the difficulties of land and existence in Alaska if one is still interested you might subscribe to Alaska magazine. Write to Alaska Northwest Publishing Co., Box 4-EEE, Anchorage, Alaska 99503. Alaska Magazine devotes some space to hunting and fishing and if you are turned off by this too bad since many Alaskans hunt-to-live and are angered by the live-to-hunt types. The magazine has lots of helpful articles.

If I have opened any questions—write.

Merritt R. Hefferich  
College, Alaska



## AUSTRALIA & IMMIGRATION

SYDNEY, Australia, Aug. 1—Australia's immigration policy which has brought in more than 2.5 million new settlers since World War II, is under attack by economists and social scientists, and the Government announced plans this week for an extensive review of the program.

The immigrants who have entered the country since 1945, mostly from Britain and Europe, make up about one-fifth of the nation's population. Economists and social scientists are asking whether it is profitable to continue the massive influx—184,000 in the fiscal year ended June 30—in view of the pressures created on schools and other social services by the arriving families.

The immigration program has also been criticized as "racist" because of the emphasis on attracting whites to keep Australia "homogeneous," as officials say. But others have expressed concern over the dilution of the predominantly white population by the admission of more than 10,000 Asians to citizenship by naturalization since the total racial bars were lowered in 1956.

Many Australians have been disturbed by the tendency of postwar immigrants to concentrate among others of the same nationality. This tendency has created constantly growing enclaves of Greeks, Italians, Yugoslavs, Maltese and others living conspicuously apart from the intermingled English, Welsh Irish and Scottish people who constitute the bulk of the population.

There is no indication, however, that the impending study will alter the present policy of admitting only nonwhites who possess needed skills and indicate capacity to integrate easily with the rest of the population.

—By Robert Trumbull, N.Y. Times

## Juicy Item

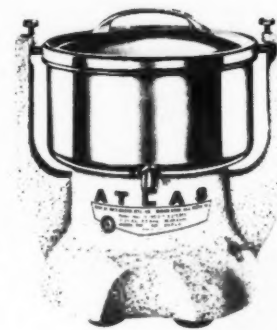

### Atlas Juicer

**\$149.95**

(Princess model **\$99.95**)

from  
Juice Master Mfg. Co.  
604 W. Muller Road  
East Peoria, Illinois 61611

I want to inform you and hopefully through you, your readers of a top quality tool for sustenance and nourishment. I enclose descriptive material on both models manufactured by Juice Master who is a little-known firm that produces top quality farm equipment.

Either the Atlas Juicer or the Atlas Princess are far superior to any of the juicers now on the market such as Braun. The Atlas costs more but the value is there in terms of materials used (no plastic) and the construction (a 10 year guarantee on the Princess and a lifetime guarantee on the Atlas Juicer).

We now have used a Princess model for one year and find ourselves appreciating fruits and vegetables in a new and exciting way. Our diet has been improved manifold and we now savor drinks ranging from carrot and cabbage juice to grape and apples juice.

For people living together it will be a useful piece of equipment.

Note, that although the retail price is high, it is extremely fair given the quality of the item. In addition you can buy either model at a discount if Juice Master does not have a sales representative in your area. Further reductions in price are available if you qualify to become a dealer—by simply ordering three units.

B.L. Faber

## Do It!

For those who are working in factories prior to moving on as I am, there is a golden opportunity to acquire a "house." The trucks which haul material into and product out of industry are covered with big tarps during inclement weather. I found one lying around, abandoned. Now have a 30'x50' roof, which rolls up into a neat bundle on top of the VW bus. My idea is to use mast and ropes, cover with forest humus. The leaf cover shortens the life of the canvas, but is nice to live in while it lasts (mold attacks with singularity of purpose a friend tells me). For those who have entertained dreams since childhood of living *The Wind in the Willows*, just go ahead; I tried rationalizing around for one year, and got nowhere. Earn some dust and go.

Balloon tires  
rolling through  
our forest are  
nicer  
quieter  
than  
extension internal combustion  
machines  
nicer  
still  
your  
soft feet our gentle feet  
belonged with the forest always

Reid  
Action, Ca.

## Tips

My wife & I stumbled upon some shoes that have decreased our stumbling in the boondocks (where did that word originate?). They're called jobmasters, made in Spain, ankle high, lace up, rough-out leather with a cleated rubber sole bonded to the uppers. They're comfortable, waterproof, & you can almost climb up the sides of buildings. Best yet—\$6.99. Available in Santa Cruz at Peninsula Surplus on Pacific Ave. & in N.Y.C. somewhere on the lower east side for a dollar less.

A hi-fi tip, or two, or three.

Not cheap, but absolutely unbeatable—any MacIntosh Gear. It all comes with a lifetime guarantee.

Much cheaper & just as good—used MacIntosh (NOT MAC) gear, if you can find it. Many sound freaks trade in tube-type Mac stuff for solid state & you can pick up some good buys.

Also, Mac has amplifier clinics (once a year—check for dates) at most stores that sell their equipment—and they'll check out any amp or pre-amp at no charge.

I concur with the Dyna Admirers. Excellent equipment.

David Brown  
Ben Lomond, Ca.



## Knives

In March 1970 Catalog I noted the mention of Custom Knife maker.

As with all things there are those who demand the "best" and for these "users" or "taste" at any price buffs there is a fine selection. The post war success of "Randal" of Florida brought on dozens of Custom Knife Makers a few of whom I shall list:

Arnold Made Knives  
Box 1427  
Grand Prairie, Texas  
75050

Clyde Fischer  
Rt. 1 Box 170  
Victoria, Texas, 77901

Buck Knives, Inc.  
6588 Federal Blvd.  
San Diego, Calif. 92114  
(Sporting gds' stores)

Dennis F. Foreman  
155 Ave. "U"  
Brooklyn N.Y. 11223  
(March '70 Catalog P. 14)

Morseth Sports Equ't.  
Box 406, Redmond, Wash.

Randal Knives  
Box 1988  
Orlando, Florida

Stone Knives Inc  
703 Floyd R'd  
Richardson, Texas

Ralph Bone Knife Co.  
806 Ave. "J"  
Lubbock, Texas, 79403

M.W. Sequine  
Juneau Alaska

T.M. Dowell  
139 St. Helena Pl.  
Bend, Oregon, 97701  
Draper Custom Knives  
Ephraim, Utah 84627  
D.E. Henry  
300 St. Henry Dr.  
Fremont, Calif. 94538  
Hibben Knives  
Manti Utah 84642  
W.G. Moran Jr.  
Rt. 5  
Frederick Md. 21701  
Lee Olsen Knife Co.  
Howard City, Mich.  
49329  
Ruana Knife Works  
Bonner Montana 59823

Al Fry  
Perris, Ca.

## Eureka "Draw-Tite" Tents

Eureka has been making tents since 1895, and for any use other than backpacking, they are outstanding. I have owned their 2-man "alpine" for 3 years. I have lived in it for weeks at a time, in Minnesota blizzards and -40° temps., as well as howling 2 week gales on the Bering Sea Coast. It goes up fast (anywhere), is warm, dry, and reasonably priced. I have used the thermos "Pop Tent", and the draw-tite is a better tent in all respects. The recreational equip. co-op has the best prices on "draw-tites."

from:  
Eureka Tent & Awning Co.  
Binghamton, New York  
or  
Recreational Equip.  
1525 11th Ave.  
Seattle, Wash., 98122  
\$53-\$133.95

Jim Kimball,  
Aitkin, Minnesota

## Yarns

You may be interested in the following yarn manufacturers for the Whole Earth Catalog or whoever can use them.

Lilly Mills Company  
Handweaving Dept.  
Shelby, N. Carolina 28150

Conventional yarns, weaving wool, metallic yarns, macramé cord stichery yarns. Good quality! Books to order. Will send catalog & price list.

Countryside Handweavers, Inc.  
Box 1225  
Mission, Kansas 66222

Swiss goatshair, cowhair, swiss linens, Swedish rug yarns (wool). Beautiful yarns, high quality. Will send samples and prices.

Frederick J. Fawcett, Inc.  
129 South Street  
Boston, Mass. 02111

Beautiful linens, all weights, natural or dyed (the natural dyes very well). Will supply samples & prices. Very good quality.

Multiple Fabric Company  
Dudley Hill  
Bradford, 4, England

All beautiful yarns. Wool, camel hair, mohair (heavy weight) horse hair. Really fine yarns. Will send samples & prices.

Briggs & Little Woolen Mill, Ltd.  
York Mills, N.B. Canada

Weaving & knitting wools, good quality—natural wools dye very well—also may order color yarns. Will send samples & prices.

Craft Yarns of Rhode Island, Inc.  
603 Mineral Spring Ave.  
Pawtucket, Rhode Island 02862  
(Formerly Troy Yarn)

All beautiful yarns, wool & synthetic. These yarns have fantastic colors. Will send samples (25 cents each) and prices. Linens, loop mohair, mohair, etc.

Mexiskeins  
c/o Sharon Murfin  
1741 Allston Way  
Berkeley, Calif. 94703

Handmade wools—all beautiful but very expensive from this supplier. Will send sample cards & prices.

The Mannings Creative Crafts  
East Berlin, Pa. 17316

They sell seconds from other manufacturers—also have a good book list & other supplies—Will send everything you need. Good prices on yarns.

Pat Eckard  
Hickory, North Carolina



## Vegetarianism and the Things We Do Around Here

("Oh, mommy shut up . . . nothing comes to my mind . . .")

compost heap  
rabbits  
bees  
the elephant shit that I got across the creek when the circus came

I'm a vegetarian because I don't like the idea of killing animals. I think other people should be vegetarians because in one life you'll eat more than ten cows if you add up all the meat you'd eat in your lifetime and average it together and if you can save the lives of ten cows by being a vegetarian, then I think it's worthwhile to be one.

We built a house in our backyard. It's a biodegradable shack because after maybe 50 years it would fall back into the earth. It doesn't have any cement structure in it. We didn't have to buy the lumber because we just picked it up from construction jobs (after asking) and from dumps and some jobs had perfect beams. So less trees had to be cut down in the world.

There was a circus across the creek from our backyard and when the circus had gone away, I went with a big bag and collected all the elephant shit. We put it in our compost heap in the ground and it rotted away and it's great earth for plants. We put all our organic stuff in the compost heap (banana peels and things like that). The organic waste makes our plants grow better and faster and it gets rid of all our organic garbage which is half of our garbage.

Andy Forrest (age 9)

## Sailing, Sailing

For anyone interested in a cruising knowledge of boat-building, there is now in production a Tahiti ketch. It is modelled after the adios, a three-times-around-the-world traveller. For \$3800.00 you can have a hand-laminated hull of heavy fibreglass, one-piece construction with the bulkheads, the shelf, chainplates and clamps in place. It is 32 feet long with a 10 foot beam and can be ketch or cutter-rigged.

Contact:  
Dreadnought Boatworks  
Box 221  
Carpenteria, Calif. 93013

Mr. & Mrs. Michael Gazzaniga  
New York City, N.Y.

## More Good Soap

I would like everyone to know of Dutch Lady soaps.

All their products are completely Biodegradable and only one has any phosphates at all. That is the laundry detergent; which has something like 7.0% phosphates.

Their prices are very reasonable, even cheap, and considerably better than Shaklee's.

They carry everything—laundry soap (soft & hot water pump), laundry detergent (any old kind of water), hand soap, pumice soap, shampoos, creme rinse (?), fabric softener, bleach, floor wax . . . All biodegradable—phosphate-free except for above mentioned detergent. They will gladly ship anywhere if you pay.

addresses:  
Dutch Lady Soaps  
2517 Main St.  
Vancouver, B.C.

or  
1663 Bayview  
Toronto, Ontario

or  
59 Cambridge  
Toronto, Ontario

Good Luck and Right On!

Jill Wallace  
Harvard, Mass.

## The Record Man

The best consistent deal I have found for dependable record purchases at the lowest cost is the mail order service of the Wholesale Record Man. Everything is a flat 40% off, which means that a \$4.98 album is \$2.99, and a \$5.98 album is \$3.59, plus tax if you live in California. His prices are lower than any other mail order record business—even the Record Club of America, except on a few sale items—and lower than most stores. He beats the record clubs by charging a 25 cent postage and handling fee only on orders less than \$5.00, which saves a lot compared to the 35 cents per album fee of RCA. The same applies to tapes.

Most important, he's honest, and the service is as fast as any club, particularly if you're on the West Coast. All you need is artist and title, plus the necessary cash, and he'll do the rest. The address is:

Wholesale Record Man  
PO Box 48544  
Los Angeles, California 90048

Hope this is usable. The Man has always taken care of me.

Ken L. Smith  
San Francisco, Calif. 94123

# An Indian Bibliography

who loned it through the streets of Idaho seeking visionary indian angels who were visionary indian angels . . .

—Ginsberg, Howl

The booklist that follows comes from two intense informal years (and five slack ones) hanging around Indians, reservations, anthropologists, and libraries. Long may Indians, reservations, anthropologists and libraries thrive! They gave me more reliable information, and human warmth, than dope and college put together.

I'm sure that the books all by themselves cannot deliver The Native American Experience. For that you need time immersed in the land and neighborly acquaintance at least with some in fact Indians. Still, an amazing amount is in the books.

A nice broad illustrated introduction is

**The American Heritage Book of Indians**  
Alvin M. Josep, Jr.; William Brandon  
1961; 424pp.

\$16.50 postpaid

from:  
Simon and Schuster  
630 Fifth Ave.  
New York, N.Y. 10022

The account, historical rather than anthropological, is comprehensive for all the major tribes and their profound diversity. Good color pictures.

Now, if you like your Indian lore in raw handfuls of nuggets rather than gussied up into jewelry, then the twin treasures of Bureau of American Ethnology and Edward Curtis The North American Indian are worth the trouble of making friends with a large library.

## TWO TREASURES

The Annual Reports of the Bureau of American Ethnology, Smithsonian Institution are about fifty feet long on the shelf. Enormous volumes begun in the 1870's by one of Congress' benignest acts right when anthropology was quickening into life and the Indians were still there, tribal and strong. The engravings (many of them gently hand-colored), as well as the later photographs, are splendid artifacts in themselves. What the investigations yield, in minute detail, is a grab bag assortment of diamond glimpses into old tribal ways, not seen whole maybe but seen with a kind of discipline that's admirable. At one time I wanted to assemble an anthology of text and illustrations from the BAE volumes to be called "American Indian Genius". I hope someone will do it.

The following quotes and illustrations are from the 1881-82 Annual Report and Bulletin No. 186, 1963.

Smithsonian Institution  
Bureau of American Ethnology  
Anthropological Papers  
U.S. Government Printing Office  
Washington, D.C.

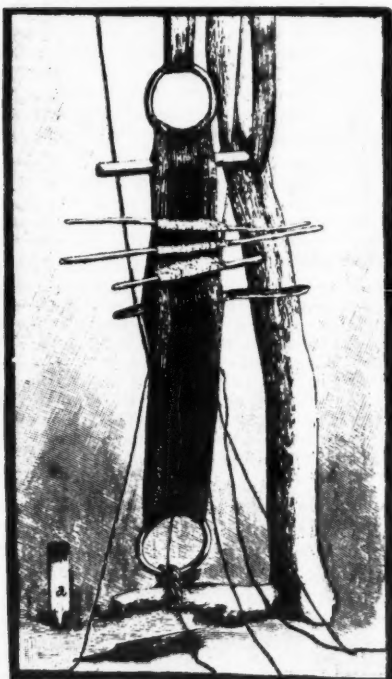

Weaving of saddle-girth.

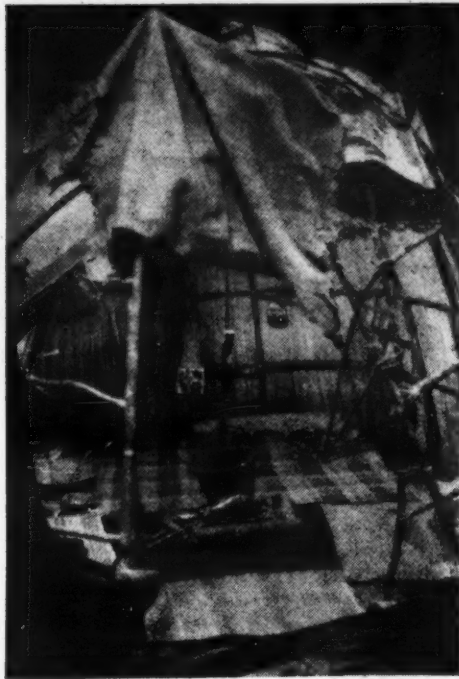

Wigwam showing mats in use. Rear and foreground floor, cedar-bark mats. At sides, rush mats. On walls, cattail mats. (Courtesy of the Science Museum, St. Paul, Minn.)

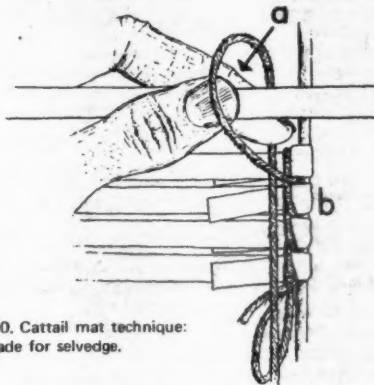

Figure 30. Cattail mat technique:  
Loop made for selvage.

1. The worker grasps a pair of leaves, concave side toward her, with the thumb and index finger of the left hand about 2 inches from the end, which is in front of her and near the hanging foundation twine.
2. With her right hand she loops the tying cord loosely around the leaves and the two fingers holding them, winding in the direction away from herself and keeping the loop open with the two fingers (fig. 30, a).
3. She places the leaves behind the foundation twine with about 1½ inches projecting on the right side of the twine.
4. She turns the ends of the leaves over the foundation twine, toward her.
5. She slips the ends under the loop, her left fingers assisting.
6. She pulls downward hard on the side of the loop away from her, to pull the ends of the leaves closely together (fig. 30 b), and ties the end of the cord in a slipknot. (This knot is not repeated in the rest of the process.)
7. She pulls the excess tying cord to the front.

140. Council and appointment of policemen.—As soon as they could see the herd they stopped. Then the crier called certain young men by name, saying, "Let us consecrate some ta or sides of buffalo meat. You will take a ta for me." (See 151.) A council was held by the chiefs and directors, and having decided to surround the herd, policemen were appointed. These wanace were selected from the wahehaji or brave men. They had no work to do till they were near the herd. Then they had to watch the people to keep them from scaring off the herd by moving before the proper time. All who disobeyed them were severely punished. Cadacice, an aged Omaha, who is now lame and palsied in one limb, was once strong and highly esteemed by his people; but he violated the rules of the hunt, and all the policemen flogged him so unmercifully that he never fully recovered from the effects of his punishment. The offense was committed when the people had been unsuccessful in finding a herd, and were almost starved. Suddenly some buffaloes were discovered. Though it was against the law for any small number of men to go against the herd, independently of the rest, two or three, including Cadacice, disobeyed, and, rushing forward, scared off the herd, so that none were caught. On another hunt, when the men were behind a bank, seven of them wished to ascend the hill sooner than Two Crows directed. They started up against his wishes; but he rushed after them and lashed them right and left with his whip, compelling them to desist.

During the council the chiefs said, "Let us consecrate some buffalo tongues, and also two or four hearts." Then, calling on two of the young men, they said, "Young men, you will get the hearts and tongues for us, and place them together at the sacred tent."

Stewart Brand  
16 September 1970

The North American Indian, Edward S. Curtis, 20 volumes, 1907-1930, is the non-stop best portrait gallery in the history of photography. The best collection of Indian images, and the most ambitious one-man one-work photographic effort ever made. You haven't heard of it because only 500 sets were printed and they cost about \$5000 apiece then. Curtis won support from J.P. Morgan for the venture of visiting all the surviving American and Alaskan tribes of his time and photographing them in traditional dress and activities. He delivered. Most of the tribes he visited, Curtis wound up joining the local medicine society to establish his seriousness. His photographs show Indians relaxed, proud, at home on their land and in their tribal life. Hundreds and hundreds of photographs, half of them huge 20"x30" sepia plates. Some 176 are reproduced in

Curtis' Western Indians  
Ralph Warren Andrews  
1962

Out of Print

I've heard rumors of plans to reprint Curtis' entire monumental work. I hope for that. (All I've got handy for illustrations are four measly captionless polaroid prints. Sorry.)





## FIVE VISIONS

**The Teachings of Don Juan**  
Carlos Castaneda  
1968; 276pp.

**\$0.95** postpaid

from:  
Ballantine Books, Inc.  
101 Fifth Avenue  
New York, N.Y. 10003

or WHOLE EARTH CATALOG

*Dope and power, or powers, is a beguiling treacherous road that the children of the Europeans are suddenly on—with ambitions often that are strange to the road. It is as if we had discovered, now, the subtle continent of America, and were proceeding once again to explore and subdue it without regard for native occupancy and native wisdom. If heeded, this book can help to allay the trespass.*

*Don Juan's way to knowledge is the loneliest and hardest I've heard of, approaching Buddha's for austerity and interior hardship. It uses drugs to plunge directly into battle with oneself, without any promise of ecstatic rewards, without even the companionship and familiar ritual of the peyote meeting. All Don Juan gives his student is challenges, paradoxes, and bone-dry advice on how to recognize what's going on and how to get further down the road into profounder difficulties.*

*In Castaneda's case, the student is as admirable to me as the teacher. His research was courageous and original; the writing is practically transparent.*

He listened without interrupting me. I talked for a long time. Then he said:

"All this is very easy to understand. Fear is the first natural enemy a man must overcome on his path to knowledge. Besides, you are curious. That evens up the score. And you will learn in spite of yourself; that's the rule."

I protested for a while longer, trying to dissuade him. But he seemed to be convinced there was nothing else I could do but learn.

"You are not thinking in the proper order," he said. "Mescalito actually played with you. That's the point to think about. Why don't you dwell on that instead of your fear?"

"Was it so unusual?"

"You are the only person I have ever seen playing with him. You are not used to this kind of life; therefore the indications [omens] bypass you. Yet you are a serious person; but your seriousness is attached to what you do, not to what goes on outside you. You dwell upon yourself too much. That's the trouble. And that produces a terrible fatigue."

Don Juan suddenly changed the direction of the conversation and bluntly confronted me with the idea that I liked the devil's weed. I had to admit that I had at least a preference for it. He asked me how I felt about his ally, the smoke, and I had to tell him that just the idea of it frightened me out of my senses.

"I have told you that to choose a path you must be free from fear and ambition. But the smoke blinds you with fear, and the devil's weed blinds you with ambition."

I argued that one needs ambition even to embark on any path, and that his statement that one had to be free from ambition did not make sense. A person has to have ambition in order to learn.

"The desire to learn is not ambition," he said. "It is our lot as men to want to know, but to seek the devil's weed is to bid for power, and that is ambition, because you are not bidding to know. Don't let the devil's weed blind you. She has hooked you already. She entices men and gives them a sense of power; she makes them feel they can do things that no ordinary man can. But that is her trap. And, the next thing, the path without a heart will turn against men and destroy them. It does not take much to die, and to seek death is to seek nothing."

### Book of the Hopi

Frank Waters, Oswald White Bear Fredericks  
1963; 423pp

**\$1.25** postpaid

from:  
Ballantine Books, Inc.  
101 Fifth Avenue  
New York, N.Y. 10003

*If you're susceptible to tarot or astrology, you'll probably revel in this book. Its business is the esoteric lore and historical drama which lives and protects the Hopi Indians in Arizona. They were possibly the farthest out of the American tribes (in present times they are not as together as Zuni, or Taos, but they are larger and so is what they attempted). This is the mysticism not of change but of stability, of the year cycle, of one more winter of food obtained by the hard knowledge from uncounted prior generations of winters and, they say, travels from world to world and place to place to arrive finally at the center, these bleak mesas, to here sustain forever responsibility for the well-being of the world. Frank Waters was perhaps too eager to write a Bible, but I can't blame him. It's that kind of knowledge.*

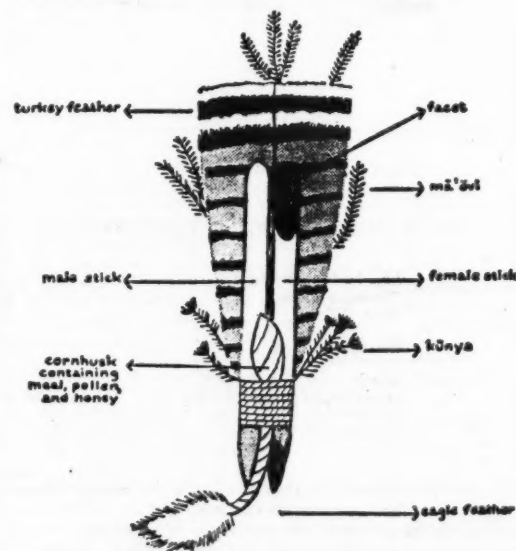

Figure 55. Male-and-female páho

Every páho, simple or complex, is made with prayerful concentration and ritually smoked over. Then it is carried to a shrine, where it is stuck in a cleft of rocks or hung on a bush and left until the invisible vibrations of the prayer it embodies are slowly absorbed by the forces of life to which it is dedicated.

So the people emerged to the Second World. Its name was Tokpa Dark Midnight. Its direction was south, its color blue, its mineral *gochasiva*, silver. Chiefs upon it were *salavi*, the spruce; *kwahu*, the eagle; and *kolichiyaw*, the skunk.

It was a big land, and the people multiplied rapidly, spreading over it to all directions, even to the other side of the world. This did not matter, for they were so close together in spirit they could see and talk to each other from the center on top of the head. Because this door was still open, they felt close to Sotuknang and they sang joyful praises to the Creator, Taiowa.

They did not have the privilege of living with the animals, though, for the animals were wild and kept apart. Being separated from the animals, the people tended to their own affairs. They built homes, then villages and trails between them. They made things with their hands and stored food like the Ant People. Then they began to trade and barter with one another.

This was when the trouble started. Everything they needed was on this Second World, but they began to want more.



Parrot Clan maiden sitting on a plaque of seeds during Soyál Ritual.

### Black Elk Speaks

John G. Neihardt (Flaming Rainbow)  
1961; 28pp.

**\$1.50** postpaid

from:  
University of Nebraska Press  
901 N. 17th Street  
Lincoln, Nebraska 68508

*The Pueblo tribes don't go in for visionary solitary mystical whizbangs. (Of all of them only Taos is into peyote very much.) The plains tribes are something else however. Their lives turned on their visions—solo manhood transports, dreams, name visions, sun dance ordeals, battle ecstasy, doctoring sessions . . . and later, ghost dance and peyote. This book is the power vision of one Oglala Sioux, and the extraordinary man it made. Black Elk's account, besides affording unusual insight into Sioux life and historical figures such as Crazy Horse, demonstrates the manner of recognizing a serious vision and being responsible for it, and the burden, joy and power of doing that.*

... Then I was standing on the highest mountain of them all, and round about beneath me was the whole hoop of the world.<sup>8</sup> And while I stood there I saw more than I can tell and I understood more than I saw; for I was seeing in a sacred manner the shapes of all things in the spirit, and the shape of all shapes as they must live together like one being. And I saw that the sacred hoop of my people was one of many hoops that made one circle, wide as daylight and as starlight, and in the center grew one mighty flowering tree to shelter all the children of one mother and one father. And I saw that it was holy.

<sup>8</sup>Black Elk said the mountain he stood upon in his vision was Harney Peak, in the Black Hills. "But anywhere is the center of the world," he added.

When a vision comes from the thunder beings of the west, it comes with terror like a thunder storm; but when the store of vision has passed, the world is greener and happier; for wherever the truth of vision comes upon the world, it is like a rain. The world, you see, is happier after the terror of the storm.

You have noticed that the truth comes into this world with two faces. One is sad with suffering, and the other laughs; but it is the same face, laughing or weeping. When people are already in despair, maybe the laughing face is better for them; and when they feel too good and are too sure of being safe, maybe the weeping face is better for them to see.

I think I have told you, but if I have not, you must have understood, that a man who has a vision is not able to use the power of it until after he has performed the vision on earth for the people to see.



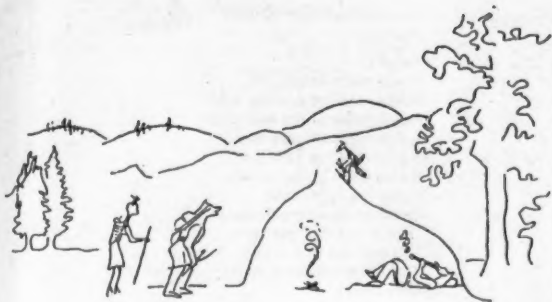

"I don't want to, I DON'T WANT TO. I don't want to be a MAN; I want to be a Fox."

"Oh, the Ha-Has again. You are reverting."

Fox was laughing. He said, "Seriously, Oriole, why did we grow up so fast? Only yesterday, when we began our story and I started to see the world with my father, who was then a real Bear..."

Oriole interrupted. "No, you are mistaken. He was not a real Bear yet, he was only a beginning of a bear, he was a person-bear. Now he is a bearman—I mean a man-bear... I mean..."

"Oh, keep quiet. You are getting me all mixed up again."

"No, Fox, listen to me; I will explain. The man who is telling our story, it's his fault, he has done something wrong with the machinery of time, he has let it go too fast. You see, he was supposed to take a million years to tell our story. The poor fellow, he is too old, he gets all mixed up. He should go and take a rest in the country for a while."

"Oh, my, my, my!" sighed the Fox, "the only thing to do is to start again RIGHT AT THE BEGINNING." Fox looked curiously at Oriole. "What do you mean, a MILLION years?"

"Why, I mean an infinity of time, just as Tsimmu was telling in his story of the creation of the world, Don't you remember? Ten times ten times ten times ten years, *molossi molossi molossi tellim piduui*. When Cocoon Man was floating around in nothing but air and fog he waited a million years for that cloud to come near enough so he could jump on it."

"Yes," said Fox. "Yes, just like Marum'da, who made the world and then he went to sleep. That's an infinity of time, but it must stop somewhere—it can't go on forever. It must stop somewhere."

Oriole asked, "WHY?"

Fox thought a moment then he said, "I dunno. But listen, Oriole, what's time anyway?"

Oriole said, "Why, it's ten times ten times ten times ten years. What else do you want it to be?"

Fox said, "I dunno, I guess it's growing old."

Oriole said, "All right, then, some people grow old faster than others. You know that yourself. Just as some people walk faster than others. It all depends on who is looking at it."

"Why, Oriole, you are crazy. It depends on who is walking, not on the man who is looking at the fellow who is walking."

"No, certainly NOT. Look at that man over there walking. He seems to be just crawling along, but if you were close to him, he would be going much faster. That's the way with the man who is telling this story. Sometimes he is closer and sometimes he is farther away, so for him that makes us go faster or slower."

Fox said, "Oriole, you drive me crazy. Now I don't know whether I am standing on my head or my feet. It's like that time when we first met you and your father."

"Listen, Fox, it is not I who started this idea that there was a man telling this story, it was you. For all we know, there is no such man."

"Of course, there is not, I invented him."

"That doesn't prove anything. Marum'da invented the people, and they existed whether he liked it or not. Maybe you invented the man who is telling this story, so now he exists. It's too bad, but now you can't get rid of him."

"Yes, I will. I'll destroy him the way Marum'da did the people."

"Then you know what will happen, Mister? You won't exist any more because he is the one who is telling the story."

"Oh, oh, oh, stop, Oriole!" Fox was holding his head in both hands. Then he laughed as he pulled Oriole to her feet and they both ran down the hill.

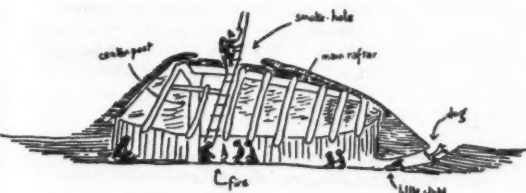

To explain a wigwag of the large conical type and partly underground

### Zuni Breadstuff

Frank Hamilton Cushing  
1920; 673 pp.

Indian Notes and Monographs, Vol VIII  
Museum of the American Indian  
Heye Foundation

Out of Print (available in large libraries;  
I was able to buy a copy through  
Woodard's Indian Arts, Gallup, N.M.)

Cushing is the classic case of the anthropologist who went native. He was sent by the Smithsonian Institution to study the Zunis in the late 1870's. By 1875 the frail genius had joined the Pueblo, was living the Zuni life entirely, and soon became a high officer. He was a totally successful and wholly foiled anthropologist. He knew all the Zuni religious secrets, but as a responsible member of the tribe he could not reveal them. His only consequential writings were a series of articles for a bread-making trade magazine called *The Millstone*; the articles, which are collected in this volume, go far beyond bread into every tellable aspect of Zuni life. In 1884 Cushing returned to the East Coast, fiddled around for a few years of failing health, and died in 1900 at the age of 43. Some anthropologists say it was because he did reveal secrets. I see the book doesn't really have the quality I remember from first reading, but it's still a phenomenon.

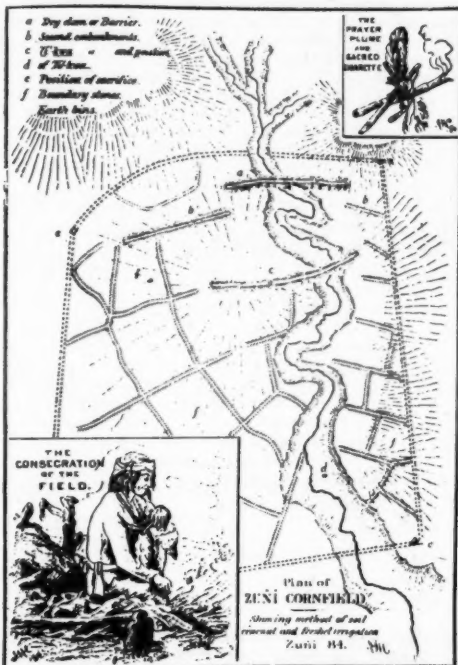

Plan of a Zuni Cornfield

After the corn was ripened, two modes of making it eatable were extremely simple. Still on the ear it was toasted, or, in the kernel, parched. In several ways this parching was accomplished. Crudest of all these was burial and constant stirring in hot ashes; but the favorite process was to half fill a *thle-mon-ne*, or black, shallow roasting pot or pan (pl. xi, d), with clean, dry sand. The pot was then set over the fire until the sand became thoroughly heated, when the corn was poured in and constantly stirred with a bundle of hard-wood sprigs (e) so loosely tied at the middle that they could be spread apart in order that the sand and corn might readily pass between them. When well browned and swollen, a judicious shaking of the toasting vessel brought all the kernels to the top, whence they were easily separated from the sand. Of the corn thus parched, a highly concentrated and nutritious substance was made, the grains first being cracked, re-toasted, and then ground to fine flour. A little of this flour stirred into cold water made a gruel which required no cooking and was capable alone of sustaining life throughout extended journeys, where lightness of burden and ease of preparation were prime requisites. Mixed with water and sweetened by a means heretofore described, or happily by the addition of ground licoriceroot, fermented and slightly boiled, it made a thin syrup or sweet gruel (*tsa-shi-we*), ever the favorite at the Zuni evening feast.

When the corn was designed for consumption without further preparation than by the parching, salt, if abundant enough, was used in place of the sand, imparting to the kernels roasted in it a delicate seasoning unattainable by the cruder methods first described.

Thus, it may be seen that one small nation is organized on four different principles, no one of which has, save in the religious aspect, dependency on any of the others: (1) The sacred government, according to the places of worship; (2) the secular government, according to landed and water possessions; (3) the medical government, according to professions of "medicines" and fetishism; and finally (4) the social government, according to family organization. Were this paper treating rather of the sociology than of the food productions of the Zunis, I could show how these four kinds of subdivisions harmonize with one another; how, indeed, the first three were the outgrowth of the fundamental social principle of the tribe, and how, finally, with the addition of the phratral combinations of clans (now modified or outgrown among the Zunis), all four features were well-nigh universal to aboriginal America.

### Hunters of the Northern Ice

Richard K. Nelson  
1969; 429pp.

\$8.50 postpaid

from:  
University of Chicago Press  
5750 Ellis Avenue  
Chicago, Ill. 60637

For anyone wanting to stay alive around ocean ice this book is necessary; otherwise it is merely fascinating. Nelson was an eskimo for the U.S. Air Force. He spent four years engaged in the seal hunters' life accumulating polar survival lore and respect for Eskimo endurance and ingenuity. His report is as dense and pungent and nourishing as good pemmican. Every sentence tells you something about ice formation, ice movement, finding open water, weather forecasting, cold injury, ice camps, bird behavior, game habits, hunting techniques... survival in terrain without margin.

One of the most definitive characteristics of safe versus unsafe is its color. Although there are intermediate shades and rare exceptions, unsafe young ice is very dark, usually black. New ice is saturated with water and is sufficiently translucent to reveal the dark color of the sea below. As the ice thickens it begins to rise higher in the water; therefore the color becomes gray (*sikuliak maptiz oak*).

Unlike the westerners with whom he has contact in modern times, the Eskimo seldom doubts what he has been told by others, especially if they are his elders. Thus, without previous actual experience in a given situation he will unquestioningly respond to it in the way that he has been told. The outsider, on the other hand, continually frustrates the Eskimos by doubting these instructions and attempting to formulate original solutions which he believes to be better. Those who live with Eskimos over a long enough period find themselves questioning less and less, and following whatever they are told to do by their more experienced native companions.



Returning to the ice apron after retrieving a seal with an *umiahakrak*. The man at the left spreads his legs wide to prevent his breaking through the thin ice. He will use the hook of his *unaak* to draw the boat up onto the ice.

There is one other attitude of the Eskimo which seems to be adapted to his economic life. This is his ability to find genuine humor in misfortunes that befall him, or in his own errors. It is sometimes explicitly stated that a hunter should laugh when things go wrong, because anger never helps him, while laughter makes him better able to overcome setbacks. In an environment where so much can go wrong, and it is so easy to lose something that has nearly been gained, such an attitude is almost a necessity. If a hunter has shot a bearded seal, and when the harpoon is tossed it glances off just as the animal sinks, this is an occasion for laughter, not for disgust. The old hunter, Kavik, never tired of telling stories of his exploits, and he would sometimes laugh until tears glistened in his eyes when he told of his greatest and most frustrating mistakes.

"Portrait of an Artist with 26 Horses"  
in 3 by Eastlake  
William Eastlake

\$4.95 postpaid

from:  
Simon & Schuster  
630 Fifth Avenue  
New York, N.Y. 10020

Ken Kesey first told me about this one. I can't lay my hands on a copy right now, so I'll review the memory and starve for quotes. Eastlake was living in the high desert "checker-board" country north of Albuquerque, in deep with Navahoos and horses and unbelievable winters. This story concerns a dying young Navaho and some of the things a Navaho takes seriously and some of the things he takes lightly. The writing has a parsimony I miss in Eastlake's later work.

Little Big Man  
Thomas Berger

\$ .95 postpaid

from:  
Fawcett Publications  
Fawcett Place  
Greenwich, Conn. 06831

Most fiction about Indians is so God damned sentimental it can cloy the whole subject for you (La Farge, Sandoz, Borland, etc. even Momaday). Berger is the only one I've read who can introduce the matter of mysterious Indian powers without sounding either worshipful or occult. Also he apparently does his homework—more than say Kesey or Mathieson—and this account of a white living with the Cheyennes around the time of Little Big Horn rings historically as well as emotionally true. Arthur Penn and Dustin Hoffman are making the movie, so you'll have an easier time finding a copy of the book than I have.

America Needs Indians!  
Iktomi  
1937; 425 pp.

Out of Print (I got a copy from Woodard's Indian Arts, Gallup, N.M.; occasional libraries have it.)

Bizarre. "Iktomi" was a white man, with a Sioux wife for a while there, who had an elaborate fantasy for saving Indians and America, and got a vanity press to print it ("He'd sit there at the typewriter with his hat on, typing last minute footnotes to his footnotes.") and then disappeared in a cloud of unpaid bills. Iktomi is the Sioux trickster figure—and for crazy self-contradiction—this book lives up to the tradition. Amid its italicized and capitalized ravings are ideas that the tribes or the Bureau maybe ought to try out. Iktomi's dream-map of an idealized recreational reservation is quite a vision (small fraction of it is reproduced here). And America does need Indians.



American Indian Prose and Poetry  
Margot Astrow  
1962; 366pp.

\$1.45 postpaid

from:  
Capricorn Books  
J.T. Putman Sons  
200 Madison Avenue  
New York, N.Y. 10016

Of the several Indian "poetry" anthologies—A. Grove Day; The Indians Book; even Technicians of the Sacred, which we carry in the CATALOG—this is my preference. The contents are second derivative of course. Songs and speeches stripped of their original music and context. Then translated from their original language. But the words were for power, and the power carries.

The outstanding feature of American Indian verse construction comes from parallel phrasing, or, let us say, repetition with an increment, which gives an effect not of rhyming sounds but of rhyming thoughts. —Herbert J. Spinden

Says the Lakota Indian Chief, Standing Bear:  
Training began with children who were taught to sit still and enjoy it. They were taught to use their organs of smell, to look when there was apparently nothing to see, and to listen intently when all seemingly was quiet. A child that cannot sit still is a half-developed child.

Love Song  
(Chippewa)  
A loon I thought it was  
But it was  
My love's  
Splashing oar.

War Song  
(Pawnee)  
Let us see, is this real,  
Let us see, is this real,  
This life I am living?  
Ye Gods, who dwell everywhere,  
Let us see, is this real,  
This life I am living?

"Guard your tongue in youth," said the old chief Wabashaw, "and in age you may mature a thought that will be of service to your people!"

One of our people having killed a Frenchman at Prairie du Chien, the British took him prisoner and said they would shoot him next day. His family were encamped a short distance below the mouth of the Wisconsin. He begged for permission to go and see them that night as he was to die the next day. They permitted him to go after he had promised them to return by sunrise the next morning. He visited his family, which consisted of his wife and six children. He cannot describe their meeting and parting so as to be understood by the whites, as it appears that their feelings are acted upon by certain rules laid down by their preachers, while ours are governed by the monitor within us. He bade his loved ones the last sad farewell and hurried across the prairie to the fort and arrived in time. The soldiers were ready and immediately marched out and shot him down.

Black Hawk  
(Sac)

Brother, we are told that you have been preaching to white people in this place; these people are our neighbors, we are acquainted with them; we will wait a little while and see what effect your preaching has upon them. If we find it does them good, makes them honest, and less disposed to cheat Indians, we will then consider again what you have said.

Red Jacket  
(Seneca)

Prayer of the Night Chant  
(Navajo)

Tseghí.  
House made of dawn.  
House made of evening light.  
House made of the dark cloud.  
House made of male rain.  
House made of dark mist.  
House made of female rain.  
House made of pollen.  
House made of grasshoppers.  
Dark cloud is at the door.  
The trail out of it is dark cloud.  
The zigzag lightning stands high upon it.  
Male deity!  
Your offering I make.  
I have prepared a smoke for you.  
Restore my feet for me.  
Restore my legs for me.  
Restore my body for me.  
Restore my mind for me.  
This very day take out your spell for me.  
Your spell remove for me.  
You have taken it away for me.  
Far off it has gone.  
Happily I recover.  
Happily my interior becomes cool.  
Happily I go forth.  
My interior feeling cool, may I walk,  
No longer sore, may I walk.  
Impervious to pain, may I walk.  
With lively feelings may I walk.  
As it used to be long ago, may I walk.  
As it used to be long ago, may I walk.  
Happily may I walk.  
Happily, with abundant dark clouds, may I walk.  
Happily, with abundant showers, may I walk.  
Happily, with abundant plants, may I walk.  
Happily, on a trail of pollen, may I walk.  
Happily may I walk.  
Being as it used to be long ago, may I walk.  
May it be beautiful before me.  
May it be beautiful behind me.  
May it be beautiful above me.  
May it be beautiful all around me.  
In beauty it is finished.

A Prayer  
(Yokuts, California)  
Do you see me!  
See me, Tuushiut!  
See me, Pamashiut!  
See me, Yuhahait!  
See me, Eshepat!  
See me, Pitsuriut!  
See me, Tsuksit!  
See me, Ukati!  
Do you all help me!  
My words are tied in one  
With the great mountains,  
With the great rocks,  
With the great trees,  
In one with my body  
And my heart.  
Do you all help me  
With supernatural power  
And you, day,  
And you, night!  
All of you see me  
One with this world.

THE WAR GOD'S HORSE SONG (Navajo)  
I am the Turquoise Woman's son.  
On top of Belted Mountain  
Beautiful horses—sím like a weasel!  
My horse has a hoof like striped agate;  
His fetlock is like a fine eagle plume;  
His legs are like quick lightning.  
My horse's body is like an eagle-plumed arrow;  
My horse has a tail like a trailing black cloud.  
I put flexible goods on my horse's back;  
The Littly Holy Wind blows through his hair.  
His mane is made of short rainbows.  
My horse's ears are made of round corn.  
My horse's eyes are made of big stars.  
My horse's head is made of mixed waters  
(From the holy waters—he never knows thirst).  
My horse's teeth are made of white shell.  
The long rainbow is in his mouth for a bridle,  
And with it I guide him.  
When my horse neighs, different-colored horses follow.  
When my horse neighs, different-colored sheep follow.  
I am wealthy, because of him.  
Before me peaceful,  
Behind me peaceful,  
Under me peaceful,  
Over me peaceful,  
All around me peaceful—  
Peaceful voice when he neighs.  
I am Everlasting and Peaceful.  
I stand for my horse.

Song To Bring Fair Weather  
(Nootka)  
You, whose day it is, make it beautiful.  
Get out your rainbow colors,  
So it will be beautiful.

Plaint Against The Fog  
(Nootka)  
Don't you ever,  
You up in the sky,  
Don't you ever get tired  
Of having the clouds between you and us?

(Peruvian Dance Song  
(Ayacucho)  
Wake up, woman,  
Rise up, woman,  
In the middle of the street  
A dog howls.  
May the death arrive,  
May the dance arrive,  
Comes the dance  
You must dance,  
Comes the death  
You can't help it!  
Ah! what a chill,  
Ah! what a wind . . .

**The Bark Canoes and  
Skin Boats of North America**  
Edwin Tappan Adney, Howard I. Chappelle  
Smithsonian Institution, USNM Bulletin No. 230  
**\$3.25** postpaid  
from:  
Government Printing Office  
Washington, D.C.

Design and construction details for all native American  
boats. Complete.

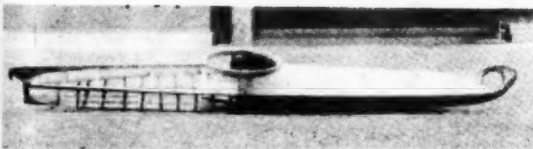

Nunivak Island Kayak in U.S. National Museum (USNM 76283) with cover partly removed to show framework. Collected by Ivan Petroff, March 30, 1894.

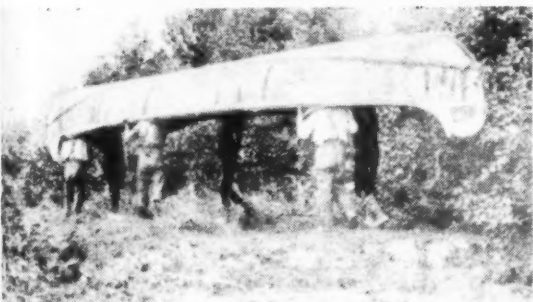
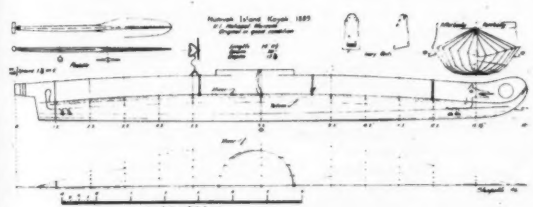

Portaging a 4½-fathom fur-trade canoe, about 1902, near the head of the Ottawa River. Shows an unusually large number of carriers; four would be the normal number.

**TWO POLITICAL OVERVIEWS**

**The Indian in America's Past**  
Jack D. Forbes  
1964; 181pp.  
**\$1.95** postpaid

from:  
Prentice-Hall, Inc.  
Englewood Cliffs, N. J. 07632

*This collection of excerpts from the literature is an effective antidote to at least some of the clichés of Indian-White relations. As wars go, the atrocities of the American invasion were standard, but the language, both from the invaders and the noble defeated, was well above grade. And the long confusing aftermath is still quick with fundamental problems.*

**Indian slavery in South Carolina, 1708**

In 1708, when the total population of South Carolina was 9,580, including 2,700 Negroes, there were 1,400 Indian slaves held in the province. Probably the number of Indians employed by the Carolina planters did not greatly increase thereafter . . . From an early time the exportation of captured Indian slaves was favored . . . Indian slaves were constantly escaping . . . and . . . their presence . . . raised the danger of conspiracies with enemy Indians . . . On all accounts it was better to ship off the Indians to New England or the West Indies, and to import Blacks . . . In the early eighteenth century (1706-1717) the *Boston News Letter* printed frequent advertisements of runaway Carolina Indians.

**The founders of Los Angeles, 1781**

California was settled after 1769 by Spanish-speaking persons who largely belonged to the *de razón* class. In fact, there *gente de razón* came to refer to all Spanish-speaking persons, including Europeans. The following list of settlers who founded Los Angeles in 1781 should provide some insight into the racial character of the Hispano-California population.

- (1) Felix Antonio Villavicencio, Espanol, 45, married to Maria de los Santos Sobernia, Indian, 30, one daughter.
- (2) Antonio Mesa, Negro, 36, married to Anna Gertrudes Lopez, Mulatto, 27, two daughters.
- (3) Jose Lara, Espanol, 50, married to Maria Antonia Campos, Indian, 20, one son and two daughters.
- (4) Jose Vanegas, Indian, 28, married to Mariana Aguilar, Indian, 20, one son.
- (5) Pablo Rodriguez, Indian, 25, married to Maria Rosario Noriega, Indian, 26, one daughter.
- (6) Manuel Camero, Mulatto, 30, married to Maria Tomosa, Mulatto, 24.
- (7) Jose Navarro, Mestizo, 42, married to Maria Rufina Dorotea, Mulatto, 47, two sons and one daughter.
- (8) Jose Moreno, Mulatto, 22, married to Maria Guadalupe, Mulatto, 19.
- (9) Basilio Rosas, Indian, 67, married to Maria Manuela Calistra, Mulatto, 43, five sons and one daughter.
- (10) Alejandro Rosas, Indian, 19, married to Juana Rodriguez, Coyote, 20.
- (11) Antonio Rodriguez, Chinese, 50, a widower with one daughter.
- (12) Luis Quintero, Negro, 65, married to Petra Rubio, Mulatto, 40, three daughters and two sons.

Since the children of the founders intermarried among themselves and with California Natives, it can be seen how within a very few generations nearly everyone could trace his ancestry to three continents.

**Cultural change: haircuts at gun point, 1896**

As with Samson of old, the Indians' wildness lay in their long hair, which the returned educated Indians wore because, as they boasted, "It made them wild." All energies were bent to compel the adult males to cut their hair and adopt civilized attire in vain . . . I directed the (Indian) police to cut theirs or leave the force. They reluctantly complied, but once accomplished they were only too eager to compel the rest, and they cheerfully, under orders, arrested and brought to me every educated Indian on the [Mescalero Apache] Reservation. There were twenty of these, gorgeous in paint, feathers, long hair, breechcloths and blankets . . . The Indian Office, at my request, issued a preemptory order for all to cut their hair and adopt civilized attire; and in six weeks from the start every male Indian had been changed into the semblance of a decent man, with the warning that confinement at hard labor awaited any backsliders. [The philosophy behind this action was that] the United States has for years footed the bills that maintained them in idleness, filth, immorality, and barbarism, and where a policy for their good has been adopted, they will not be consulted.

**Custer Died For Your Sins**  
Vine Deloria, Jr.  
1969; 279 pp.  
**\$5.95** postpaid

from:  
The Macmillan Company  
Front and Brown Streets  
Riverside, Burlington County  
New Jersey 08075

*Vine is the perfect dude to write of current Indian politics. Son of a missionary, enough Sioux to be a Sioux, long experience getting Indian kids into good schools, revved up by The National Indian Youth Council stand-up-and-fight meetings of the late fifties and early sixties, levered into the key position of Executive Director of the major Indian lobby The National Congress of American Indians, and after all that he's thirty-five and still funny. He has what Alvin Joseph warned me about, "the traditional American Indian cut-throat zeal for politics." Add that to his humor and his thoroughness and you have an unusually clear summary of the Indian situation now. His recommended route for Indian survival is strong land-based tribal identity.*

*Since Vine addressed his book primarily to young Indians, I can't resist a remark to young white Indian-savers: you can't help anybody by saving them; that's a self-defeat program. Relax and appreciate. Custer died for your sins. Also your virtues.*

*A long-haired artist famous former-dope-fiend commune white person I know is busy learning from his Indian friends at the Taos Pueblo: manners.*

From 1860 to 1880, tribes were confined to reservations, as the West was in its death throes. Churches began lobbying early in the 1860's at the Indian Bureau in Washington for franchises over the respective reservations. Thus one reservation would be assigned to the Roman Catholics, one to the Lutherans, one to the Methodists, and one to the Episcopalians. Other churches were prohibited from entry on a reservation once it had been assigned to a particular church and could enter only with permission from the other church. It always bothered me that these churches who would not share pulpits and regarded each other as children of the devil, should have so cold-bloodedly divided up the tribes as if they were choosing sides for touch football.

People have found it hard to think of the Indian Bureau without conjuring up the picture of a massive bureaucracy oppressing a helpless people. Right-wing news commentators delight in picturing the Indian as a captive of the evil forces of socialism and leftist policy. Liberals view the bureaucracy as an evil denial of the inherent rights of a free man.

It would be fair to say that the Indian people are ambivalent about all this. They fully realize that with no funds for investment in social services they are dependent upon the federal government for services which the ordinary citizen provides for himself and which other poor do not receive except under demeaning circumstances. Yet they are also fully aware that the services they receive are not gratis services. Many services are set out in early treaties and statutes by which Indians bargained and received these rights to services in return for enormous land cessions.

. . . the bureau should not be characterized as paternalistic. It should be characterized as "fear ridden," for the circle of fear that operates within it is much more detrimental to its efficiency than is its desire to paternalize.

Peoplehood is impossible without cultural independence, which in turn is impossible without a land base. Civil Rights as a movement for legal equality ended when the blacks dug beneath the equality fictions which white liberals had used to justify their great crusade. Black power, as a communications phenomenon, was a godsend to other groups. It clarified the intellectual concepts which had kept Indians and Mexicans confused and allowed the concept of self-determination suddenly to become valid.

I remember spending a whole afternoon talking with a number of hippies who had stopped in Denver on the way west. They were tribally oriented but refused to consider customs as anything more than regulations in disguise. Yet it was by rejecting customs that the hippies failed to tribalize and became comical shadows rather than modern incarnations of tribes.

Hippies, at least as I came to understand them, had few stable clan structures. They lived too much on the experiential plane and refused to acknowledge that there really was a world outside of their own experiences. Experience thus became the primary criteria by which the movement was understood. Social and economic stability were never allowed to take root.

Robert Thomas tells a famous story concerning the Cherokee who had a white man kill his children, steal his wife, sell his cattle, and burn his farm. The Cherokee chased the man for ten years and finally caught him. "Are you the guy who did all those things," the Cherokee asked. Yes, the white man admitted, he was the one.

"Well, you better watch that crap," the Cherokee warned. And that is my greatest concern for the Indian people. That we will be so damn polite that we will lose everything for fear of hurting someone's feelings if we object to the way things are going.

# CATALOG Procedure

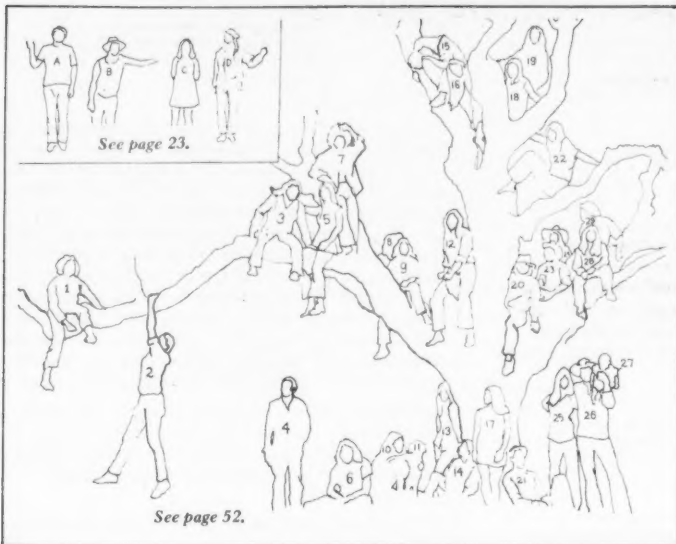

## Ordering from the CATALOG

Address orders to the supplier given with the item (unless you know of a better one; if you do, let us know).

If the price listed is not "postpaid", consult post office or express agency for cost of shipping from supplier's location to yours.

Add state sales tax if the transaction is within your state. (California sales tax is 5%)

Send check or money order with your order.

If the supplier gives you poor service, let us know. That information can be added to his review.

With some indicated items the CATALOG also will ship. There is no price difference with the service; the CATALOG gets the markup instead of the other guy, is all. Our service is fairly fast, especially for west coast orders. Bear in mind there's an inflation on. Prices are subject to rise without notice.

Generally, the closer the supplier is to you, the quicker and cheaper the shipping will be. If the item you're getting is delicate or if you are in a hurry, air express is a good deal. Anything overseas do by air, unless you want to wait a month or so for delivery.

## Suggesting and Reviewing

The validity of the information in the CATALOG is only as good as the transmitted experience of users. What would you add to the current CATALOG?

The CATALOG pays its reviewers \$10 an item for: getting familiar with the item, its usefulness, and its competition; evaluating the item; selecting samples of graphics or text (with page references) for the review; writing a 100-300 word review. Reviewers and first-suggesters of items are credited in the CATALOG.

We invite reviews that improve on present reviews or accompany suggestions for new items. On acceptance for CATALOG publication reviewers are paid \$10 per accepted review. Unused reviews are not returned. Appearance of submitted material doesn't matter unless it is meant to be camera-ready.

Reviewers are not paid for material that appears only in the \$1 Catalog.

## Corresponding

Commentary from CATALOG users that is of general interest is published in the \$1 Catalog. Critical comments, new design processes, no-cash techniques, news of specific enterprises, useful fantasies, design student work, time and trouble shortcuts, new uses for common or exotic materials, other realms for the CATALOG to consider, &c., &c.,—welcome.

Some tentative item reviews are carried in the \$1 Catalog without payment to the reviewer. If a \$1 Catalog review is later carried in the CATALOG, the reviewer is paid then.

## Subscribing to the CATALOG

\$8.00 per year. This includes six issues, two big ones (Fall and Spring) and four smaller ones. A Subscription form is at the back. Memorize your zip code. If your address changes, you must tell us, because the Post Office won't forward.

## Donating

Portola Institute, Inc. is a tax-exempt, non-profit educational corporation. Donations to Portola or the CATALOG may be deducted. Retaining subscriptions to the CATALOG are \$25 for one year (\$17 tax deductible). Sustaining subscriptions are \$100+ per year (\$92+ tax deductible). Names of retaining and sustaining subscribers are given in the CATALOG.

## Gifts and Informal Resale

CATALOGs are available in quantities of 5 or more at 25% discount. Thus you can get 5 CATALOGs for \$11.25, sell four, keep one, and come out ahead. There is no quantity discount on subscriptions.

For formal resale, see p. 54.

## Advertising

has become a nuisance. We're not carrying any more.

## CATALOG Policy with Suppliers and Users

The CATALOG is under no obligation to suppliers. Users are under no obligation to the CATALOG.

Suppliers (manufacturers, creators, etc.) may not buy their way into the CATALOG. Free samples, etc. are cheerfully accepted by CATALOG researchers; response not predictable. No payment for listing is asked or accepted. We owe accurate information exchange to suppliers, but not favors.

Our obligation is to CATALOG users and to ourselves to be good tools for one another.

## This issue

Gurney said meat and potatoes! and everybody said right on! Him and Diana brought the stuff in from the garden. Robin cooked it. Fred seasoned it. Hal and Steamboat served it up. So let's eat, and play match-the-picture-with-the-number of our dear friends at the store. (see page 52).

- |                    |                     |
|--------------------|---------------------|
| 1 George de Alth   | 17 Diana Shugart    |
| 2 Gurney Norman    | 18 Sonie Stoye      |
| 3 Troll            | 19 Fred Richardson  |
| 4 Jim Holdorf      | 20 Bernie Sproch    |
| 5 Marilyn          | 21 Stewart Brand    |
| 6 Steamboat        | 22 Sue              |
| 7 Austin Jenkins   | 23 Les Rosen        |
| 8 Peter Ratner     | 24 Francine Slate   |
| 9 Mary Jo Morra    | 25 Pam Smith        |
| 10 Shel Kaplan     | 26 J.D. Smith       |
| 11 Thaddeus        | 27 Delta Mist Smith |
| 12 Pandey          | 28 Donna            |
| 13 Sally           | 29 John Clark       |
| 14 Laura Besserman | A Hal Hershey       |
| 15 Jerry Fihn      | B Bud DeZonia       |
| 16 Lois Brand      | C Diane Erickson    |
|                    | D Robin Wakeland    |

Preparation of the CATALOG was done on an IBM Selectric Composer and Polaroid MP-3 camera. Printing by Nowels Publications, Menlo Park.

The WHOLE EARTH CATALOG is published at Portola Institute, 558 Santa Cruz Avenue, Menlo Park, California 94025 on the following schedule:

Fall CATALOG	— November	Spring CATALOG	— May
\$1 Catalog	— January	\$1 Catalog	— July
\$1 Catalog	— March	\$1 Catalog	— September

# FUNCTION

The *WHOLE EARTH CATALOG* functions as an evaluation and access device. With it, the user should know better what is worth getting and where and how to do the getting.

An item is listed in the *CATALOG* if it is deemed:

- 1) Useful as a tool,
- 2) Relevant to independent education,
- 3) High quality or low cost,
- 4) Easily available by mail.

*CATALOG* listings are continually revised according to the experience and suggestions of *CATALOG* users and staff.

# PURPOSE

We are as gods and might as well get good at it. So far remotely done power and glory—as via government, big business, formal education, church—has succeeded to point where gross defects obscure actual gains. In response to this dilemma and to these gains a realm of intimate, personal power is developing—power of the individual to conduct his own education, find his own inspiration, shape his own environment, and share his adventure with whoever is interested. Tools that aid this process are sought and promoted by the *WHOLE EARTH CATALOG*.

## SUSTAINING SUBSCRIBERS

Julia Brand  
Forrest A. Richey, Jr.  
Frederick W. Davis  
Clark Gesner  
John E. Clay  
Daniel M. Beach  
Pat Canavan  
Mrs. Alan Rosenthal  
Edward Voynow, Jr.  
Mr. & Mrs. Henry Abuza  
Nancy Dine  
Emily & Michael Zimmer  
Thomas T. Barts

Rockford, Illinois  
Charleston, West Virginia  
Kirkland, Washington  
Brooklyn, New York  
Glencoe, Illinois  
Cambridge, Massachusetts  
East Haven, Connecticut  
Princeton, New Jersey  
Albuquerque, New Mexico  
Rockville, Connecticut  
London, England  
Pembroke, Maine  
Cincinnati, Ohio

## RETAINING SUBSCRIBERS

Mark Albert  
John Doss  
Edmund Scientific Co.  
Henry Jacobs and Assoc.  
Edward Rosenfeld  
St. George Bryan  
Geoffrey Gates  
Peter Cornell  
Bill Davis  
Halbert Speer  
Constance Hwang  
Terry Borton  
Frederick and Karen Worden  
Don Winsberg  
Jeffrey Mitchell  
The Committee  
Mrs. Audrey Sabol  
Paul Kventsky  
Syntex Corporation  
Geoff Stirling  
Bernard Loven  
Ronald Jorgensen  
Gerald J. Driessen  
Joseph L. Bridger  
Joe & Ann McConnell, Jr.  
Vera L. Pratt  
Jim Temple  
Anthony D'Amato  
Bill Chaitkin  
David M. Meggyesy  
James J. Storrow III  
Eugene Lee  
Martin Stephen Moskof  
& Associates, Inc.  
Mr. & Mrs. Warren Rubin  
Edward Rosen  
Mrs. John Hauberg  
David Baxter  
Hendrik D. Gideonse  
Mr. & Mrs. Louis Mackall  
Michael Dreyfuss  
Barbara Schultz

San Francisco, California  
San Francisco, California  
Barrington, New Jersey  
Sausalito, California  
New York, New York  
Maui, Hawaii  
New York, New York  
Berkeley, California  
Boulder, Colorado  
Sea Cliff, New York  
Berkeley, California  
Cambridge, Massachusetts  
Sausalito, California  
Chicago, Illinois  
New York, New York  
San Francisco, California  
Villanova, Pennsylvania  
Houston, Texas  
Palo Alto, California  
Wickenburg, Arizona  
Minneapolis, Minnesota  
New York, New York  
Chicago, Illinois  
Woodstock, New York  
Point Reyes Station, California  
Cambridge, Massachusetts  
Adamant, Vermont  
Chicago, Illinois  
Syracuse, New York  
Saint Louis, Missouri  
New York, New York  
Warwick, Rhode Island  
New York, New York  
New York, New York  
New York, New York  
Seattle, Washington  
Beverly Hills, California  
Washington, D.C.  
Milford, Connecticut  
Trumansburg, New York  
Chicago, Illinois

Mrs. Nicholas DeWolf  
Jack Wise  
Mr. & Mrs. David Menkin  
Mr. & Mrs. Fred Lazarus III  
Mrs. Martin Dimbat  
Mrs. Charlotte L. Taylor  
D.T. Carter  
Monroe Litman  
Bob Mitchell  
Camiel Productions, Inc.  
Nancy Dibner  
Phil & Naomi Schechter  
Philip Ebersole  
Susan Christian  
J.R. Getsinger  
Donald R. Marsch  
David & Rosalyn Lounsbury  
The Gray Family  
Jim & Bitte Miller  
Bob & Mary Esther Woodbury  
Warren Besore  
Walter Holtkamp  
Bruce & Karen Frishkoff  
Martin Manasse  
Jim Zerdian  
Annette & Theodore Lucas  
Mark Engel  
Stephen Shore  
Edward Callahan  
Francis A. Martin, Jr.  
Dave Kramer  
Edmunds Enterprises  
Katrina Pflaumer  
Bruce & Louisa Stark  
Donal S. Jones  
Chris West  
Charles S. Dewey, Jr.  
Mark Matthews  
John Craig, Jr.  
Norman F. Caplan  
George Towne Baker III  
Tom & Cynthia Green  
Louise P. Smith  
Milo G. Clark, Jr.  
Jean Bullock  
Mr. & Mrs. Stephen Gerstman  
W. Cary Robinson  
Wendell Peabody  
Arthur Lundquist, Jr.  
Bruce C. Dale  
Yann Weymouth  
Rev. David C. Bergman  
Rev. Billy Spire  
Tom Evans  
James P. Miner  
Heinz von Foerster  
Lowell K. Cohn  
Carl Dubitsky  
Richard and Shirley Flint  
Paul Goldsmith

Boston, Massachusetts  
Texada Island, British Columbia  
Los Angeles, California  
Cincinnati, Ohio  
Concord, California  
Rochester, New York  
USS Grant County, FPO, New York  
New York, New York  
North Bergen, New Jersey  
Brooklyn, New York  
Westbrook, Maryland  
New York, New York  
Hagerstown, Maryland  
Roxbury, Massachusetts  
Bethesda, Maryland  
Chicago Heights, Illinois  
Carbondale, Illinois  
Portland, Oregon  
Geyserville, California  
Davis, California  
Washington, D.C.  
Cleveland, Ohio  
Lawrence, New York  
New York, New York  
New York, New York  
Detroit, Michigan  
Ben Lomond, California  
New York, New York  
Sioux Falls, South Dakota  
San Francisco, California  
Portland, Oregon  
Portland, Oregon  
New York, New York  
Madison, Wisconsin  
Washington, D.C.  
Taos, New Mexico  
New York, New York  
Columbus, Ohio  
Tulsa, Oklahoma  
Philadelphia, Pennsylvania  
Fullerton, California  
Brookville, Maryland  
Hillsborough, North Carolina  
San Diego, California  
Hillsborough, California  
Philadelphia, Pennsylvania  
Washington, D.C.  
Boise, Idaho  
Setauket, New York  
Boston, Massachusetts  
New York, New York  
Burr Oak, Michigan  
Portal, Arizona  
Cambridge, Massachusetts  
Boston, Massachusetts  
Urbana, Illinois  
New York, New York  
Danbury, Connecticut  
San Jose, California  
New York, New York

Frank Millsbaugh  
Jay A. Richardson, President,  
Consumer's Grass Co.  
Peter Sam  
Kenneth Leonard  
Kennon & Callihan  
Robert Stratton  
Dan Brown  
Margaret M. Thomas  
Joe Richardson  
Kathleen Chase  
Orsin Whyte  
Stephen Sanders  
W.M. Miller  
Mary Netzou  
Dilexi Foundation  
Donald C. MacDonald, Jr.  
Queens Magazine  
Jennifer & Bill Delafield  
James G. Mason  
Don Winsberg  
Guy Pignolet  
Jerry Driessen  
Mary Ohlson  
Michael Strater  
Gil Walter  
Artcraft Displays  
Robert Hamburg  
Tom E. Stucker  
Orn East  
Arthur Satz  
Jim Woodward  
Sid Dimond Associates, Inc.  
Mr. C.B. Robertson  
Robert Mitchell  
Joseph Myers  
Elizabeth Kent Gay  
Rodney Boxter  
Lincoln Magill  
Victor A. Curran  
Irene Silverman  
Alex McDonell  
Stewart Iglehart, Jr.  
Maughn Matsuoka  
Mrs. Arthur White  
Thomas Cray  
ZBS Media, Inc.  
Susan & Richard Roman  
Nelson M. Griggs  
Richard Isackson  
Lee Hirsey  
W.M. Ittmann  
John Reinemund  
Robert Zesiger  
Jerome Sands  
David Baxter  
Gurdon Wattles  
Hugo L. Ingram  
M.M. Newell

New York, New York  
Toronto, Canada  
San Diego, California  
Urbana, Illinois  
Baton Rouge, Louisiana  
Riverdale, New York  
St. Simons Island, Georgia  
Washington, D.C.  
San Diego, California  
Umbertide, Italy  
Accokeek, Maryland  
Estepena, Spain  
Fresno, California  
Thiensville, Wisconsin  
San Francisco, California  
Minneapolis, Minnesota  
London, England  
Philadelphia, Pennsylvania  
Chicago, Illinois  
Chicago, Illinois  
Ithaca, New York  
Chicago, Illinois  
San Francisco, California  
San Francisco, California  
Chicago, Illinois  
Duluth, Minnesota  
Andes, New York  
Covina, California  
Bridgehampton, New York  
New York, New York  
Princeton, New Jersey  
Boston, Massachusetts  
Balboa, Canal Zone  
New Jersey  
Lexington, North Carolina  
Calais, Vermont  
Wichita, Kansas  
Demarest, New Jersey  
Havre de Grace, Maryland  
Ann Arbor, Michigan  
New York, New York  
Delray Beach, Florida  
Cambridge, Maryland  
San Francisco, California  
Bloomington, Indiana  
Ft. Edward, N.Y.  
Pittsburgh, Pennsylvania  
Boys, Maryland  
Bay City, Michigan  
Hancock, Massachusetts  
Williamstown, Massachusetts  
Los Angeles, California  
APO San Francisco, California  
Bethany, Connecticut  
Beverly Hills, California  
New Haven, Connecticut  
Huntsville, Alabama  
Albany, New York

# Spring '70 Catalog Corrections

**Operating Manual for Spaceship Earth** **p.4**  
*is now available in paperback for \$1.95*

from:  
 Simon & Schuster, Inc.  
 630 Fifth Ave.  
 New York, N.Y. 10020

or WHOLE EARTH CATALOG



**Earth Times** **p.8**

*has ceased publication after its fourth issue. We don't know why, but we're sure sorry.*

**The Tao of Science** **p.15**

*has gone up from \$1.95 to \$2.45 postpaid*

from:  
 from:  
 The M.I.T. Press  
 50 Ames St., Room 765  
 Cambridge, Mass. 02142

or WHOLE EARTH CATALOG

**Structural Design in Architecture** **p.20**

*Correct price is \$18.95*

from:  
 Prentice-Hall, Inc.  
 Englewood Cliffs, New Jersey 07632

or WHOLE EARTH CATALOG

**Futuro** **p.21**

*Their display house has moved to 20th Street and John F. Kennedy Blvd. in Philadelphia.*



**Audel Guides** **p.24**

*Mason's & Builders Guide, vols. II & IV are also now available from Whole Earth Catalog, in addition to the vols. I & II listed.*

**Adobe Construction Methods** **p.27**

*is now out of print, with "no plans to revise or reissue it."*

**Windmills** **p.38**

*Correct address for Aermotor is:*

Aermotor  
 2225 W. Curtiss  
 Downer's Grove, Ill. 60515



**Step-by-Step Craft Series** **p.42**

*Correct access is:*

Western Publishing Co.  
 Order Department  
 Wayne, New Jersey

or WHOLE EARTH CATALOG



**Paxton Lumber Company** **p.43**

*"is a wholesale distributor of Fine Hardwoods and Pines to Industrial and School accounts" . . . and "is not set up to handle retail business to individuals." Guess that means us.*

**The School of Blacksmithing** **p.45**

*mentioned alongside The Art of Blacksmithing has a new address:*

Turley Forge  
 Box 2051  
 Santa Fe, New Mexico 87501

**An Introduction to Cybernetics** **p.66**

*is now available for \$3.25*

from:  
 Barnes & Noble, Inc.  
 105 Fifth Ave.  
 New York, N.Y. 10003

or WHOLE EARTH CATALOG

**Foods by Mail** **p.82**

*NEW AGE NATURAL FOODS has decided not to go into the mail order business after all. San Franciscans can still shop at 1326 Ninth Ave., San Francisco.*

**On Death and Dying** **p.89**

*is now available in paperback for \$1.95*

from:  
 Macmillan Co.  
 Front and Brown Streets  
 Riverside, Burlington County,  
 New Jersey, 08075

or WHOLE EARTH CATALOG

**Earth Flag**

*is no longer available in quantity from San Francisco. Address orders of 10 or more to:*

"WE" Inc.  
 19 Troutman St.  
 Brooklyn, N.Y. 11206

**Fleming Bottle and Jug Cutter** **p.97**

*The small (\$3.95) bottle cutter has been discontinued. The larger one has been improved and is up from \$6.80 to \$7.75 postpaid*

from:  
 Fleming Bottle & Jug Cutter  
 2110 S.W. 173rd Place  
 Seattle, Wash. 98116

or \$6.80 postpaid from Whole Earth Catalog

**Federal Domestic Assistance** **p.100**

*The Catalog of Federal Domestic Assistance, formerly free from OEO offices, is now \$6.75*

from:  
 Superintendent of Documents  
 Government Printing Office  
 Washington, D.C. 20402

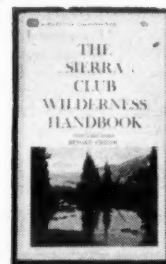

**The Sierra Club Wilderness Handbook** **p.103**

*is now out of print, with no plans to reprint as of now.*

**U.S.G.S. Topographic Maps** **p.117**

*New address for the free index maps:*

from:  
 Map Information Service  
 U.S. Geological Survey  
 Dept. of the Interior  
 Washington, D.C. 20240

*New access on ordering the 50¢ maps: Maps covering areas in the States west of the Mississippi River (including all of Louisiana and Minnesota) should be ordered directly from:*

Distribution Section  
 Geological Survey  
 Federal Center  
 Denver, Colo. 80225

*Maps for areas east of the Mississippi River (including Puerto Rico and the Virgin Islands) should be ordered from:*

Distribution Section  
 Geological Survey  
 1200 South Eads St.  
 Arlington, Virginia 22202

*A single order combining both eastern and western maps may be placed with either office.*

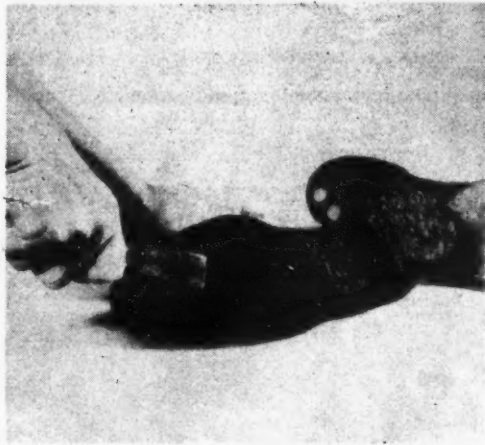

**Sole-Saver**

Correct address is:

Carpet Products Co.  
P.O. Box "S"  
Central Square, New York 13036

**p.118**

**How to Travel Without Being Rich**

is up from \$1.95 to **\$2.50**

from:  
Grosset & Dunlap, Inc.  
51 Madison Ave.  
New York, N.Y. 10010

or WHOLE EARTH CATALOG

**The Lives of Children**

is now available in paperback for **\$1.95**

from:  
Random House, Inc.  
201 East 50th St.  
New York, N.Y. 10022

or WHOLE EARTH CATALOG

**p.121**

**Piaget And Knowledge**

Correct price is **\$8.95**

from:  
Prentice-Hall, Inc.  
Englewood Cliffs, New Jersey 07632

or WHOLE EARTH CATALOG

**p.123**

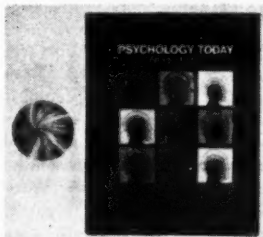

**Psychology Today**

The \$16.95 listed price was a pre-publication price. Now it's **\$24.95**

from:  
CRM Books  
1104 Camino Del Mar  
Del Mar, Calif. 92014

or WHOLE EARTH CATALOG

**p.132**

**Fall '69 Catalog Corrections**

These books were not listed in the Spring Catalog, but are still stocked at the Truck Store.

**Cymatics**

is now out of print.

**p.9**

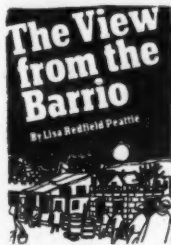

**The View from the Barrio**

is now available in paperback for **\$1.95**

from:  
The University of Michigan Press  
615 East University  
Ann Arbor, Michigan 48106

or WHOLE EARTH CATALOG

**p.16**

**Wild Foods**

Stalking the Healthful Herbs  
Stalking the Wild Asparagus  
Stalking the Blue-Eyed Scallop  
By Euell Gibbons

All are now available in paperback for **\$2.95**

from:  
David McKay Co., Inc.  
750 Third Ave.  
New York, N.Y. 10017

or WHOLE EARTH CATALOG

**p.39**

**Japanese Homes and Their Surroundings**

has gone up from \$2.50 to **\$3.20** postpaid

from:  
Dover Publications  
180 Varick St.  
New York

or **\$3.00** postpaid from WHOLE EARTH CATALOG

**Handbook of Prescription Drugs**

had gone out of print. It's been re-issued as

**New Handbook of Prescription Drugs, \$1.25**

from:  
Ballantine Books  
101 Fifth Ave.  
New York, N.Y. 10003

or WHOLE EARTH CATALOG

**p.82**

**Dune**

has gone up from \$.95 to **\$1.25** postpaid

from:  
Ace Books, Inc.  
1120 Avenue of the Americas  
New York, N.Y. 10036

or WHOLE EARTH CATALOG

**p.95**

**An Alright Wheelwright Book**

Wow. All you want to know (almost all) about wheelwrighting. Selecting trees, cutting and seasoning lumber, choosing the pieces for the various parts, shaping the stocks, spokes felloes (rhymes with bellies). Tyreing, bending, boxing, etc. Plus much about building waggons and carts.

All this through the eyes of a man, caught up by Ruskin with the idea that man's only decent occupation was in handicraft, running a wheelwright's shop through the 1880's. Interesting view of machines displacing skilled craftsman.

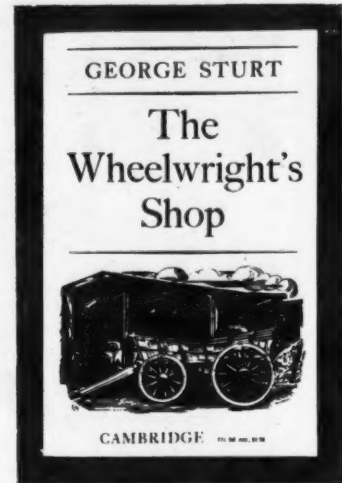

**The Wheelwright's Shop**  
by George Sturt, 1923 - 1963

from:  
Cambridge University Press  
32 East 57th Street  
New York, New York

**\$1.95**

The special problem the sawyers knew how to tackle looks simple enough at the outset. What was it, save to get the timber—the oak, the ash, the elm, the beech—slip or slithered into sizes that experts might handle afterwards? Experts already had thrown the timber; others had carted it to the yard; another still—the master-wheelwright—had marked it into lengths and was at hand to direct the sawyers throughout; and what else was there for them to do, except supply mere brute strength? That looked about all they were fit for, with their stupid brains and brawny arms.

Yet, in point of fact, they themselves, you found, were specialists of no mean order when it came to the problem of getting a heavy tree—half a ton or so of timber—on a saw-pit and splitting it longitudinally into specified thicknesses, no more and no less. What though the individuals looked stupid? That lore of the English tribes as it were embodied in them was not stupid any more than an animal's shape is stupid. It was an organic thing, very different from the organized effects of commerce.

[Reviewed by Fred Richardson]

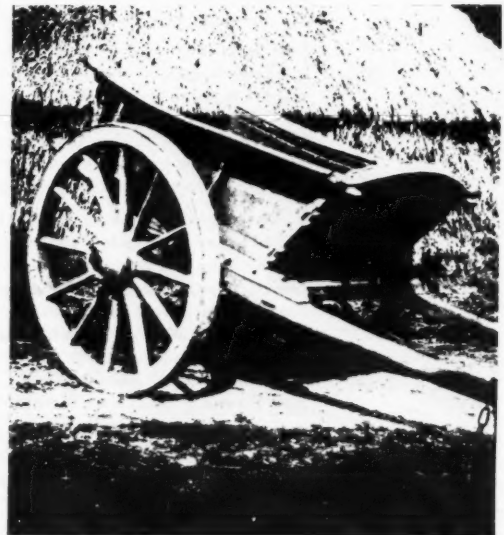

# Staff



Photo by Greg Dranhall

## Introducing: Divine Right's Bus, Urge

I was a fairly straight '63 VW microbus till Divine Right got me, a good clean red and white seven passenger job with five new re-capped tires and near perfect upholstery. The only bad thing that ever happened to my seats was the Muncy's youngest kid use to puke on it all the time. The Muncys were my first owners. They bought me new in Germany when the old man was stationed over there in the army. He was a Master Sergeant in an infantry outfit, a little old for that kind of work maybe, but he liked it well enough to volunteer for Vietnam when that war started to heat up. The Muncys brought me back to the states, and, after the sergeant got blown up by a land mine, his wife Marie traded me in on a Falcon.

Two days on a car lot is a long time when you're not used to it. It was hot and damn boring, so even though this guy Divine Right looked pretty weird, I was so eager to get on the road again I felt grateful to him for buying me, although it did piss me off a little when the car dealer only asked eight hundred and fifty dollars. Divine Right paid the man with cash he'd got from a big grass score that morning, and if I could whistle I'd have whistled when we drove away together.

Which goes to show you how much I knew about freaks in those days. Shit. I hadn't gone five hundred miles with that son of a bitch before I'd of given my goddamn fuel pump to be back in the parking lot. That bastard drove me from Boston to Chicago to Indianapolis without once checking my oil. I found out later he didn't even know where my goddamn oil stick was. Drove non-stop too, all day, all night, the only time I got even a little rest was when he'd slow down long enough to refuel or buy a rat-burger. If his brother-in-law in Indianapolis hadn't noticed I was a quart and a half low I'd probably have thrown a rod as soon as we hit the next freeway.

D.R. doesn't seem to like them much, but his sister and brother-in-law are nice people. Ed understands about cars. He drives a stock-car some, he knows how to take care of machines. He tried to tell D.R. about preventive maintenance, but he was too stoned to pay attention. He was on speed that trip, out of his skull on meth and reds. He told Ed he had to split in order to make the Ultimate Rendezvous. Ed said What's an Ultimate Rendezvous? But D.R. just grinned and started my motor and drove away. His sister Maxine came out of the house with a box of sandwiches for his trip, but D.R. couldn't wait another five seconds to receive them.

So you get some idea of where D.R.'s head was at. He was the kind of guy who never had the faintest idea how he affected things. He could fuck over a nice '63 VW microbus he'd just paid eight hundred and fifty dollars for, and never blink an eye. I don't know what was the most humiliating, having my working parts ignored, or all that stupid paint sprayed all over my body. Inside and outside, I suffered both places. It's one thing to go around feeling bad because you're low on oil; but when you have to *look* like a made-up whore, it gets to be a bit much. Housepaint, Day-Glo, fingernail polish, you name it and I got smeared with it. Sometimes he'd pull off into the emergency lane of some big interstate and start painting on the spot. Said God was sending him directions how to do it. Bullshit. Sometimes he'd pick up hitch-hikers and tell them to lean out the window and paint while he drove. By the time him and those weird friends of his got through I looked like a watercolor that got rained on. It was awful.

But I survived. I don't know how but I did. Well, yes I do know too. It was Estelle. There's no doubt about it, that little lady saved my ass from the junkyard. She was one nice person, that Estelle. There was something kind of sad about her, something a little, what? Vulnerable, I guess. It seemed like she cried a lot. But she sure knew how to be nice to an old broken-down bus. She'd wash me, and empty my ash trays. Sometimes D.R. would be too stoned to drive and Estelle would take over, and it would just be so fine, just me and her cruising quietly across the country through the night. That was the thing about Estelle. She understood cruising, she understood roads, and traffic, she knew how to flow with things in motion. I never did understand what she saw in D.R. But, I guess it wasn't my place to have opinions about people. My job was to carry them around from place to place while they acted out their story, and although I resented it most of the time, I did my best. It was painful, but I do have to say it was interesting. I kind of wish I could have a voice in the Last Catalog, to tell my side of the story. But as far as I know I don't get one. They say there's too many points of view already to clutter it up even more with a goddamn talking car. So I guess this is the only chance I'll have to speak my mind. It aint much of a chance, but, when you've been down as long as I have, you get grateful for small favors. So goodbye. See you in the funny papers, maybe.

Gurney Norman

**Statement of Income and Surplus**  
June 1, 1970 to June 30, 1970  
(Unaudited)

	Mail Orders & Store	Catalogues	Total
<b>Income:</b>			
Sales, less returns	\$ 23,402.87	\$ 87,488.10	\$ 110,890.77
<b>Cost of sales:</b>			
Salaries and wages	2,264.99	2,662.50	4,927.49
Merchandise	11,701.43		11,701.43
Printing		33,844.80	33,844.80
Distribution		1,209.52	1,209.52
Outside services	238.62	191.12	429.74
Supplies and other direct charges		557.13	557.13
Depreciation	32.50		32.50
Travel and automobile expenses		75.00	75.00
Rent		50.00	50.00
General and administrative expenses, Exhibit 3	2,515.61	9,463.48	11,979.09
<b>Total</b>	<b>16,753.15</b>	<b>48,053.55</b>	<b>64,806.70</b>
Net income before taxes	6,649.72	39,434.55	46,084.27
Provision for Federal income taxes	1,243.00		1,243.00
Net operating income	\$ 5,406.72	\$ 39,434.55	44,841.27
<b>Other income:</b>			
Postage			370.88
Donations			200.05
Miscellaneous			242.58
			813.51
<b>Net income and Surplus</b>			<b>\$ 45,654.78</b>

VERNON M. JOHN  
CERTIFIED PUBLIC ACCOUNTANT  
Whole Earth Division of  
Portola Institute  
Balance Sheet  
June 30, 1970  
(Unaudited)

Exhibit 1

Assets	
<b>Current assets:</b>	
Cash—Bank of California, commercial account	\$ 37,238.64
—Bank of California, restricted account	4,420.14
—Wells Fargo Bank, savings account	15,840.44
—Bay View Federal Savings & Loan	14,000.00
	71,499.22
Accounts receivable, catalogues and mail order	\$ 116,814.76
Accounts receivable, other	142.15
U.S. Treasury bills	30,000.00
Inventories:	43,403.78
<b>Total current assets</b>	<b>261,859.91</b>
<b>Property and equipment:</b>	
Furniture and equipment	8,264.97
Less: Accumulated depreciation	54.50
	8,210.47
<b>Total Assets</b>	<b>\$ 270,070.38</b>
Liabilities and Capital	
<b>Current liabilities:</b>	
Accounts payable, trade	\$ 27,158.20
Loan payable, employee	3,575.00
Equipment contract payable	700.00
Taxes payable	9,560.05
Interest payable	366.85
Reserve for Federal income taxes	1,243.00
<b>Total liabilities</b>	<b>42,597.10</b>
<b>Capital:</b>	
Surplus, June 1, 1970	\$ 181,818.50
Net income and surplus, Exhibit 2	45,654.78
	227,473.28
<b>Total Liabilities and Capital</b>	<b>\$ 270,070.38</b>

The accompanying Statement of Income and this Balance Sheet at June 30, 1970 were not audited by me and, accordingly, I cannot express an opinion on them.

## Constitutional Victories for Prison Inmates

Prison inmates can now read The Whole Earth Catalog thanks to a recent decision of a three judge court. The catalog had been on a list of "disapproved" periodicals that included The Black Scholar, The Berkeley Barb, The Realist, and Avant Garde, denied to prison inmates by the Department of Corrections. A three and one half year battle by the American Civil Liberties Union of Northern California in support of the constitutional rights of prisoners was required in order to remove this censorship.

### Banned Books

Ingram had been denied access to books dealing with drugs (because, authorities said, they "glorified crime") and the magazines The Realist and Avant Garde. The magazines were on a list of "disapproved" periodicals that included The Black Scholar, The Whole Earth Catalogue and the Berkeley Barb. Halvonik contended in Ingram's behalf that "glorification of crime" and "advocacy of crime" were not, under the Penal Code, justifiable grounds for censoring books and magazines. The Court so held. Justice Sullivan stated:

"At the outset it is clear that the strong language chosen by the Legislature to state the basic right indicates an intention that any limitation on that right beyond those specifically set forth is to be viewed with circumspection... [T]he judgment of the Legislature expressed in section 2600 would seem to be that free access to all printed materials which are accepted for distribution by the United States Post Office—excepting those which are obscene or which tend to incite activities posing a threat to prison discipline—is more in accord with legitimate penal objectives than limited access according to the views of particular prison authorities on the rehabilitative effect of such materials. We do not consider this view to be wholly lacking in rational support. It may well be that even persons who have committed antisocial acts warranting their imprisonment may derive greater rehabilitative benefits from a relatively free access to the thoughts of all mankind as reflected in the published word than they would derive from a strictly controlled intellectual diet."

(From American Civil Liberties Union News)



### Production Costs

Printing and Binding	\$3,400
Salaries	1,674
Composer	300
Film & Photo Paper	120
Art Supplies	75
Telephone	40
Rent	200
Mailing and Postage	650
<b>Total \$6,459 (not including research)</b>	<b>\$6,459</b>
40,000 copies printed September 1970	
Unit cost 16¢	

### Suggestions for the WHOLE EARTH CATALOG

An item is listed in the CATALOG if it is deemed:

- 1) Useful as a tool,
- 2) Relevant to independent education,
- 3) High quality or low cost,
- 4) Easily available by mail.

Please fill in as much information as you possibly can; it helps a lot.

Date \_\_\_\_\_

My name \_\_\_\_\_

Address \_\_\_\_\_

Phone \_\_\_\_\_ ZIP \_\_\_\_\_

I SUGGEST:

Title of book or name of item: \_\_\_\_\_

Author: \_\_\_\_\_

Price: \_\_\_\_\_

Publisher or supplier: \_\_\_\_\_

Address: \_\_\_\_\_

ZIP \_\_\_\_\_

If an item suggested is intended to replace an item already in the CATALOG, please fill in the item to be replaced: \_\_\_\_\_

I would like to write a review.

Attached is a review of this item.

I would recommend \_\_\_\_\_  
(name, address, phone)

to review this item.

Additional information/review: \_\_\_\_\_

# Whole Earth Truck Store



A major research source of ours is the Menlo Park Whole Earth Truck Store, which stocks most of the items in the CATALOG. We see who's buying what. We hear complaints and suggestions. We try out items that might be in the next CATALOG. We have a place where friends can come and see what's happening.

Hours: Monday-Saturday, 9 am - 6 pm  
 558 Santa Cruz Avenue, Menlo Park, CA 94025  
 Phone: (415) 323-0313

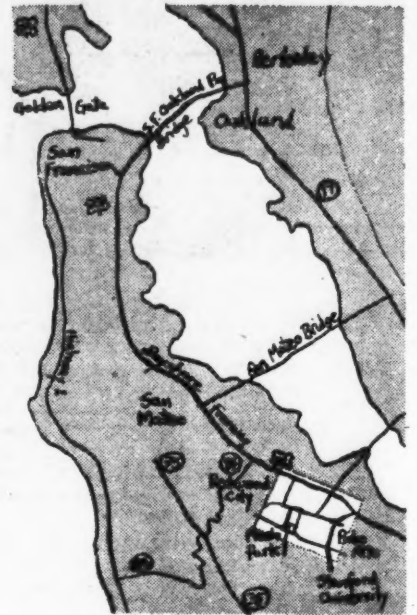

## Catalog Distribution

Book People, by agreement with the Bookworks, announces national distribution of

### THE WHOLE EARTH CATALOG

The Whole Earth Catalog is published six times a year—2 large ones (Spring and Fall) and 4 smaller ones. As the materials are not completely duplicated, you can carry everything in print.

Currently available:

- Spring 1969 CATALOG \$4
- July 1969 Supplement \$1
- September 1969 Supplement \$1
- Fall 1969 CATALOG \$4
- January 1970 \$1 Catalog
- March 1970 \$1 Catalog
- Spring 1970 cCATALOG \$4
- July 1970 \$1 Catalog
- September 1970 \$1 Catalog

All retail, wholesale, and library distribution is processed through Book People; please do not direct your order to Whole Earth Catalog Store.

### TERMS:

- Retail: 1-14 assorted 30%
- 15-up " 40%
- Wholesale: 100 up assorted 50%  
 (qualification: meet the requirements of our certificate of wholesale endeavor)

Invoices are due net 10 EOM  
 Accounts 30 days overdue will not be shipped.  
 Credit accounts will be established through your Dun & Bradstreet rating, new businesses are advised to enclose their financial statement.  
 Returns: request label. Unauthorized returns will be discounted at a penalty.

### NOTICE TO NEW ACCOUNTS:

For immediate shipments, please enclose check to cover order. Catalogs are \$4.00 retail for Spring and Fall 69; \$3.00 for Spring 70; \$1.00 retail for the others (Jan, Mar, July, Sept). Figure your discount. Allow one pound for each catalog or each seven supplements. Figure your freight charges at Book Post rate:

12¢ first pound  
 6¢ each additional pound

Thank you,  
 Book People  
 2940 Seventh Street  
 Berkeley, Ca. 94710  
 Phone: (415) 549-3033

Note: Book People buys CATALOGS from us at 56%. So they get either 6% or 16% of the sale price. They earn it.

## Subscription Form

IF YOU CHANGE YOUR ADDRESS, PLEASE TELL US. THE POST OFFICE ALMOST NEVER FORWARDS!

Send to: **WHOLE EARTH CATALOG**  
 558 Santa Cruz Avenue  
 Menlo Park, California 94025

\$ \_\_\_\_\_ Amount enclosed

- \$ 3.00  One issue of 1970 Spring CATALOG
- \$ 1.30  One issue of 1969 Fall CATALOG
- \$ 4.00  One issue of 1969 Spring CATALOG
- \$11.25  Five copies of 1970 Spring CATALOG
- \$ 5.00  Five copies of 1969 Fall CATALOG
- \$15.00  Five copies of 1969 Spring CATALOG
- \$ 8.00  One year subscription: six CATALOGs, two large (Fall & Spring) and four smaller.

U.S. and Canada  
 \$9 surface elsewhere;  
 \$14.60 air elsewhere.

- starting issue:  1969 Spring CATALOG     1969 July Supplement     1969 Sept. Supplement  
 Check one box only     1969 Fall CATALOG     1970 Jan. \$1 Catalog     1970 March \$1 Catalog  
                                    1970 Spring CATALOG     1970 July \$1 Catalog

- \$ 7.25  Five-issue Subscription starting with 1970 September \$1 Catalog
- \$ 7.25  Four-issue Subscription starting with 1970 Fall Catalog
- \$ 25  One year Retaining Subscription
- \$100  One year Sustaining Subscription

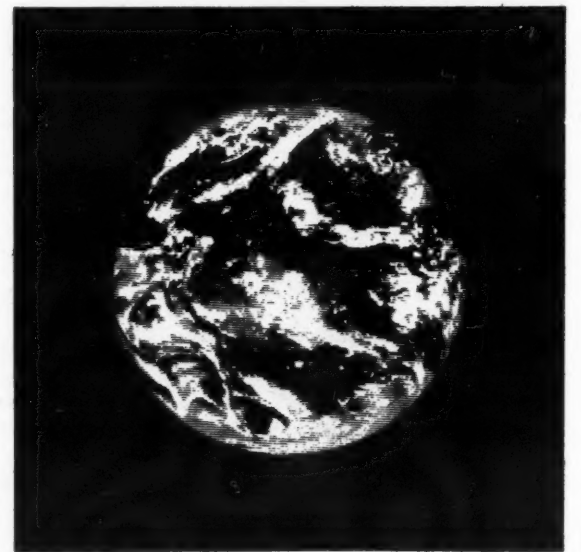



**AA Acme Art Academy** is a cooperative school and workshop for the entire *local* community. The extent of activities is limited only by space and people willing to share their skills with others. Membership in the cooperative is \$25 per quarter. Membership allows unlimited classes and access to equipment. Scholarships are available by application to the scholarship committee.

Current class subjects:  
 Painting and Drawing  
 Pottery and Glassblowing  
 Sculpture  
 Printmaking  
 Textiles  
 Photography & Film-making

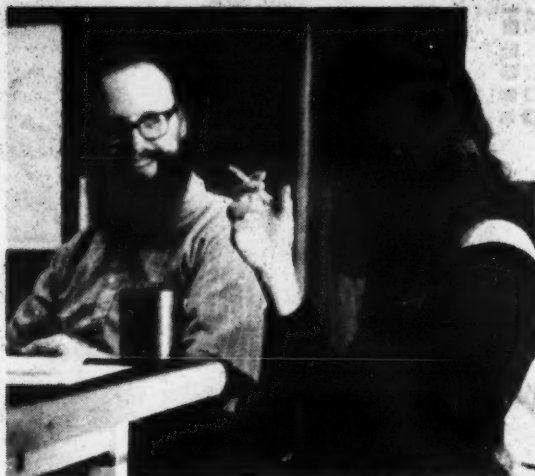

Jim Kerr, Kay Matthews

**Scripps Off-Campus Project Center** is a project-oriented place for *local* high school age people. High school kids come to do projects of their choosing, and are helped with leads to equipment, people, and money resources. Projects include movies of various kinds, jewelry making, underground newspapers, brain-wave research, a leather-making project, making a flying saucer, etc. "We have also generated some projects in the local public schools that, from our experience of working with high school students, we felt were desired and necessary."



**Big Rock Candy Mountain**

**A LEARNING TO LEARN CATALOG:**

- Learning Process—
- Environmental Education—
- Home Learning—
- Classroom Materials and Methods—
- Self-Discovery—

psychosynthesis techniques, computer symbiosis, experiential learning narratives, interaction process; school and classroom design, environmental spreading methods, films on schools, outdoor classrooms, games; toys and playthings, bioenergetics, yoga, childrearing; classroom materials, liecester materials, cardboard carpentry, teaching methods, nature labs, audio-visual aids, the bag, the box, and the bin; gurdjieff books, self-discovery, meditation texts gestaltstuff, theater games, simulations.

Descriptions, excerpts, and evaluations.

**BIG ROCK CANDY MOUNTAIN  
 PORTOLA INSTITUTE, INC.**

1115 Merrill Street, Menlo Park, Ca. 94025

Summer 1970 \$4.00  
 Fall 1970 \$1.00



Dick Raymond,  
 President



Truck Store.

**Whole Earth Truck Store & Catalog** is an evaluation and access source, providing the user with information about tools—both books and hardware—which enable him to shape his environment, external and internal as well as to begin to realize his fantasies. The Truck Store publishes the Whole Earth Catalog twice annually along with four supplements; it lists and evaluates materials and processes and provides the user with a mail order route to the desired source. At 558 Santa Cruz Avenue in Menlo Park, a permanent store sells most of the books and a few of the tools, and provides a base for the exchange of information via the mails.

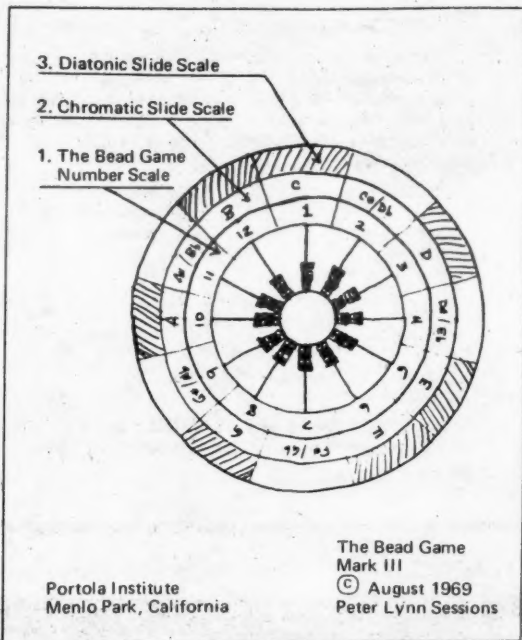

The Bead Game  
 Mark III  
 © August 1969  
 Peter Lynn Sessions

Portola Institute  
 Menlo Park, California

**Music Resources Program** is an exploration of innovative approaches to music composition and music teaching at all age levels. The program includes non-rote techniques, and manual devices to aid in composition, learning and performance. The director, Peter Sessions, is currently working on a self-instruction book for the composition of music, using a new learning device, The Bead Game.

**Portola Institute**

was established in 1966 as a non-profit corporation to encourage, organize, and conduct innovative educational projects. The Institute relies for support on private foundations and public agencies, to whom specific project proposals are submitted.

Because Portola Institute is a private organization with no need to produce profits or guarantee "success", it can experiment with new and unusual educational projects that would be difficult to administer within more structured organizations. For this reason the staff and facilities of the Institute are deliberately kept small and flexible.

Within its framework a wide variety of projects dealing with innovative education can be created as people with ideas are able to interest people with funds. New projects are always being considered, both within the existing divisions and programs, and within as yet unexplored realms of the learning experience.

Please send me information about Portola Institute.

Especially \_\_\_\_\_

Name \_\_\_\_\_

Address \_\_\_\_\_

Zip \_\_\_\_\_

**Portola Institute, Inc.**  
 1115 Merrill Street  
 Menlo Park, California 94025

Address inquiries about AA Acme Art Academy and Scripps Off-Campus Project Center to:

815 Shasta Street  
 Redwood City, California 94063

WHOLE EARTH CATALOG  
558 Santa Cruz Avenue  
Menlo Park, CA 94025

SECOND CLASS  
PERMIT PENDING  
MENLO PARK, CA

