

# WHOLE EARTH CATALOG

*access to tools*



Fall 1969  
\$4

## FUNCTION

*The WHOLE EARTH CATALOG functions as an evaluation and access device. With it, the user should know better what is worth getting and where and how to do the getting.*

*An item is listed in the CATALOG if it is deemed:*

- 1) Useful as a tool,*
- 2) Relevant to independent education,*
- 3) High quality or low cost,*
- 4) Easily available by mail.*

*CATALOG listings are continually revised according to the experience and suggestions of CATALOG users and staff.*

## PURPOSE

*We are as gods and might as well get good at it. So far, remotely done power and glory—as via government, big business, formal education, church—has succeeded to the point where gross defects obscure actual gains. In response to this dilemma and to these gains a realm of intimate, personal power is developing—power of the individual to conduct his own education, find his own inspiration, shape his own environment, and share his adventure with whoever is interested. Tools that aid this process are sought and promoted by the WHOLE EARTH CATALOG.*

## SUPPLEMENT FUNCTION

*The Supplement corrects and updates information in the most recent CATALOG, carries on-going research toward the next CATALOG, and publishes what doesn't fit in the CATALOG but does relate to the use of tools.*

### SUSTAINING SUBSCRIBER

Julia Brand Rockford, Illinois

### RETAINING SUBSCRIBERS

Mark Albert San Francisco, California  
John Doss San Francisco, California  
Edmund Scientific Co. Barrington, New Jersey  
Henry Jacobs and Assoc. Sausalito, California  
Edward Rosenfeld New York, New York

St. George Bryan  
Geoffrey Gates  
Peter Cornell  
Bill Davis  
Halbert Speer  
Constance Hwang  
Terry Borton  
Frederic and Karen Worden  
Don Winsberg  
Jeffrey Mitchell  
The Committee  
Mrs. Audrey Sabol  
Paul Kventsky

Maui, Hawaii  
New York, New York  
Berkeley, California  
Boulder, Colorado  
Sea Cliff, New York  
Berkeley, California  
Cambridge, Massachusetts  
Sausalito, California  
Chicago, Illinois  
New York, New York  
San Francisco, California  
Villanova, Pennsylvania  
Houston, Texas

Syntex Corporation  
Geoff Stirling  
Bernard Loven  
Ronald Jorgensen  
Gerald J. Driessen  
Joseph L. Bridger  
Joe & Ann McConnell, Jr.  
Vera L. Pratt  
Jim Temple  
Anthony D'Amato  
Bill Chaitkin  
David M. Meggyesy  
James J. Storrow III

Palo Alto, California  
Wickenburg, Arizona  
Minneapolis, Minnesota  
New York, New York  
Chicago, Illinois  
Woodstock, New York  
Point Reyes Station, California  
Cambridge, Massachusetts  
Adamant, Vermont  
Chicago, Illinois  
Syracuse, New York  
Saint Louis, Missouri  
New York, New York

© 1969 Portola Institute, Inc.

All rights reserved under Pan-American and International copyright conventions.

# CONTENTS

Star (\*) indicates NEW ITEM.

## Under- standing Whole Systems

- 2 CATALOG Procedure
- 3 Buckminster Fuller
- 4 Population Bomb  
Population, Evolution  
and Birth Control
- \*State of Siege
- \*Second Genesis
- 5 Science and Survival
- \*The Subversive Science
- \*Concepts of Ecology
- 6 Man's Domain  
Cosmic View
- \*Star Maker
- 7 \*Andromeda Galaxy  
Full Earth  
Earth Photographs
- \*Observer's Handbook  
Exploring Space with a Camera
- 8 Geology Illustrated  
Surface Anatomy
- \*Structural Integration
- 9 \*Cymatics  
Sensitive Chaos
- \*Kalliroscope
- \*Cloud Studies in Colour
- 10 \*Laws of Form
- \*Tao Teh King
- 11 On Growth and Form  
Sciences of the Artificial
- 12 \*Human Condition  
Human Use of Human Beings  
Human Use of the Earth
- 13 \*Man & His Symbols
- \*King and the Corpse
- \*The Unexpected Universe
- 14 \*Technics and Civilization
- \*Age of Discontinuity
- \*The Step to Man
- 15 Process and Pattern in Evolution  
Man Adapting  
The Phenomenon of Man
- 16 The Year 2000  
Futurist
- \*View from the Barrio
- 17 Times Atlas of the World  
World from Above  
Synthesis of Form  
Ghost in the Machine  
Dover Publications  
Psychological Reflections  
Purposive Systems  
Tantra Art  
A Year From Monday  
General Systems Yearbook

## Shelter and Land Use

- 18 \*Geodesics
- \*Fuller Patents  
Space Grid Structures
- 19 Dyna Domes
- \*Zomeworks
- \*Futuro
- 20 \*Design With Nature  
Architecture Without  
Architects
- 21 Tensile Structures, Vols. 1 & 2
- 22 Owner-built Home  
Your Engineered House
- 23 House Carpentry Simplified  
Simplified Carpentry Estimating  
Plumbing and Wiring Books  
National Electrical Codes
- 24 \*Concrete Boatbuilding  
Audel Guides
- 25 \*Plastics in Building
- \*Sweet's Files  
Village Technology
- 26 \*Earth Homes
- \*Yurt  
Wilderness Cabin
- 27 Indian Tipi  
Tipis  
Aladdin Kerosene Lamp

- 28 Man's Role in Changing  
The Face of the Earth  
Two Mushroom Books
- 29 Dome Cookbook  
Architectural Design  
Archigram
- \*Architectural Graphic Standards
- 30 \*Environment
- \*Oceans Magazine
- \*Water in the Service of Man
- \*Oceanography in Print
- \*Sailing Book Service
- 31 \*Low-cost Wood Homes
- \*Wood Products Literature
- \*Concrete Manuals
- \*Blasting
- 32 Seeds and Trees by Mail  
Agricultural Publications
- 33 \*A Modern Herbal  
ABC & XYZ of Bee Culture  
Climates of the States
- 34 \*Organic Gardening & Farming  
Magazine  
Organic Gardening  
Encyclopedia of Organic  
Gardening
- 35 How to Have a Green Thumb  
Soil Test Kit
- \*Goat Husbandry
- \*Pruning Handbook
- \*Rural Industry
- 36 Sundry Materials  
Foam Experiments  
Other Foam Information
- \*Fiberglass
- 37 \*Sealants, caulking
- \*3 Elastic Boat Paints
- \*Plastics
- \*Cement
- \*Membranes
- \*Miscellaneous
- 38 Ashley Thermostatic Stove
- \*New Sources of Energy
- \*Windmills
- \*Sager Weathercaster
- 39 Dymaxion World  
of Buckminster Fuller  
Japanese House  
Fuller Sun Dome  
The Elements Rage  
Wild Foods  
Glue-nailed Roof Trusses  
National Fisherman  
Electricity from the Wind  
Solar Stills

## Industry and Craft

- 40 Way Things Work  
Introduction to Engineering  
Design
- 41 Direct Use of the Sun's Energy
- \*The Design of Design
- 42 New Scientist  
Scientific American  
Product Engineering  
Popular Science
- 43 Popular Mechanix Projects  
Clearinghouse
- \*Science
- 44 Science and Civilization  
in China  
Human Engineering Guide  
Thomas Register of  
Manufacturers
- 45 Handbook of Chemistry and  
Physics  
Machinery's Handbook
- 46 Silvo Hardware  
Surplus Center  
Brookstone Tools  
Jensen Tools
- 47 \*U. S. General Supply
- \*Airborne Sales  
Gerstner Tool Chests  
Snap-on Tools
- 48 \*Government Product News
- \*Tamco Plastic Supplies  
Meccano
- \*Defender Industries
- \*Loctite Technology
- \*Unistrut
- 49 Knots  
Zone System Manual
- 50 \*Unicorn Craft Books  
Craft & Hobby Book Service
- \*Museum of Early American  
Tools
- \*Book of Country Crafts
- 51 Allcraft Tool & Supply  
Woodcraft Supply
- \*Arts and Crafts
- \*Constantine's Wood Catalog
- \*Frank Mittermeier

- 52 \*Pottery
- \*Potter's Wheels
- 53 \*Metal Techniques for  
Craftsmen
- \*Saunders Casting Equipment
- \*Gem Guild
- Adhesive Products
- 54 Macramé
- \*Dye Plants & Dyeing  
Complete Book of  
Progressive Knitting
- \*Indian Spinner
- 55 Techniques of Rug Weaving  
LeClerc Loom  
Pioneer Loom
- \*Condon Yarn  
CUM Yarn
- 56 \*Naz-Dar Silk Screen
- \*Indiacraft
- \*Basketry
- Buckskin
- \*How to Make Cowboy  
Horse Gear
- \*Modern Art of Candle Creating
- 57 How to Build  
Your Own Furniture  
Model & Allied Publications  
Creative Glass Blowing  
Whittling & Woodcarving  
New Science of Strong Materials  
Classic Guitar Construction  
Plastics

## Communi- cations

- 58 \*Natural Way to Draw
- \*Mapping
- 59 \*The Photograph
- \*Diagrams
- 60 Intelligent Life in the Universe  
Cybernetic Serendipity
- 61 Understanding Media  
Cybernetics
- 62 \*Technicians of the Sacred
- \*By the Late John Brockman
- 63 \*Number Words &  
Number Symbols
- \*A Study of Writing
- \*Language of Space
- \*Short-cut Shorthand
- 64-65 Mathematics
- 66 \*Economic Analysis
- \*Supply & Demand
- \*Fortune
- \*Wall Street Journal
- \*Curta Calculator
- 67 Design for a Brain  
Information
- \*Handbook of  
Mathematical Functions  
Desk-top Calculators
- 68 \*Art and Illusion
- \*Tres Riches Heures
- \*Brain Storms
- 69 Eye and Brain
- \*Physical Control of the Mind
- 70 American Cinematographer  
Technique of Documentary  
Film Production  
American Cinematographer's  
Manual
- Behrend's Book
- 71 Techniques of Television  
Production
- Film Making in Schools
- 72 Moog Synthesizer  
Tape Recorders  
King Karol Records
- \*Horns, Strings & Harmony
- 73 \*Rolling Stone
- \*Improvising Jazz
- 74 Allied Radio  
Heathkit  
Tektronix
- 75 Bookmaking
- \*Blackwell's Books
- \*Internews  
American Booksellers  
Association
- \*Wittenborn Books
- 76 \*Simon's Directory  
Subject Guide to  
Books in Print
- Art prints
- 77 Mind of the Dolphin  
Model of the Brain  
Data Study  
McBee Keysort System  
Music by Computers  
Colour Guitar  
Radio Amateur's Handbook

## Com- munity

- 78 Foods by Mail
- \*Perma-Pak  
Lee Electric Flour Mill  
Corona Hand Mill
- 79 \*Joy of Cooking
- \*Impoverished Students' Book  
of Cookery
- Ball Blue Book
- \*Quantity Recipes  
Zen Macrobiotic Cooking
- 80 \*Earth Flag
- \*Vocations for Social Change
- \*Manual of Simple Burial
- \*Moonlighter's Manual
- 81 Modern Utopian
- \*Wildcrafters  
Realist
- Green Revolution
- 82 Boffing Equipment
- \*Kama Sutra Oil
- \*Trimcomb
- \*Handbook of  
Prescription Drugs
- 83 Sauna  
Massage
- 84 Dear Dr. Hippocrates  
The Merck Manual
- 85 Emergency Medical Guide
- \*A Manual for Rural Midwives
- 86 \*The New Childbirth
- \*Preparation for Childbearing
- \*How to Adopt a Child
- \*Womanly Art of Breastfeeding
- \*Happy Baby Food Grinder
- 87 Consumer Reports
- \*Birth Control Handbook
- \*Snugli Baby Carrier
- 88 Champagne Living on a  
Beer Budget
- Unity Buying Service
- Sears/Wards Mail Order
- 89 Armchair Shopper's Guide  
Government Publications
- 90 Federal Domestic Assistance  
Surplus Defense Supply
- 92 Village Planning in the  
Primitive World
- Kibbutz  
The Office
- 93 \*Atlas Shrugged
- \*The Effective Executive
- \*Handbook for  
Conscientious Objectors
- 94 \*How To Live On Nothing
- \*Gestalt Therapy Verbatim
- \*Earth House Hold
- 95 Dune  
Politics of the Barrios  
Synectics  
Person to Person  
Tools for Progress  
Natural Foods Cookbook

## Nomadics

- 96 Complete Walker  
Camping and Woodcraft
- 97 \*Notes on Nomad Equipment
- \*Chouinard Equipment
- \*Mountaineering
- \*Summit
- \*Mountaineering Medicine
- 98 Lightweight Camping  
Equipment
- \*Frostline Outdoor Equipment
- L. L. Bean
- 99 Ski Hut  
Sierra Designs  
Recreational Equipment
- 100 \*Warmite Tent
- \*Eddie Bauer
- \*Camp & Trail
- \*Thomas Black
- \*Barbour
- \*Kelty Pack
- 101 \*Herter's Catalog
- \*The Smilie Co.  
Haverhill's
- 102 Book of Survival  
Survival Book
- \*At Home in the Wilderness  
Innovator
- 103 \*Horses
- \*Practical Western Training
- \*King Solomon's Ring
- \*First Aid Hints for the  
Horse Owner
- Troutfishing in America
- 104 Motor Trend Repair Manual  
Volkswagen Technical Manual  
Truck Repair Manual  
J. C. Whitney

- 105 \*Roadside Camping
- \*BMW Motorcycle
- \*Jawa Motorcycle
- Airstream Trailer
- 106 \*Piloting, Seamanship &  
Small Boat Handling
- American Practical Navigator
- Boat Owners' Guide
- Sailing Illustrated
- \*Skin and Scuba Diving
- \*Handy Medical Guide
- \*Ocean Living
- 107 Stick and Rudder
- \*Used Plane Buying Guide
- \*Air Almanac
- Aeronautical Charts
- Private Pilot's Handbook
- Hot Springs
- 108 National Geographic
- \*U.S.G.S. Topographic Maps
- Explorers Trademart Log
- Hitch-hiking in Europe
- 109 \*New Horizons World Guide
- \*Travelers' Directory
- \*International Atlas
- \*Reference Guide for Travelers

## Learning

- 110 Dr. Spock  
Creative Playthings
- \*Community Playthings  
How Children Learn
- 111 \*The Lives of Children
- \*Hooked on Books
- \*Dibs  
Teacher
- Push Back the Desks
- 112 Cuisenaire Rods  
Programmed Reading  
Initial Teaching Alphabet
- 113 \*I Know a Place  
Creative Drawing
- \*Looking and Seeing
- 114 Thinking Straighter
- \*Jackdaws
- \*Musical Instruments Made  
to be Played
- Encyclopedias  
Media & Methods
- 115 WFF n PROOF  
Educator's Guide to Free Films  
Index to 16 mm  
Educational Films
- Krazy Leg
- \*Things a School Needs
- 116 This Magazine is About Schools  
Teaching as a  
Subversive Activity
- \*New Schools Exchange
- \*Thinking About Using Pot
- 117 Outward Bound  
Education Automation
- \*Humanitas Systems
- Kaiser Aluminum News
- 118 LIFE Science Library
- 119 700 Science Experiments  
Edmund Scientific
- \*Elementary Science Study
- 120 \*Patterns of Survival
- \*Follow Through Project
- \*Web of Life
- \*Andrew Lang Fairy Books
- Guinness Book of  
World Records
- 121 Self-hypnosis  
The English Duden  
Scientific American Offprints  
Paper Airplane Book  
Introduction to Scientific Research  
Using Libraries Effectively  
Sense Relaxation
- 122 Fundamentals of Yoga  
Lucis Trust Library  
Meditation Cushions & Mats
- \*Man's Presumptuous Brain
- 123 Yaqui Way of Knowledge  
Altered States of Consciousness
- 124 \*Plans and the Structure of Behavior
- \*Five Ages of Man
- 125 Act of Creation  
I Ching
- 126 Advertisements
- 127 CATALOG costs  
Suggestion Form
- 128 Whole Earth Truck Store  
Distributors  
Subscription Form
- 129 Portola Institute

# CATALOG Procedure



## Ordering from the CATALOG

Address orders to the supplier given with the item (unless you know of a better one; if you do, let us know).

If the price listed is not 'postpaid', consult post office or express agency for cost of shipping from supplier's location to yours.

Add state sales tax if transaction is within your state. (California sales tax is 5%.)

Send check or money order with your order.

Blank order envelopes are provided at the back of the CATALOG for your convenience and so that suppliers have some idea of the CATALOG's effect on their business.

If the supplier gives you poor service, let us know. That information can be added to his review.

With some indicated items the CATALOG also will ship. There is no price difference with the service; the CATALOG gets the markup instead of the other guy, is all. Our service is fairly fast, especially for west coast orders. Bear in mind there's an inflation on. Prices are subject to rise without notice.

Generally, the closer the supplier is to you, the quicker and cheaper the shipping will be. If the item you're getting is delicate or if you are in a hurry, air express is a good deal. Anything overseas do by air, unless you want to wait a month or so for delivery.

## Subscribing to the CATALOG

\$8.00 per year. This includes fall and spring issues of the CATALOG and four Supplements. Subscription forms are at the back. Memorize your zip code. If your address changes, you must tell us, because the Post Office won't forward.

## Suggesting and Reviewing

The validity of the information in the CATALOG is only as good as the transmitted experience of users. What would you add to the current CATALOG?

The CATALOG pays its reviewers \$10 an item for: getting familiar with the item, its usefulness, and its competition; evaluating the item; selecting samples of graphics or text (with page references) for the review; writing a 100-300 word review. Reviewers and first-suggestors of items are credited in the CATALOG.

We invite reviews that improve on present reviews or accompany suggestions for new items. On acceptance for CATALOG publication reviewers are paid \$10 per accepted review. Unused reviews are not returned. Appearance of submitted material doesn't matter unless it is meant to be camera-ready.

## Supplement

Commentary from CATALOG users that is of general interest is published in the Supplement. Critical comments, new design processes, no-cash techniques, news of specific enterprises, useful fantasies, design student work, time and trouble shortcuts, new uses for common or exotic materials, other realms for the CATALOG to consider, &c., &c., — welcome.

Some tentative item reviews are carried in the Supplements without payment to the reviewer. If a Supplement review is later carried in the CATALOG the reviewer is paid then.

## Donating

Portola Institute, Inc. is a tax-exempt, non-profit educational corporation. Donations to Portola or the CATALOG may be deducted. Retaining subscriptions to the CATALOG are \$25 for one year (\$17 tax deductible). Sustaining subscriptions are \$100+ per year (\$92+ tax deductible). Names of retaining and sustaining subscribers are given in the CATALOG.

## Gifts and Informal Resale

CATALOGs and Supplements are available in quantities of 5 or more at 25% discount. Thus you can get 5 CATALOGs for \$15, sell four, keep one, and come out \$1 ahead. There is no quantity discount on subscriptions.

For formal resale, see p. 128.

## Advertising

Suppliers, manufacturers, creators of listed items are eligible to advertise in the CATALOG. They may advertise only an item listed or their own catalog. All ads are placed at the back of the book. There are no ads in the Supplement.

Advertising rates:

full page \$200	\$75	full page 10" x 14 1/2"
	\$25	1/2 page 10" x 7"
	\$10	1/4 page 5 1/2" x 7"
	\$5	1/8 page 5 1/2" x 3 3/8"
		1/16 page 2 1/2" x 3 3/8"

## CATALOG Policy with Suppliers and Users

The CATALOG is under no obligation to suppliers. Users are under no obligation to the CATALOG.

Suppliers (manufacturers, creators, etc.) may not buy their way into the CATALOG. Free samples, etc. are cheerfully accepted by CATALOG researchers; response not predictable. No payment for listing is asked or accepted. We owe accurate information exchange to suppliers, but not favors.

Our obligation is to CATALOG users and to ourselves to be good tools for one another.

**This issue** of the CATALOG (new? improved?) has higher efficiency production behind it. Produced in three weeks by five people plus help. New uptown printer for new big-time scale of readership. Same old homey distribution. This CATALOG was put together by:

Stewart Brand	with (reviewers)	Sarah Kahn	Ruth Rutherford
Joe Bonner	Jay Baldwin	Johan Mathiesen	Pat Rowan
Cappy McClure	Drew Langsner	Ken Kern	John Holt
Fred Richardson	Jane Stallings	Richard Raymond	Beatrice Farrar Ryan
Jay Bonner	Gurney Norman	David Noton	Carl Mueller
Diana Shugart	C. P. Christianson	Michael Templeton	David & Lyn Roessler
Lloyd Kahn	Steve Katona	Larry Kafka	Jur Bekker
Mary McCabe	Carol Goodell	Terry Bisson	
	Peter Lynn Sessions	Don Gerrard	
	Carole Beadle	Mrs. W. B. Mohin	
and (store)	ONYX	Larry Schwartz	
Hal Hershey	Keith Britton	Lora Ferguson	
Lois Brand	Haru Bekker	Craige Schensted	
Peter Ratner	Michael S. Kaye	Mary Jane Markley	
Tracy McCallum	Steve Baer	Alan Schmidt	
Bernie Sproch	Brooke Elgie	Roberta Becker Marshall	
Megan Raymond			

Preparation of the CATALOG was done on an IBM Selectric Composer, Polaroid MP-3 camera, and Stat-King camera. Printing by Stecher-Traung-Schmidt, San Francisco.

The WHOLE EARTH CATALOG and Difficult But Possible Supplement is published at Portola Institute, 558 Santa Cruz, Menlo Park, California 94025 on the following schedule:

CATALOG — November	CATALOG — May
<u>Supplement</u> — January	<u>Supplement</u> — July
<u>Supplement</u> — March	<u>Supplement</u> — September

# Whole Systems

Buckminster Fuller

*The insights of Buckminster Fuller initiated this Catalog.*

Among his books listed here, his most recent is probably the best introduction—it's a succinct summary of what's been on his mind for many a year and what's on his mind now: how mankind may hatch and survive the hatching. An Operating Manual for Spaceship Earth.

Of the other, larger, books, *Nine Chains to the Moon* is his earliest and most openly metaphysical, *The Unfinished Epic of Industrialization* the most beautiful, *Ideas and Integrity* his most personal, *No More Secondhand God* the most generalized, *World Design Science Decade* (co-authored with John McHale) the most programmatic.

People who beef about Fuller mainly complain about his repetition—the same ideas again and again, it's embarrassing. It is embarrassing, also illuminating, because the same notions take on different uses when re-approached from different angles or with different contexts. Fuller's lectures have a raga quality of rich nonlinear endless improvisation full of convergent surprises.

Some are put off by his languages, which makes demands on your head like suddenly discovering an extra engine in your car—if you don't let it drive you faster, it'll drag you. Fuller won't wait. He spent two years silent after illusory language got him in trouble, and he returned to human communication with a redesigned instrument.

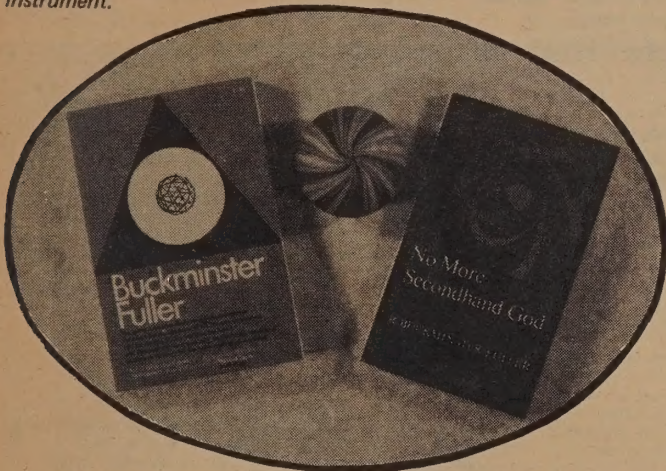

**Ideas and Integrity**  
Buckminster Fuller  
1963; 318 pp.

**\$1.95** postpaid

from:  
Collier Books  
The MacMillan Company  
Order Dept  
Front and Brown Streets  
Riverside, N. J. 08075

or WHOLE EARTH CATALOG

**No More Secondhand God**  
Buckminster Fuller  
1963; 163 pp.

**\$2.25** postpaid

from:  
Southern Illinois University Press  
600 West Grand  
Carbondale, Illinois 62903

or WHOLE EARTH CATALOG

You belong to the universe. The significance of you will forever remain obscure to you, but you may assume that you are fulfilling your significance if you apply yourself to converting all your experiences to highest advantage of others. You and all men are here for the sake of other men.

I define "synergy" as follows: Synergy is the unique behavior of whole systems, unpredicted by behavior of their respective sub-systems' events.  
[Ideas and Integrity]

Thinking is a putting-aside, rather than a putting-in discipline, e.g., putting aside the tall grasses in order to isolate the trail into informative viewability. Thinking is FM—frequency modulation—for it results in tuning-out of irrelevancies as a result of definitive resolution of the exclusively tuned-in or accepted feed-back messages' pattern differentiability.

["Omnidirectional Halo" No More Secondhand God]

*The World Design Science Decade documents contain some that is in the other books and much that isn't. The 6 volume set costs \$10.50 postpaid to students (formal and informal); \$30.00 postpaid to others. This is a very good deal.*

Order from:  
World Resources Inventory Office  
P. O. Box 909  
Carbondale, Illinois 62901

My Recommendations for a Curriculum of Design Science:

1. Synergetics
2. General Systems Theory
3. Theory of Games (Von Neumann)
4. Chemistry and Physics
5. Topology, Projective Geometry
6. Cybernetics
7. Communications
8. Meteorology
9. Geology
10. Biology
11. Sciences of Energy
12. Political Geography
13. Ergonomics
14. Production Engineering

[WDS Document 5]

We find that original question asking is a consequence of interferences, whether in the computer or the human brain. We find then that original questions are second derivative events in the computer life. [WDS Document 3]



**Operating Manual for Spaceship Earth**  
Buckminster Fuller  
1969; 143 pp.

**\$4.25** postpaid from:  
Southern Illinois University Press  
600 West Grand  
Carbondale, Illinois 62903

or WHOLE EARTH CATALOG

For \$4.95 you can get a paperback called *Environment and Change* which has an identical "Operating Manual" along with 24 other futuristic articles, including fine pieces by R. G. H. Siu, John R. Platt, Herman Kahn, Robert Theobald, Gunnar Myrdal, David Buzelon, and John Turner.

from:  
University of Indiana Press  
P. O. Box 369  
Bloomington, Indiana 47401

or WHOLE EARTH CATALOG

**Nine Chains to the Moon**  
Buckminster Fuller  
1938, 1963; 375 pp.

**\$2.45** postpaid from:  
Southern Illinois University Press  
600 West Grand  
Carbondale, Illinois 62903

or WHOLE EARTH CATALOG

Common to all such "human" mechanisms—and without which they are imbecile contraptions—is their guidance by a phantom captain.

This phantom captain has neither weight nor sensorial tangibility, as has often been scientifically proven by careful weighing operations at the moment of abandonment of the ship by the phantom captain, i.e., at the instant of "death." He may be likened to the variant of polarity dominance in our bipolar electric world which, when balanced and unit, vanishes as abstract unity 1 or 0. With the phantom captain's departure, the mechanism becomes inoperative and very quickly disintegrates into basic chemical elements.

An illuminating rationalization indicated that captains—being phantom, abstract, infinite, and bound to other captains by a bond of understanding as proven by their recognition of each other's signals and the meaning thereof by reference to a common direction (toward "perfect")—are not only all related, but are one and the same captain. Mathematically, since characteristics of unity exist, they cannot be non-identical.

Since Yogi is a personalized art, the art dies with the person. The abstract power involved remains as real and true, always, but it cannot be made utilizable in increasing continuity for the world in general. Christ and his counterparts realized this and were unique in their refusal to apply this power to self ends. It was this personal limitation of the Yogi art which led the prosaic philosophers to search further. They sought a means of limitless articulation.  
[Nine Chains to the Moon]

The will of history reads "for everybody or for nobody," and since we balk at "for nobody" it has to be "for everybody." And that's the way it is going, lickety-split and the world around.  
[WDS Document 3]

**Personal Self Disciplining.** In 1927 I gave up forever the general economic dictum of society, i.e., that every individual who wants to survive must earn a living. I substituted, therefore, the finding made in concept one, i.e., the individual's antientropic responsibility in universe. I sought for the tasks that needed to be done that no one else was doing or attempting to do, which if done would physically and economically advantage society and eliminate pain.  
[WDS Document 5]

Reshape environment; don't try to reshape man. [WDS Document 1]

To begin our position-fixing aboard our Spaceship Earth we must first acknowledge that the abundance of immediately consumable, obviously desirable or utterly essential resources have been sufficient until now to allow us to carry on despite our ignorance. Being eventually exhaustible and spoilable, they have been adequate only up to this critical moment. This cushion-for-error of humanity's survival and growth up to now was apparently provided just as a bird inside of the egg is provided with liquid nutriment to develop it to a certain point. But then by design the nutriment is exhausted at just the time when the chick is large enough to be able to locomote on its own legs. And so as the chick pecks at the shell seeking more nutriment it inadvertently breaks open the shell. Stepping forth from its initial sanctuary, the young bird must now forage on its own legs and wings to discover the next phase of its regenerative sustenance.

Brain deals exclusively with the physical, and mind exclusively with the metaphysical. Wealth is the progressive mastery of matter by mind. . . .

A new, physically uncompromised, metaphysical initiative of unbiased integrity could unify the world. It could and probably will be provided by the utterly impersonal problem solutions of the computers.

Possession is becoming progressively burdensome and wasteful and therefore obsolete.

You and I are inherently different and complementary. Together we average as zero—that is, as eternity.  
[Operating Manual for Spaceship Earth]

**The Unfinished Epic of Industrialization**  
Buckminster Fuller  
1963; 227 pp.

**\$4.50** postpaid from:  
Small Publishers Company  
276 Park Avenue South  
New York, N. Y. 10010

or WHOLE EARTH CATALOG

However, man unconcernedly sorting mail on an express train with unuttered faith that the engineer is competent, that the switchmen are not asleep, that the track walkers are doing their job, that the technologists who designed the train and the rails knew their stuff, that the thousands of others whom he may never know by face or name are collecting tariffs, paying for repairs, and so handling assets that he will be paid a week from today and again the week after that, and that all the time his family is safe and in well being without his personal protection constitutes a whole new era of evolution—the first really "new" since the beginning of the spoken word. In fact, out of the understanding innate in the spoken word was Industrialization wrought after milleniums of seemingly whitherless spade work.  
[The Unfinished Epic of Industrialization]

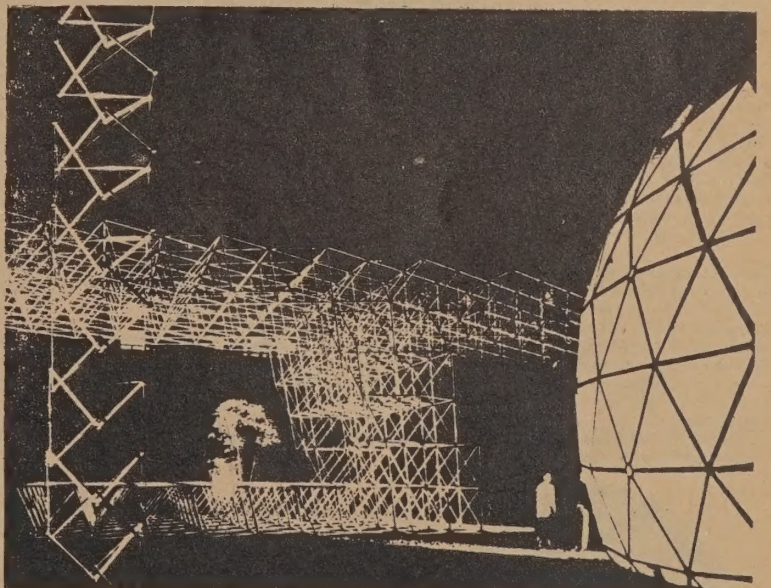

Tension and Compression are complementary functions of structure. Therefore as functions they only co-exist. When pulling a tensional rope its girth contracts in compression. When we load a column in compression its girth tends to expand in tension. When we investigate tension and compression, we find that compression members, as you all know as architects, have very limited lengths in relation to their cross sections. They get too long and too slender and will readily break. Tension members, when you pull them, tend to pull, approximately (almost but never entirely), straight instead of trying to curve more and more as do too thin compressionally loaded columns. The contraction of the tension members in their girth, when tensionally loaded, brings its atoms closer together which makes it even stronger. There is no limit ratio of cross section to length in tensional members of structural systems. There is a fundamental limit ratio in compression. Therefore when nature has very large tasks to do, such as cohering the solar system or the universe she arranges her structural systems both in the microcosm and macrocosm in the following manner. Nature has compression operating in little remotely positioned islands, as high energy concentrations, such as the earth and other planets, in the macrocosm; or as isolated electrons, or protons or other atomic nuclear components in the microcosm while cohering the whole universal system, both macro and micro, of mutually remote, compressional, and oft non-simultaneous, islands by comprehensive tension;—compression islands in a non-simultaneous universe of tension. The Universe is a tensegrity.  
[WDS Document 2]

## The Population Bomb

*There's a shit storm coming. Not a nice clean earthquake or satisfying revolution but pain in new dimensions: world pain sub-continents that starve and sub-continents that eat unable to avoid each other. The consequences will dominate our lives. In the heart of the problem are the solutions, and the sooner we're clear about what's happening the sooner the solutions can work their way out. This book is the best first hard look that's around. The author is a well-regarded young population biologist and ecologist who freaked out of his lab and into the media with the bad news. Besides freaking well he reports well.*

### The Population Bomb

Dr. Paul R. Ehrlich  
1968; 223 pp.

**\$.95** postpaid from

Ballantine Books, Inc.  
c/o Simon & Schuster, Inc.  
630 Fifth Avenue  
New York, N. Y. 10020  
or  
WHOLE EARTH CATALOG

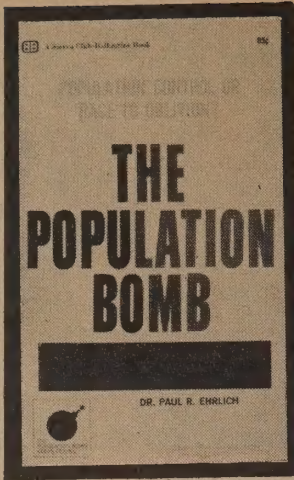

It is, of course, socially very acceptable to reduce the death rate. Billions of years of evolution have given us all a powerful will to live. Intervening in the birth rate goes against our evolutionary values. During all those centuries of our evolutionary past, the individuals who had the most children passed on their genetic endowment in greater quantities than those who reproduced less. Their genes dominate our heredity today.

The reproductive function of sex must be shown as just one of its functions, and one that must be carefully regulated in relation to the needs of the individual and society. Much emphasis must be placed on sex as an interpersonal relationship, as an important and extremely pleasurable aspect of being human, as mankind's major and most enduring recreation, as a fountainhead of his humor, as a phenomenon that affects every aspect of his being

The battle to feed all of humanity is over. In the 1970's the world will undergo famines—hundreds of millions of people are going to starve to death in spite of any crash programs embarked upon now. At this late date nothing can prevent a substantial increase in the world death rate, although many lives could be saved through dramatic programs to 'stretch' the carrying capacity of the earth by increasing food production. But these programs will only provide a stay of execution unless they are accompanied by determined and successful efforts at population control. Population control is the conscious regulation of the numbers of human beings to meet the needs, not just of individual families, but of society as a whole.

Nothing could be more misleading to our children than our present affluent society. They will inherit a totally different world, a world in which the standards, politics, and economics of the 1960's are dead. As the most powerful nation in the world today, and its largest consumer, the United States cannot stand isolated. We are today involved in the events leading to famine; tomorrow we may be destroyed by its consequences.

Remember also that in virtually all underdeveloped countries, people have gotten the word about the better life it is possible to have. They have seen colored pictures in magazines of the miracles of Western technology. They have seen automobiles and airplanes. They have seen American and European movies. Many have seen refrigerators, tractors, and even TV sets. Almost all have heard transistor radios. They know that a better life is possible. They have what we like to call 'rising expectations.' If twice as many people are to be happy, the miracle of doubling what they now have will not be enough. It will only maintain today's standard of living. There will have to be a tripling or better. Needless to say, they are not going to be happy.

A ship has hit the rocks and is sinking. The passengers scream for help. Some jump overboard and are devoured by the circling sharks. A group of distinguished scientists is on board. One of their number suggests that they can help man the pumps. 'Oh, no!' shout the others. 'That might hurt the captain's feelings. Besides, pumping is not our business. It's outside our field of competence.' You can guess what they do. They appoint a committee to study the problem, with subcommittees on marine engineering and navigation. They announce to the passengers that in two or three years the committee will produce a wonderful report which will be acceptable to the passengers, the captain, and the steamship line. Not so passive are the politicians. Some jump up to say that the passengers don't understand the political realities of the situation. Other more progressive politicians grab thimbles and start bailing, stopping every few seconds to accept praise for their valiant efforts.

Careless overuse of DDT has promoted to 'pest' category many species of mites, little insectlike relatives of spiders. The insects which ate the mites were killed by the DDT, and the mites were resistant to DDT. There you have it—instant pests, and more profits for the agricultural chemical industry in fighting these Frankensteins of their own creation. What's more, some of the more potent miticides the chemists have developed with which to do battle seem to be powerful carcinogens—cancer-producing substances.

The old idea that industry could create the mess and then the taxpayers must clean it up has to go. The garbage produced by an industry is the responsibility of that industry.

## Population, Evolution, and Birth Control

*Once you've woken up to the population squeeze and the blindness of most of your fellow men, it's worth looking around. Garret Hardin has assembled a strong selection of eyes to look around with. Here are the ingredients for understanding. Now, how do we get the mule's attention?*

The closed earth of the future requires economic principles which are somewhat different from those of the open earth of the past. For the sake of picturesqueness, I am tempted to call the open economy the 'cowboy economy,' the cowboy being symbolic of the illimitable plains and also associated with reckless, exploitative, romantic, and violent behavior, which is characteristic of open societies. The closed economy of the future might similarly be called the 'spaceman' economy, in which, therefore, man must find his place in a cyclical ecological system which is capable of continuous reproduction of material form even though it cannot escape having inputs of energy.

Kenneth E. Boulding

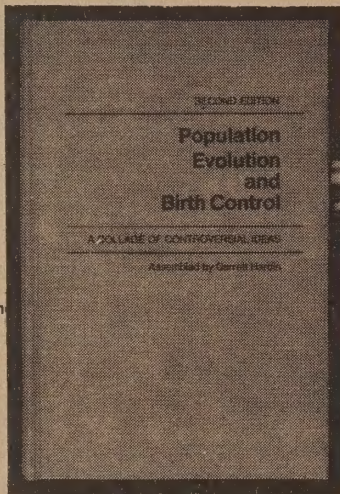

### Population, Evolution, and Birth Control

Garret Hardin, ed.  
1964, 1969; 386 pp.

**\$.295** postpaid

from:  
W. H. Freeman & Co.  
660 Market Street  
San Francisco, CA 94104

or WHOLE EARTH CATALOG

If the food supply is falling short, or a new disease threatens us, inventions to relieve it must be made before famine and pestilence have done their work. Now, we are far nearer to an interruption of the water supply of New York for six hours, and it will show in the death rate. Let the usual trains bringing supplies into the city be interrupted for forty-eight hours, and some people will die of hunger. Every engineer who has to deal with the administration of the public facilities of a great city has been struck with terror at the risks which people are willing to undergo and must undergo every day, and at the complacent ignorance of these risks on the part of his charges....

Norbert Wiener

The rest of the night I lay there sleepless, trapped between the quavering human cry in the night and the cold fact that forced me to know I could not save him or the thousands of others whose cries I could not hear. The next morning they came and told us that the beggar was dead.

Gerald Winfield

## The State of Siege

*Everybody is freaking. Unfocused distress has been the psychic weather of the world for the last couple years, and it's getting worse. C. P. Snow's classic 1968 lecture brings the focus in sharp: too many, too fast.*

[Suggested by Jerry Mander]

In many places and for many purposes, including some of the fundamental human purposes, there are already too many people in the world. Within a generation, there will be far too many. Within two or three generations—unless we show more sense, goodwill and foresight than men have ever shown—there will be tragically too many. So many that the ordinary human hopes will have disappeared. Disappeared irreversibly, perhaps: or at least for so long that we can't imagine how they will emerge again.

Famine will take charge in many countries. It may become, by the end of the period, endemic famine. There will be suffering and desperation on a scale as yet unknown. This suffering will be witnessed—since our communications will be even better—by the advanced countries, whose populations will be living better than they are today. It is hard to imagine the psychological and political conditions which will be created by such a gap. Some of us are lucky who won't have to live in them. Without question, the rich populations will feel they are in a state of siege, sometimes in a literal sense: and it may be that our present unease is a shadow thrown backwards from the future.

To keep before the world its long-term fate. Peace. Food. No more people than the earth can take. That is the cause.

The State of Siege  
C. P. Snow  
1969; 50 pp.

**\$.295** postpaid

from:  
Charles Scribner's Sons  
Vreeland Avenue  
Totowa, N. J. 07512

or WHOLE EARTH CATALOG



## The Second Genesis

*What I like about the threat of total human control in the near future is that it obliges us to figure out fast what we are about. We got the power; here comes the responsibility. Whether you prefer to embrace it, or flee it (some should, for safeguard), or stay trembling where you are, you might as well have some detailed idea of what's looming.*

*This book, by the Science Editor at LIFE, does good journalism on three spooky areas: Refabrication of the Individual; Exploration of Prenativity; Control of the Brain and Behavior.*

*Hypothesis: changes this radical outdistance the laws but not the economy. Control diminishes for governments and increases for consumers. The outlaw area of rapid change. Witness dope.*

Coming: The control of life. All of life, including human life. With man himself at the controls.

Also coming: a new Genesis—The Second Genesis. The creator this time around—man. The creation—again, man. But a new man. In a new image. A whole series of new images. What will the new images be?

They will have to be quite different from the images we have known—the images that have led us to Vietnam, to turbulent racial conflict, to nuclear confrontation, to the threat of a polluted and overpopulated planet.

But all these things have come about—have they not?—with man at the controls, more or less. If he is acquiring awesome new powers—and he is—with immeasurably greater controls, does this not accelerate us all, at uncountable G's, toward the inevitable Dead End—a hundred bangs, followed by three billion whimpers?

If we believe so, yes.

But man's new images may offer us surprising alternatives. Their creation will require the energetic projection of the best minds of the race to the farthest reaches of their imaginations.

Futile effort?

Anything but. What we believe about man, what we want for man, will profoundly influence what actually happens to man.

What would you like: Education by injection? A catalog of spare body parts? A larger, more efficient brain? A cure for old age? Immortality through freezing? Parentless children? Custom-ordered body size and skin color? The ability to convert sunlight directly into energy, just as plants do, without utilizing food as an intermediary? Name it, and somebody is seriously proposing it.

In sober scientific circles today, there is hardly a subject more commonly discussed than man's control of his own heredity and evolution. And the discussions seldom leave much doubt that man will acquire this control. It is a matter of when, not if.

The late Dr. J. B. S. Haldane, always intrigued by the bizarre, wrote in 1949: "If King Charles I's or King Louis XVI's head had been stuck within a minute or so [after their executions] on a pump which supplied oxygenated blood to it, it would almost certainly have come around, after half an hour or so, enough to open its eyes and move its lips, and would probably have recovered consciousness. I hope that if I have an inoperable cancer this experiment will be tried on me."

Could anyone ever replace a dead-but-frozen ruler? As billions of people were frozen in every generation, the dead might ultimately own all the property and hold all the important offices. Barring the return of some sort of ancestor worship or a cult of the dead, would the unfrozen population put up with it? With life so overabundant and so easy to produce anew, why should anyone want to go to all the trouble and expense of reviving all that competition? Those piled-up frozen corpses might in fact be fiercely resented. If the planet became desperately overpopulated, with prevailing undernourishment and contempt for life, their very presence might even encourage a drift toward cannibalism.

"There is no doubt," says Richard R. Landers in *Man's Place in the Dybosphere*, "that machines as a group will dominate man as a group, and eventually, individual machines will dominate individual men."

"By dominate I mean control, regulate, restrain, influence, pervade, direct, guide, prescribe, etc., by virtue of superiority in all aspects of tasks demanding a leader."

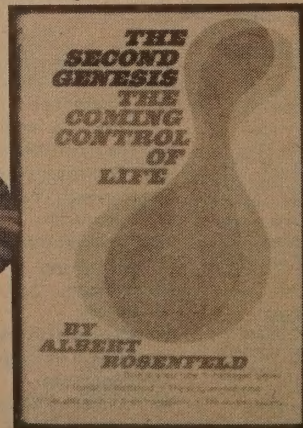

The Second Genesis  
Albert Rosenfeld  
1969; 327 pp.

**\$.695** postpaid

from:  
Prentice-Hall  
Englewood Cliffs  
N. J. 07632

or WHOLE EARTH CATALOG

**★ Science and Survival**

Scientists and technological critics are significantly rare and much needed. Barry Commoner is a good one—prestigious scientist, active administrator, capable writer, committed critic.

Reading his anthology of technological blunders, I am led to wonder if the success of death-fear-driven science merely changes the size of the package that death comes in. There's less of piecemeal local, "natural" dying, and more of massive "caused" dying. I think I prefer the old way. Is anybody working on establishing friendlier relations with Death? Maybe he's a good guy who's had bad press.

[Suggested by Peter Montague]

The trouble began with the failure of a relay which controlled the flow of electricity from the Sir Adam Beck No. 2 power plant in Queenston, Ontario, into one of its feeder lines. The remaining lines, unable to carry the extra load, snuffed their own safety switches. With these normal exits blocked the plant's full power flowed back along the lines that tied the Queenston generators into the U. S. - Canadian grid. This sudden surge of power, traveling across New England, quickly tripped safety switches in a series of local power plants, shutting them down. As a result the New England region, which until then had been feeding excess electricity into the Consolidated Edison system in New York, drained power away from that city; under this strain the New York generators were quickly overloaded and their safety switches shut off. The blackout was then complete. The system had been betrayed by the very links that were intended to save local power plants from failure.

**Science & Survival**  
Barry Commoner  
1966; 150 pp.

**\$1.35** postpaid

from:  
The Viking Press  
625 Madison Avenue  
New York, N. Y. 10022

or **WHOLE EARTH CATALOG**

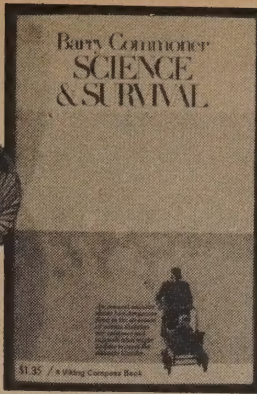

The new hazards are neither local nor brief. Air pollution covers vast areas. Fallout is worldwide. Synthetic chemicals may remain in the soil for years. Radioactive pollutants now on the earth's surface will be found there for generations, and, in the case of carbon-14, for thousands of years. Excess carbon dioxide from fuel combustion eventually might cause floods that could cover much of the earth's present land surface for centuries. At the same time the permissible margin for error has become very much reduced. In the development of steam engines a certain number of boiler explosions were tolerated as the art was improved. If a single comparable disaster were to occur in a nuclear power plant or in a reactor-driven ship near a large city, thousands of people might die and a whole region be rendered uninhabitable—a price that the public might be unwilling to pay for nuclear power. The risk is one that private insurance companies have refused to underwrite. Modern science and technology are simply too powerful to permit a trial-and-error approach.

Meeting under secrecy restrictions, the committee reached the conclusion, which was then made public, that "there is no need for concern regarding any lasting effects on the Van Allen belts and associated phenomena." According to the committee, the explosion's effects on the belts would last "a few weeks to a few months."

On July 9, 1962, still governed by military security, the high-altitude explosion was set off over the Pacific. For some weeks no official information about the results was announced. But despite official silence and the project's military classification, the results of the explosion were soon no more secret than the Van Allen belts themselves. Radioastronomers in Boulder, Colorado, detected on their instruments new radio reflections from the Van Allen belts. These showed that, in the vicinity of the explosion, new zones of atomic particles had been created and that, contrary to the prediction of the government's advisory committee, these were persistent.

Sometimes, in moments of impending crisis, we are aware only that the main outcome of science is that the planet has become a kind of colossal lightly triggered time bomb. Then all we can do is to issue an anguished cry of warning. In calmer times we try to grapple with the seemingly endless problems of unraveling the tangle of nuclear physics, seismology, electronics, radiation biology, ecology, sociology, normal and pathological psychology, which, added to the crosscurrents of local, national, and international politics, has become the frightful chaos that goes under the disarming euphemism "public affairs."

Margaret Mead, the anthropologist, has called scientists' efforts to alert citizens to these issues and provide them with information needed for evaluating the benefits and hazards of modern technology "a new social invention." This may turn out to be the one invention of our technological age which can conserve the environment and preserve life on the earth.

**★ The Subversive Science**



This book has popularity in the underground. Would one of you subversives who's read the book and found it useful please write a considered review for us? All I've done is notice that the book is wide-ranging, intelligently collected, and well presented. And I read Garrett Hardin's essay "Cybernetics of Competition", which is prime goods. There's a lot in the book; I don't want to glance-review it. It points toward ecology as a way of life.

Igloos, tepees, prairie sod-huts, hogans, pueblos—have ecology in their roof-lines.

These shelters for families, like such individual protectors as sunbonnets, sombreros, serapis, are oriented to a landscape, to weather, and to local materials.

The desire to maintain absolute constancy in any system must be recognized as deeply pathological. Engineering theory indicates that excessive restraints can produce instability. In psychiatry also, the desire for complete certainty is recognized as a most destructive compulsion. And in the history of nations, attempts to control rigidly all economic variables have uniformly led to chaos. The psychologically healthy human recognizes that fluctuations are unavoidable, that waste is normal, and that one should institute only such explicit controls as are required to keep each system on its homeostatic plateau. We must devise and use such controls as are needed to keep the social system on the homeostatic plateau. On this plateau—but not beyond it—freedom produces stability.

One of the greatest of the technical social inventions of ancient Athens was that of ostracism, which was invented by Cleisthenes. We are told:

Once a year the popular Assembly deliberated on whether any citizen should be required to go into exile for ten years on the grounds that his presence in Athens was a threat to the constitution. If the Assembly voted to hold an ostracism, a second vote was taken. Then, if six thousand citizens wrote the same name on an ostrakon, or potsherd, the man named must leave Athens for ten years. But he did not lose his citizenship, his goods were not confiscated, he did not even suffer disgrace. In fact, it was only the man of great ability who was likely to be ostracized, yet the possibility of ostracism was a constant deterrent to overwhelming political ambition.

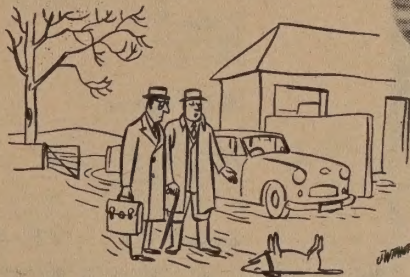

"This is the dog that bit the cat that killed the rat that ate the malt that came from the grain that the jack sprayed." (Reproduced by permission of Punch.)

When we think in terms of systems, we see that a fundamental misconception is embedded in the popular term "side-effects" (as has been pointed out to me by James W. Wiggins). This phrase means roughly "effects which I hadn't foreseen, or don't want to think about." As concerns the basic mechanism, side-effects no more deserve the adjective "side" than does the "principal" effect. It is hard to think in terms of systems, and we eagerly warp our language to protect ourselves from the necessity of doing so.

Whether you will or not  
You are a King, Tristram, for you are one  
Of the time-tested few that leave the world,  
When they are gone, not the same place it was.  
Mark what you leave.

Perhaps the most serious obstacle impeding the evolution of a land ethic is the fact that our educational and economic system is headed away from, rather than toward, an intense consciousness of land. Your true modern is separated from the land by many middlemen, and by innumerable physical gadgets. He has no vital relation to it; to him it is the space between cities on which crops grow.

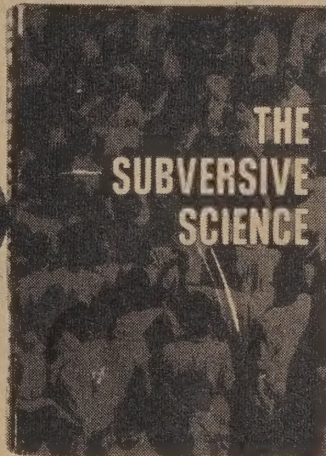
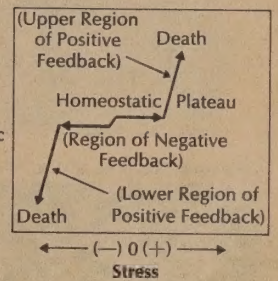

**The Subversive Science—**  
Essays Toward an Ecology  
of Man

Paul Shepard  
Daniel McKinlay, eds.  
1969; 453 pp.

**\$5.95** postpaid

from:  
Houghton Mifflin Co.  
Wayside Road  
Burlington, Mass. 01803

or **WHOLE EARTH CATALOG**

We who were close to the Indians watched the disappearance of boys from public view. Even their father saw them no more. After sometimes a year, sometimes eighteen months, the boys returned—from the underground kivas, from the pathless areas of the Sangre de Cristo range, from the hidden crag where perhaps burns the mystical everlasting fire. Radiant of face, full-rounded and powerful of body, modest, detached: they were men now, keepers of the secrets, houses of the Spirit, reincarnations of the countless generations of their race; with "reconditioned reflexes," with emotions organized toward their community, with a connection formed until death between their individual beings and that mythopoeic universe—that cosmic illusion—that real world—as the case may be, which both makes man through its dreams and is made by man's dreams.

**★ Concepts of Ecology**

There is a crusade called Ecology. And also a science called Ecology. And they're not as distinct as they think they are.

This book is about the science, unhindered by rhetoric. Its subject is energy flow, cycles, populations, ecological communities, and man's place in the system. The emphasis is on theory and observation rather than math. Areas that are still poorly understood get due attention. I wish this book had been around when I studied ecology.

Although the original coining of the term is an uncertainty, there is consensus that the German biologist Ernst Haeckel first gave substance to it in the following statement:

By ecology we mean the body of knowledge concerning the economy of nature—the investigation of the total relations of the animal both to its inorganic and to its organic environment; including above all, its friendly and inimical relation with those animals and plants with which it comes directly or indirectly into contact—in a word, ecology is the study of all the complex interrelations referred to by Darwin as the conditions of the struggle for existence.

The climax community results when no other combination of species is successful in outcompeting or replacing the climax community. In part, this is to be explained by the tolerance limits and optimum requirements inherent in each species.

But stability of the climax is certainly not so simply explained. The answer lies in an as yet not fully understood property—diversity.

**Concepts of Ecology**  
Edward J. Kormondy  
1969; 209 pp.

**\$2.95** postpaid

from:  
Prentice-Hall  
Englewood Cliffs, N. J. 07632

or **WHOLE EARTH CATALOG**

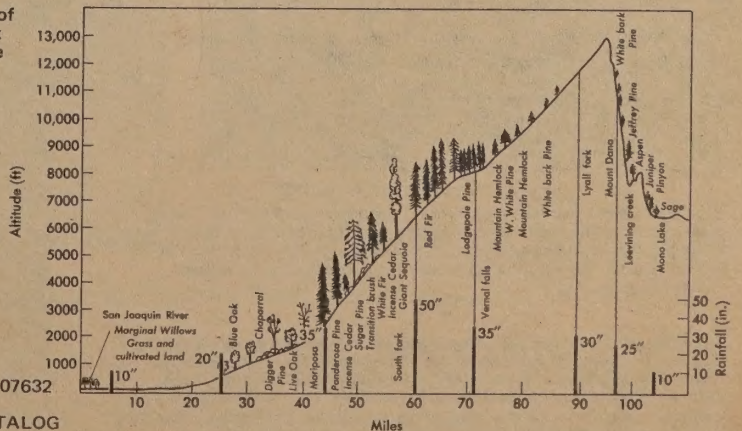
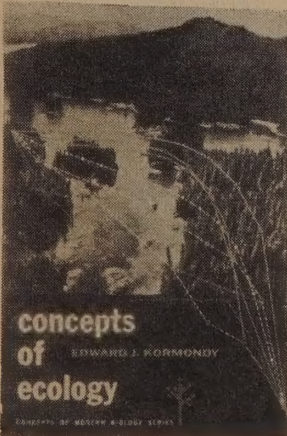

Redrawn, from B. O. Hughes and D. Dunning, 1949. Pine Forests of California. U. S. Department of Agriculture Yearbook.

Fig. 5-2. Profile of central Sierra Nevada showing altitudinal distribution of principal forest types.

**Man's Domain**

*I scarcely believe it. An inexpensive, paperback, lightweight but complete World Atlas that skips all the political planetary persiflage and goes straight to the guts: climate, minerals, agriculture, population, languages, land forms, ocean forms—all the remorseless factors that have been invisible to most of humanity until recently. Nice work, McGraw-Hill, you whipped Rand-McNally and Hammond at their own game.*

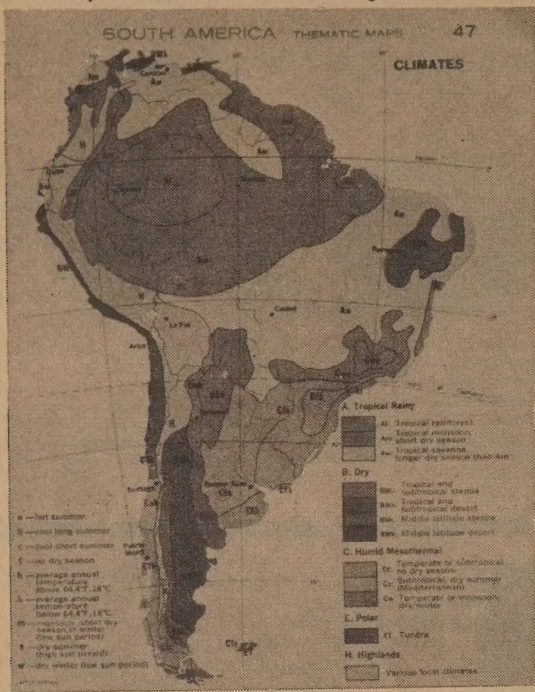

**Man's Domain**  
General Drafting Co.  
1968; 75 pp.  
\$2.75 postpaid

from:  
McGraw-Hill Book Co.  
Princeton Road  
Hightstown, N. J. 08520  
Manchester Road  
Manchester, Mo. 63062  
8171 Redwood Highway  
Novato, CA 94947

or WHOLE EARTH CATALOG

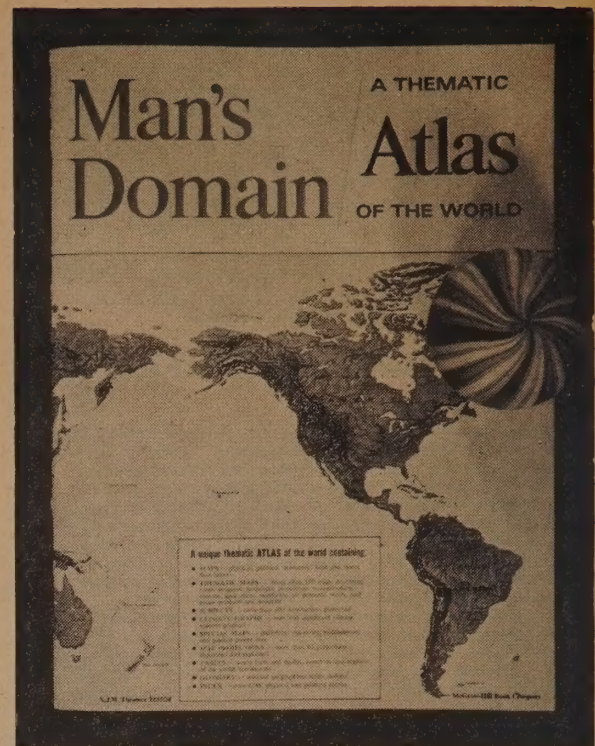

A unique thematic ATLAS of the world containing:  
 • 1000+ political borders, names, and area  
 • 1000+ climate, terrain, and population maps  
 • 1000+ maps of natural resources, minerals, and agriculture  
 • 1000+ maps of languages, land forms, and ocean forms  
 • 1000+ maps of human history and culture  
 • 1000+ maps of world and regional statistics  
 • 1000+ maps of world and regional facts  
 • 1000+ maps of world and regional data

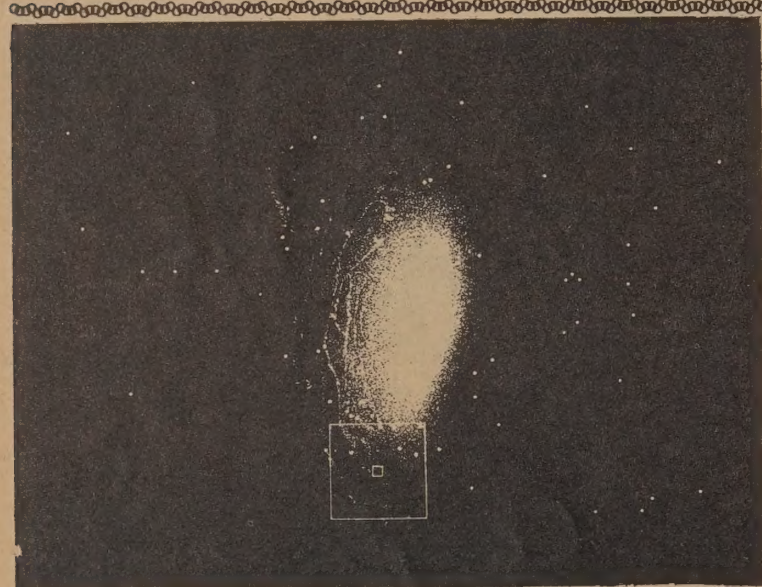

**Cosmic View**

*"The Universe in 40 Jumps" is the subtitle of the book. It delivers.*

*The man who conceived and rendered it, a Dutch schoolmaster named Kees Boeke, gave years of work to perfecting the information in his pictures. The result is one of the simplest, most thorough, inescapable mind blows ever printed. Your mind and you advance in and out through the universe, changing scale by a factor of ten. It very quickly becomes hard to breathe, and you realize how magnitude-bound we've been.*

**Cosmic View**  
Kees Boeke  
1957; 48 pp.

\$4.50 postpaid

from:  
The John Day Company  
62 West 45th Street  
New York, N.Y.

or WHOLE EARTH CATALOG



Though the pronoun "I" now applied to us all collectively, the pronoun "we" also applied to us. In one respect, namely unity of consciousness, we were indeed a single experiencing individual; yet at the same time we were in a very important and delightful manner distinct from one another.

With unreasoning passion we strove constantly to peer behind each minute particular event in the cosmos to see the very features of that infinity which, for lack of a truer name, we had called the Star Maker. But, peer as we might, we found nothing. Though in the whole and in each particular thing the dread presence indubitably confronted us, its very infinity prevented us from assigning to it any features whatever.

"When the cosmos wakes, if ever she does, she will find herself not the single beloved of her maker, but merely a little bubble adrift on the boundless and bottomless ocean of being."

Almost certainly, the star's whole physical behaviour is normally experienced as a blissful, an ecstatic, an ever successful pursuit of formal beauty. This the minded worlds were able to discover through their own most formalistic aesthetic experience. In fact it was through this experience that they first made contact with stellar mind.

We, or rather I, now experienced the slow drift of the galaxies much as a man feels the swing of his own limbs. From my score of viewpoints I observed the great snowstorm of many million galaxies, streaming and circling, and ever withdrawing farther apart from one another with the relentless "expansion" of space. But though the vastness of space was increasing in relation to the size of galaxies and stars and worlds, to me, with my composite, scattered body, space seemed no bigger than a great vaulted hall.

From all the coincident and punctual centres of power, light leapt and blazed. The cosmos exploded, actualizing its potentiality of space and time. The centres of power, like fragments of a bursting bomb, were hurled apart. But each one retained in itself, as a memory and a longing, the single spirit of the whole; and each mirrored in itself aspects of all others throughout all the cosmic space and time.

I said, "It is enough, and far more than enough, to be the creature of so dread and lovely a spirit, whose potency is infinite, whose nature passes the comprehension even of a minded cosmos. It is enough to have been created, to have embodied for a moment the infinite and tumultuously creative spirit. It is infinitely more than enough to have been used, to have been the rough sketch for some perfected creation."

**Star Maker**

*A man's consciousness unwillingly departs his body and his planet. Once in space he accomplishes willed travel in search of Star Maker. His journey takes him into the minds of other planetary beings; a company of these travel together and witness countless civilizations; eventually they participate in a combined consciousness of worlds that in time embraces the stars as well; this leads to galactic and cosmic consciousness and the culminating encounter with Star Maker.*

*Jordan Belson, who I trust in these matters, asserts that it is a true vision, that Stapledon's whole life pointed at attaining it, and that the book will be used and discussed for centuries.*

*This Dover edition has an earlier Stapledon story, Last and First Men, which Jordan considers negligible.*

**Star Maker**  
Olaf Stapledon  
1937; 188 pp.  
\$2.00 postpaid

from:  
Dover Publications, Inc.  
180 Varick Street  
New York, N. Y. 10014

or WHOLE EARTH CATALOG

One night when I had tasted bitterness I went out on to the hill. Dark heather checked my feet. Below marched the suburban street lamps. Windows, their curtains drawn, were shut eyes, inwardly watching the lives of dreams. Beyond the sea's level darkness a lighthouse pulsed. Overhead, obscurity.

The sheer beauty of our planet surprised me. It was a huge pearl, set in spangled ebony. It was nacrous, it was an opal. No, it was far more lovely than any jewel. Its patterned colouring was more subtle, more ethereal. It displayed the delicacy and brilliance, the intricacy and harmony of a live thing. Strange that in my remoteness I seemed to feel, as never before, the vital presence of Earth as of a creature alive but tranced and obscurely yearning to wake.

The sport of disembodied flight among the stars must surely be the most exhilarating of all athletic exercises. It was not without danger; but its danger, as we soon discovered, was psychological, not physical. In our bodiless state, collision with celestial objects mattered little. Sometimes, in the early stages of our adventure, we plunged by accident headlong into a star. Its interior would, of course, be inconceivably hot, but we experienced merely brilliance.

The psychological dangers of the sport were grave. We soon discovered that disheartenment, mental fatigue, fear, all tended to reduce our powers of movement. More than once we found ourselves immobile in space, like a derelict ship on the ocean; and such was the fear roused by this plight that there was no possibility of moving till, having experienced the whole gamut of despair, we passed through indifference and on into philosophic calm.



★ **Andromeda Galaxy**

Superb black and white photograph poster of the nearest galaxy to ours. Peerless meditation target.

[Suggested by Doug Engelbart]

**Andromeda Galaxy**  
26" x 38"

**\$6.00** postpaid

from: **WHOLE EARTH CATALOG**

or **Edmund Scientific**  
100 Edscorp Building  
Barrington, N. J. 08007

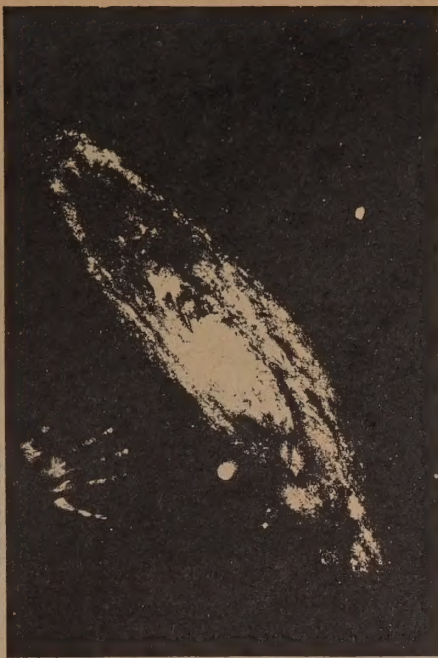

**Earth Photographs**

NASA SP. 129 is a hell of a book. Two hundred forty-three full page color photographs of our planet from the Gemini flights of 1965. If it were a Sierra Club book, and it could be, it would cost \$25. It costs \$7.

There are numerous discoveries in the book. One is that this beautiful place is scarcely inhabited and scarcely inhabitable.

Recently NASA has published a second volume of Gemini pictures. Even better.

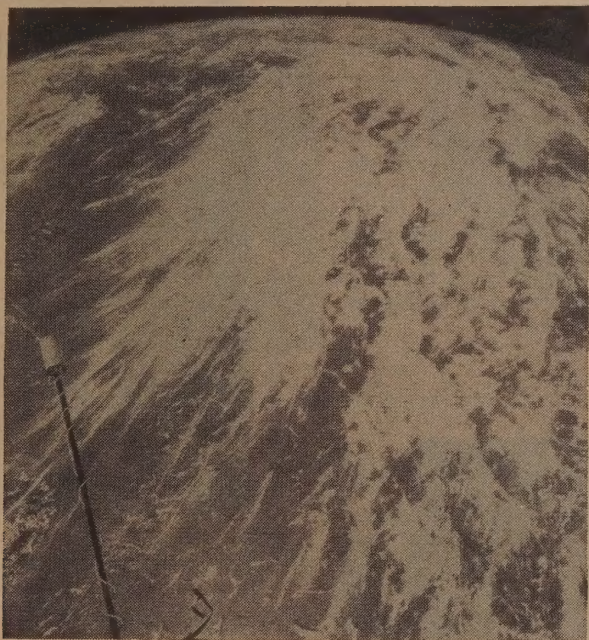

**Full Earth**

Mandala Earth, the high noon color image shot from a synchronous satellite over South America in November 1967, is available as a poster from **WHOLE EARTH CATALOG** for \$2 postpaid. It's the same as the cover of the **Fall '68 CATALOG**, 22"x27". An order of five or more gets 50% discount.

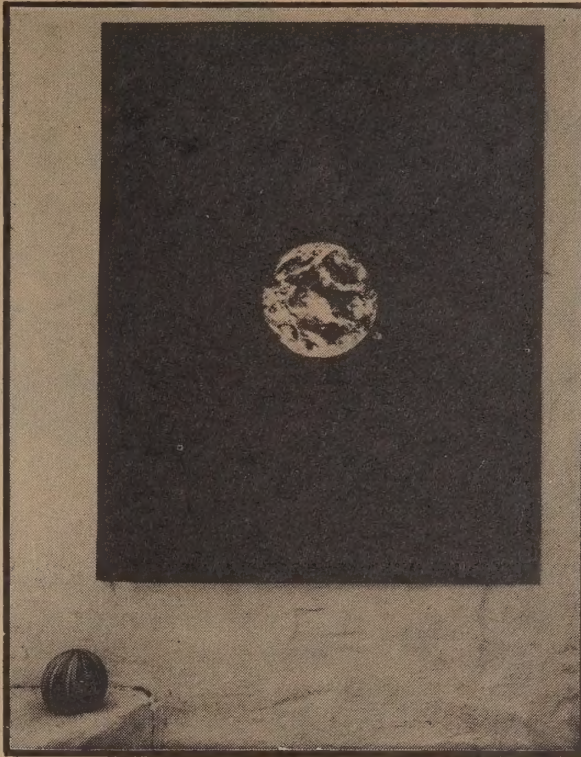

**Whole Earth Rising**

Bigger and better (and costlier—\$3) color photo Earth Posters than ours or Lunar Graphics' come from:

**Celestial Arts**  
1345 Howard Street  
San Francisco, CA

or **WHOLE EARTH CATALOG**

Good ones are: *Earth*  
*Earth from Moon*  
*Astronaut White*

**Earth Photographs from Gemini III, IV, and V.**  
NASA  
1967; 266 pp.

**\$7.00** postpaid

**Earth Photographs from Gemini VI through XII**  
NASA  
1968; 327 pp.

**\$8.00** postpaid

[Suggested by Steve Woodcock]

**Exploring Space With a Camera**  
NASA SP-168 (1968 O-292-583)  
1968; 214 pp.

**\$4.25** postpaid

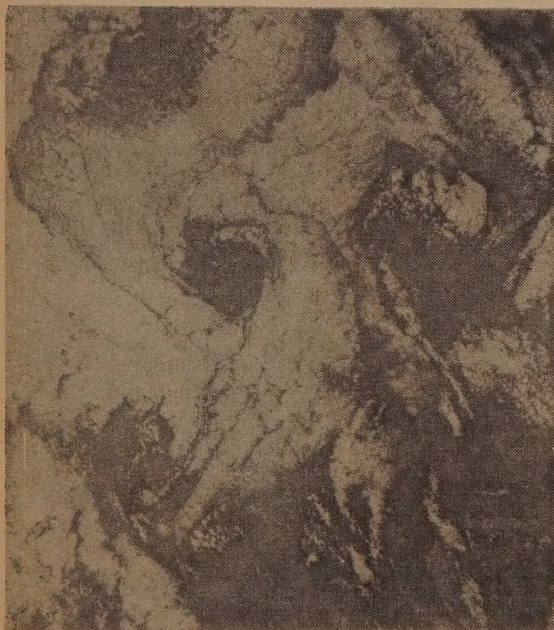

all from:  
U.S. Govt. Printing Office Bookstore  
710 North Capitol Street  
Washington, D. C. 20402

U.S. Govt. Printing Office Bookstore  
Rm. 135, Federal Building  
601 East 12th Street  
Kansas City, Missouri 64106

U.S. Govt. Printing Office Bookstore  
Rm. 1463, 14th Floor  
Federal Office Building  
219 S. Dearborn Street  
Chicago, Illinois 60604

U.S. Govt. Printing Office Bookstore  
Federal Building  
450 Golden Gate Avenue  
Rm. 1023, Box 36104  
San Francisco, California 94102

or **WHOLE EARTH CATALOG**



spread from Earth Photographs

★ **The Observer's Handbook**

For those who like to stare stars straight in the eye, this is the best amateur astronomer's handbook. Asteroids, clusters, constellations, eclipses, galaxies, planets, nebulae, occultations, radio sources, precession, star maps, sun spots, meteors. Published annually in November.

[Suggested by Lee Anderson]

**The Observer's Handbook**  
100 pp.

approx. **\$1.00** from:  
**Royal Astronomical Society of Canada**  
252 College Street  
Toronto 2B, Ontario  
CANADA

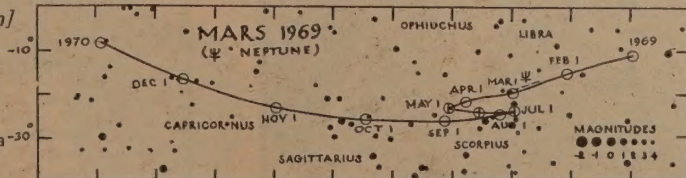

A band of cirrus clouds crosses this picture of the Nile Valley and the Red Sea. "Such cloud bands," says **KENNETH M. NAGLER**, Chief, Space Operations Support Division, Environmental Science Services Administration, "normally occur on the equatorward side of the core of a strong westerly windflow known

as the jetstream, in which winds of 100 knots to occasionally more than 200 knots are common. Often seen in less detail in weather-satellite views, these cirrus bands are particularly useful as indicators of the direction of the upper level wind. In the foreground small cumulus clouds are aligned in rows."

GEMINI XII

**Exploring Space With a Camera**

The Gemini photos books (above) are purer, but this new book of pictures from NASA really is better for understanding the whole systems of Earth, Earth-Moon, and Solar System. All of the outstanding photographs, color and black & white, up through Apollo 7 are here in one family album, with unusually complete information on what can be discovered in the images. It's NASA's bid for your interest in next steps in the real space odyssey. It's convincing.

**Geology Illustrated**

An artist of aerial photography, Shelton uses some 400 of his finest photos to illuminate a discussion of the whole-earth system. Not a traditional textbook, but a fascinating exploration of the problems posed by asking "How did that come about?" Worth buying for the photos and book design alone, but you'll probably find yourself becoming interested in geology regardless of your original intentions.

[Reviewed by Larry McCombs]

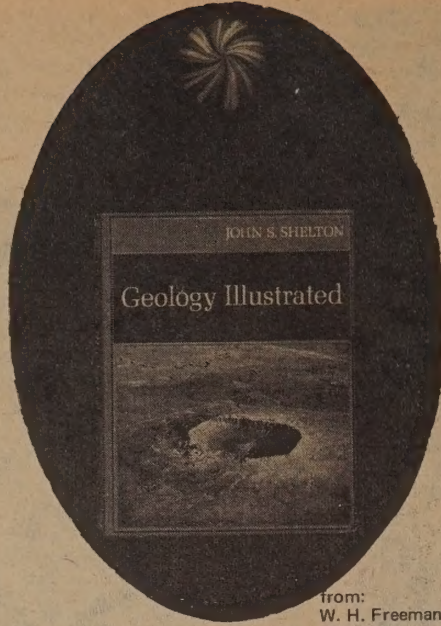

**Geology Illustrated**  
John S. Shelton  
1966; 434 pp.  
**\$10.00** postpaid

from:  
W. H. Freeman & Co.  
660 Market Street  
San Francisco, CA 94104

or **WHOLE  
EARTH  
CATALOG**



**Surface Anatomy**

This book is included as a companion piece to the Earth picture books. The whole lovely system of the human creature, seen from without, surface by surface, is here. One of its main revelations is how cliché ridden our usual views of ourselves are—we are still not good with mirrors (satellites were up 10 years before we got a full view of the Earth). Posing friends and neighbors, with a simple light set-up and a 35mm camera, Joseph Royce has shot the most beautiful human album I know.

It also teaches anatomy.

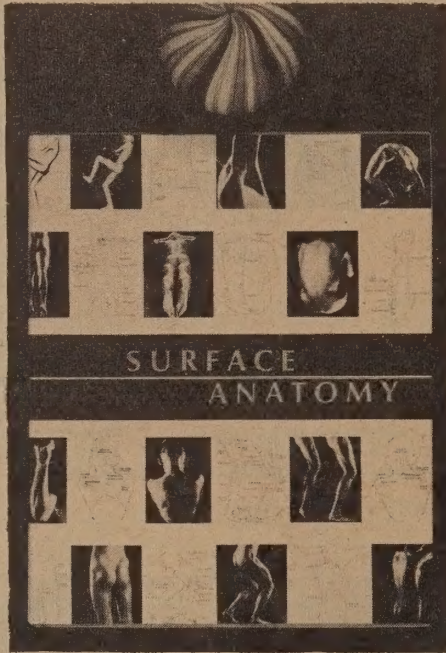

**Surface Anatomy**  
Joseph Royce  
1965; 124 photographs  
and some diagrams

**\$12.50** postpaid

from:  
F. A. Davis Company  
1914 Cherry Street  
Philadelphia, PA 19103

or **WHOLE  
EARTH  
CATALOG**

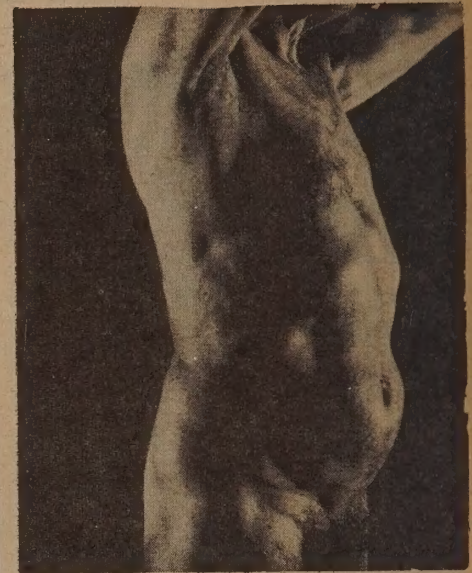

**Structural Integration**

In the mind-body continuum Ida Rolf works on the body and lets the mind come into line behind it. This brief article introduces her approach. What else has Ida Rolf published?

[Suggested by Ed Rosenfeld]

**Structural Integration**

Ida P. Rolf  
1962; 20 pp.

price?

from:  
Ida P. Rolf  
11 Riverside Drive  
New York, N. Y.

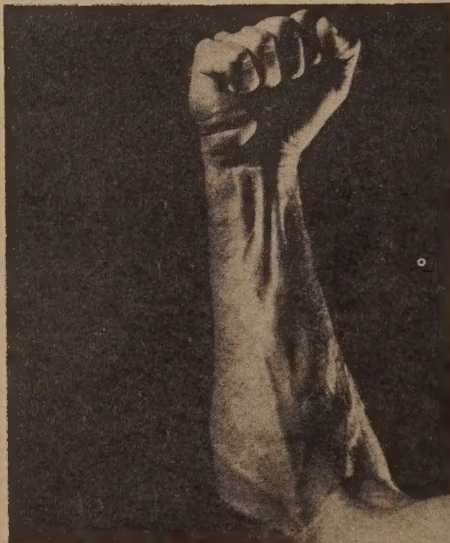

An individual experiencing temporary fear, grief or anger, all too often carries his body in an attitude which the world recognises as the outward manifestation of that particular emotion. If he persists in his dramatization or consistently re-establishes it, thus forming what is ordinarily referred to as a "habit pattern", the muscular arrangement becomes set. Materially speaking some muscles shorten and thicken, others are invaded by connective tissue, still others become immobilized by consolidation of the tissue involved. Once this has happened the physical attitude is invariable; it is involuntary; it can no longer be changed basically by taking thought, or even by mental suggestion. Such setting of a physical response also establishes an emotional pattern. Since it is not possible to express a free flow through the physical flesh, the subjective emotional tone becomes progressively more limited and tends to remain in a restricted and closely defined area. Now, what the individual feels is no longer an emotion, a single response to an immediate situation; henceforth he lives, moves and has his being in an attitude.

It is through the creation of appropriate relationship in three dimensional space that a man may be freed to a higher and more truly human functioning. It therefore becomes imperative that not only must the effect of gravity be studied, but that the structural relations in man be understood in terms of gravity. In this way man will call upon the earth to give him stature, grace and versatility befitting his new knowledge. In short, the earth is the integrating factor which offers him a more human use of his human being.

★  
Cymatics

Take a baggie, tie a few overhand knots in it, hang it up over some water in a dark room and set fire to the bottom. It will gradually burn and melt. The flaming drops go wheep as they fall, and their fiery trail is striped horizontally by the sound vibration. That's down-home cymatics.

Painter Hans Jenny, influenced by Rudolf Steiner, has been playing with other vibration display techniques—sand on iron plate, glycerine on membrane, lycopodium powder, iron filings in magnetic field, crystallizing salt, mercury drops, and viscous liquid. The result is a spectacular book of photographs of the shapes that periodicity can take in three dimensions.



**Cymatics**  
Hans Jenny  
1967; 183 pp.

**\$18.50** postpaid

from:  
Shambala Publications, Inc.  
P. O. Box 4336, Sather Gate  
Berkeley, CA 94704

or **WHOLE EARTH CATALOG**

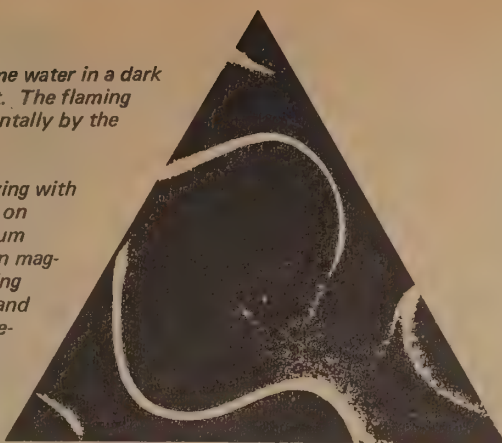

A sonorous figure produced by piezoelectric excitation. The triangle measures 24 cm along each edge. Steel plate. Frequency 875 cps.

Acoustic irradiation transforms the uniform layer of lycopodium powder into a number of round shapes. Each of these rotates on its own axis and at the same time circulates in a constant manner round the whole figure.

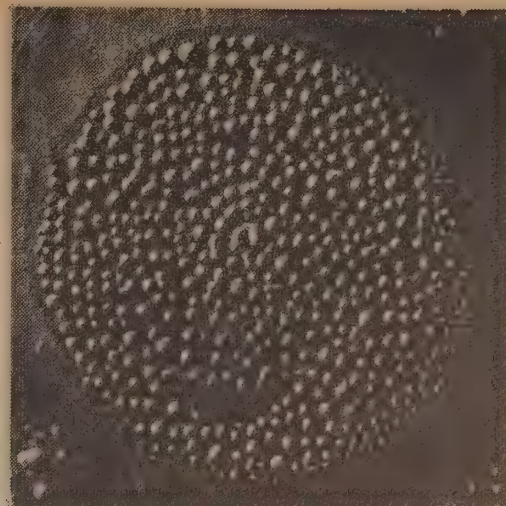

Viscosity changes, with increased amplitude the masses are driven up and shaped like figures. Slight changes of viscosity produce pictures of an entirely different stamp. The figurine seen here must be imagined to be in a state of flow and pulsation.



Sensitive Chaos

Schwenk directs an institute in the Black Forest devoted to the study of the movements of water and air. Within the last few centuries, he says we have "lost touch with the spiritual nature of water." As a result, we have attempted to control the fluids in ways contrary to their nature, and the results are evident in the problems of pollution, damage to the ecosystem, and even drying up of natural water sources. Schwenk attempts to penetrate beyond the mere observable phenomena to an

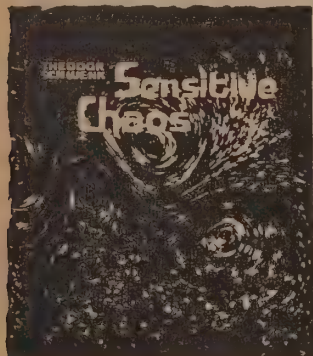

ability to "read" the true spiritual nature of flowing substances.

I found the book to be a peculiarly fascinating mixture of overgeneralization, simplification, undifferentiated fact and theory, and shrewd observation and insight. If you regard analogy as the weakest form of argument, this book is definitely not for you. On the other hand, Schwenk's juxtaposition of similar forms in different flowing media may spark some exciting bisociations, if you are open to them. The section of 88 pages of black and white photos at the back of the book could stand alone as a beautiful art collection.

[Suggested by Lama Foundation.  
Reviewed by Larry McCombs]

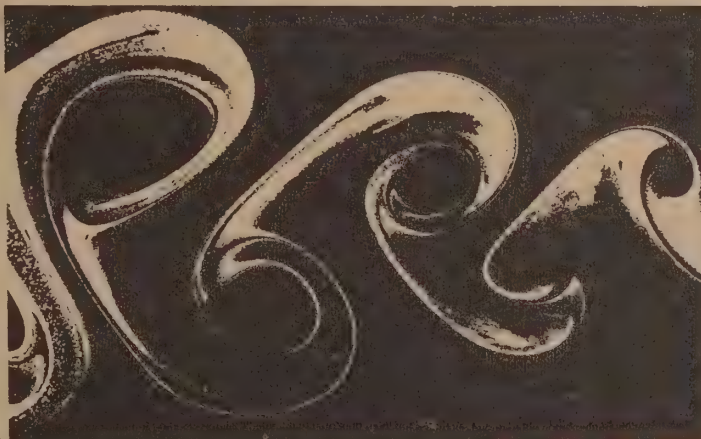

★  
Kalliroscope

Nine square inches of divine turmoil. Rotating on its spinner or cooking on its stand, the Kalliroscope models the action on the surface of the Earth and in all the waves and fires and (probably) in your head.

[Suggested by  
Sandra Tcherepnin]

Kalliroscope

Viewer **\$15**; stand **\$10** postpaid

Available in white, red, yellow, green, blue from:

Paul Matisse  
Kalliroscope Corporation  
145 Mian Street  
Cambridge, Mass. 02142

or **WHOLE EARTH CATALOG**

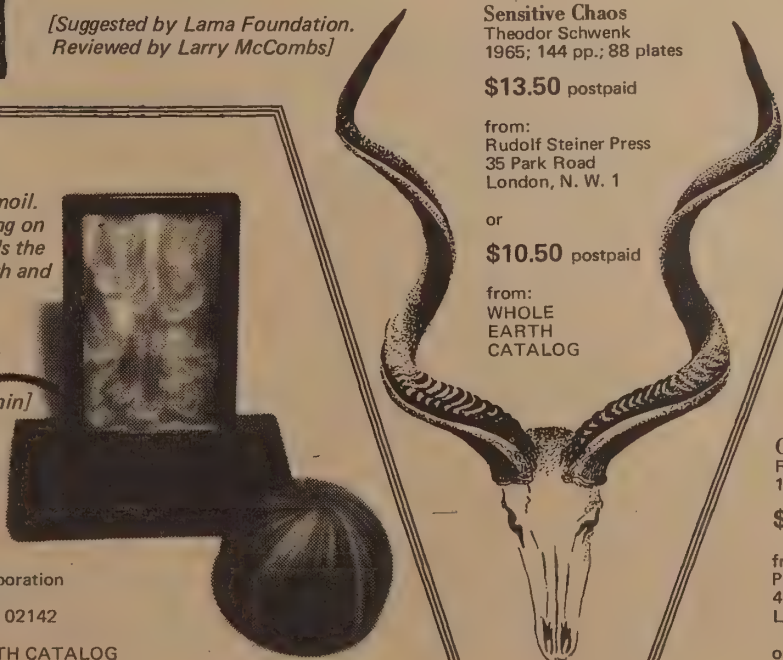

**Sensitive Chaos**  
Theodor Schwenk  
1965; 144 pp.; 88 plates

**\$13.50** postpaid

from:  
Rudolf Steiner Press  
35 Park Road  
London, N. W. 1

or  
**\$10.50** postpaid

from:  
**WHOLE EARTH CATALOG**

★  
Cloud Studies in Colour

If you really don't know clouds at all, there's another side—namely recognition. and knowing what's going on in your part of the atmosphere. This lovely book of color photos and detailed descriptions can help.

**Cloud Studies in Colour**  
Richard Scorer and Harry Wexler  
1967; 44 pp.

**\$7.00** postpaid

from:  
Pergamon Press Inc.  
44-01 21st Street  
Long Island City, N. Y. 11101

or **WHOLE EARTH CATALOG**



★  
Laws of Form

*Jesus Christ. I'm not ready to review this book. Who the hell is? It merely starts over, remakes logic and mathematics from a different beginning, from the Tao's beginning of the prime distinction. It's too simple to grasp. All I can make is the notes at the end of the book, and they keep raising the hair on my head. The book is pure revolution.*

[Suggested by Steve Baer]

Laws of Form  
G. Spencer Brown  
1969; 142 pp.

\$5.40 postpaid

from:  
Blackwell's  
Broad Street  
Oxford, ENGLAND

or WHOLE EARTH CATALOG

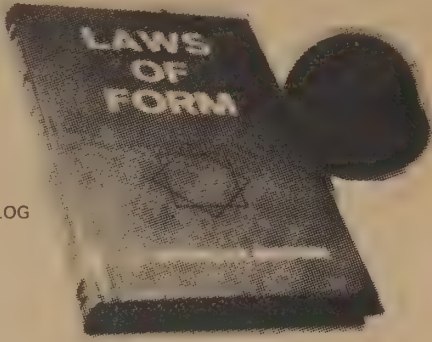

The calculus itself can be realized as a direct recollection. As we left the central state of the form, proceeding outwards and imagewise towards the peripheral condition of existence, we saw how the laws of calling and crossing, which set the stage of our journey through representative space, became fixed stars in the familiar play of time. Our projected hopes and fears of their ultimate atonement, which we called theorems, became their supporting cast. In the end, as we re-enter the form, they are all justified and expended. They were needed only as long as they were doubted, they can be discarded.

It becomes apparent that if certain facts about our common experience of perception, or what we might call the inside world, can be revealed by an extended study of what we call, in contrast, the outside world, then an equally extended study of this inside world will reveal, in turn, the facts first met with in the world outside; for what we approach, in either case, from one side or the other, is the common boundary between them.

CONSTRUCTION  
Draw a distinction.

CONTENT  
Call it the first distinction.  
Call the space in which it is drawn the space severed or cloven by the distinction.  
Call the parts of the space shaped by the severance or cleft the sides of the distinction or, alternatively, the spaces, states, or contents distinguished by the distinction.

INTENT  
Let any mark, token, or sign be taken in any way with or without regard to the distinction as a signal.  
Call the use of any signal its intent.

無名天地之始

Discoveries of any great moment in mathematics and other disciplines, once they are discovered, are accepted as instantly simple and obvious, and make everybody, including their discoverer, appear foolish for having discovered them before. It is all too often forgotten that the ancient symbol for the presentness of the world is a fool, and that foolishness, being a divine state, is not a condition to be either proud or ashamed of.

Unfortunately we find systems of education today which have departed so far from the plain truth, that they now teach us to be proud of what we know and ashamed of ignorance. This is doubly unjust: it is corrupt not only because pride is itself a mortal sin, but also because to teach pride in knowledge is to put up an effective barrier against any advance upon what is already known, since it makes one ashamed to look beyond the bounds imposed by one's ignorance.

To any person prepared to enter with respect into the realm of his great and universal ignorance, the secrets of being will eventually unfold, and they will do so in a measure according to his freedom from natural and indoctrinated shame in his respect of their revelation.

In the face of the strong, and indeed violent, social pressures against it, the simple have been prepared to take this simple and satisfying course towards sanity. And in a society where a prominent psychiatrist can advertise that, given the chance, he would have treated Newton to electric shock therapy, who can blame any person for being afraid to do so?

To arrive at the simplest truth, as Newton knew and practiced, requires years of contemplation. Not activity. Not reasoning. Not calculating. Not busy behaviour of any kind. Not reading. Not talking. Not making an effort. Not thinking. Simply bearing in mind what it is one needs to know. And yet those with the courage to tread this path to real discovery are not only offered practically no guidance on how to do so, they are actively discouraged and have to set about it in secret, pretending meanwhile to be diligently engaged in the frantic diversions and to conform with the dominating postures which are being

In these circumstances, the discoveries that any person is able to undertake represent the places where, in the face of massive opposition, he has, by his own faltering and unaided efforts, returned to sanity, sanity, and even, dangerously, maybe. But nonetheless returned, however furtively.



OR:  
"AXIOM 2: THE LAW OF CROSSING → THE VALUE OF A CROSSING MADE AGAIN IS NOT THE VALUE OF THE CROSSING"  
OR:  
"IN THIS SENSE, IN RESPECT OF ITS INFORMATION, THE UNIVERSE DOES NOT EXPAND TO ESCAPE THE TELESCOPE THROUGH WHICH WE WHO ARE IT, ARE TRYING TO CAPTURE IT."  
THE SNAKE EATS ITS TAIL.  
THE DOG CHASES ITS TAIL.  
OR:  
COMING ACROSS IT, THUS AGAIN, WE SEE THAT OUR JOURNEY WAS, IN ITS PRECONCEPTION UNNECESSARY, ALTHOUGH ITS FORMAL COURSE ONCE WE HAD SET OUT UPON IT WAS INEVITABLE.

QUOTES FROM THE BOOK "LAWS OF FORM" BY G. SPENCER BROWN PUBLISHED BY GEO. ALLEN & UNWIN/455-65.00  
TRUMP CARD ZERO "THE FOOL" FROM A CONTEMPORARY TABLE DECK  
FLOWED OUT FROM LAMA/COOK BOOK FUND - BOX 452 - CORRALES, NEW MEXICO USA #1042 - 60PT 24 PWT

The above is a poster 31" x 23" available for 15¢ postpaid from Lama/Cookbook Fund, Box 422, Corrales, N. M. 87048.

★  
Tao Teh King

*Reviewing the Tao is like reviewing the Bible. As soon as you presume, it just giggles and rains on you. Nevermind.*

*The Tao Teh King is a very old book (500 B.C. is one date) written by a legend named Lao Tzu. It describes how the universe is and makes an excellent case for harmony as the only survival technique that works. This translation by Archie Bahm is straightforward.*

[Suggested by Jack Loeffler]

Tao Teh King  
Lao Tzu; Archie Bahm  
? B.C., 1958; 126 pp.

\$ .85 postpaid

from:  
Frederick Ungar Publishing Co.  
250 Park Avenue South  
New York, N. Y. 10003

or WHOLE EARTH CATALOG



Intelligent control appears as uncontrol or freedom.  
And for that reason it is genuinely intelligent control.  
Unintelligent control appears as external domination.  
And for that reason it is really unintelligent control.

Intelligent control exerts influence without appearing to do so.  
Unintelligent control tries to influence by making a show of force.

Everyone says: "Nature is great, yet Nature is simple."  
It is great because it is simple.  
If it were not simple, long ago it would have come to little.  
Nature sustains itself through three precious principles, which one does well to embrace and follow.  
These are gentleness, frugality and humility.  
When one is gentle, he has no fear of retaliation.  
When one is frugal, he can afford to be generous.  
When one is humble, no one challenges his leadership.  
But when rudeness replaces gentleness,  
And extravagance replaces frugality,  
And pride replaces humility,  
Then one is doomed.  
Since a gentle attack arouses little antagonism,  
And a gentle defense provokes little anger,  
Nature predisposes to gentleness those most suited for survival.

It is because we single out something and treat it as distinct from other things that we get the idea of its opposite. Beauty, for example, once distinguished, suggests its opposite, ugliness.

And Goodness, when we think of it, is naturally opposed to badness.

In fact, all distinctions naturally appear as opposites. And opposites get their meaning from each other and find their completion only through each other. The meanings of "is" and "is not" arise from our distinguishing between them.

Likewise, "difficult and easy," "long and short," "high and low," "loud and soft," "before and after"—all derive their meanings from each other.

Therefore the intelligent man accepts what is as it is. In seeking to grasp what is, he does not devote himself to the making of distinctions which are then mistaken to be separate existences.

In teaching, he teaches, not by describing and pointing out differences, but by example.

Whatever is exists, and he sees that nothing is gained by representing what fully exists by a description—another lesser, diluted kind of existence.

If something exists which cannot be wholly revealed to him with his viewpoint, he does not demand of it that it be nothing but what it seems to him.

If some one else interprets him, he does not trust that interpretation as being equal to his existence.

If some part of him stands out as if a superior representative of his nature, he will not surrender the rest of his nature to it.

And in not surrendering the whole of his nature to any part of it, he keeps himself intact.

This is how the intelligent man preserves his nature.

When government governs little, people are happy.

When government governs much, people are miserable.

Thus happiness depends upon little,

And misery depends upon much.

What does the desire to govern come to?

To restrict interferences is itself interference.

So attempts to increase happiness end only in misery.

Mankind has been foolish for so long a time!

The intelligent man knows what is best, but does not make others conform.

He knows directions, but does not direct.

He pursues the straightest way to the goal, but does not urge others to deviate from their course.

He is enlightened, but he cares not whether others see his light.

**On Growth and Form**

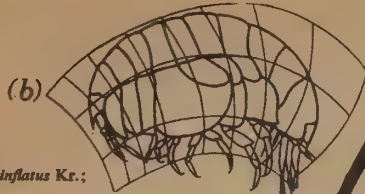
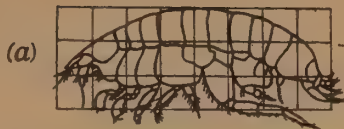

Fig. 143. (a) *Harpinia plumosa* Kr.; (b) *Stegocephalus inflatus* Kr.; (c) *Hyperia galba*.

A paradigm classic. Everyone dealing with growth or form in any manner can use the book. We've seen worn copies on the shelves of artists, inventors, engineers, computer systems designers, biologists. Would one of you do a thorough review of D'Arcy Thompson's venerable book for the CATALOG?

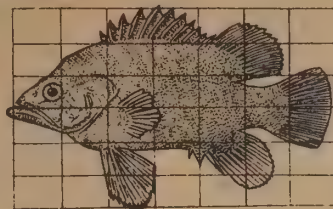

Fig. 150. *Polyprion*.

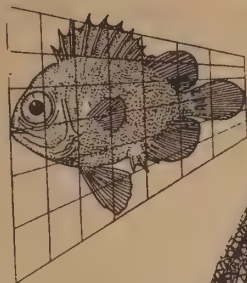

Fig. 151. *Pseudopriacanthus altus*.

When Plateau made the wire framework of a regular tetrahedron and dipped it in soap-solution, he obtained in an instant a beautifully symmetrical system of six films, meeting three by three in four edges and these four edges running from the corners of the figure to its centre of symmetry. Here they meet, two by two, at the Maraldi angle; and the films meet three by three, to form the re-entrant solid angle which we have called a 'Maraldi pyramid' in our account of the architecture of the honeycomb. The very same configuration is easily recognized in the minute siliceous skeleton of *Callimitra*. There are two discrepancies, neither of which need raise any difficulty. The figure is not rectilinear but a spherical tetrahedron, such as might be formed by the boundary edges of a tetrahedral cluster of four co-equal bubbles; and just as Plateau extended his experiment by blowing a small bubble in the centre of his tetrahedral system, so we have a central bubble also here. This bubble may be of any size; but its situation (if it be present at all) is always the same, and its shape is always such as to give the Maraldi angles at its own four corners. The tension of its own walls, and those of the films by which it is supported or slung, all balance one another. Hence the bubble appears in plane projection as a curvilinear equilateral triangle; and we have only got to convert this plane diagram into the corresponding solid to obtain the spherical tetrahedron we have been seeking to explain (Fig. 63).

The geometry of the little inner tetrahedron is not less simple and elegant. Its six edges and four faces are all equal. The films attaching it to the outer skeleton are all planes. Its faces are spherical,



Fig. 63. Diagrammatic construction of *Callimitra*. (a) A bubble suspended within a tetrahedral cage; (b) another bubble within a skeleton of the former bubble.

and each has its centre in the opposite corner. The edges are circular arcs, with cosine  $\frac{1}{2}$ ; each is in a plane perpendicular to the chord of the arc opposite, and each has its centre in the middle of that chord. Along each edge the two intersecting spheres meet each other at an angle of  $120^\circ$ .<sup>1</sup>

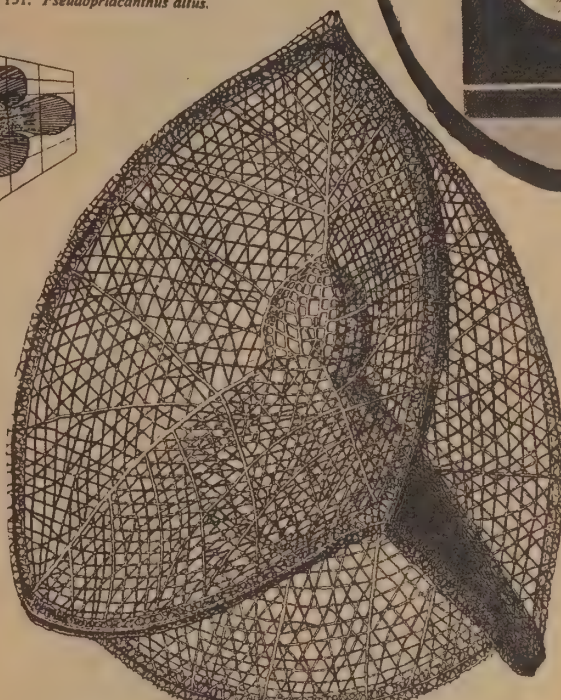

Fig. 62. A Nassellarian skeleton, *Callimitra agnesae* Hkl. (0.15 mm. diameter)

The engineer, who had been busy designing a new and powerful crane, saw in a moment that the arrangement of the bony trabeculae was nothing more nor less than a diagram of the lines of stress, or directions of tension and compression, in the loaded structure: in short, that Nature was strengthening the bone in precisely the manner and direction in which strength was required; and he is said to have cried out, 'That's my crane!'

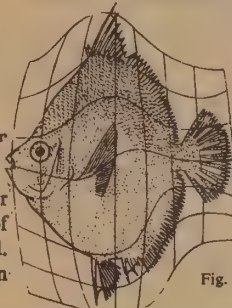
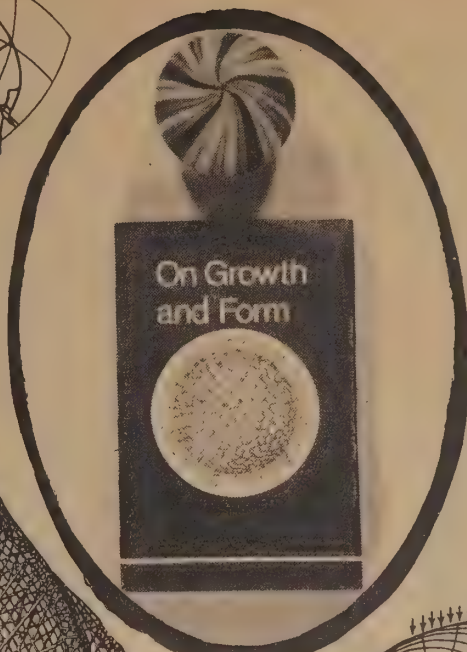

Fig. 153. *Antigonia capros*.



**On Growth and Form**  
D'Arcy Wentworth Thompson  
Two volume edition  
1917, 1952

**\$27.50** postpaid (Currently out of print)

Abridge paper edition  
1917, 1961; 346 pp.

**\$2.75** postpaid

from:  
Cambridge University Press  
510 North Avenue  
New Rochelle, N. Y. 10801

or WHOLE EARTH CATALOG

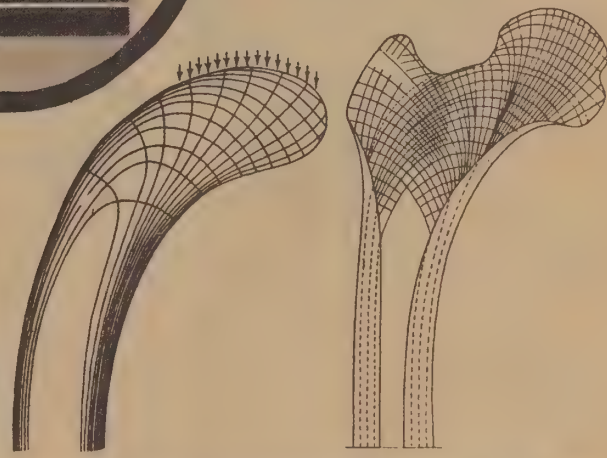

Fig. 101. Crane-head and femur. After Culmann and J. Wolff.



**The Sciences of the Artificial**

Simon says: we have generalized methods of obtaining elegant information from nature. We don't have generalized methods of making elegant things to add to nature; we lack a science of design. He's right and he doesn't waste much time being right, but proceeds to make useful suggestions—lots of them probably wrong and useful anyway. His notion of sub-system stability in evolution is beautiful.



**The Science of the Artificial**  
Herbert Simon  
1969; 123 pp.

**\$5.95** postpaid

from:  
The M.I.T. Press  
Room 765  
50 Ames Street  
Cambridge, Mass. 02142

or WHOLE  
EARTH  
CATALOG

**The Artifact as 'Interface'**

We can view the matter quite symmetrically. An artifact can be thought of as a meeting point—an 'interface' in today's terms—between an 'inner' environment, the substance and organization of the artifact itself, and an 'outer' environment, the surroundings in which it operates. If the inner environment is appropriate to the outer environment, or vice versa, the artifact will serve its intended purpose. Thus, if the clock is immune to buffeting, it will serve as a ship's chronometer. (And conversely, if it isn't, we may salvage it by mounting it on the mantel at home.)

...all mathematical derivation can be viewed simply as change in representation, making evident what was previously true but obscure. This view can be extended to all of problem solving—solving a problem simply means representing it so as to make the solution transparent. If the problem solving could actually be organized in these terms, the issue of representation would indeed become central.

I should like to point to evidence that there are only a few 'intrinsic' characteristics of the inner environment of thinking man that limit the adaptation of his thought to the shape of the problem environment. All else in his thinking and problem-solving behavior is artificial—is learned and is subject to improvement through the invention of improved designs.

Most of the complex structures found in the world are enormously redundant, and we can use this redundancy to simplify their description. But to use it, to achieve the simplification, we must find the right representation.

If a complex structure is completely unredundant—if no aspect of its structure can be inferred from any other—then it is its own simplest description.

**The Evolution of Complex Systems**

Let me introduce the topic of evolution with a parable. There once were two watchmakers, named Hora and Tempus, who manufactured very fine watches. Both of them were highly regarded, and the phones in their workshops rang frequently—new customers were constantly calling them. However, Hora prospered, while Tempus became poorer and poorer and finally lost his shop. What was the reason?

The watches the men made consisted of about 1,000 parts each. Tempus had so constructed his that if he had one partly assembled and had to put it down—to answer the phone, say—it immediately fell to pieces and had to be reassembled from the elements. The better the customers liked his watches, the more they phoned him and the more difficult it became for him to find enough uninterrupted time to finish a watch.

The watches that Hora made were no less complex than those of Tempus. But he had designed them so that he could put together subassemblies of about ten elements each. Ten of these subassemblies, again, could be put together into a larger subassembly; and a system of ten of the latter subassemblies constituted the whole watch. Hence, when Hora had to put down a partly assembled watch in order to answer the phone, he lost only a small part of his work, and he assembled his watches in only a fraction of the man-hours it took Tempus.

The time required for the evolution of a complex form from simple elements depends critically on the numbers and distribution of potential intermediate stable forms.

A little reflection reveals that cues signaling progress play the same role in the problem-solving process that stable intermediate forms play in the biological evolutionary process. In fact, we can take over the watchmaker parable and apply it also to problem solving. In problem solving, a partial result that represents recognizable progress toward the goal plays the role of a stable subassembly.

★  
The Human Condition

*At the end of a peyote meeting, in the morning, food and water are brought in by a woman designated to be Peyote Woman. Indian women are not supposed to speak up much on general subjects, and during a meeting the women are silent participants. But at dawn Peyote Woman has the floor and the power. She speaks of fundamental things like water and birth and nourishment with all the authority of the Earth and with awesome perception.*

*Hannah Arendt does the same in this book. Her subject is the elements of the human condition. Her perspective, the threshold of travel away from the Earth.*

The Human Condition  
Hannah Arendt  
1958; 385 pp.

\$1.45 postpaid

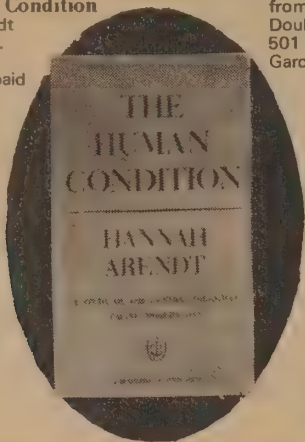

from:  
Doubleday & Co.  
501 Franklin  
Garden City, N. Y.  
11531

or WHOLE  
EARTH  
CATALOG

The task and potential greatness of mortals lie in their ability to produce things—works and deeds and words—which would deserve to be and, at least to a degree, are at home in everlastingness, so that through them mortals could find their place in a cosmos where everything is immortal except themselves.

It is true that one-man, monarchical rule, which the ancients stated to be the organizational device of the household, is transformed in society—as we know it today, when the peak of the social order is no longer formed by the royal household of an absolute ruler—into a kind of no-man rule. But this nobody, the assumed one interest of society as a whole in economics as well as the assumed one opinion of polite society in the salon, does not cease to rule for having lost its personality. As we know from the most social form of government, that is, from bureaucracy (the last stage of government in the nation-state just as one-man rule in benevolent despotism and absolutism was its first), the rule by nobody is not necessarily no-rule; it may indeed, under certain circumstances, even turn out to be one of its cruelest and tyrannical versions.

For us, appearance—something that is being seen and heard by others as well as by ourselves—constitutes reality. Compared with the reality which comes from being seen and heard, even the greatest forces of intimate life—the passions of the heart, the thoughts of the mind, the delights of the senses—lead an uncertain, shadowy kind of existence unless and until they are transformed, deprived and deindividualized, as it were, into a shape to fit them for public appearance.

Love, in distinction from friendship, is killed, or rather extinguished, the moment it is displayed in public. ("Never seek to tell thy love/ Love that never told can be.") Because of its inherent wordlessness, love can only become false and perverted when it is used for political purposes such as the change or salvation of the world.

Without actually standing where Archimedes wished to stand (*dos moi pou sto*), still bound to the earth through the human condition, we have found a way to act on the earth and within terrestrial nature as though we dispose of it from outside, from the Archimedean point. And even at the risk of endangering the natural life process we expose the earth to universal, cosmic forces alien to nature's household.

The Cartesian removal of the Archimedean point into the mind of man, while it enabled man to carry it, as it were, within himself wherever he went and thus freed him from given reality altogether—that is, from the human condition of being an inhabitant of the earth—has perhaps never been as convincing as the universal doubt from which it sprang and which it was supposed to dispel. Today, at any rate, we find in the perplexities confronting natural scientists in the midst of their greatest triumphs the same nightmares which have haunted the philosophers from the beginning of the modern age.

The Human Use of Human Beings

*A proper sequel to his Cybernetics [see p. 61], this book is social untechnical, ultimate in most of its considerations. Its domain is the whole earth of the mind.*

*Norbert Wiener is one of the founders of an n-dimensional inhabited world whose nature we've yet to learn.*

The Human Use of Human Beings

Norbert Wiener  
1950, 1954; 288 pp.

\$1.25 postpaid

from:  
Avon Books  
250 West 55th Street  
New York, N. Y. 10019

or WHOLE EARTH CATALOG

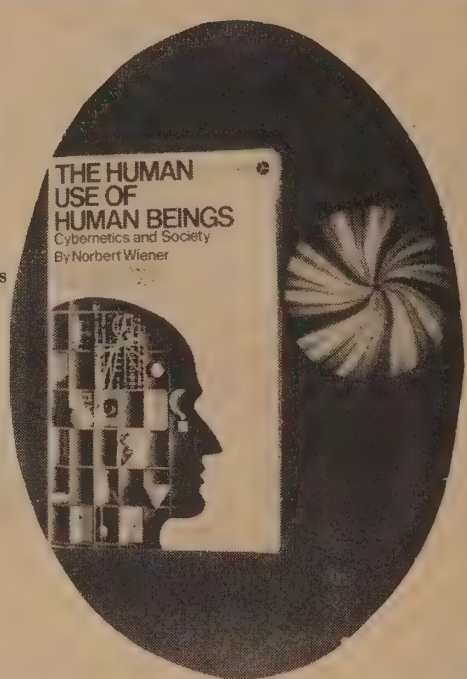

It is the thesis of this book that society can only be understood through a study of the messages and the communication facilities which belong to it; and that in the future development of these messages and communication facilities, messages between man and machine and between machine and machine, are destined to play an ever-increasing part.

Messages are themselves a form of pattern and organization. Indeed, it is possible to treat sets of messages as having an entropy like sets of states of the external world. Just as entropy is a measure of disorganization, the information carried by a set of messages is a measure of organization. In fact, it is possible to interpret the information carried by a message as essentially the negative of its entropy, and the negative logarithm of its probability. That is, the more probable the message, the less information it gives. Cliches, for example, are less illuminating than great poems.

I believe that Ashby's brilliant idea of the unpurposeful random mechanism which seeks for its own purpose through a process of learning is not only one of the great philosophical contributions of the present day, but will lead to highly useful technical developments in the task of automatization. Not only can we build purpose into machines, but in an overwhelming majority of cases a machine designed to avoid certain pitfalls of breakdown will look for purposes which it can fulfill.

We are not stuff that abides, but patterns that perpetuate themselves. A pattern is a message, and may be transmitted as a message.

It is the great public which is demanding the utmost of secrecy for modern science in all things which may touch its military uses. This demand for secrecy is scarcely more than the wish of a sick civilization not to learn the progress of its own disease.

It is illuminating to know that the sort of phenomenon which is recorded subjectively as emotion may not be merely a useless epiphenomenon of nervous action, but may control some essential stage in learning, and in other similar processes.

Human Use of the Earth

*To get a handle on your future you've got to get outside yourself, because only from outside can you see your space-time environment whole. One way is to identify out into another culture, Indian or whatever (this is Jim Nixon's idea). Another way is to take Philip Wagner's trip into fascinated objectivity about Earthly doings. In this book he merges some of the best of geographical and anthropological perspective into a detailed treatise on the Earth as tool, how it is used and how to understand it better to use it better.*

Symbiotic relations are those in which the life processes of one organism are in some essential way dependent upon other organisms. They may be either obligate relations, in which one individual cannot survive independently from other individuals, of the same or another kind; or facultative relations, in which an individual may, but need not, take advantage of the presence of some other organism to carry on its life processes. Using a broad conception of symbiosis, we shall speak of it as including 1) predation, in which an individual destroys members of its own or another species in seeking its own livelihood; 2) parasitism, in which an individual lives at the expense of other organisms without providing direct benefits to them; 3) mutualism, in which both individuals involved derive benefit from the relation; and 4) commensalism, in which two or more species or individuals of one species depend upon the same habitat conditions, which one or both may help to maintain.

The third and closest form of symbiosis among humans is full 'mutualism,' which we can equate with constitution of a single economy. There are three possible degrees of symbiosis among men: 1) those in which the mutual relationship which is the economy is much smaller in scope than the society (subsistence); 2) those in which there is a facultative mutual connection between the basic livelihood unit and the larger social group (peasant economies); and 3) those in which the limits of the economic unit and the social unit coincide, and the full obligate mutual relationship prevails throughout (commercial economy).

Eskimos keep their igloos hot. The microclimatology of buildings is a vast and little-known subject, but we may surmise that the interior climate of most kinds of buildings used by different human groups is about as follows: temperature mostly equal to or above prevailing outside temperature (except where thick walls are used, as in the Mediterranean area and Near East); humidity usually above the level of the open air; oxygen concentration considerably lower than outside, and carbon dioxide and other minor gases far more abundant; noxious odors very prevalent.

As we shall see, one of the strategies by which supplies of goods and services become available for actual use is the movement of the would-be consumers themselves to the sources of goods or services. There are even objects that act as containers of man himself, which move over land, across water or through the air, delivering the individual to the places at which he can obtain goods he desires, or where he will be served as he wishes.

The modern inhabitant of a commercial country does not make his world; he buys it. The material circumstances of his life are not the outcome of his individual encounter with the natural order, but arise out of his relations with the social order.

Ecologically speaking, even very primitive man is an extremely far-ranging creature. Men have migrated far more widely than almost any other animals.

Man has been described as a 'tool-using animal,' but as is well known, many other higher mammals can employ natural objects spontaneously as tools. Tool making, however, is peculiar to man.

Manufacture adds vastly to the wealth upon which men can draw by making more things usable. It confers the status of resources upon things that are of no benefit to any other animal.

Those same features of the most complex human communities which indicate their ecological advantages also suggest an unusual degree of inherent ecological risk. Such communities are complex and delicately balanced, and depend utterly upon their artificiality. They and the individuals in them are threatened by the same biological penalties that attend any highly specialized system or species. Their very technical perfection may destroy them in time as other high specializations have destroyed many former species of animals and plants.

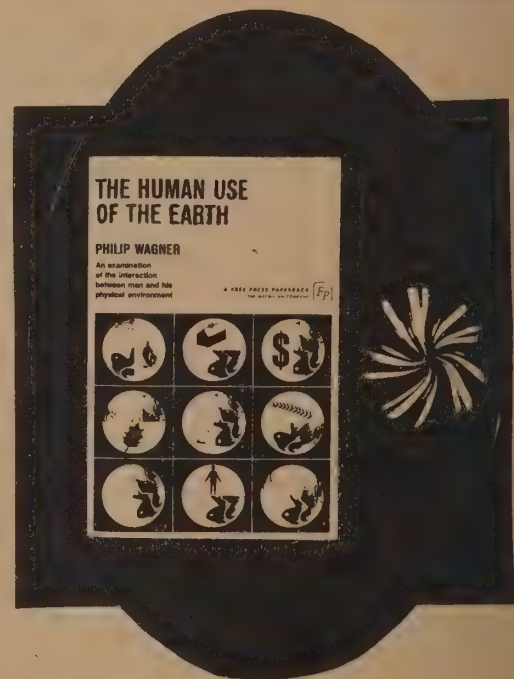

The Human Use of the Earth  
Philip Wagner  
1960; 270 pp.

\$1.95 postpaid

from:  
Free Press  
Macmillan Company  
Front and Brown Streets  
Riverside, New Jersey 08075

or WHOLE EARTH CATALOG

The individual organism must, on the one hand, be specialized enough in function to exploit some particular conditions in the habitat, so as to occupy a niche that no other organism can contest with it; and it must, on the other hand, possess enough versatility to adapt to any conditions of environment that may impinge upon its life activities. These two requirements may be thought of as polar extremes of a continuous scale, and every species may be placed somewhere along the scale between specialization and versatility. Some of the disadvantages of commitment to either specialization or versatility are overcome by aggregation of organisms into larger groups within the community.

★ **Man and His Symbols**

Carl Jung did a nice thing just before he died. He helped with a British effort to bring all of his work together in one richly illustrated introduction to the breadth of his realm. This book covers his concepts of the unconscious, myths, individuation, the visual arts, dreams, and analysis. Why aren't all psychology books illustrated?

**Man and His Symbols**  
Carl G. Jung  
1964; 320 pp.

**\$5.95** postpaid

from:  
Doubleday & Co.  
501 Franklin  
Garden City, N. Y. 11531

or **WHOLE EARTH CATALOG**



The sign is always less than the concept it represents, while a symbol always stands for something more than its obvious and immediate meaning.

Abstract mandalas also appear in European Christian art. Some of the most splendid examples are the rose windows of the cathedrals. These are representations of the Self of man transposed onto the cosmic plane. (A cosmic mandala in the shape of a shining white rose was revealed to Dante in a vision.) We may regard as mandalas the haloes of Christ and the Christian saints in religious paintings.



Oh, come, lonely hunter in the stillness of dusk.  
Come, come! I miss you, I miss you!  
Now I will embrace you, embrace you!

Come, come! My nest is near, my nest is near.  
Come, come, lonely hunter, now in the stillness of dusk.

He throws off his clothes and swims across the river, but suddenly she flies away in the form of an owl, laughing mockingly at him. When he tries to swim back to find his clothes, he drowns in the cold river.

★ **The Unexpected Universe**

Loren Eiseley celebrates our grandest ignorances, the places in human experience where if you stare into them, the void stares back. City dumps; the open end of evolution; the unexplored continent in your mind; stars; a Pharaoh's dead gesture; edges of oceans. Strong useful prose from an old guy who knows something clear and bleak about regeneration.

**The Unexpected Universe**  
Loren Eiseley  
1969; 239 pp.

**\$5.75** postpaid

from:  
Harcourt, Brace & World, Inc.  
757 Third Avenue  
New York, N. Y. 10017

or **WHOLE EARTH CATALOG**

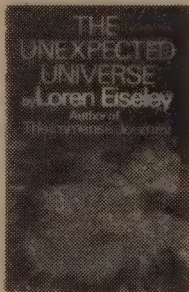

A car is another kind of possession that is usually feminized—i.e., that can become the focus of many men's anima projections. Like ships, cars are called "she," and their owners caress and pamper them like favorite mistresses.

When an individual makes an attempt to see his shadow, he becomes aware of (and often ashamed of) those qualities and impulses he denies in himself but can plainly see in other people . . .

If you feel an overwhelming rage coming up in you when a friend reproaches you about a fault, you can be fairly sure that at this point you will find a part of your shadow, of which you are unconscious.



Around me in the gloom, dark shapes worked ceaselessly at the dampened fires. My eyes were growing accustomed to their light.

"We get it all," the dump philosopher repeated. "Just give it time to travel, we get it all."

Men, unknowingly, and whether for good or ill, appear to be making their last decisions about human destiny. To pursue the biological analogy, it is as though, instead of many adaptive organisms, a single gigantic animal embodied the only organic future of the world.

Every time we walk along a beach some ancient urge disturbs us so that we find ourselves shedding shoes and garments, or scavenging among seaweed and whitened timbers like the homesick refugees of a long war.

It was the failures who had always won, but by the time they won they had come to be called successes. This is the final paradox, which men call evolution.

★ **The King and the Corpse**

I know of no better myth-telling than this, and no better myths. You've got Abu Kasem's Slippers, and then Conn-eda and John Golden-Mouth, and four romances from King Arthur that take deeper turns than T. H. White, the King and the Corpse, and the prize: the ancient Hindu Romance of the Goddess, plumbing the involuntary creation. Collected by Heinrich Zimmer, edited by Joseph Campbell. There's few books with such a blend of extravagance and intelligence.

[Suggested by Jim Fadiman]

**The King and the Corpse**  
Heinrich Zimmer; Joseph Campbell, ed.  
1948; 338 pp.

**\$1.75** postpaid

from:  
Meridian Books, Inc.  
World Publishing Co.  
2231 West 110th Street  
Cleveland, Ohio 44102

or **WHOLE EARTH CATALOG**



The involvement of the gods in the web of their own creation, so that they become, like Abu Kasem, the harried victims of their creatures, entangled in nets of not quite voluntary self-manifestation, and then mocked by the knowing laughter of their own externally reflected inner judge: this is the miracle of the universe. This is the tragicomic romance of the world. The gods, the fairy powers, are always in danger of self-enchantment. Like the youth Narcissus, they become fixed to their own reflected images—momentarily reluctant to pass with the passing of time, and critically in need of the shocking, shattering blow of the redemptive catastrophe. Man is the little world creator; God, the great. Each, surrounded by the figments of his own mirrored depths, knows and suffers the cosmic self-torment. And the fatal power that enchants them both is ever the great goddess, Māyā, self-delusion, the supreme creatrix of all the worlds.

Brahmā, sinking still further into the limp darkness of his own interior, struck a new depth: suddenly the most beautiful dark woman sprang from his vision, and stood naked before everyone's gaze.

She was Dawn, and she was radiant with vivid youth. Nothing like her had yet appeared among the gods; nor would her equal ever be seen, either among men, or in the depths of the waters in the jeweled palaces of the serpent queens and kings. The billows of her blue-black hair were glistening like the feathers of a peacock, and her clearly curving, dark brows formed a bowfit for jeweled palaces of the serpent queens and kings. The billows of her blue-black hair were glistening like the feathers of a peacock, and her clearly curving, dark brows formed a bow fit for the God of Love. Her eyes, like dark lotus calyxes, had the alert, questioning glance of the frightened gazelle; and her face, round as the moon, was like a purple lotus blossom. Her swelling breasts with their two dark points were enough to infatuate a saint. Trim as the shaft of a lance stood her body, and her smooth legs were like the stretched-out trunks of elephants. She was glowing with little delicate pearls of perspiration. And when she found herself in the midst of her startled audience, she stared about at them, in uncertainty, then broke into a softly rippling laugh.

The course of the world runs awry, but therewith it goes directly to its goal. The catastrophe of the previously unforeseen is what breaks the world progression forward, and the moment the catastrophe has come to pass it appears to be what was intended all the while. For it is creative in a deeper way than the planning creative spirit supposes. It transforms the situation, forces an alteration on the creative spirit, and throws it into a play that carries it beyond itself, carries it, that is to say, really and properly into play, and into a play that entrains the entirety of creation. The planner, the watcher, is compelled to become the endurer, the sufferer. Such a metamorphosis into the opposite, into the absolutely alien, is what throws the knots that reticulate the net of the living whole and mesh the individual alive into the fabric.

Shiva's visage became radiant with joy. In the presence of all the Holy Ones he lapsed, absorbed, into introverted vision. Then he permitted himself to sink to the floor, legs crossed, shut his eyes, and sank into his being to the depth of the Being Sublime. His body began to glow, so that the eyes of all the Holy Ones present became dazzled. And the moment he reached quietude in this immersion, Vishnu's Māyā fell away from around him, and his entire body burst into such a radiance that even his own hosts were unable to bear the blast. Vishnu passed into him, poured into him as the pure Light of Heaven, and disclosed within Shiva's body, to the eye of his inner contemplation, the whole lotus-spectacle of creation and the procession of the world. Blissful and serene, beyond the senses and their universes of distinctions, alone and pure, beholding everything, the abstracted one experienced within his own being the Being Supreme, that Substratum of all Unfoldments. He beheld, riveted in contemplation, how the One Substance exfoliates into all the delectations of the world.

Shiva, bereaved, distracted, was conducted gently by his guru, Brahmā, out of the gates of the city of his life's loss and away into the Himalayan peaks of snow. There, walking together, the two came upon a little lake of solitude, clear, and delightful to the mind. Brahmā perceived it first.

And seated here and there about the quiet shores were saints and sages in absolute meditation; two or three stood bathing in the cool crystal waters, sending ripples out across its mirroring of the blue and immobile, high, mountain sky. Many migratory birds, shrilly crying, were coming from all directions to flutter down into its lotus-bordered waters—pairs of splendid ruddy geese beautifully spreading out their great wings in exultation, cormorants with their hooked bills, gray-winged geese, and Siberian cranes, stalking about the shores, floating on the surface of the lake, peering into the waters, themselves beautifully reflected—and, occasionally, with a sudden thunderous beating of hundreds of wings, all lifting out of the lake into the sky, to circle in many companies, and presently return to settle, flutter, and preen. And beneath them, in the crystalline depths, were swimming fish of innumerable brilliant hues, visible as they darted in and out among the lotus stems. Lotus buds, lotus chalices, blue lotuses and white were abundant there; and the vegetation about the shores was luxurious and of cool shade.

**Technics and Civilization**

*I first read this book in 1957 then again in 1963 and then part of it in 1969.*

*Here is the first paragraph of the book.*

During the last thousand years the material basis and the cultural forms of Western Civilization have been profoundly modified by the development of the machine. How did this come about? Where did it take place? What were the chief motives that encouraged this radical transformation of the environment and the routine of life: what were the ends in view: what were the means and methods: what unexpected values have arisen in the process? These are some of the questions that the present study seeks to answer.

*Lewis Mumford is an unusual man. He is not an engineer or a scientist, he isn't an historian or sociologist, you can't identify him as a business man or a literary man or an academic. He seems beyond all those roles. This made him especially attractive to me when I was 19 because his style smelled of the place I wanted to go. He is profound, poetic knowledgeable. He takes care of the large and small things in his books.*

*Technics and Civilization is a good book to start with; if you like it, there are many others of his to turn to. Myth of the Machine, Arts and Technics, The City in History, Transformations of Man.*

*How I have used him: all through my twenties I used him as my guide.*

*[Suggested and reviewed by Steve Baer]*



2: The printing press was a powerful agent for producing uniformity in language and so, by degrees, in thought. Standardization, mass-production, and capitalistic enterprise came in with the printing press; and not without irony, the oldest known representation of the press, shown here, appeared in a Dance of Death printed at Lyons in 1499.

**The Age of Discontinuity**

*How come Peter Drucker has so much good sense and perspective, and still remains so cheerful? Traditionally considerations such as his—economics, organizations, the future—turn a prophet's soul terrible and dark or at least partially wiggly. The only other intact floater on this ocean I know of is Marshall McLuhan. You sense that both of them have a backyard in their mind that resides somewhere else, some time else. (It would be worth pursuing this. How To Think Big and Stay Sane.)*

*The Age of Discontinuity takes notice of the remarkable continuity of the last 50 years in building on the technological breakthroughs of the Victorian era. Now, says Drucker, we are in for some hard changes, particularly around new technologies (of information, materials, oceans, megalopolis), global economics, and redistribution of responsibility in large organizations.*

**The Step to Man**

*I'll be damned. I thought this was another yessir-things-are-changing technological social treatise thing. No such. It's a manual of strategies for changing the world, if you have a mind to do that. Not heavy stuff about what is terrible or what should happen, but how to remake life and stay alive in the process. Strategies like multiple working hypotheses so you don't get infatuated with your first idea. Like seed operations where one phone call makes the whole thing happen. Like self-stabilizing provisions so a process is safe from its own too-quick successes.*

*[Suggested by Steve Baer]*

On any given morning at the Laboratory of Molecular Biology in Cambridge, England, the blackboards of Francis Crick or Sidney Brenner will commonly be found covered with logical trees. On the top line will be the hot new result just up from the laboratory or just in by letter or rumor. On the next line will be two or three alternative explanations, or a little list of "What he did wrong." Underneath will be a series of suggested experiments or controls that can reduce the number of possibilities. And so on. Three trees grows during the day as one man or another comes in and argues about why one of the experiments wouldn't work, or how it should be changed.

As the philosopher Karl Popper says today, there is no such thing as proof in science—because some later alternative explanation may be as good or better—so that science advances only by disproofs. There is no point in making hypotheses that are not falsifiable, because such hypotheses do not say anything: "it must be possible for an empirical scientific system to be refuted by experience."

The difficulty is that disproof is a hard doctrine. If you have a hypothesis and I have another hypothesis, one of them must evidently be eliminated. The scientist seems to have no choice but to be either soft-headed or disputatious. Perhaps this is why so many tend to resist the strong analytical approach—and why some great scientists are so disputatious.

Choice manifests itself in society in small increments and moment-to-moment decisions as well as in loud dramatic struggles; and he who does not see choice in the development of the machine merely betrays his incapacity to observe cumulative effects until they are bunched together so closely that they seem completely external and impersonal. No matter how completely technics relies upon the objective procedures of the sciences, it does not form an independent system, like the universe: it exists as an element in human culture and it promises well or ill as the social groups that exploit it promise well or ill. The machine itself makes no demands and holds out no promises: it is the human spirit that makes demands and keeps promises. In order to reconquer the machine and subdue it to human purposes, one must first understand it and assimilate it. So far, we have embraced the machine without fully understanding it, or like the weaker romantics, we have rejected the machine without first seeing how much of it we could intelligently assimilate.

**Technics and Civilization**  
Lewis Mumford  
1934, 1962; 495 pp.

**\$3.75** postpaid

from:  
Harcourt, Brace & World  
757 Third Avenue  
New York, N. Y. 10017

or WHOLE EARTH CATALOG

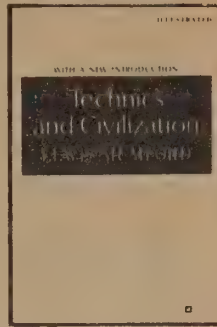

Most of the important inventions and discoveries that served as the nucleus for further mechanical development, did not arise, as Spengler would have it, out of some mystical inner drive of the Faustian soul: they were wind-blown seeds from other cultures. After the tenth century in Western Europe the ground was, as I have shown, well plowed and harrowed and dragged, ready to receive these seeds; and while the plants themselves were growing, the cultivators of art and science were busy keeping the soil friable. Taking root in medieval culture, in a different climate and soil, these seeds of the machine sported and took on new forms: perhaps, precisely because they had not originated in Western Europe and had no natural enemies there, they grew as rapidly and gigantically as the Canada thistle when it made its way onto the South American pampas. But at no point—and this is the important thing to remember—did the machine represent a complete break. So far from being unprepared for in human history, the modern machine age cannot be understood except in terms of a very long and diverse preparation. The notion that a handful of British inventors suddenly made the wheels hum in the eighteenth century is too crude even to dish up as a fairy tale to children.

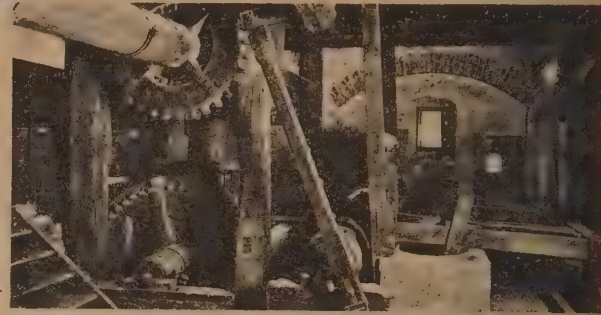

Old Paper Mill. Note that the wheels and shafts are almost entirely composed of wood. This material lingered on in machine-building and in mill-construction well into the nineteenth century. Metal was, up to the paleotechnic period, merely an accessory, used where a cutting edge or a resistant material was imperative, as in the runner of a skate. (Courtesy, Deutsches Museum, München)

If the mechanical clock did not appear until the cities of the thirteenth century demanded an orderly routine, the habit of order itself and the earnest regulation of time-sequences had become almost second nature in the monastery. Coulton agrees with Sombart in looking upon the Benedictines, the great working order, as perhaps the original founders of modern capitalism: their rule certainly took the curse off work and their vigorous engineering enterprises may even have robbed warfare of some of its glamor. So one is not straining the facts when one suggests that the monasteries—at one time there were 40,000 under the Benedictine rule—helped to give human enterprise the regular collective beat and rhythm of the machine; for the clock is not merely a means of keeping track of the hours, but of synchronizing the actions of men. . . . The instrument presently spread outside the monastery; and the regular striking of the bells brought a new regularity into the life of the workman and the merchant. The bells of the clock tower almost defined urban existence. Time-keeping passed into time-serving and time-accounting and time-rationing. As this took place, Eternity ceased gradually to serve as the measure and focus of human actions.

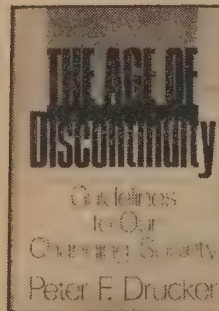

**The Age of Discontinuity**  
Peter F. Drucker  
1969; 401 pp.

**\$7.95** postpaid

from:  
Harper & Row  
49 East 33rd Street  
New York, N. Y. 10016

or WHOLE EARTH CATALOG



Measured by the yardsticks of the economist, the last half-century has been an Age of Continuity—the period of least change in three hundred years or so, that is, since world commerce and systematic agriculture first became dominant economic factors in the closing decades of the seventeenth century. . . .

What is amazing is perhaps not that it took a half-century for the work and thought of those earlier generations to bring full fruit. It is that the generation of 1900, which we tend today to look down on as stodgy stick-in-the-muds, laid down economic foundations of such strength and excellence that they have prevailed over all the wickedness, criminal insanity, and suicidal violence of the last fifty years. The towering economic achievements of today, the affluent, mass-consumption economies of the advanced countries, their productivity and their technological powers, are built four-square on Victorian and Edwardian foundations and out of building blocks quarried then. They are, above all, a fulfillment of the economic and technological promises of the Victorian and Edwardian eras and a testimony to their economic vision.

Now, however, we face an Age of Discontinuity in world economy and technology. We might succeed in making it an age of great economic growth as well. But the one thing that is certain so far is that it will be a period of change—in technology and in economic policy, in industry structures and in economic theory, in the knowledge needed to govern and to manage, and in economic issues.

While we have been busy finishing the great nineteenth-century economic edifice, the foundations have shifted under our feet.

Since the computer first appeared in the late 1940's the information industry has been a certainty. But we do not have it yet. We still do not have the effective means to build an "information system." This is where the work is going on, however. The tools to create information systems may already exist: the communications satellite and other means of transmitting information, microfilm and the TV tube to display and store it, rapid printers to reduce it to permanent record, and so on. There is no technical reason why someone like Sears Roebuck should not come out tomorrow with an appliance selling for less than a TV set, capable of being plugged in wherever there is electricity, and giving immediate access to all the information needed for schoolwork from first grade through college.

Yet though IBM is now shipping computers at a rate of a thousand a month, we do not have the equivalent of Edison's light bulb. What we are lacking is not a piece of hardware like the light bulb. What we still have to create is the conceptual understanding of information. As long as we have to translate laboriously every set of data into a separate "program," we do not understand information. We have to be capable of classifying information according to its characteristics. We have to have a "notation," comparable to the one St. Ambrose invented 1,600 years ago to record music, that can express words and thoughts in symbols appropriate to electronic pulses rather than in the clumsy computer language of today. Then each person could, with very little training, store his own data within a general system, that is, in what the computer engineers call a "routine." Then we shall have true "information systems."

We begin to realize that our brains are the most complex and self-determining things in the known universe. After all the measurements of atoms and galaxies are folded into laws in some corner of our networks, there will still be universes of interrelationships in the rest of our networks to be discovered. If this property of complexity could somehow be transformed into visible brightness so that it would stand forth more clearly to our senses, the biological world would become a walking field of light compared to the physical world. The sun with its great eruptions would fade to a pale simplicity compared to a rosebush. An earthworm would be a beacon, a dog would be a city of light, and human beings would stand out like blazing suns of complexity, flashing bursts of meaning to each other through the dull night of the physical world between. We would hurt each other's eyes. Look at the haloed heads of your rare and complex companions. Is it not so?

We face major changes in the world's economy. In economic policies and theories, we still act as if we lived in an "international" economy, in which separate nations are the units, dealing with one another primarily through international trade and fundamentally as different from one another in their economy as they are different in language or laws or cultural tradition. But imperceptibly there has emerged a world economy in which common information generates the same economic appetites, aspirations, and demands—cutting across national boundaries and languages and largely disregarding political ideologies as well. The world has become, in other words, one market, one global shopping center. Yet this world economy almost entirely lacks economic institutions; the only—though important—exception is the multinational corporation. And we are totally without economic policy and economic theory for a world economy.

**The Step to Man**  
John R. Platt  
1966; 216 pp.

**\$6.95** postpaid

from:  
John Wiley and Sons Publishing Co.  
1 Wiley Drive  
Somerset, N. J. 08873

Western Distribution:  
1530 South Redwood Road  
Salt Lake City, Utah 84104

or WHOLE EARTH CATALOG



Beware of the man of one method or one instrument, either experimental or theoretical. He tends to become method-oriented rather than problem-oriented. The method-oriented man is shackled; the problem-oriented man is at least reaching freely toward what is most important. Strong inference redirects a man to problem-orientation, but it requires him to be willing repeatedly to put aside his last methods and teach himself new ones.

In order to carry out any great project, the future good of the group must be anticipated and turned into present and individual good, into a reward for every step that is taken in the right direction.

I am beginning to believe that in any social endeavor, it is the analysis of chain-reacting social processes that will enable us to choose the best course and will indicate the most effective ways for our intelligence to multiply its feeble energies. The future is waiting to respond to a touch, if it is the right touch. It is ingenuity we need, not lamentations. The world's future becomes almost plastic in the light of these possibilities.

**Process and Pattern in Evolution**

Since asserting that 'Evolution and cybernetics are going to come together; this is the edge of knowledge right now, and it's right at the heart of education, and the schools don't know it,' I've been looking for a book that would tidily summarize what is known about biological evolution. Here 'tis.

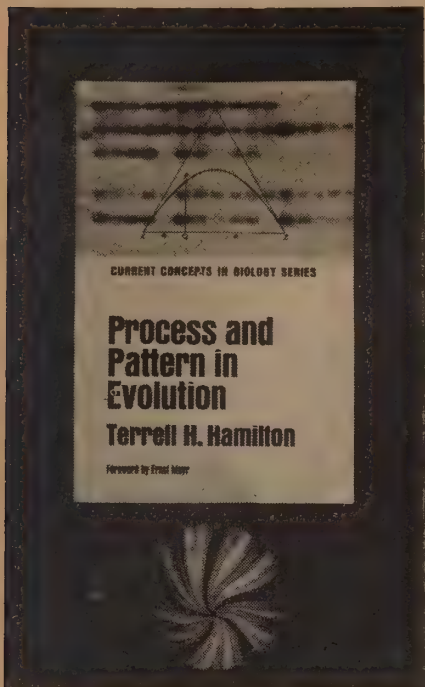

The reproducing individual is the unit of selection, the gene or gene substitution is the unit or unit process of population adaptation, and the species is the unit of evolution.

It is not the gene that is the unit of selection, but rather the whole individual. It is the 'goodness' of the whole organism that natural selection evaluates and either rewards or discriminates against.

- Individuals are not identical, but vary in their characteristics.
- Those variants that naturally fit their environments will be favored over those less fit. By inheritance those individuals better fit will pass their characteristics on to the next and future generations in greater numbers than those less fit.
- The following generations of individuals will exhibit, and continue to improve, the adaptations realized in gradual changes by their ancestors.

**Process and Pattern in Evolution**  
Terrell H. Hamilton  
1967; 118 pp.

\$1.95 postpaid

from:  
The Macmillan Co.  
Front and Brown Streets  
Riverside, N. J. 08075

or WHOLE EARTH CATALOG

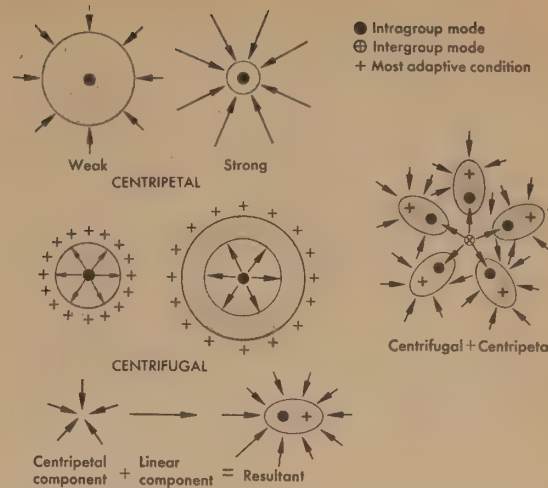

Figure 4-1. Direction of selection in relation to intensity, showing the theoretical possibilities of a centrifugal, centripetal, linear, or resultant selection. The shaded areas represent ranges of variations covered by the populations. [After G. G. Simpson, *The Major Features of Evolution*, New York: Columbia University Press, 1953.]

Ernst Mayr and others have reminded us that as a crude generalization it may be said that non-genetic variation adapts the individual, while genetic variation adapts the population.

Mutation is an incoherent if not random process which provides de novo changes in genes and chromosomes. Recombination, by far more frequent in occurrence, provides new individual variations within populations to a much greater degree than mutation. Indeed most of the individual genetic variations observed within populations are of a recombinational origin. But these are new variations limited to a range set by a preexisting genetic theme. New genetic themes arise only by mutation.

**Man Adapting**  
René Dubos  
1965; 527 pp.

\$3.75 postpaid

from:  
Yale University Press  
149 York Street  
New Haven, Conn. 06511

or WHOLE EARTH CATALOG

**Man Adapting**

The focus of this book is the human individual, what he has to deal with in this life, and what means he has to do the dealing with. Dubos is a superdoctor, so you get a damned well-informed medical perspective on questions of environment, population, health, nutrition, adaptation, etc. that subverts many a popular opinion.

The concept of perfect and positive health is a utopian creation of the human mind. It cannot become reality because man will never be so perfectly adapted to his environment that his life will not involve struggles, failures, and sufferings. Nevertheless, the utopia of positive health constitutes a creative force because, like other ideals, it sets goals and helps medical science to chart its course toward them. The hope that disease can be completely eradicated becomes a dangerous mirage only when its unattainable character is forgotten. It can then be compared to a will-o'-the-wisp luring its followers into the swamps of unreality. In particular, it encourages the illusion that man can control his responses to stimuli and can make adjustments to new ways of life without having to pay for these adaptive changes. The less pleasant reality is that in an ever-changing world each period and each type of civilization will continue to have its burden of diseases created by the unavoidable failures of adaptation to the new environment.

The paradoxical truth is that the phenomenal increase in world population during the past 50 years has coincided with great epidemics, two world wars, several minor ones, and deep disruptions of social and economic life everywhere. Furthermore, as is well known, the most destitute and disease-ridden populations of the world are precisely the ones that are increasing the fastest.

As is well known, India is one of the countries where the overpopulation problem is most acute, and also where government agencies have been most active, imaginative, and bold in developing birth control. Yet several pages of the special issue devoted to 'The Wisdom of India' consist of endearing photographs illustrating the theme that children are the country's greatest wealth; their charm and the love bestowed on them constitute the most important source of happiness; their presence makes life bearable and enjoyable even in the most impoverished villages.

It is not for the sake of originality that I shall use here the word 'avalanche' instead of the more orthodox 'explosion' to refer to the present increase in the world population. My reason is that the word avalanche conveys more accurately the important truth that this increase is not a sudden event, as the word explosion would suggest, but rather corresponds to a continuous process that has to reach a certain momentum before it becomes dangerous. Public alarm is justifiable because the increase is now occurring simultaneously all over the world, and because its rate seems to be accelerating.

Lead poisoning is commonly found among children in the poorer and older areas of all American cities; it results from their ingestion of paint applied on the interior woodwork of houses and on furniture.

The truth is, that improvements in the general nutritional state began when prosperity and greater facilities for the transportation of food made it possible for many people to afford at least one square meal a day; likewise, the mortality of many infections began to recede in a dramatic fashion in Western Europe and North America long before the introduction of specific methods of therapy, indeed before the demonstration of the germ theory of disease.



**The Phenomenon of Man**

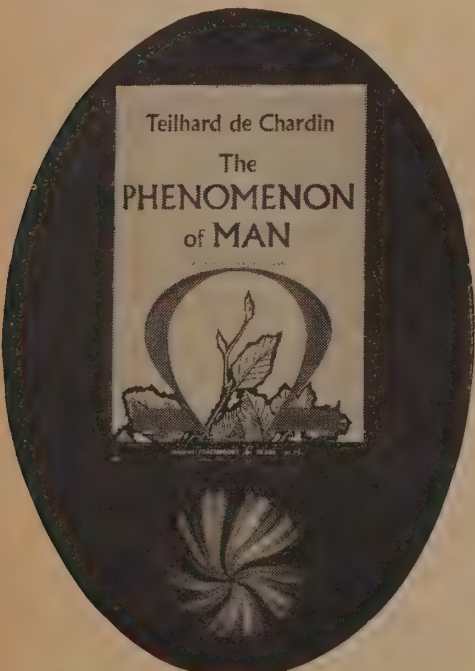

Reading *The Phenomenon of Man* is a bit unnerving: Teilhard de Chardin manages to say most of the things many of us are trying to say. He said them in 1938. Was no-one listening?

*The Phenomenon of Man* deals with evolution—the ascent to consciousness. The plan of the book is

Pre-life: Life: Thought—three events sketching in the past and determining for the future (survival) a single and continuing trajectory, the curve of the phenomenon of man.

His aim is to try to see (and to help us to see)

to try to develop a homogeneous and coherent perspective of our general extended experience of man. A whole which unfolds.

Teilhard de Chardin's vision and expression of that vision are beautiful—of man evolving a super-abundance of mind; in the noosphere where the All and the Person are one. The only way to put all this together without feeling bullshitted is to read *The Phenomenon of Man*.

Only one reality seems to survive and be capable of succeeding and spanning the infinitesimal and the immense: energy—that floating, universal entity from which all emerges and into which all falls back as into an ocean; energy, the new spirit, the new God.

homination...noogenesis...cosmogensis...when Teilhard de Chardin uses a simple word like homogeneous something magical happens to it.

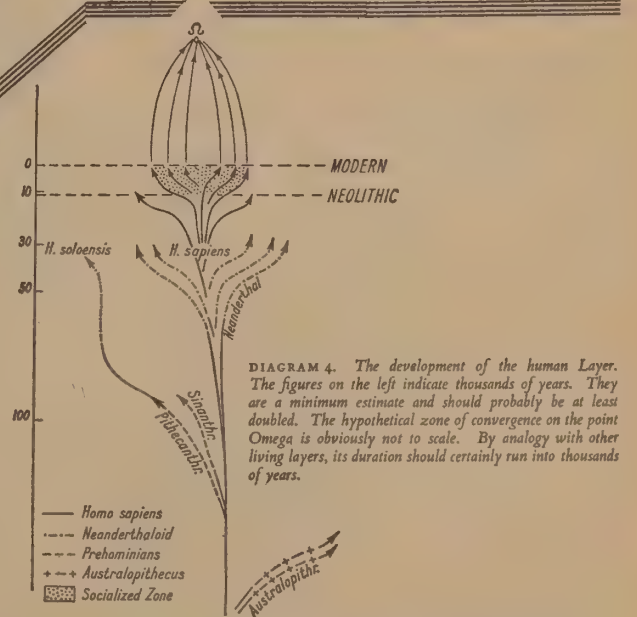

DIAGRAM 4. The development of the human Layer. The figures on the left indicate thousands of years. They are a minimum estimate and should probably be at least doubled. The hypothetical zone of convergence on the point Omega is obviously not to scale. By analogy with other living layers, its duration should certainly run into thousands of years.

The Omega point is where man is God and God is man, where all layers of the noosphere become involuted, fusing and consuming the All and the Person integrally in itself.

The mind is essentially the power of synthesis and organisation.

Underlying the beautiful presentation of man's ascent towards consciousness is a hard core of science:

Man, in nature, is a genuine fact, falling...within the scope of the requirements and methods of science.

**The Phenomenon of Man**

from:  
Harper & Row  
49 East 33 Street  
New York, N. Y. 10016

Teilhard de Chardin  
1959; 320 pp.

\$1.95 postpaid

or WHOLE EARTH CATALOG

[Reviewed by Dave Evans.  
Suggested by Julia Brand.]

**The Year 2000**

*Is Herman Kahn the bad guy (as liberal opinion would have it) or a good guy (as in some informed opinion)? Kahn will hang you on that question and while you're hanging jam information and scalding notions into your ambivalence. He does this best with a live audience, but this book is a fine collection of the information he uses.*

*Here is most of the now-basic methodology of future study—multi-fold trends, surprise-free projections, scenarios, etc. And here are their results. It's the best future-book of the several that are out.*

*In my opinion, it is not particularly an accurate picture of the future but the most thorough picture we have of the present—the present statistics, present fantasies, present expectations that we're planning with. We are what we think our future is.*

If computer capacities were to continue to increase by a factor of ten every two or three years until the end of the century (a factor between a hundred billion and ten quadrillion), then all current concepts about computer limitations will have to be reconsidered. Even if the trend continues for only the next decade or two, the improvements over current computers would be factors of thousands or millions. If we add the likely enormous improvements in input-output devices, programming and problem formulation, and better understanding of the basic phenomena being studied, manipulated, or simulated, these estimates of improvement may be wildly conservative. And even if the rate of change slows down by several factors, there would still be room in the next thirty-three years for an overall improvement of some five to ten orders of magnitude. Therefore, it is necessary to be skeptical of any sweeping but often meaningless or nonrigorous statements such as "a computer is limited by the designer—it cannot create anything he does not put in," or that "a computer cannot be truly creative or original." By the year 2000, computers are likely to match, simulate, or surpass some of man's most "human-like" intellectual abilities, including perhaps some of his aesthetic and creative capacities, in addition to having some new kinds of capabilities that human beings do not have. These computer capacities are not certain; however, it is an open question what inherent limitations computers have. If it turns out that they cannot duplicate or exceed certain characteristically human capabilities, that will be one of the most important discoveries of the twentieth century.

**The Year 2000**  
Herman Kahn and Anthony J. Wiener  
1967; 431 pp.

**\$9.95** postpaid

from:  
The Macmillan Company  
Front and Brown Streets  
Riverside, Burlington County  
New Jersey 08075

or **WHOLE EARTH CATALOG**



**TABLE IX**

*The Postindustrial (or Post-Mass Consumption) Society*

1. Per capita income about fifty times the preindustrial
2. Most "economic" activities are tertiary and quaternary (service-oriented), rather than primary or secondary (production-oriented)
3. Business firms no longer the major source of innovation
4. There may be more "conservatives" (vs. "marketives")
5. Effective floor on income and welfare
6. Efficiency no longer primary
7. Market plays diminished role compared to public sector and "social accounts"
8. Widespread "cybernation"
9. "Small world"
10. Typical "doubling time" between three and thirty years
11. Learning society
12. Rapid improvement in educational institutions and techniques
13. Erosion (in middle class) of work-oriented, achievement-oriented, advancement-oriented values
14. Erosion of "national interest" values
15. Sensate, secular, humanist, perhaps self-indulgent criteria become central

**The Futurist**

*In part because the Future is a new field of methodic study this is a lively newsletter. It reports bi-monthly on new books and programs having anything to do with social forecasting. Future study is like education: everybody thinks they're good at it. The newsletter has some of that diluted flavor, but it doesn't matter. Useful pointing at useful activities done here.*

**The Futurist**  
**\$5.00** for one year.

from:  
World Future Society  
P.O. Box 19285  
20th Street Station  
Washington, D.C. 20036

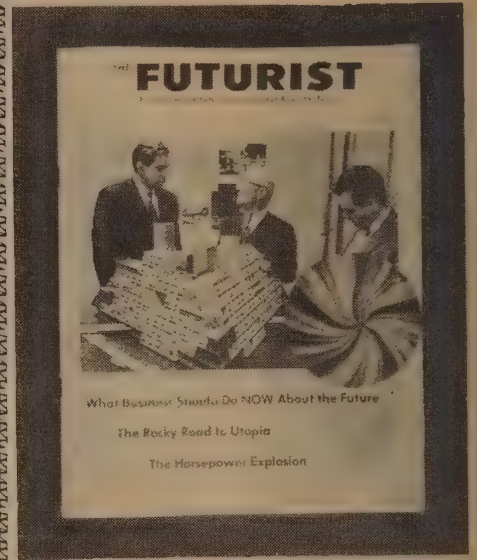

One of the things which gives life in Ciudad Guayana its particular dynamism is the fact that its participants know themselves to be part of history. If people in the city, if the residents of La Laja often speak, as they do, of "the future," in a general sense aside from their own personal prospects, it is because the world has changed so rapidly in their own lifetimes that they are unable to perceive the past as more than a series of events, as representing historical process, continuing into a future.

The roads, radios, and schools financed by oil meant not only a sharp rise in literacy—illiteracy dropped from 71 per cent in 1936 to an estimated 26 to 28 percent in 1960—but also a general spread of sophistication of several kinds. There was sophistication in self-presentation; I have seen girls in isolated rural settlements to the south of Ciudad Guayana wearing tight slacks and upswept hairdos in completely urban style.

The bar is the most impressive business in La Laja. None of La Laja's businesses is of a volume to be "really" profitable; they continue in terms of a situation in which the opportunity cost to the entrepreneur is, in effect, zero. Meanwhile, observations would suggest that they are perpetuated not only by the tiny incomes they supply but as much or more by a sort of return not easily entered on a bookkeeper's balance sheet: the pleasure of social interaction and the self-esteem which comes from having a visible capital and from exercising the skills of entrepreneurship.

The community does not have to act as a whole to initiate procedures for solving some general problems; all it takes is a sufficiently active and influential working segment. Two men build a playground; ten sign a petition; three go to put pressure on the municipal council; thirty lay a water line. An undue stress on developing organization "representing the whole community" may actually make it harder to get things done by forcing individuals to choose sides, rather than choosing between action and inaction in a given enterprise.

The general development planning and urban design functions of the CVG were being carried out far away from the people of La Laja, on the thirteenth floor of the Shell Building, 350 miles away in Caracas. Some individuals in San Félix—the priests, certain political and economic leaders—from time to time made visits to these offices, but to my knowledge no resident of La Laja had ever been there, and certainly the overwhelming majority had no conception of that far-off world in which La Laja appeared on maps as an area encircled by the planners' "Magic Marker" or zipatone symbols.

In looking at the history of the sewer controversy, it is clear that there were at least three major barriers to the communication of concerns from the people at the bottom to the "competent authorities" at the top of the system. These barriers to communication I suppose to be characteristic not only of the Corporación de Guayana, but also of other agencies in Venezuela, and not only of agencies in Venezuela, but of bureaucratic systems in similar societies around the world. These barriers to communication impinge on "the people" as lack of knowledge of the power structure, inaccessibility of the power structure in terms of time, distance, and financial cost, and social class barriers. I was very useful to the people of La Laja in dealing with all three classes of barriers.

There is no one who is making his political capital out of the satisfactions and dissatisfactions at the barrio level except very local politicians, and the structure of institutions which would amalgamate these little local stocks of political capital into some sort of national party fund of support is still undeveloped.

In this institutional context, the propensity to violence in Venezuela becomes understandable. It is like the steam which cracks the closed boiler; it is a way of expressing dissatisfaction in a society which lacks the channels, the institutions, for protesting legally in any effective way. So first one puts up a sign by the highway or uses the radio to direct the attention of the "competent authorities" to the problem and then, if still feeling strongly, one looks for dynamite.

**The View from the Barrio**

*What a refreshment this book was after reading a handful of "future" books—scholarly radical technological inflated prophetic advice gas—which left me with a depressed feeling that the future is just words.*

*The real future will be made of much that is reported in this book (and approximately unknown to the scholars). Namely rural Third World people in newly rich economies and new planned cities, subverting the planners and transforming their own lives.*

*La Laja is a barrio in the planned Venezuelan city of Ciudad Guayana. Dr. Peattie was there for 2½ years with her family, taking part in barrio life and paying structured attention to what was going on. Social life around her was loose, fluid to a swiftly changing environment and economy. People were self-organizing only around critical community issues such as water or sewers. From the barrio it was a huge impassable distance to the planners, so when something came down that was intolerable they would beef futilely for a while and then plant dynamite under it. Nothing romantic. Just making do, getting by.*

*It sure dynamited my depression.*

Under that wide sky's bowl of light the new roads and new concrete buildings—rows of developer houses, apartment buildings, commercial structures—seem to erupt from the dusty-dry earth which bulldozers have scraped clear of vegetation. Elsewhere, the improvised housing of the poor, of sheet aluminum or pressed-board, looks as if it had been thrown together by a hurricane. It is a city of bulldozers, of engineers who wear boots and dungarees and carry shiny briefcases, of noisy bars and holes in the streets, and of new traffic interchanges; it is a city of building and of disorderly entrepreneurship; it is a city which lives in the future.

A typical La Laja house represents in its physical arrangements a kind of gradient from the more public front to the more private back, which is at the same time a gradient of relative orientation to the urban, commercial economy and to the more traditional and rural. The plastic-upholstered living-room set and the artificial flowers in a plaster vase are part of that same world which women express in their urbanized style of dress and hairdos. The kitchen with its earth floor and deal table heaped with drying dishes, its hammock in the corner, is a residue of that world from which this people is in the process of emergence. The transformation of one into the other has already gone far; for example, in La Laja the large "showpiece" stove is beginning to invade some kitchens, and almost everywhere, even among poorer families, plastic and enamelware have replaced the calabash and hollowed wood tub of the traditional countryside.



Another part of La Laja's natural environment consists of the strip of unimproved land just beyond the Iron Mines fence. This land, covered with brush and cactus, is often used for toileting, especially by children; debris may be dumped there, and children collect certain wild fruits in the brush. Some medicinal plants (from an extensive folk pharmacopeia of herbal remedies) are collected there by adults. Some men of the barrio shoot birds in this piece of monte. Boys hunt birds and sometimes rats with stones, either thrown or projected with a sling shot; their accuracy is astonishing by American standards.

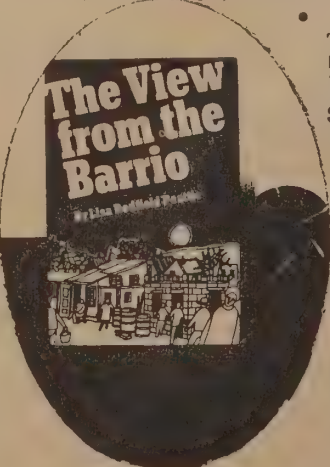

**The View from the Barrio**  
Lisa Redfield Peattie  
1968; 147 pp.

**\$6.95** postpaid

from:  
The University of Michigan Press  
615 East University  
Ann Arbor, Michigan 48106

or **WHOLE EARTH CATALOG**

# Previously listed in Understanding Whole Systems and still beloved:

## The Times Atlas of the World

The Times Survey Atlas of the World, with cartography by John Bartholomew of Edinburgh, was issued in 1921, and was recognized immediately as one of the finest atlases ever printed. The tradition has been continued, and the latest Times Atlas—the Comprehensive Edition—is the best place for an English-reading person to find where in the world something is located. The book also has a unique ability to convey the feel of the world. It measures 18" x 12 1/2" x 2", weighs 11 pounds, and contains 568 pages, of which 240 are double-page maps of superb accuracy and beauty. The index-gazetteer includes more than 200,000 entries, incomparably more than any other atlas of the world, and the entries are keyed not only by individual map coordinates, but by latitude and longitude as well (a feature offered by no other atlas). Despite the huge number of place names the maps are extraordinarily legible, and they are mercifully free of the pink-purple-yellow political emphasis offered by lesser cartographers. Some of the place names may look strange to American readers, because the atlas follows the rules of the Permanent Committee of Geographical Names. This supra-political body sensibly believes that places should be called what their occupants call them. In cases where the generic name is unfamiliar, the traditional anglicized name is also given, in parentheses.

[Suggested and reviewed by  
Dr. Morton Grosser]

**Times Atlas of the World**  
Comprehensive 1 Vol. Edition  
1968; 568 pp.

from:  
Houghton Mifflin Company  
Wayside Road  
Burlington, Mass. 01803

\$57.50 postpaid

or WHOLE EARTH CATALOG

## The World from Above

Close-up glamor shots of the Earth. Mystery shots (What is that? What's our altitude above it, 10 feet or 10,000?) (Fold out captions tell all.) Good traffic flow pattern shots: surface anatomy of civilization. Not a bad compendium; it'll do until they reprint E. A. Gutkind's Our World From the Air.

**The World from Above**  
Hanns Reich  
1966; 88 pictures

\$7.95 postpaid

from:  
Hill and Wang, Inc.  
141 Fifth Avenue  
New York, N. Y. 10010

or WHOLE EARTH CATALOG

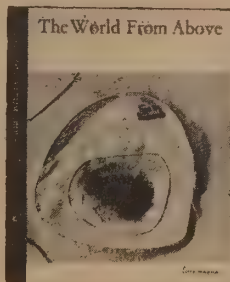

## Synthesis of Form

Christopher Alexander is a design person that other design people refer to a lot. This book deals with the nature of current design problems that are expanding clear beyond any individual's ability to know and correlate all the factors. The methodology presented here is one of analysis of a problem for misfits and synthesis of form (via computer-translatable nets and hierarchies) for minimum misfits.

[from the table of contents]

2. Goodness of Fit
3. The Source of Good Fit
4. The Unselfconscious Process
5. The Selfconscious Process

**Notes on the Synthesis of Form**  
Synthesis of Form  
Christopher Alexander  
1964; 216 pp.

\$6.75 postpaid

from:  
Harvard University Press  
79 Garden Street  
Cambridge, Mass. 02138

or WHOLE EARTH CATALOG

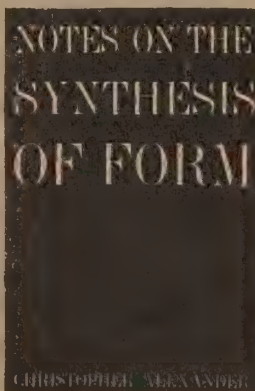

## The Ghost in the Machine

Koestler's latest book seems to be sharing the fate of Norman O. Brown's *Love's Body*: the book after the big influential one (*Act of Creation, Life Against Death*) is considered too far out, fragmented, excessive . . . and sells half-heartedly.

Nevermind. Koestler here is doing useful dirty work: savaging rat psychology, exploring broader implications of biological systems research, and foreseeing our imminent demise unless we organize our brain-use better. Which brings him to drugs. He proposes research to find a chemical which will voluntarily disengage old-brain from new-brain—the interior emotional kill-heavy unprogrammable stuff from exterior rational flexible stuff. Our paranoia is accidentally designed in, he suggests, and may be designed out.

Get to it, outlaws. No nation is going to support this research.

**The Ghost in the Machine**  
Arthur Koestler  
1967; 384 pp.

\$6.95 postpaid

from:  
Macmillan Company  
Front and Brown Streets  
Riverside, Burlington County  
New Jersey 08075

or WHOLE EARTH CATALOG

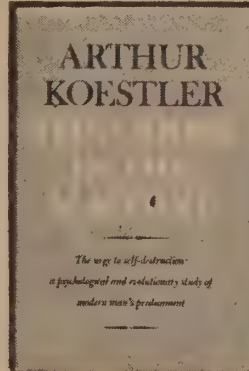

## Dover Publications

Nearly every area of study has an original madman behind it. Some guy who put his life on the line to validate his notion of the universe. His value to you is that by going straight to his writings you can get some of the original juice that may have been diluted by later doctrine. Furthermore you have access to the sidethoughts. Furthermore you have access to the side-thoughts that doctrine culls out. It fits you out better for your own pioneering than the tidy given-ness you get from 3rd generation interpreters.

Dover makes a practice of reprinting original work, kinks and all, in a wide variety of fields. If you're into a variety of things you might as well have their free catalog. For book orders they ask 20¢ extra per copy for handling; they pay postage on pre-paid orders over \$6.00.

Catalog  
free

from:  
Dover Publications, Inc.  
180 Varick Street  
New York, N. Y. 10014

## Psychological Reflections

Jung in capsules and tasting like medicine.

The selection and editing of paragraphs from Jung's writings by Jacoby is done with an informed sense of continuity, so that the book is readable in sequence or by bits.

In a world increasingly subjective, everybody is psychologists to one another. Here is one master book of tools.

**Psychological Reflections**  
C. G. Jung [ed. Jacoby]  
1945, 1953, 1961; 340 pp.

\$2.75 postpaid

from:  
Harper & Row  
49 East 33rd Street  
New York, N. Y. 10016

or WHOLE EARTH CATALOG

The man who would learn the human mind will gain almost nothing from experimental psychology. Far better for him to put away his academic gown, to say good-bye to the study, and to wander with human heart through the world. There, in the horrors of the prison, the asylum, and the hospital, in the drinking-shops, brothels, and gambling hells, in the salons of the elegant, in the exchanges, socialist meetings, churches, religious revivals, and sectarian ecstasies, through love and hate, through the experience of passion in every form in his own body, he would reap richer store of knowledge than text-books a foot thick could give him. Then would he know to doctor the sick with real knowledge of the human soul.

## Purposive Systems

You're a purposive system. So am I. We're very good at it, and not as good as we'd like to be. Humanity, as a whole, is lousy at it, and worried. This collection of recent cybernetic thoughts can cheer you up and give you better concepts to worry with.

We have not yet built into our educational system any recognition of the points where precision is essential, and yet we are living in a society where one mistake can dislocate the lives of thousands of people, wreck distribution systems, and distort life-history data, and subsequent career lines.

A friend of mine once gave what I regard as a nice shorthand formula. When in a dilemma, introduce novelty.

**Purposive Systems**  
Ed.: Heinz von Foerster, J. D. White,  
L. J. Peterson, J. K. Russell  
1968; 179 pp.

from:  
Spartan Books  
432 Park Avenue South  
New York, N. Y. 10016  
or WHOLE EARTH  
CATALOG

\$10.00 postpaid

## Aspects of Form

This is a well-used collection of insights by venerable initiates of form study.

**Aspects of Form**  
Lancelot Law Whyte, ed.  
1951; 249 pp.

from:  
Indiana University Press  
10th and Morton Streets  
Bloomington, Ind. 47401

\$1.95 postpaid

or WHOLE EARTH CATALOG

## Tantra Art

For any one interested in Yantra, Mandalas, Archetypal art, "Objective" art this book is invaluable. Incredible color and B&W reproductions of works not usually available or attainable. This book will become a standard dictionary for "objective" language study.

[Suggested by Ann Hogle.  
Reviewed by Steve Durkee]

**Tantra Art**  
Ajit Mookerjee  
1966; 100 pp.

\$32.50 postpaid

from:  
Shambala Booksellers  
2482 Telegraph  
Berkeley, CA 94704

or WHOLE EARTH CATALOG



## A YEAR FROM MONDAY



**A Year From Monday**

A Year From Monday  
John Cage  
1963; 167 pp.

\$1.95 postpaid

from:  
Wesleyan University Press  
Middletown, Conn. 06457

or WHOLE EARTH CATALOG

## General Systems Yearbook

**General Systems, Vol. 13**  
Ludwig von Bertalanffy, Anatol Rapoport,  
Richard L. Meier, eds.  
1968; 212 pp.

\$10.00 postpaid

from:  
Society for General Systems Research  
Joseph Henry Building, Room 818  
2100 Pennsylvania Avenue, N. W.  
Washington, D. C. 20006

# Shelter and Land Use

Edited by Lloyd Kahn.

## Geodesics

Finally, a book for dome builders, with good pictures, clear drawings, and introductory text on the basic principles of Fuller's geodesics.

Domes of metal, wood, plastic, canvas, and along with the pictures of various types are detailed sections of hubs, construction methods, and different geometries.

Chord factors—the constants necessary for calculation of different diameter domes—are given, but are a bit more complex than the simple three-frequency Sun Dome (See p. 39).

Domer Steve Baer adds:

A book about geodesic domes. Half a dozen pages of text and about 90 pages of illustrations. Angles and edge length ratios are given in some instances. The illustrations are beautiful. They are good for a designer's brain—they will show a final form and then also the form's childhood by pinpointing pts. of symmetry from which patterns grow.

[Suggested by ONYX]

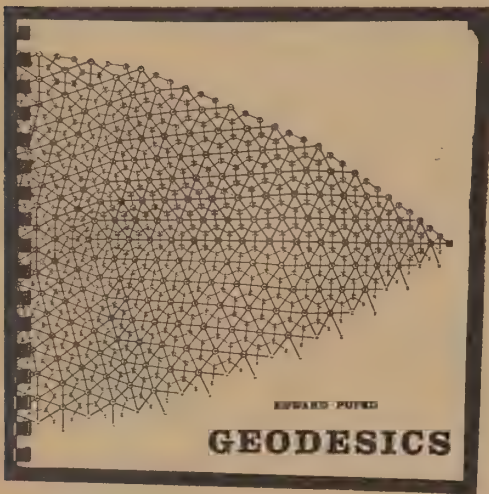

Geodesics  
Edward Popko  
1968; 124 pp.

from:  
University of Detroit Press  
4001 West McNichols Road  
Detroit, Mich. 48221

\$4.00 postpaid

or WHOLE EARTH CATALOG

The term geodesics is a contemporary geometric title ascribed to the arcs on a spherical surface which represent the shortest distance between any two points on that surface. When applied to architectural spanning devices it becomes, "... a frame of generally spherical form in which the main structural elements are interconnected in a geodesic pattern of approximate great circle arcs intersecting to form a three-way grid, ..."

## Space Grid Structures

A space grid is a means of spanning great distances with little weight, and few intermediate supports. Buckminster Fuller's Octetruess at the Museum of Modern Art in 1959 was 35' wide and spanned 60' one way, 40' another from one column of supports. It was fabricated of 2" pipe.

Space grids consist of two parallel planes, forming a floor and ceiling; 'web' members in between connect them in such a way that external loads are distributed in all directions.



Space Grid Structures by John Borrego

Skeletal Frameworks and Stressed-Skin Systems

This book is "...an exchange of information about what has been done recently in the development of flat space grid structures." There are photos, drawings, models of structures and joints. The three sections of the book deal with flat double-layer space grid structures, stressed-skin space grids, and fine clear drawings of space grid geometries. Also an extensive bibliography. Very little text; it's not needed as the drawings and photos are excellent.

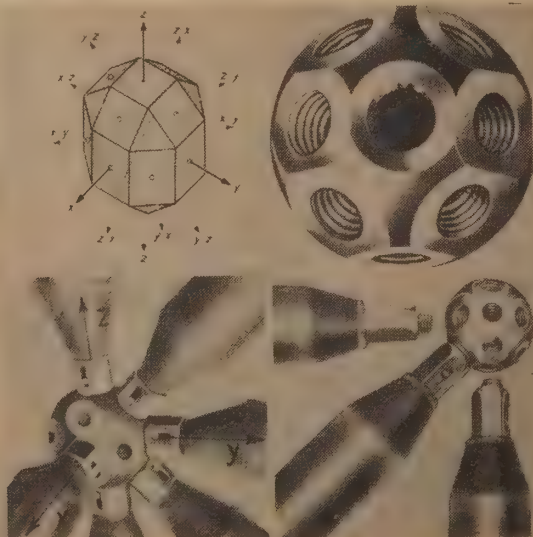

Space Grid Structures  
John Borrego  
1968; 200 pp.

\$12.50 postpaid

from:  
The M. I. T. Press  
Room 765  
50 Ames Street  
Cambridge, Mass. 02142

or WHOLE EARTH CATALOG

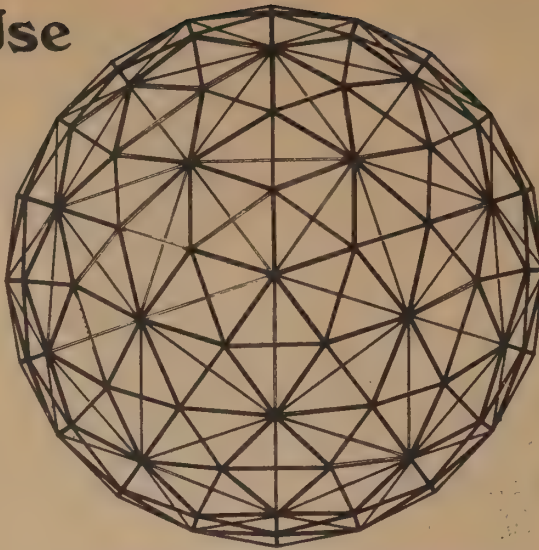

Fig. No. 34 Plan. Dome consists of an outer structural framework and interior membrane suspension. Fifty-five diamond units and ten half-diamond base pieces make up outer frame. Total erection of dome including membrane is about three man hours.

Although somewhat basic, it is necessary in our development from polyhedra to spherical structures to point out that spherical bodies may orientate themselves in an infinite number of positions in space. In dealing with domes, however, only three basic conditions are considered: edge, face and vertex zenith. In the combined sphere (icosahedron, dodecahedron, rhombic triacontahedron), the heavy rhombic triacontahedron diamonds, the long axis of which delineates the icosahedron and the short axis the dodecahedron, indicate the basic orientations.

To this point our concern has primarily been with basic icosahedral forms and their related duals. We have chosen to limit ourselves to this category of geometry for this family offers the greatest degree of regularity when translated into spherical structures of which member length and joinery conditions become factors.

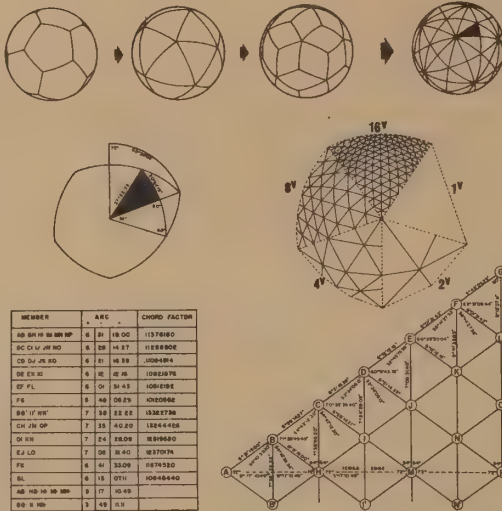

Fig. No. 7 Top: Cumulative superposition of dodecahedron, icosahedron, and rhombic triacontahedron to achieve smallest common triangle. Mid-page: Basic spherical triangle, multiple frequency comparison. Bottom: Typical geometrical data for 12° Triacon breakdown. Same chart is good for 3° Triacon eliminating unnecessary members. New chord factors are needed.

## Fuller Patents

Fuller's first patent on geodesics is so complete that it's framed in glass in the U. S. patent office.

Available from the government, 50¢ each, are intricately detailed descriptions of the designs that have yet to be fully realized.

The primary patent, filed in 1951—"Building Construction"—describes the derivation of the geodesic dome from the icosahedron, and includes a description of space grid domes for spanning over 140'.

"Laminar Geodesic Dome" gives chord factors for a 4-frequency diamond panel dome, and tells you how to use the panels to make a tunnel geodesic of any length.

Patent No.	Title
2,682,235	Building Construction
3,203,144	Laminar Geodesic Dome
2,905,113	Self-strutted Geodesic Plydome
2,914,074	Geodesic Tent
3,197,927	Geodesic Structures

50¢ each from:  
U. S. Patent Office  
Washington, D. C.  
20402

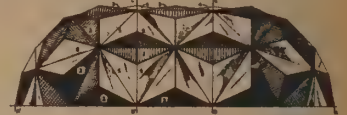

A good index to the performance of any building frame is the structural weight required to shelter a square foot of floor from the weather. In conventional wall and roof designs the figure is often 50 lbs. to the sq. ft. I have discovered how to do the job at around 0.78 lb. per sq. ft. by constructing a frame of generally spherical form in which the main structural elements are interconnected in a geodesic pattern of approximate great circle arcs intersecting to form a three-way grid, and covering or lining this frame with a skin of plastic material.

My "three-way grid" of structural members results in substantially uniform stressing of all members, and the framework itself acts almost as a membrane in absorbing and distributing loads. The resultant structure is a spidery framework of many light pieces, such as aluminum rods, tubes, sheets, or extruded sections, which so complement one another in the particular pattern of the finished assembly as to give an extremely favorable weight-strength ratio, and withstand high stresses.

In dealing with the great range of conditions that the dome must geometrically satisfy (span and height most commonly) it becomes readily apparent that the basic icosahedron cannot remain in a pure state. This brings us to the matter of a geometrical breakdown. This can best be described as an attempt to expand the icosahedral form to satisfy the space requirements and allow the components from which it is made to remain within structural fabrication and erection limits.

I have found that if the structural members be aligned with the lines of the grids, the resulting framework will be characterized by more uniform stressing of the individual members than is possible with any construction heretofore known.

Also I have found that a very special relationship exists between a geodesic building structure made of interconnected struts and a complementary geodesic building structure made of flexible fabrics or plastic skins where these two structural components are made to conform in structure, pattern or behavior to a mutual three way great circle synergy. My present invention is concerned with an improved geodesic skin or tent construction which gives a new and synergetic stress distribution—synergetic in the sense that the behavior of the skin under stress is unpredicted by its several parts, and that there is imparted to the structure a strength beyond that which would be calculated using accepted values of strengths of materials and usual methods of stress analysis and computation.

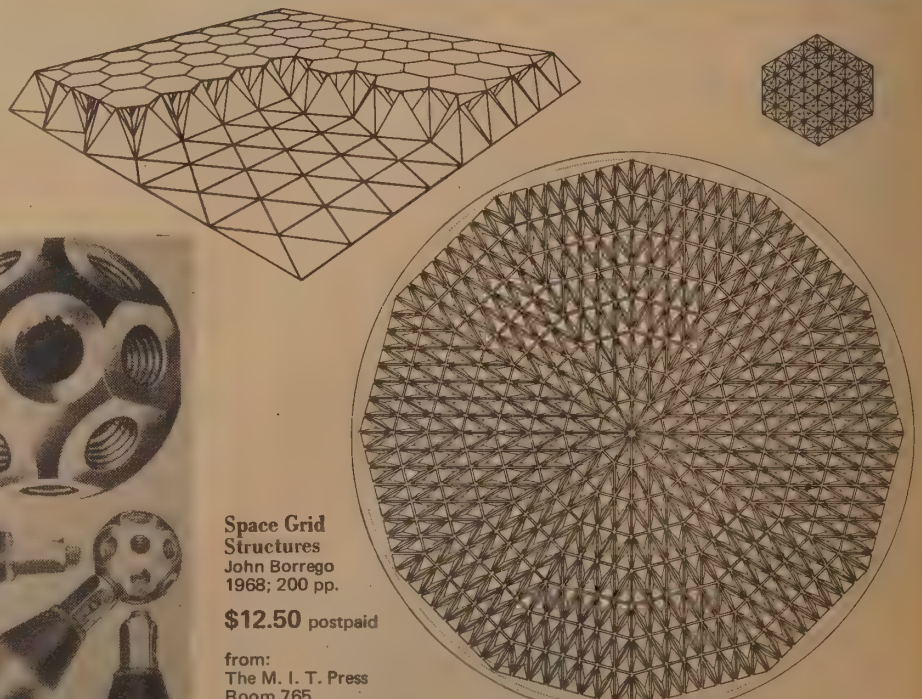
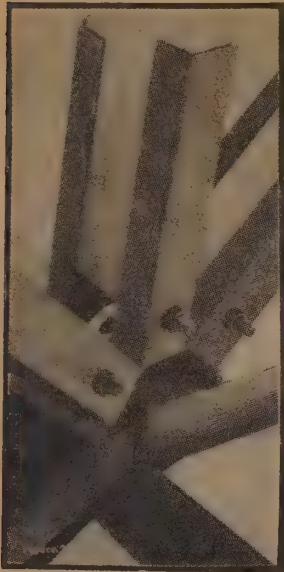

Photo 100  
The reflected ceiling plan of the roof for the church at Des Moines, England, by Arthur Langlois and Partners. Structural design by Space Structures Research Ltd 2 S. Maxwells, structural contractor. The roof has 12 segments each made up of 64 slumped triangles. Details on Page 110.

## Dyna Domes

There are about a dozen Dyna Domes on the outskirts of Phoenix. Each new one built gets a little closer to the city limits, and it's the hope of domebuilder Bill Woods to have the city fathers wake up one morning, find themselves surrounded by domes, and admit the new creatures under the wings of the building codes.



These are good quality, low cost plywood domes, with fiberglass exterior, and polyurethane foam insulation sprayed on the inside. Wood struts are put together with patented metal connectors, seams are filled with high-strength caulk, then taped with fiberglass.

You have the choice of having a dome erected (within 500 miles of Phoenix), buying a kit, or purchasing just the connectors with plans.

Woods has been experimenting for some time with foam-fiberglass buildings, has built a machine that produces the sandwich panels, and is about to market a foam dome.



Complete dome, erected on concrete floor within 500 miles of Phoenix: approx. \$4.00 per sq. ft. floor space.

Complete kit with instructions for erection: approx. \$2.00 per sq. ft. floor space.

Hub connectors, with plans for building it yourself: \$2.00 per strut.

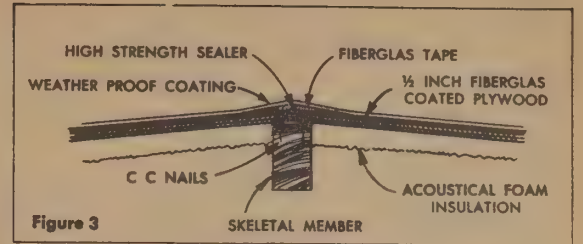
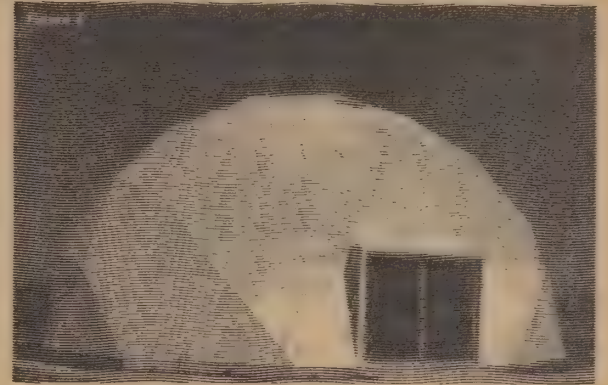

Figure 3

Brochure free from:  
Dyna Dome  
22226 North 23rd Avenue  
Phoenix, Arizona 85027



## Zomeworks

Zomeworks builds structure systems, structures, solar energy collectors and systems, and glamour. From their desert base near Albuquerque they are shortly blossoming into an industry. Something I'm considering at present is whether to personally invest in that growth.

—S. B.

For design, fabrication, consulting, lectures, write:

Zomeworks Humanfactory  
Box 445  
Corrales, New Mexico 87048

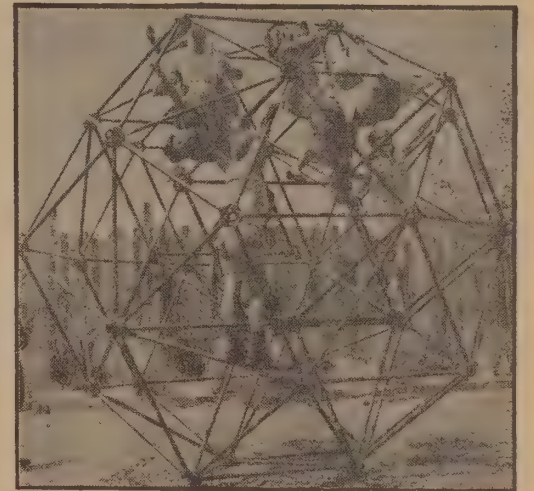
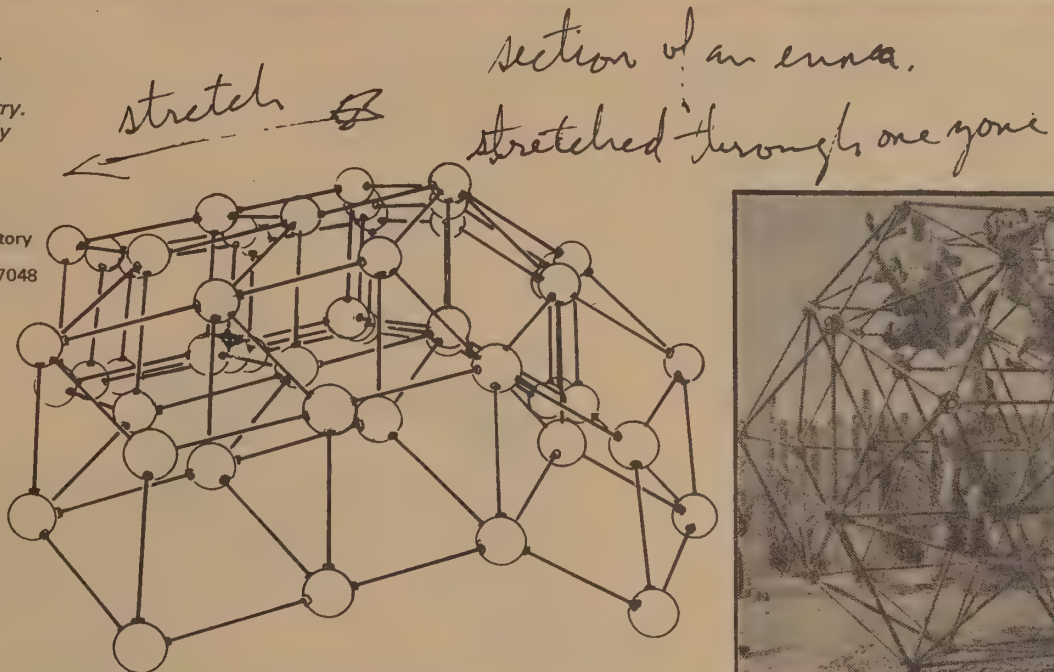
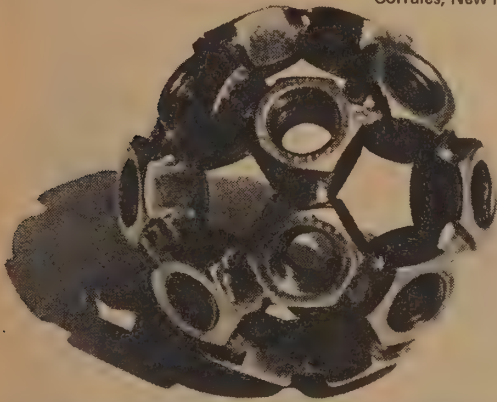

## Futuro

It's interesting that Finland, with its extensive forests and finely-crafted wooden structures, should present the first well-detailed commercially available foam-fiberglass dwelling. Called Futuro, this gleaming elliptical pod with retractable stairs, looks like it just landed. Now in production in Philadelphia and slated for west-coast production in San Jose, the lightweight home can be helicopter-dropped, and requires no site preparation. Structural strength and insulation are outstanding features. The interior furnishings (optional) look plastic and shiny—perhaps the direction that future housing will take.



The Futuro House is now on display at 20th and Parkway, Philadelphia.

Futuro House

\$10,000 for shell  
\$14,000 for completely equipped house  
F. O. B. Philadelphia

from:  
Futuro Corporation  
1900 Rittenhouse Square  
Philadelphia, PA 19103

### FUTURO FACTS

1. 100% insulated 2" polyurethane foam—heats from -22 to 72 F. in 30 minutes.
2. Positive pressure ventilation system—air conditioning available.
3. Complete kitchen facilities.
4. Bathroom facilities with shower and either chemical or standard water closet.
5. Internal partitions can be modified to sleep up to eight people in one unit or can be divided into two double bed motel units, or supplied bare, except for water closet. Furnishings include 6 convertible chaise/beds, lighted arm rests, center table, barbecue, fireplace, carpets, partitions, shelves, etc.
6. Interior and exterior are made of fiberglass, including furnishing (except for carpeting). Estimated life span in excess of 30 years.
7. Almost completely maintenance free for life of unit.
8. Exterior colors available: Pale blue, pine forest green, pale pink, lemon yellow. Interior decor complements exterior.
9. Snow load in excess of 10 feet; wind load over 100 miles per hour, sealed against all water, dust or air infiltration.
10. Gross weight about 8000 pounds; diameter 26 feet; internal height at center—11 feet; effective area at window height—500 square feet; volume—5000 cubic feet; supporting structure—steel tubing with legs proportioned for 0 to 20 site slope.

11. No site preparation whatsoever, except for concrete piers to bolt down legs (plus utilities to site). Special independently operated utilities for more remote areas.
12. Designed for maximum security when stairs are retracted.
13. Twenty double acrylic windows—optionally operable. Viewable windows can be placed in either lower or upper hemisphere.
14. Portable (assembled) by helicopter or barge.
15. Portable (disassembled) by truck or rail.

ZONING AND BUILDING CODES—Futuro is available for Class I or II Fire Ratings and will be suitable for sparsely developed areas, or those conforming to National Building Codes.

TYPICAL SHIPPING COSTS—(f.o.b. Philadelphia)—Helicopter assembled about \$1000 per 100 miles. Car or Truckload disassembled varies. West Indies—Barge and Helicopter at Island \$3,000 assembled.



★  
Design with Nature

To assert man's supremacy over nature is an underlying western attitude toward the universe. It is embodied in a value system through which man seeks not unity with nature but conquest. When nature is given special consideration, it is usually for the purpose of exploitation, which not only achieves the underlying objective to conquer but also provides a financial reward for the conqueror.

Ian McHarg's book is a tool for those who want to demonstrate how man can design with nature, rather than against it.

To those who are fighting the Philistines, McHarg says it is best to argue against them not with a bleeding heart but with a rudimentary knowledge of ecology. For dealing with highwaymen, he prescribes a mapping technique by which psysiographic corridors containing the lowest social values can be identified as the preferred routes for highways.

To those who are starting new communities in the rural hinterland, he demonstrates an ecological method to determine which lands are most tolerant to urbanization.



To those working to solve city problems, he demonstrates the application of the ecological view to the problem of distributing open space in a metropolitan region. He recommends the creation of urban airsheds as responses to atmospheric pollution control and microclimate control. These airsheds should be in vegetative cover—preferably forested—and should create fingers of open space penetrating from the rural hinterlands, radially into the city.

McHarg's book is happily uneven. Technical passages are moderated by philosophy and history. Fables alternate with case studies. Time spins from astronauts to algae. In one episode, the total beautiful process of nature is quickly grasped after the bomb when the algae look around and agree, "Next time, no brains".

McHarg's personal style makes it fun to learn the ecological view—everyone can relate to at least part of what he says and piece together an individual interpretation of

the first lesson needed for life here: that the earth is a creative process, that man has a unique creative role, that all physical and living processes are arresting energy on its path to entropy and, in so doing, are creating a self-perpetuating and evolving system. Man shares this process; it contains his history. He is here now in this phenomenal universe with his indispensable partners in survival and creation. This is the central lesson of the workman's code in the manual of the good steward.

[Reviewed by Beatrice Farrar Ryan]

One cannot predict the fate of such a book as this. But on its intrinsic merits I would put it on the same shelf that contains as yet only a handful of works in a similar vein, beginning with Hippocrates, and including such essential classics as those of Henry Thoreau, George Perkins Marsh, Patrick Geddes, Carl Sauer, Benton MacKaye, and Rachel Carson. This is not a book to be hastily read and dropped; it is rather a book to live with, to absorb slowly, and to return to, as one's own experience and knowledge increases. Though it is a call to action, it is not for those who believe in "crash programs" or instant solutions: rather, it lays a fresh course of stones on a ground plan already in being. Here are the foundations for a civilization that will replace the polluted, bulldozed, machine-dominated, dehumanized, explosion-threatened world that is even now disintegrating and disappearing before our eyes. In presenting us with a vision of organic exuberance and human delight, which ecology and ecological design promise to open up for us, McHarg revives the hope for a better world. Without the passion and courage and confident skill of people like McHarg that hope might fade and disappear forever.

Lewis Mumford

This book is a personal testament to the power and importance of sun, moon, and stars, the changing seasons, seedtime and harvest, clouds, rain and rivers, the oceans and the forests, the creatures and the herbs.

PHENOMENA	RECOMMENDED LAND USES
Surface water and riparian lands	Ports, harbors, marinas, water-treatment plants, water-related industry, open space for institutional and housing use, agriculture, forestry and recreation.
Marshes	Recreation
50-year floodplains	Ports, harbors, marinas, water-treatment plants, water-related industry, agriculture, forestry, recreation, institutional open space, open space for housing.
Aquifers	Agriculture, forestry, recreation, industries that do not produce toxic or offensive effluents. All land uses within limits set by percolation.
Aquifer recharge areas	As aquifers.
Prime agricultural lands	Agriculture, forestry, recreation, open space, housing at 1 house per 25 acres.
Steep lands	Forestry, recreation, housing at a maximum density of 1 house per 3 acres, where wooded.
Forests and woodlands	Forestry, recreation, housing at densities not higher than 1 house per acre.

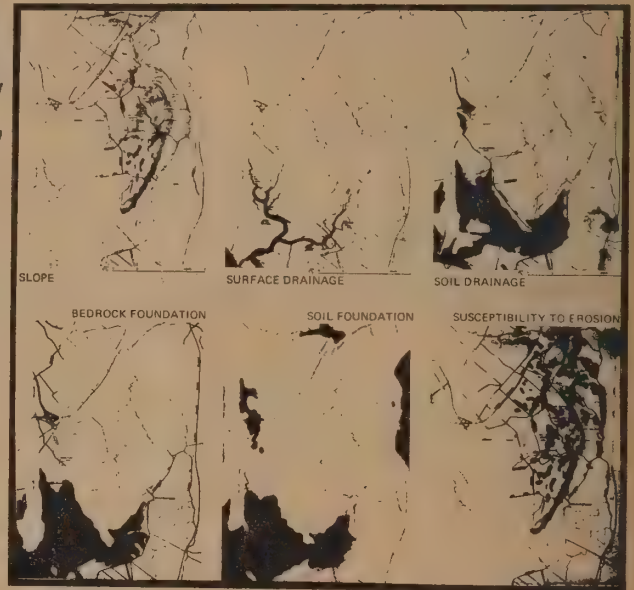

These indispensable creatures, performing their vital role in the nitrogen cycle, deserve to be household words, man's great heroes. Yet sadly those who named them had no thought of public honor and familiarity and called them Azotobacter and Clostridium, Rhizobium and Nostoc.

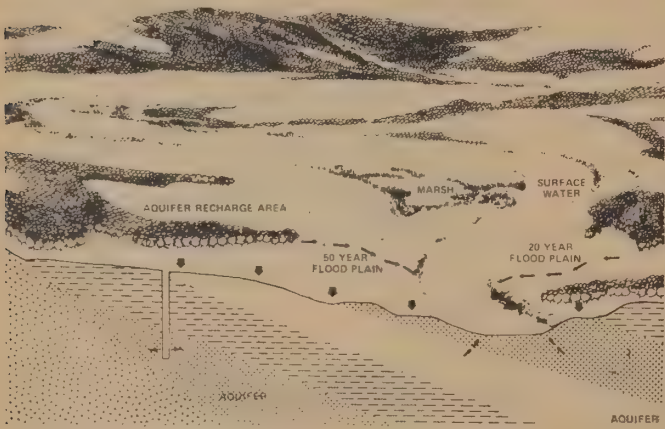

**Design with Nature**  
Ian L. McHarg  
1969; 197 pp.  
**\$19.95** postpaid  
from: The Natural History Press  
501 Franklin Avenue  
Garden City, New York 11530  
or **WHOLE EARTH CATALOG**



George Wald once wrote facetiously that "it would be a poor thing to be an atom in a Universe without physicists. And physicists are made of atoms. A physicist is the atom's way of knowing about atoms." Who knows what atoms yearn to be, but we are their progeny. It would be just as sad to be an organism in a universe without ecologists, who are themselves organisms.

**Architecture Without Architects**  
A Short Introduction to Non-Pedigreed Architecture



**20** *Troglodyte caverns, 40 feet high treehouses, sculptured Iranian sail vaults; rare photos of man working in conjunction with nature. A book for architects and builders to meditate upon.*



**Architecture Without Architects**  
Bernard Rudofsky  
1964; 160 pp.  
**\$3.95** postpaid  
from: Doubleday & Company  
Garden City, N. Y. 11531  
or **WHOLE EARTH CATALOG**

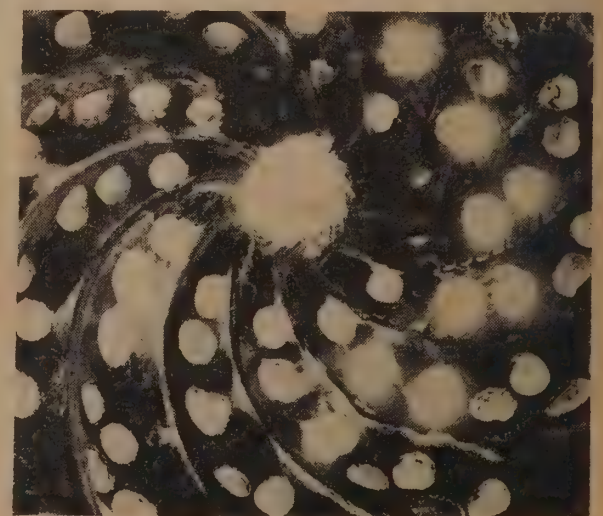

Cupola of a Turkish bathhouse—a whirlpool of bright stars, arrested, as it were, in its movement. The luminous disks embedded in the dome are thick, lenslike glass blocks. Iznic, Turkey. Ottoman period.

**Tensile Structures, Volume One**

The only pavillion of Expo 67 more beautiful than Fuller's U. S. Dome was the West German tent, designed by Frei Otto. He is currently the master of structures whose flexible skin is the prime structural element. Volume One of his 2-volume work is devoted to *Pneumatic Structures—air houses plus*. Every designer we know who's seen this book has commenced to giggle and point, jump up and down, and launch into enthusiastic endorsement of Otto, design, being a designer, and look at this here. The book is comprehensive in its field, technically thorough, beautifully presented.

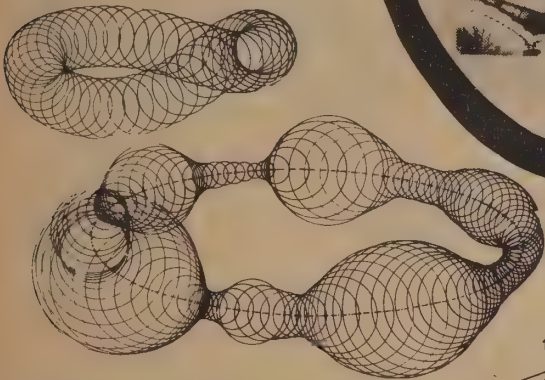

The saddle surface of the inside part has a smaller area than the outside, which is not a saddle surface. The torus differs from all other pneumatically tensed membranes by this characteristically saddle-shaped region. The circle on which the spheres forming the torus are strung need not be in the same plane, nor need the spheres have equal diameter. Here, too, unlimited variations are possible, subject to the general laws of formation, and to those particular to closed hoses.

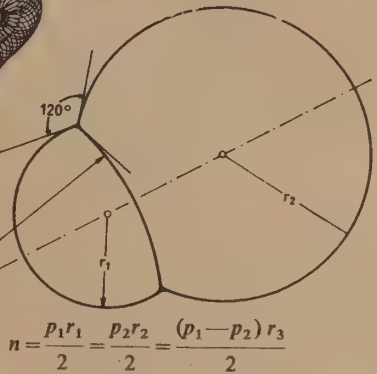
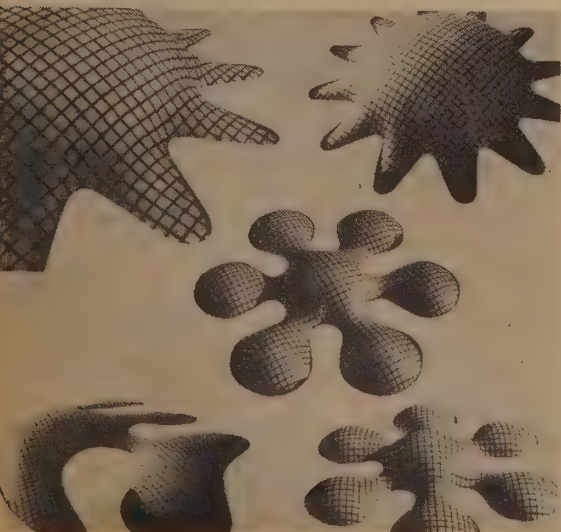
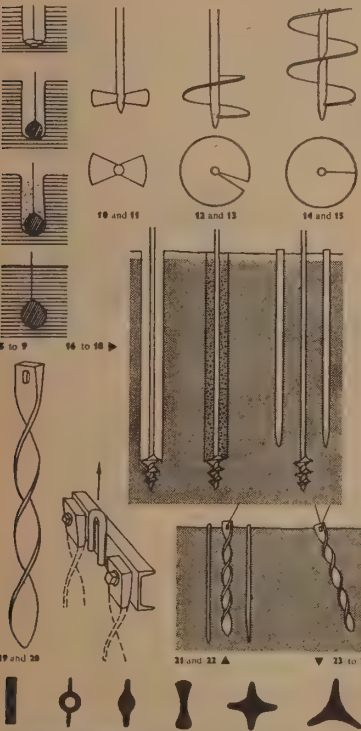

If two soap bubbles of different diameters form a twin bubble (Fig. 10), the diaphragm is curved. If the membrane stresses are equal, the gas pressure  $p$  in the smaller bubble is higher than that in the larger bubble. The relationship between the radii  $r_1, r_2, r_3$ , is given by:



Guyed masts consist of one-dimensional central elements subjected to compression and surrounded on all sides by one- or two-dimensional tension-loaded elements. They thus form three-dimensional systems most suitable for mobile structures. Many contemporary designs of high cranes for wide reaches are variations of this basic system. An elastic central rod can be bent by varying the lengths of the guys (Fig. 3). For this, all cables must be adjusted simultaneously; this is done by synchronized hydraulic presses located at the anchoring point. A similar, but much more mobile system is shown in Fig. 4. A thin elastic central strut carries cantilevers connected to the ground by means of cables.

In living nature the spine of a vertebrate (Fig. 7) is a geyed mobile system, approximately as shown in Fig. 4. A multiple articulated, highly flexible central rod, capable of taking up large compressive forces, is surrounded by a tension-loaded system consisting of many members, which secures the central rod against buckling and bending, while ensuring its complete mobility.



**Tensile Structures, Volume Two**

*Tensile structures is the complete story on tents and cable nets like volume one the entire subject is covered in minute detail. The book is intended to show where the thinking and practice on the subject is at this time in history. There is an overview of the whole field, then specifics on cable, net and membrane structures. Each is thoroughly discussed and illustrated with photographs and drawings although graphics here are not as intriguing as in volume one. The last third of the book contains calculations on load-bearing abilities and design. For many readers this will be too technical to understand, much less use. But tensile structures are very exciting at this time, and the book is great for getting people started on experiments and construction. Canvas is a cheap building material. There's a lot to learn here. The forms are very organic, and coverage is complete.*

[Reviewed by Jay Baldwin]

**Tensile Structures, Vol. Two**  
Cables, Nets and Membranes  
Frei Otto  
1969; 171 pp.

\$12.50 postpaid

**Tensile Structures, Vol. One**  
Pneumatic Structures  
Frei Otto  
1967; 320 pp.  
1660 illustrations

\$22.50 postpaid

both from:  
The M. I. T. Press  
50 Ames Street  
Cambridge, Mass. 02142

or WHOLE EARTH CATALOG

Curved Membranes and Cable Nets Stretched between Cables



Experiments were undertaken in the years 1960-64, in which soap films were stretched in different frames and measured photographically in order to determine their shape.

A soap film can be stretched in any frame consisting of straight or curved components, provided that it forms a closed line. The film then forms a continuous surface, the frame being subjected to bending.

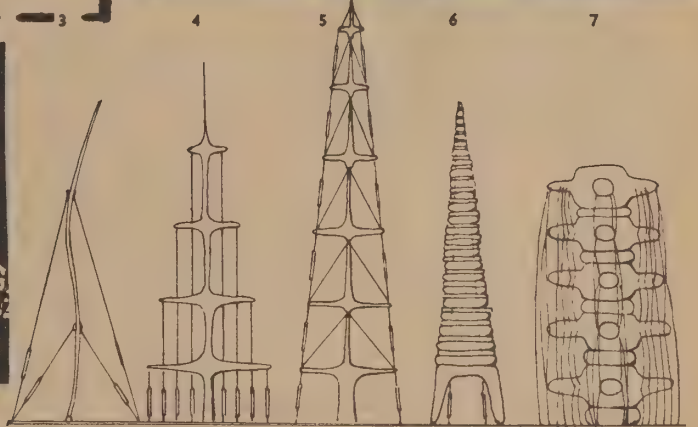
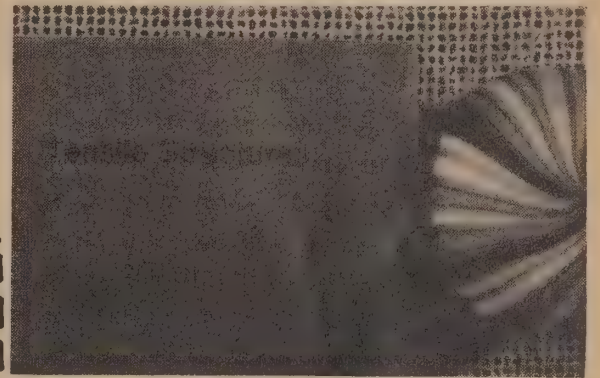

## The Owner-Built Home

Ken Kern makes a unique offer to anyone thinking about building his own home: for \$10 he furnishes a preliminary house design, as well as a copy of *The Owner-Built Home*, which is about the most useful book on building available.

For the design, send him a sketch of your building site, along with space requirements and personal likes and dislikes; or you may prefer to get the book first and read the first chapter on "Site and Climate" before sending in the information.

The book is sound advice on the best low-cost building techniques from around the world: Africa, India, Israel: countries that cannot afford U.S.-style waste. Much of it is not in print elsewhere.

A 1" concrete floor with loading stresses of 450 lbs per sq ft; houses built of earth, woven bamboo and bottles, as well as of conventional materials. How to hook up your plumbing in a simple central core.

Good dope on concrete-proportions, additives such as sawdust or emulsified asphalt for 'comfort cushion' floor. Details on wood framing, how stud wall houses are overbuilt, the strength of threaded nails.

There is much good data on building with rock and earth; how to make a sliding form for rammed earth and a discussion of the strength of rammed earth and soil cement. Why don't you hear anything these days about earth wall buildings?

Inasmuch as there is nothing in bare earth to sell, no commercial group can be found to extol its merits.

Lots more, with a bibliography at the end of each chapter for further research. Kern is currently adding new sections to the book: homemade fireplaces, construction tools, and utilizing salvage materials.

From the point of view of glare-control, the customary practice of placing the kitchen or bathroom window over the sink is ill-founded. The object requiring our attention should be the brightest thing in view. When something else is brighter, such as a glossy painted surface or a sink window, then a conscious effort is required to concentrate on the object requiring attention. Ability to see is thereby reduced, since our eyes will be adjusted to the brighter surface. A sink in a kitchen or bathroom should be placed so that the light from the window will come from the side or from the top, and not from the front.

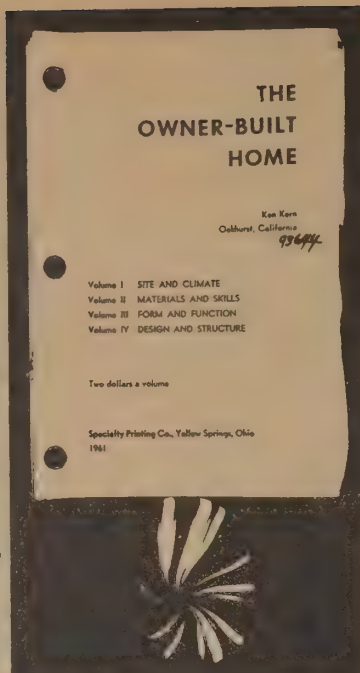

**The Owner-Built Home and preliminary house design** (send sketch, etc.)  
Ken Kern  
1961; 300 pp.

**\$10.00** postpaid

from:  
Ken Kern Drafting  
Sierra Route  
Oakhurst, CA 93644

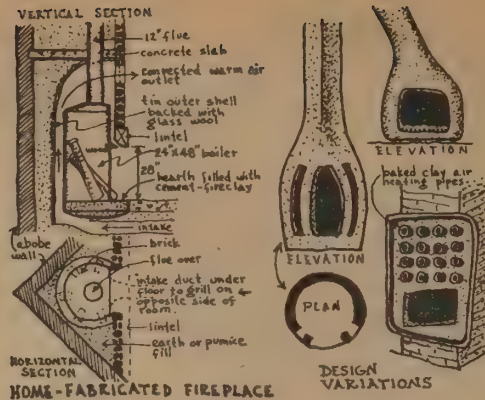

We come, thirdly, to the admixture of ventilating currents with combustion products. Count Rumford was the first to give extensive study to inside-fireplace proportions. His final rule-of-thumb is that the back of the fire-space should be equal to the depth of the recess. Deep fuel beds produce more smoke than the grate. Experience proves that the rate of smoke-emission increases proportionally with the depth of the firebox, especially in the early stages of firing.

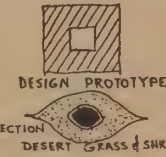
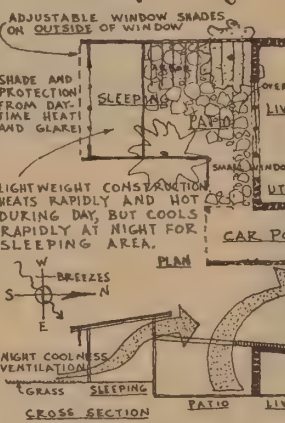
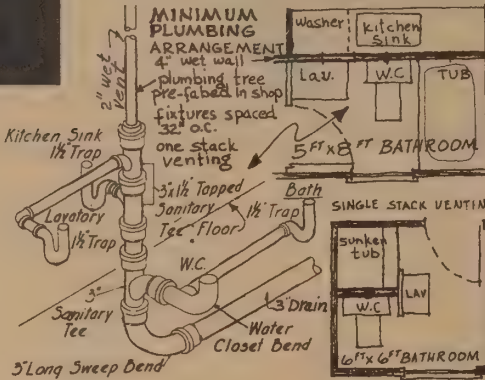

Ideally, the best guarantee against capillarity is a continuous air space between floor and ground. A low cost floor of this nature was developed a few years ago by Dr. Billig of the Central Building Research Institute, India. Although described as a light duty floor, it was subjected to loading stresses up to 450 lbs. per square foot without showing any sign of distress. (Most building codes in America require a 30 to 50 lb. per square foot minimum, but in conservative residential occupancy the furniture loads seldom exceed 15 lbs. per square foot, uniformly distributed.) The CBRI floor consists of a one-inch thick lightly reinforced concrete slab, resting on plunger piles. To make a hole for a pile a crowbar is driven into the ground to a depth of three feet. The hole thus made is then filled with fine concrete. The slab consists of two layers of concrete, each 1/2-inch thick, spread over Hessian, a form of burlap. After a few weeks the loose earth filling settles and an air space is formed under the slab which finally rests on the concrete piles. An effective heat insulation results; the floor is cool in summer and warm in winter.

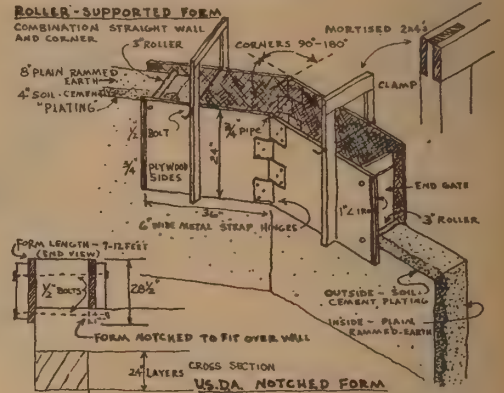

This book is being written in a rammed earth studio that I built four years ago. During the planning stages I made a study of numerous types of wall forms; then improvised on some of the more salient features. I ended up with a type of roller-supported plywood form that can be adjusted to fit any corner.

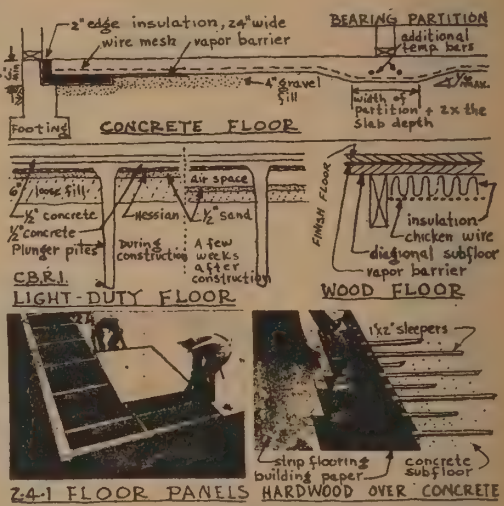

## Your Engineered House

"To begin this book, and the day, what does it take to get the morning sun into the kitchen?"

A delight to read before designing or building your own home. General ideas on light, heat ventilation, house placement, acoustics, financing. Specific building tips on all aspects of building but mainly post and beam houses.

This is an easy way for a beginner to frame a house (as opposed to stud-wall construction), and it gets a roof over your head right away to keep the rain off while you finish the walls. Most of this information is seldom considered by architects, and is culled from the author's building experiences. You are encouraged and told how to pick up pencil and paper and design your own home—tailormade to your own specifications, aspirations, and finances, and, although not in great detail, how to build it yourself. A discussion and treatment of homes as human environments and a good place to start if you have no design or building experience. [Suggested by Paul Wingate]

The difference in angle between winter sun and summer sun is a tool which remains unchanged, costs nothing, and can work enormously for your comfort. The amount of difference in angle depends on how far north or south of the equator you live, but for almost all of us there is a useful difference which can be put to work keeping us cool in summer and warm in winter. The angles sketched here are for an average location in a temperate zone—say, Pennsylvania.

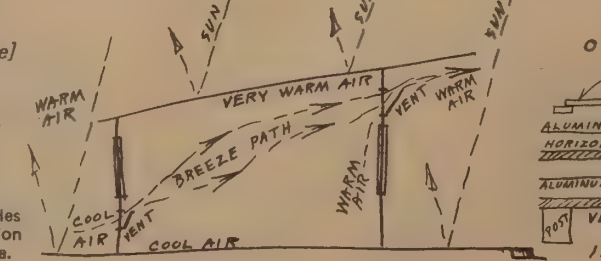
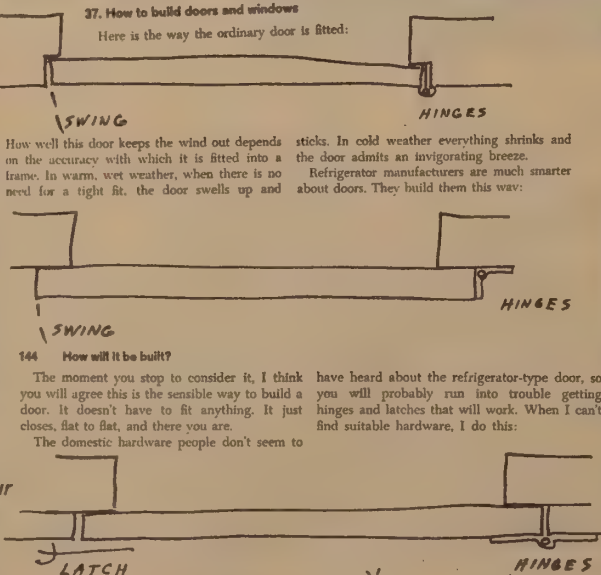

**Your Engineered House**  
Rex Roberts  
1964; 237 pp.

**\$8.95** postpaid

from: J. P. Lippincott Company  
East Washington Square  
Philadelphia, Pa. 19105

or WHOLE EARTH CATALOG

Scenery is what you see from where you live. If your scenery is to cost you nothing, you will leave it where it is, and if that scenery already has character, you will make only minor modifications. You will move yourself around, move the house around, but you will not move the scenery around until you have lived with it for a while as it is.

As a machine designer, I say that when we treat the window as a machine, asking it to perform multiple functions—admit light, admit air, or exclude it according to the weather, keep out bugs in summer, never mind the bugs in winter—and do all this at the twist of a crank without leaking or sticking—the window is bound to become expensive.

If we give the window one function and one only, to admit light, we can have all the windows we want at no extra charge. It is inexpensive to fix panes of glass permanently in place. Any smart carpenter can build a wall of glass about as quickly as he can build a wall of anything else.

As for the ventilator, it's a wooden door on the simplest of hinges, rigid, unbreakable, easy to weatherstrip, easy to screen. One frame does the whole job.

If we keep windows and ventilators separate, we wind up with more light, better ventilation, less trouble, less maintenance, and lower cost.

If I am doing work with my hands, and am right-handed, I will prefer the major light source to be at my left and the minor source at my right. If I am left-handed, I will of course reverse the sources.

The habit of building a house in a certain way is not proof that the habit should be continued. Many of our present building methods are wrong, expensively wrong. I have tried to suggest building techniques which are inexpensively right.

## House Carpentry Simplified

Clear how-to-do-it instructions on rectilinear house building. Reasonably current but not overly detailed, with a good section on fundamental tools and a glossary.

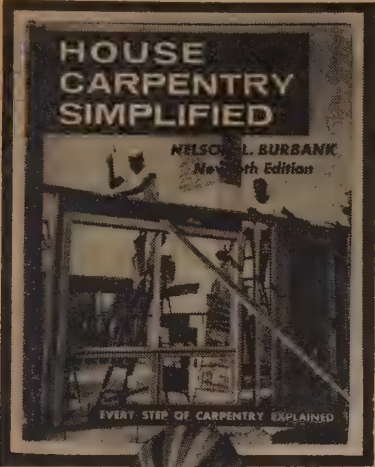

**House Carpentry Simplified**  
Nelson L. Burbank  
1958; 252 pp.

**\$8.95** postpaid

from:  
Simmons-Boardman Books  
30 Church Street  
New York, N. Y. 10007

or WHOLE EARTH CATALOG

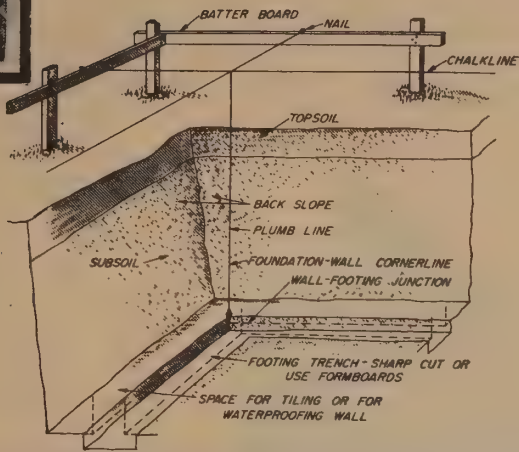
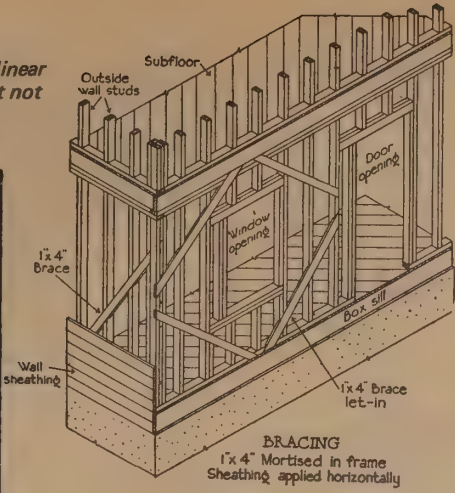

## Simplified Carpentry Estimating

When building, you'll do well to pre-calculate all materials and ask local lumber yards for competitive bids. This handbook, with short-cut tables, helps you quickly estimate all materials for conventional buildings: concrete, lumber, hardware, as well as labor hours.

**Simplified Carpentry Estimating**  
J. Douglas Wilson and Clell M. Rogers  
1962; 320 pp.

**\$5.95** postpaid from:

Simmons-Boardman Books  
30 Church Street  
New York, N. Y. 10007

or WHOLE EARTH CATALOG



## Various Concrete Forms

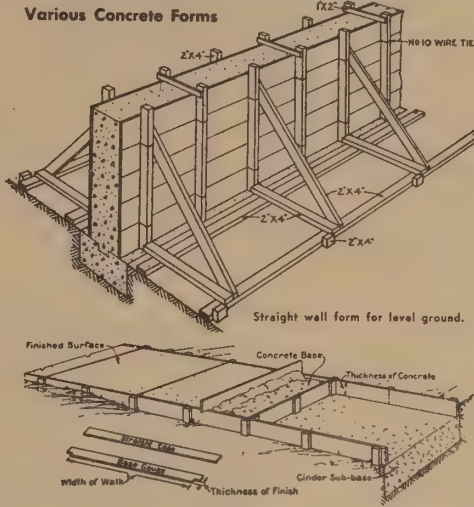

## 4. CEMENT CONTRACTORS' METHODS

A practical method used by cement contractors will give quite accurate results. This rule automatically allows for shrinkage.

Proceed as follows:

- Find cubic feet contents of footings, walls and piers.
- Divide the cubic footage by 15. Result equals tonnage of concrete aggregate (sand and rock combined). Material dealers will furnish concrete aggregate in several proportions, such as 50-50 or 40-60, etc.
- To find sacks of cement multiply tonnage of aggregate by a constant selected from table III.

TABLE III  
AGGREGATE TABLE

Mix	Aggregate Mix	Constant
1-2-3	1-5	4
1-2-4	1-6	3 1/2
1-3-4	1-7	3
1-3-5	1-8	2 1/4

## How-To-Do-It Plumbing and Wiring Books

Most plumbing and wiring books are either too old, or too detailed for use by a novice home builder. However, these two books give you enough basics to be your own plumber or electrician. The plumbing book explains the use of plastic and "no-hub" pipe—both systems avoid the difficult process of melting lead for cast-iron drain pipe connections. The wiring book is a fine introduction to the subject, with sections on service entrances, romex, modernizing old wiring, farm wiring, etc.

**The Practical Handbook of Plumbing and Heating**  
Richard Day  
1969; 130 pp.

**\$4.95** postpaid

from:  
Arco Publishing Company, Inc.  
219 Park Avenue South  
New York, N. Y. 10003

or WHOLE EARTH CATALOG

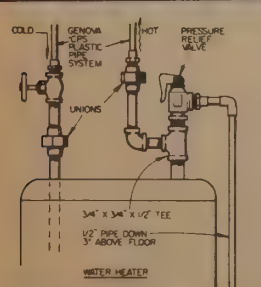

## Wiring Simplified

H. P. Richter  
29th Edition, 1968; 144 pp.

**\$1.00** postpaid

from:  
Park Publishing, Inc.  
P. O. Box 5527 (Lake St. Sta.)  
Minneapolis, Minn. 55408

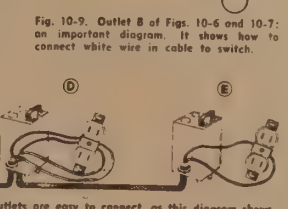
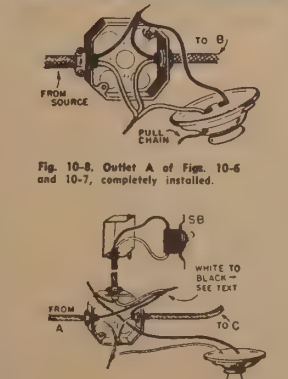
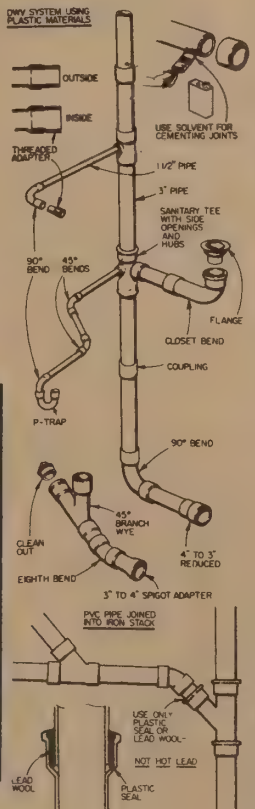
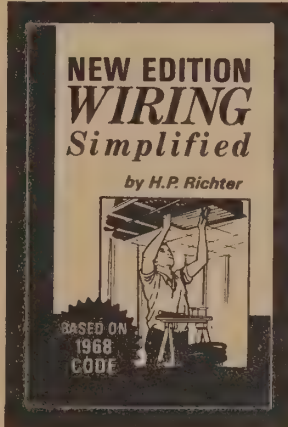

## National Electrical Code 1968

The Code is not law, except as adopted by local ordinances, but its requirements should certainly be met as a minimum in all wiring. Check with your local building department for their code or revisions, and permit information if you want your wiring to be legal. In any case, use the Code as a minimum.

The regulations set up seem to me to be quite reasonable and based mostly on safety. It is somewhat hard to use as a reference because it has a poorly organized index. The index is very complete if you can get into its system.

NFPA says they are coming out with a "One- and Two-Family Residential Occupancy Electrical Code". It will probably be a much more usable book for most people.

Following the Code strictly will produce a safe installation. Producing one that is convenient, efficient, practical, and allows plenty of room for expansion requires planning and study of wiring books such as Sears and Wards electric wiring books (50¢), or Wiring Simplified.

[Suggested and reviewed by  
Fred Richardson]

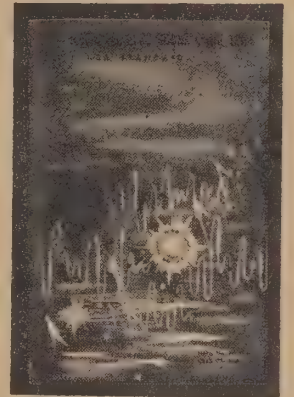

**National Electrical Code 1968**  
1968; 466 pp.

**\$2.00** postpaid

from:  
National Fire Protection Association  
60 Batterymarch Street  
Boston, Mass. 02110

Table 210-25  
Branch Circuit Requirements  
(Type FEP, FEPB, RUW, SA, T, TW, RH, RUH, RHW, RHH, THHN, THW, THWN, and XHHW conductors in raceway or cable.)

CIRCUIT RATING	15 Amp.	20 Amp.	30 Amp.	40 Amp.	50 Amp.
CONDUCTORS: (Min. Size)					
Circuit Wires*	14	12	10	8	6
Taps	14	14	14	12	12
Fixture Wires and Cords	Refer to Section 240-5(a), Exception No. 3				
OVERCURRENT PROTECTION	15 Amp.	20 Amp.	30 Amp.	40 Amp.	50 Amp.
OUTLET DEVICES:					
Lampholders Permitted	Any Type	Any Type	Heavy Duty	Heavy Duty	Heavy Duty
Receptacle Rating	15 Max. Amp.	15 or 20 Amp.	30 Amp.	40 or 50 Amp.	50 Amp.
MAXIMUM LOAD	15 Amp.	20 Amp.	30 Amp.	40 Amp.	50 Amp.
PERMISSIBLE LOAD	Refer to Section 210-24(a)	Refer to Section 210-24(a)	Refer to Section 210-24(b)	Refer to Section 210-24(c)	Refer to Section 210-24(d)

\* These ampacities are for copper conductors where derating is not required. See Tables 310-12 through 310-15.

210-7. Grounding Receptacles. Receptacles and cord connectors equipped with grounding contacts shall have those contacts effectively grounded. The branch circuit or branch circuit raceway shall include or provide a grounding conductor to which the grounding contacts of the receptacle or cord connector shall be connected. The armor of type AC metal-cable, the sheath of MI and ALS cables, or a metallic raceway is acceptable as a grounding conductor.

Exception: For extensions only in existing installations which do not have a grounding conductor in the branch circuit, the grounding conductor of a grounding type receptacle outlet may be grounded to a grounded cold water pipe near the equipment.

## 90-1. Purpose

(a) The purpose of this Code is the practical safeguarding of persons and of buildings and their contents from hazards arising from the use of electricity for light, heat, power, radio, signalling, and for other purposes.

(b) This Code contains basic minimum provisions considered necessary for safety. Compliance therewith and proper maintenance will result in an installation essentially free from hazard, but not necessarily efficient, convenient, or adequate for good service or future expansion of electrical use.

Hazards often occur because of overloading of wiring systems by methods or usage not in conformity with the Code. This occurs because initial wiring did not provide for increases in use of electricity. For this reason it is recommended that the initial installation be adequate and that reasonable provisions for system changes be made as may be required for future increase in the use of electricity.

(c) This Code is not intended as a design specification nor an instruction manual for untrained persons.

It should be noted that farm animals are much less able to withstand shocks, than are human beings. Many cattle have been killed by shocks that would be only uncomfortable to a man.

**Concrete Boatbuilding, Its Technique and its Future**

One of the favourite (and true) tales of ferro-cement enthusiasts is that of the boat with 1/2" thick hull hitting a submerged rock at 12 knots, and smashing the rock. No damage to the hull. This is the long-awaited and best book on ferro cement, by two New Zealand boat builders, and with an introduction by Pier Luigi Nervi, the father of ferro cement.

This rapidly-developing boat building technique, utilizing a mixture of sand and cement plastered over a wire framework results in a super-strong, fireproof 1/2"-3/4" boat hull. The components are cheap, and less skilled labor and special tools are required than in wooden or fiberglass boat building.

The authors share details of their considerable experience here, and there is a fine concise section on how to build, with chapters on reinforcing, mortar mixing, and finish work.

Now that the technique is working well on the sea, it's about time someone tried some free-form ferro cement land structures.



Bending the pipe frames is the first step in building a ferro cement boat, from page 48 of

**CONCRETE BOATBUILDING: Its Technique and Its Future**

by Gairn W. Jackson and W. Morley Sutherland, pioneers in ferro cement boatbuilding in New Zealand. Sutherland, an experienced engineer in concrete, runs Ferro-Cement Ltd. "This is the book we have been waiting for," wrote John Gardner in a review of Concrete Boatbuilding in the April National Fisherman. Well, wait no longer; here she is. Doctor Pier Luigi Nervi, the father of ferro cement, wrote in the Foreword to the book, "This book is without doubt the best guide to concrete boats for all unprejudiced people interested in things of the sea." And the authors say in their introduction, "We have tried in this book to explain in detail the technique of building a ferro cement boat; how the mortar should be mixed, the reinforcing armature constructed, and the concrete plastered. Although care must be taken in building concrete boats, as indeed with any boat, the skills demanded of the amateur are perhaps less than required to build a comparable boat in wood. And on the whole the work is physically easier. The cost of building larger pleasure craft in concrete is certainly less than in any competing material. On this ground alone, the technique promises to have a great impact on future small-boat building." The authors do share the details of their experience in this book. For example, they warn the inexperienced ferro cement boatbuilder that the stringer rods must be wired to the pipe frames very tightly so that they will not slip with the considerable weight of the wet mortar when it is applied. That sounds like the kind of advice that can stop catastrophes. The most important part of this book is the concise section on how to build, covering setting up the reinforcing, mixing the mortar, and plastering and finishing the boat. But the book also describes the development of concrete technology, compares ferro cement with wood, steel, and fiberglass boats, tells how some ferro cement boats have performed, discusses ferro cement applications to fishing boats, and presents the lines and offsets of the Matangi, a 36-foot, sloop-rigged motor sailor that Sutherland built for his own use. Although this book is obviously not the last word on a fast developing boatbuilding technology, as far as we know, it's the best book in print on ferro cement boatbuilding.

from National Fisherman

All of the following prices are postpaid.

- Automobile Guide (AUD-1) \$6.95
- Home Appliance Service Guide (AUD-2) \$6.95
- Radiomans Guide (AUD-3A) \$5
- Television Service Manual (AUD-3B) \$5
- Handy Book of Practical Electricity (AUD-4) \$5.95
- Truck and Tractor Guide (AUD-5) \$5.95
- Plumbers & Steam Fitters Guides - 4 Vols. (AUD-6)
- Painting & Decorating Manual (AUD-7) \$4.95
- Carpenters and Builders Guides - 4 Vols. (AUD-8) set \$16.95
- Diesel Engine Manual (AUD-9) \$6
- Welders Guide (AUD-10) \$4.95
- Mathematics and Calculations for Mechanics (AUD-11) \$4.95
- Mechanics Library (AUD-12) \$13.50 set
- Wiring Diagrams for Light and Power (AUD-13) \$4
- Home Refrigeration & Air Conditioning Guide (AUD-14A) \$6.95
- New Electric Library 10 Vols. (AUD-15A) set \$25
- Answers on Blueprint Reading (AUD-25) \$4.95
- Masons & Builders Guides - 4 Vols. (AUD-26) set \$10.50
- Electric Motor Guide (AUD-27) \$5.95
- Oil Burner Guide (AUD-28) \$3.95
- Sheet Metal Pattern Layouts (AUD-29) \$7.50
- Sheet Metal Workers Handy Book (AUD-30) \$3.95
- Mechanical Drawing Guide (AUD-31) \$3
- Mechanical Drawing and Design (AUD-32) \$3.95
- Questions & Answers for Electricians Exams (AUD-34) \$3.50
- Electrical Power Calculations (AUD-35) \$3.95
- New Electric Science Dictionary (AUD-36) \$3.50

**Additives**

If one wishes to speed up the action of ordinary Portland cement, the addition of a suitable accelerator will help to achieve a higher early strength. The addition of a little true pozzolanic material in place of some of the cement can assist where the aggregate is high in lime content by combining with free lime to produce a better product. In New Zealand professional practice is now to discontinue using pozzolana as the aggregates used are of a high silica content. Rather than lime, which has several disadvantages, we recommend a good proprietary plasticizer. One of the great advantages is that modern plasticizers require no lengthy preparation as does lime. Although most plasticizers have a tendency to reduce strength slightly, they do enable less water to be used and certainly improve workability considerably. They should, however, be used sparingly and in quantities only sufficient to make the mix workable.

Generally speaking, additives such as waterproofing agents should be looked at carefully. It is difficult to improve on high-grade Portland cement as an impervious barrier when mixed with well-graded sand for boat use. In New Zealand so-called waterproofing additives are not used.

Clean and well-graded sand is important if one is to make the high grade impervious mortar required for boatbuilding. Sharp silica sands are preferable, but not essential.



Fig. 10—Shoestring rowboat

- (a) A rough and ready rowboat can be built from beach sand and cement as follows. Although not in the best tradition of ferro-cement, the form of construction is beautifully simple and inexpensive. It could conceivably have a military application.
- (b) First form a mould of damp beach sand. Mix in a little fast-setting cement for the outer layer. Cover with polythene cut and taped where needed.
- (c) Next cover with approximately four layers of 1" chicken netting. Wire tie at overlaps and hold at gunwale with a band of No. 8 fencing wire. Additional bands of fencing wire over the hull add stiffness. Wire mesh to these.
- (d) Finally plaster with beach sand and quick setting cement mixed 2 to 1 with a minimum of water. Plaster layer of approximately 1", thickening to an inch at the gunwale, more at the keel. After two days, lift hull from mould, patch up inside and where possible sink boat to cure concrete for a few days.

Wood attached to low grade concrete can result in a fungus penetration under water, but here again this has not been apparent with high density mortar. An epoxy coat beneath any woodwork could allay any fears.

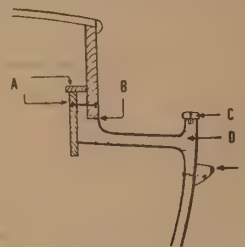

Fig. 25—Detail showing common method of joining a wood cabin to a concrete deck. Recess in concrete is achieved by fastening a guide batten before plastering.

A: Wood caps. B: Cabin wall set into concrete turn up. Sealing compound is used behind joint. C: Wood cap. D: Ferro-cement hull and deck. E: Brass cap on wood rubbing stake.



**Concrete Boatbuilding Its Technique and Its Future**  
Gairn W. Jackson  
W. Morley Sutherland

\$7.95

postpaid

from:  
John de Graff, Inc.  
34 Oak Street  
Tuckahoe, N. Y. 10707

or WHOLE EARTH CATALOG

See p. 37 for more information on Ferro Cement.

There are several different types of concrete mixers in general use. The most common machine used by jobbing handymen is the tilting drum mixer. Although satisfactory for general work, this type is not recommended for mixing mortar for boat construction. One objection is that a stiff mix, such as required for boats, tends to cling to the bottom of the drum and not become adequately mixed. Far better is the revolving paddle type, or the revolving pan and paddle mixer. In both of these the mix tends to be squeezed by the inclined paddles and workability is achieved with less water than would be needed otherwise. The latter consists of an open pan which revolves. Inside the pan, paddles attached to an eccentrically placed shaft revolve either in the same, or opposite direction to the pan. Both are illustrated diagrammatically.

Usually the mixer will be required for only a day at a time, and it is suggested that the average builder might find it more economical to hire, rather than buy, a suitable machine.

In practice it will be found that the mixer bowl and blades will keep cleaner if some of the measured water content is added first, followed by some sand. Then the bag of cement can be broken and its contents added, followed quickly by the remaining sand, water and plasticizer. Pozzolana and any other additives should be dusted as evenly as possible throughout the mix while turning.

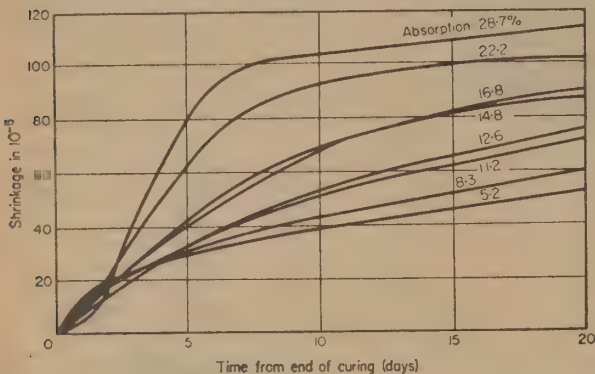

Fig. 18

The quantity of water in a mix has a considerable bearing on the strength of the concrete produced. Simply stated, the rule is this: a low water-cement ratio increases strength, a high water-cement ratio decreases strength. But obviously there must come a point where the water content can be too low. The minimum amount of water necessary to begin the process of hydration may still be too low to make the mix sufficiently workable to enable it to be properly compacted. Insufficiently compacted dry mixes may be weaker than well-compacted wet mixes at a certain point, as the following diagram shows.

**Mix proportions**

Some interesting shrinkage test results (shown below) have been published by J. G. Byrne and W. Wright, to whom we are indebted.

Cement-sand ratio	Shrinkage Tests									
	Neat	0.70	0.60	0.50	0.40	0.40	0.40	0.33	0.33	
Water-cement ratio	0.35	0.40	0.40	0.40	0.45	0.50	0.55	0.50	0.55	
Shrinkage	84	71	63	44	57	57	53	47	45	

Obviously, it would appear that mortar made with a cement-sand ratio of approximately 0.50 (2 of sand to 1 of cement) and a water-cement ratio of 0.40, produces a satisfactory combination from the point of view of shrinkage. Mixes of approximately this type have been used by boatbuilders in many countries, and our experience in New Zealand would indicate that these proportions are basically satisfactory in practice. Dr Nervi has used proportions which are similar.

**Audel Guides**

We've seen no series of individual technique publications more complete than the Audel books published by Howard Sams and Company. However, we're not proficient enough in this area to critique particular manuals against others in their field. Suggestions and reviews invited.

This part of the WHOLE EARTH CATALOG should be one of the most thorough. How-to books are notoriously unreviewed.

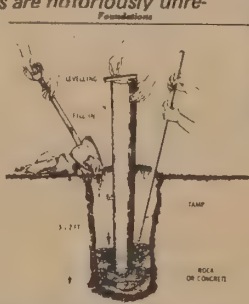

A method of creating a seal from a large rock or concrete at bottom of the hole. The seal is created from an angle with a slant.

from:  
Theo. Audel & Company  
4300 West 62nd Street  
Indianapolis, Indiana 46206

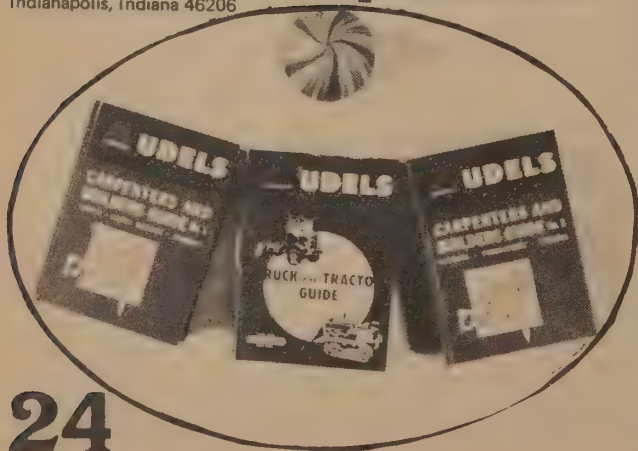

- Power Plant Engineers Guide (AUD-37) \$6.95
- Questions & Answers for Engineers & Firemans Exams (AUD-38) \$4
- Pumps, Hydraulics, Air Compressors (AUD-40) \$6.95
- House Heating Guide (AUD-41) \$5.95
- Milwrights & Mechanics Guide (AUD-42) \$6.95
- Do-It-Yourself Encyclopedia 2 Vols. (AUD-43) \$8.95
- Water Supply & Sewage Disposal Guide (AUD-46) \$4
- Gas Engine Manual (AUD-48) \$4
- Outboard Motor & Boating Guide (AUD-49) \$4
- Encyclopedia of Space Science - 4 Vols. (AUD-50) set \$19.95
- Domestic Compact Auto Repair Manual (AUD-52) \$5.95
- Foreign Auto Repair Manual (AUD-53) \$5
- Programmed Basic Electricity Course (AUD-54) \$4
- Home Workshop & Tool Handy Book (AUD-55) \$5
- Home Modernizing & Repair Guide (AUD-56) \$2.95
- Practical Chemistry for Everyone (AUD-57) \$5.95
- Home Gas Heating and Appliance Manual (AUD-59) \$3.50
- Practical Guide to Mechanics (AUD-61) \$4
- Practical Mathematics for Everyone - 2 Vols. (AUD-66) set \$8.95
- Architects and Builders Guide (AUD-69) \$4
- Handbook of Commercial Sound Installations (AUD-92) \$5.95
- Practical Guide to Tape Recorders (AUD-93) \$4.95
- Practical Guide to Auto Radio Repair (AUD-94) \$4.50
- Practical Guide to Citizens Band Radio (AUD-95) \$4.95
- Practical Electronics Projects for the Beginner (AUD-96) \$4.95
- Practical Guide to Servicing Electric Organs (AUD-97) \$4.95
- Practical Guide to Building Maintenance (AUD-99) \$4.95
- Practical Guide to Fluid Power (AUD-100) \$6.95
- Practical Science Projects in Electricity/Electronics (AUD-102) \$4.95

**★ Plastics in Building**

With all the sealants, plastic pipes, foams and the like coming into prominence in the building industry, it's handy to have a book like this, which describes the properties and characteristics of the many plastic materials now in use.

There is introductory information on reinforced plastic shell structures, adhesives, roofs, coatings, and reports on the use of plastics in other countries.

Both the plastics chemist and the architect are designers of structures. The architect builds with units that the eye can see and the hand can weigh. The chemist's building blocks are tiny molecules, far smaller than one-millionth of an inch, which he strings together to make aggregates called **polymers**. These little chains, barely discernible by electron microscope, are entwined and sometimes tied together to give us the plastics.

**Sprayup (Figure 5-11)**

The sprayup process lends itself particularly well to the manufacture of large structural polyester based panels. In this process, chopped fibers and resin are deposited simultaneously against a mold surface. The unit used for this deposition consists of a chopper and dual spray nozzles. Continuous strand is fed into the chopper where it is cut to length. Fiber length can be varied from about 1/2 to 2 inches. (The longer fibers are desirable for structural panels because they impart higher mechanical properties.) The fibers are fed into the path of the dual spray nozzles. Separate reservoirs supply one nozzle with catalyzed resin and the second nozzle with accelerated resin. The resin formulation is tailored such that neither component is highly reactive, and therefore, each may remain in the reservoirs for at least several hours. When the products leave the dual elements of the spray gun, they intersect and intersperse, and pick up the chopped fibers before striking the mold. The resin mixture is then ready to cure at a convenient rate as predetermined by the concentration of catalyst and accelerator.

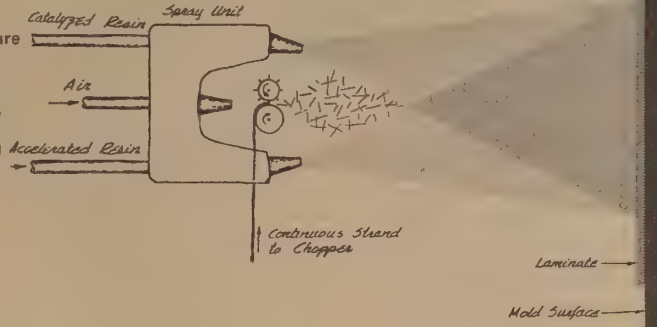

Fig. 5-11. Schematic of sprayup process.

**Plastics in Building**

Irving Skeist, Ed.  
1966; 466 pp.

**\$18.00** postpaid

from:  
Van Nostrand-Reinhold  
450 East 33rd Street  
New York, N. Y. 10001

or **WHOLE EARTH CATALOG**

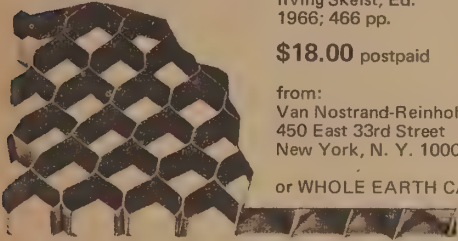

Fig. 8B-2. Sandwich panel with honeycomb core.

**★ Sweet's Files**

It's a shame some of the best tools are the hardest to get to. Though Sweet's are free, they are given only to Public Libraries in cities of more than 250,000 people and to the 10,000 most active architectural firms in the U. S. It's often possible to talk a local architect out of last year's edition if you speak for it early. They do not become obsolete just because they are a year or two old.

Sweet's is essentially a catalog of catalogs, a filing system in a yard of volumes which binds, lists and cross-references catalogs of manufacturers. It covers six areas that I know of: Industrial, Residential and Commercial Construction and Product, Interior and Plant Design. Each file in these areas is a separate entity. The commercial construction file is the one most architects have and for any one building, it is the most useful. It is very helpful when improvising details for it provides a full spectrum of what is already available for the ready made answers to most problems. Manufacturers usually do a pretty good job with the material they include in the files so there's not much left to question as to how their product works. If there is any question, the manufacturer's representative is usually listed, with his phone number and address. He'll usually bend over backwards to help you if you say you saw it in Sweet's.

[Suggested and reviewed by ONYX]

**Sweet's Files**  
Sweet's Construction Division  
McGraw-Hill Information Systems Company  
330 West 42nd Street  
New York, N. Y. 10036

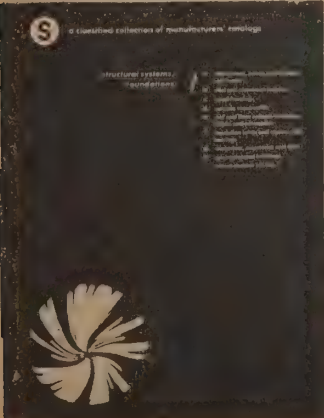

**Village Technology**

VITA (Volunteers for International Technical Assistance) is the only source of specific practical information on small-group technology that we've found. But what a source. They have prepared a two-volume "Village Technology Handbook" for overseas use by the U.S. Agency for International Development that is ideal for rural intentional communities. This handbook now is in revision; the new edition should be available as of January, 1970—inquire for price.

Also VITA has a catalog of funky tools—Village Technology Center Catalog—available free. For the items listed they will supply plans for making the tools, or rent or sell the items—inquire for price.

VITA has a series of specific papers that cost very little (e.g. 30¢). Titles include "Low Cost Development of Small Water-Power Sites," "How to Salt Fish," "Making Building Blocks with CINVA-Ram," "Solar Cooker Construction Manual."

from:  
VITA  
College Campus  
Schenectady, N. Y. 12308

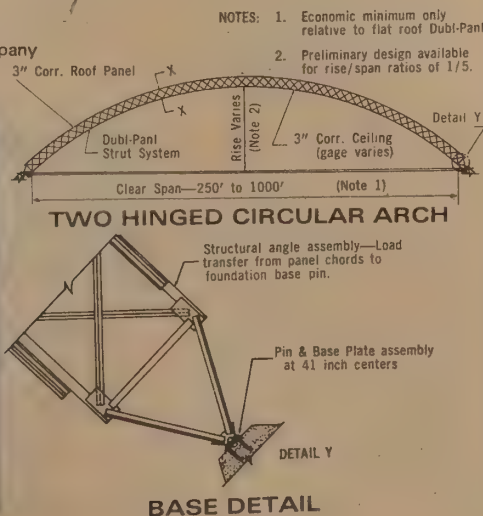

**JOINT SHAPES**

The shape of the joint has considerable effect on the success of the joint sealant. As a joint moves, stresses are imposed on the sealant that may be more or less severe, depending on the natural or original shape of the joint. The deeper a sealant is in a given joint for a given width, the more "necking" and internal stress occurs in the sealant as the joint opens. As is seen in Figure 10-4, a joint 1/2 inch wide X 1 inch deep "necks" or pulls up within itself far more than a joint 1/2 inch wide X 1/2 inch deep. Consequently, there is a greater chance for cohesive failure with the deeper joint. A similar problem is solved when a sealant is used in a joint in which there is no breaker strip at the bottom or back of the joint, so that the sealant is in contact with three sides of the joint with only the face of the joint exposed. This, again, puts a greater strain on the cohesive strength of the sealant. The obvious recommendation here is to employ a breaker strip or type of backing which will not restrict or restrain the sealant, but will move with it as the joint moves (Figure 10-5).

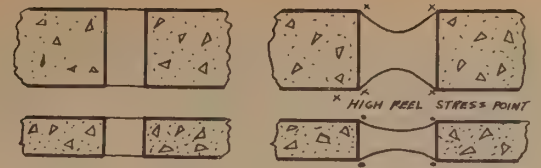

Shrinkage is another characteristic whose importance varies with the use of the sealant. If the sealant is applied in a corner joint as a fillet, shrinkage actually may be desirable in order to have the joint become concave. On the other hand, a sealant put in the 1/4-inch joint between two adjacent porcelain enamel panels cannot have excessive shrinkage or it will shrink into the joint providing an unsatisfactory appearance and also reducing the amount of sealant in the joint, possibly to an unsatisfactory amount. Sealants are available with shrinkage rates ranging from practically 0 to 50 per cent. If a very low order of shrinkage is required, a two-part chemically curing compound will provide shrinkages in the order of 0 to 2 per cent. If a modest amount of shrinkage is permissible and other characteristics unique in the compound are desired, solvent-release type compounds are available with shrinkages ranging from 10 to 20 per cent. For certain applications, sealants with 40 to 50 per cent solven, providing about that amount of shrinkage eventually, may be entirely satisfactory, e.g., for needle glazing and other small joints where a concave finished joint is not harmful.

Several plastic coatings, including epoxies, urethanes and polyesters, have established themselves as extremely durable surfaces with excellent bonding characteristics. These coatings form their films by chemical action rather than oxidation or evaporation as in the case of the paints. A urethane coating was used for the car shelter and breezeway panels of the South Bend house. This two-part system promises excellent weather resistance and color retention. One clear coat of the formulation was plant applied during fabrication of the sandwich panels. After the initial color coat was mixed and brush applied at the site, an additional coat which contained a pure silica sand for texturing finished the surfaces. The coating has performed well and appears to be particularly able to conceal plywood grain raising and checking.



Fig. 19A-3. Extruded vinyl waterstop. (Courtesy, Cement & Concrete Technology)

A remarkably designed extruded vinyl (Figure 19A-3) waterstop is being used as a peripheral insulation. The diamond-shaped center portion serves as a mechanical spring. When the concrete expands, the diamond collapses; when the concrete contracts, the diamond expands pushing the fins tightly into position.

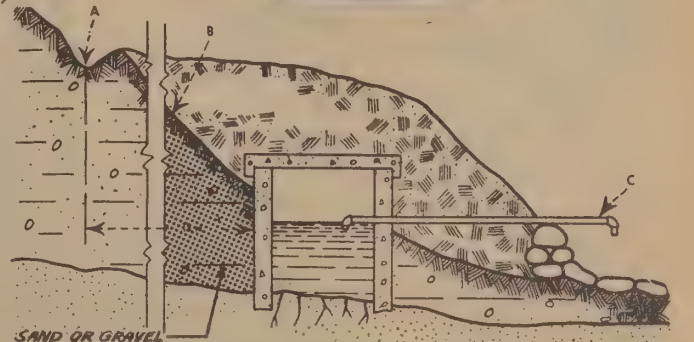

The VITA SOLAR COOKER is designed to be sturdy, relatively easy to make, easy to repair and low in cost. It uses the principle of the Fresnel reflector which concentrates light and heat. The COOKER—when used in areas having more than 2000 hours of sunshine per year—provides the heat equivalent of 500 watts (which will boil a quart of water in 12 to 15 minutes).

Larger models of the COOKER can be provided.

Size: 52" x 46" x 50"  
Wt. 24 lbs.





# The Indian Tipi

Tipis are cheap and portable. To live in one involves intimate familiarity with fire, earth, sky, and roundness. The canvas is a shadow-play of branches by day, people by night. Depending on your body's attitude about weather, a tipi as dwelling is either a delight or a nuisance. Whichever, you can appreciate the elegant design, of a tipi and the completeness of the culture that produced it.

The Laubin's book is the only one on tipis, but it is very good. All the information you need, technical or traditional, is here, and the Laubins are interesting people.

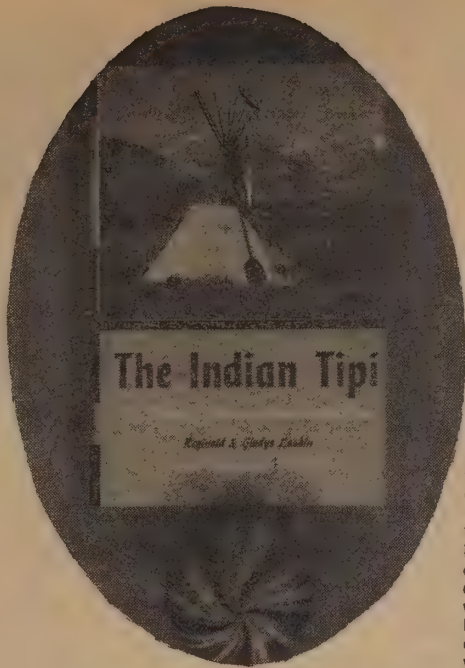

Later we discovered that the idea of a ventilating pipe underground to the fireplace is the very best way of insuring a clear lodge and the most heat.

It is a joy to be alive on days like this, and when we come back to the tipi, after a long ride or a hike in the mountains, the little fire is more cozy and cheerful than ever. The moon rides high in the late fall nights, and when it is full, shines right down through the smoke hole. Its pale white light on the tipi furnishings, added to the rosy glow of the dying fire, is beautiful beyond description.

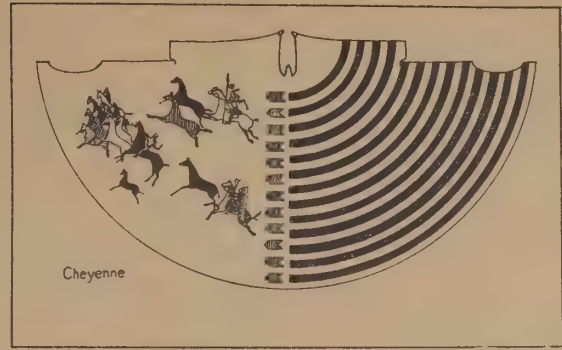

Indians had definite rules of etiquette for life in the tipi. If the door was open, friends usually walked right in. If the door was closed, they called out or rattled the door covering and awaited an invitation to enter. A shy person might just cough to let those inside know he was waiting. If two sticks were crossed over the door, it meant that the owners either were away or desired no company. If they went away, they first closed the smoke flaps by lapping or crossing them over the smoke hole. The door cover was tied down securely and two sticks were crossed over it. The door was thus "locked," and as safe in Indian society as the most strongly bolted door would be in our civilization today.

The Indian way of attaching peg loops, as illustrated, is not only ingenious but easy and sturdy—far better than either sewn or stamped grommets. Insert a pebble about 1/4 of an inch in size on the under side of the cover about six inches above the edge, at a seam wherever possible, and around this pebble tie a piece of 3/16-inch cord. Double the cord, tie it in either a square knot or a clove hitch about the pebble, then join the free ends in a square knot. Marbles will do if you cannot find smooth round pebbles.

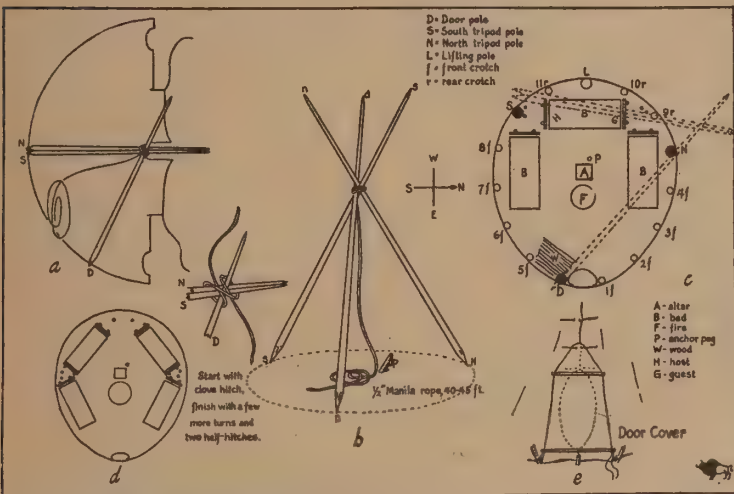

FIG. 3. Erecting the Sioux Tipi.

**The Indian Tipi**  
Reginald and Gladys Laubin  
1957; 208 pp.

**\$4.95** postpaid

from:  
University of Oklahoma Press  
Sales Office  
Faculty Exchange  
Norman, Okla. 73069

or **WHOLE EARTH CATALOG**

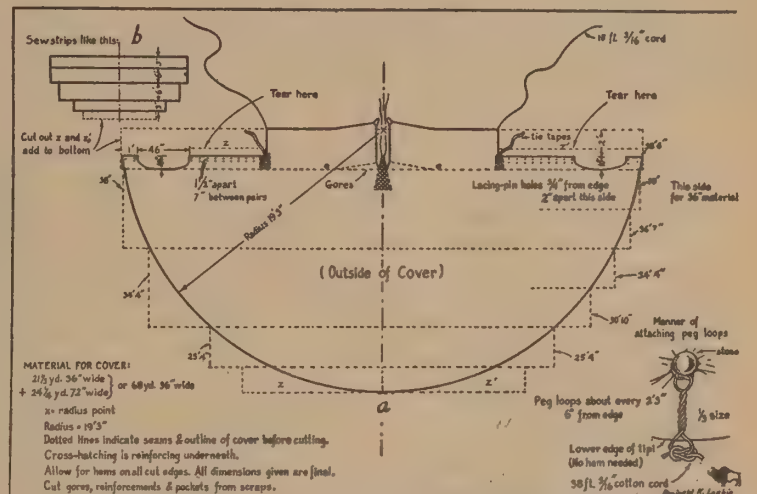

FIG. 1. Pattern for Sioux Tipi (18-foot).

## Tipis

We have word about three sources in the U.S. of ready-made tipis, and so far Goodwin-Cole is still the best—best construction, lowest cost. They also have tipi liners, which you will need if weather is wet or cold.

For the following, shipping weights are undetermined. Inquire, or have the item sent shipping cost C.O.D.

10-foot is suitable for nomadic couple; 14-foot for small family. 20-foot for extended family or occasions. Flame-treated is unpleasant; law requires it in some places. Tipis of green, blue, orange, red or yellow drill are available. Poles are available if you're that lazy.

from:  
Goodwin-Cole Company  
1315 Alhambra Blvd.  
Sacramento, California 95816 or **WHOLE EARTH CATALOG**

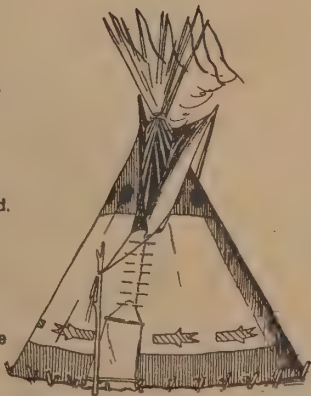

TIPI SIZE	FLAME RESISTENT CALIFORNIA CODE				WOOD POLES 14/SET UNPRINTED	PAINTED DESIGNS AROUND BASE	TIPI LINER 5' HIGH 10 OZ. S.F.
	10 OZ. S.F. DUCK NATURAL	12 OZ. S.F. DUCK NATURAL	6 1/2 OZ. DRILL BLUE-DRAB. RED-YELLO.	10 OZ. ARMY DUCK WHITE			
10'	\$60	\$64	\$85	\$90	\$40	10 @ \$25	\$28
12'	\$69	\$73	\$94	\$112	\$45	12 @ \$27	\$31
14'	\$77	\$84	\$113	\$129	\$50	14 @ \$29	\$35
16'	\$88	\$94	\$133	\$155	\$53	16 @ \$31	\$38
18'	\$97	\$107	\$150	\$172	\$57	18 @ \$33	\$42
20'	\$107	\$119	\$174	\$202	\$60	20 @ \$35	\$45
22'	\$117	\$134	\$197	\$236	\$63	22 @ \$37	\$52
24'	\$137	\$154	\$233	\$285	\$68	24 @ \$39	\$62

Door Cover . . . \$8.50  
Two Designs . . . add \$10  
8' Front Pole . . . \$3  
40' of 1/2" Rope . . . \$4  
**TERMS OF SALE**  
Prices subject to change without notice. Prices are F.O.B. our Sacramento plant. All orders subject to acceptance by Home Office, Sacramento. New customers are asked to send check with order. One-half deposit required on C.O.D. orders.

## Aladdin Kerosene Lamps

Coleman lamps are terrible — they hiss and clank and blind you, just like civilization.

Aladdin is the answer if you need good light and 117ac isn't around. It is bright, silent, and requires no pumping. (It does require some babying to keep the mantle from smoking up; it's like not burning toast.)

British made and efficiently designed, the lamps are available in this country from:

Aladdin Industries, Inc.  
Kerosene Lamp Division  
Nashville, Tennessee 37210

or **WHOLE EARTH CATALOG**  
Some of the Aladdins are rather ornamental. The simplest designs are B-165 Font Lamp (aluminum) and B-223 Hanging Lamp  
**\$22.95** shipping wt 2.5 lbs  
**\$28.95** shipping wt 3.5 lbs shade extra

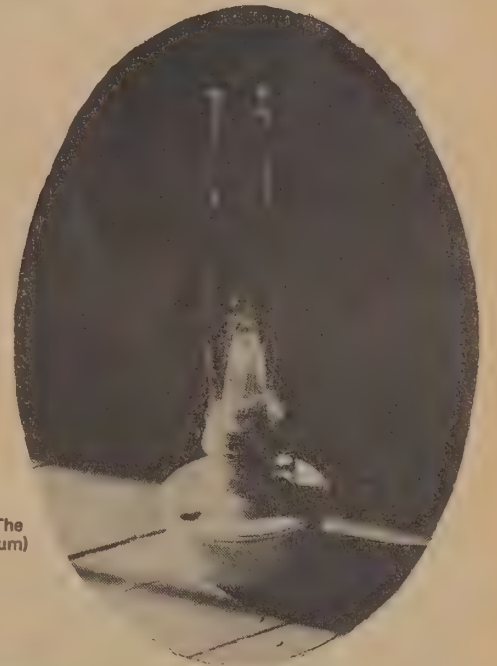

N-6400 Shade **\$3.95**  
N-103 Chimney **\$2.40**  
N-150 Mantle **\$.98**

## Man's Role in Changing the Face of the Earth

This book of almost 1200 pages is the result of a major conference held in 1955, sponsored by the Wenner Gren Foundation for Anthropological Research. More than 50 scholars submitted papers, covering almost every imaginable point of view related to man's capacity to transform his physical environment. Though first presented nearly 15 years ago, the facts and insights are richly rewarding today. In my opinion in fact, it is an unsurpassed achievement in assembling pertinent, insightful information of interest not only to serious students of the planet Earth, but to non-trained readers as well.

The three sections of the book are: I. "Retrospect", an historical background; II. "Process", methods and agencies involved in man's interactions with the land; and III. "Prospect", the effects and future implications of man's habitation of the Earth. Some typical subjects covered within these sections include: fire as the great force employed by man; origins and decline of woodlands; man and grass (sic); ecology of peasant life; harvests of the seas; ports channels and coastlines; and sewerage (don't belittle sewerage—society is structured around it).

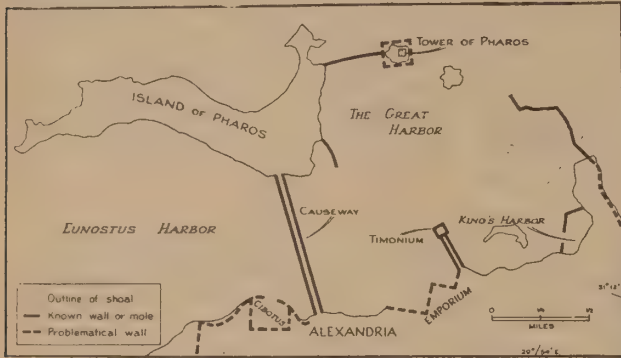

FIG. 106.—Harbor at Alexandria, Egypt, about the beginning of the Christian Era.

This book rewards a reader like me because of its minimum of moralizing and its abundant substance. Edgar Anderson, director of the Missouri Botanical Garden in St. Louis and without whom such a book as this would be certainly incomplete, pointed out that the average thoughtful person has little inkling of how man has reclothed the world. Even professional biologists have been tardy in recognizing that a significant portion of the plants and animals surrounding us are of our own making. For example, neither Kentucky bluegrass nor Canada bluegrass is native to those places, but came from Europe. The corn belt is a very obviously man-dominated landscape, but the casual observer might never realize that even the grass covered and oak-dotted stretches of what looks like indigenous California vegetation came uninvited from the Old World along with the Spaniards.

[Reviewed by Richard Raymond]

### Two Mushroom Books

Finding a strange, slimy, luminous colored growth on dark rotting wood is surprise and pleasure; to extend that experience into identifying it and possibly EATING it is even better. For the beginner one batch of mushrooms can occupy a whole day, from finding them, through waiting for a good spore deposit and making a decision, to cooking them. An efficient guidebook is essential to avoid frustrations.



**The Savory Wild Mushroom**  
Margaret McKenny  
1962; 133 pp.

\$3.95 postpaid

from:  
University of Washington Press  
Seattle, Washington 98105  
OR  
WHOLE EARTH CATALOG

On a tramp through the fields and forests, carry with you a small jar of butter, creamed with salt and pepper. On finding any edible mushroom (except morels or elfinsaddles), collect a few dry sticks and fire them. Split a green stick (alder or willow) at one end. Put the mushroom in the cleft, hold it over the fire until tender, season with the butter. Eat from the stick.

from "The Savory Wild Mushroom"

Generally speaking, the plants which follow man around the world might be said to do so, not because they relish what man has done to the environment, but because they can stand it and most other plants cannot.

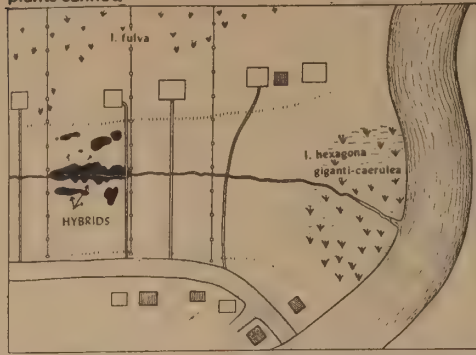
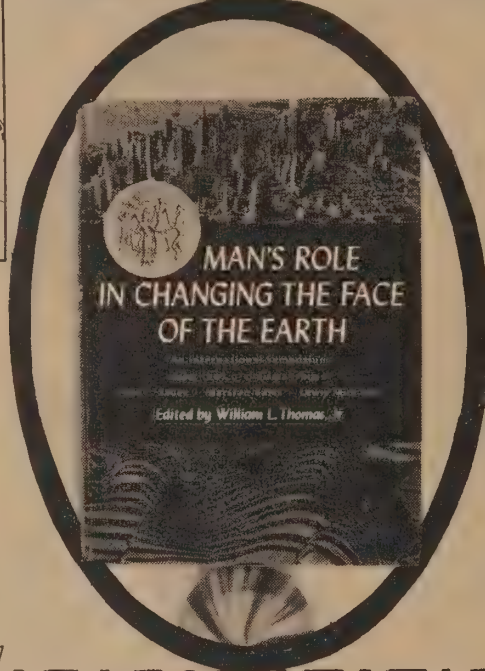

FIG. 133.—A demonstration of man's unconscious role in creating new plants. (From Riley, 1938.) At the far right one of the minor bayous of the lower Mississippi Delta. At right angles to it and running nearly across the figure is the abandoned channel of a former stream, now drained by a ditch. The natural levees of the stream are slightly higher than the surrounding country. Their sharp inner edges are indicated on the map by hachures. The road has been run along the lower levee, and houses have been built along the opposite one. The property lines (as in many old French settlements) produce a series of long narrow farms, which for our purposes serve as so many experimental plots. Each farm has its house on a low ridge with a long entrance drive connecting it across a swale to the public road on the opposite ridge. The farms (including a score of others which are out of sight to the left of the figure) were originally essentially similar. At the point where the ditch joins the bayou is a large population of *Iris hexagona gigantea-caerulea*. Behind the levee on which the houses were built, *I. fulva* grows on the lower ground as well as farther upstream along the ditch. The key fact to be noted is that the hybrids are on only one farm, that they are abundant there, and that they go up to the very borders of the property on either side. Nature is evidently capable of spawning such hybrids throughout this area, but not until one farmer unconsciously created the new and more or less open habitat in which they could survive did any appear in this part of the delta. (See Anderson, 1949, pp. 1-11, 94-98, for a more complete discussion.)



**Man's Role in Changing the Face of the Earth**  
William L. Thomas, ed.  
1956; 1193 pp.

\$15.00 postpaid

from:  
University of Chicago Press  
11030 South Langley Ave.  
Chicago, Illinois 60628  
OR  
WHOLE EARTH CATALOG

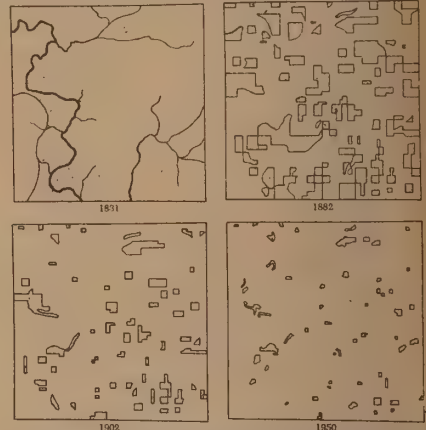

FIG. 147.—Changes in wooded areas of Cedar Township, Green County, Wisconsin (89°54' W., 43°30' N.), during the period of European settlement. The township is six miles on a side and is drained by the Pecos River. The shaded areas represent the land remaining in, or reverting to, forest in 1850, 1902, and 1950.

The McKenny book is compact, but not especially well organized for use. It contains clear and concise descriptions of 83 varieties of fungi, some of them peculiar to the Puget Sound region, the rest common throughout the U.S., and 33 black-and-white and 48 color photographs. There is also an article on mushroom poisons and the many fine recipes make one want to rush to the woods and immediately gather baskets of Chanterelles, Morels and Ceps. Not so easy!

Smith's book, which I prefer, is more technical in language and scope, although, as a field guide, it avoids identification methods involving microscopes and chemicals. It is much more complete, covering 188 varieties with a black-and-white photo of each plus 84 color photos, and it is organized in keys which are super to use if you like being methodical. It is not necessarily true, however, that it is quicker to follow the system: in thumbing through either book, as in wandering in the woods, luck and perseverance further.

[Suggested and reviewed by Sandra Tcherepnin]

### The Mushroom Hunter's Field Guide

Alexander H. Smith  
1958; 1967; 264 pp.

\$8.95 postpaid

from:  
University of Michigan Press  
615 East University  
Ann Arbor, Michigan 48106  
OR  
WHOLE EARTH CATALOG

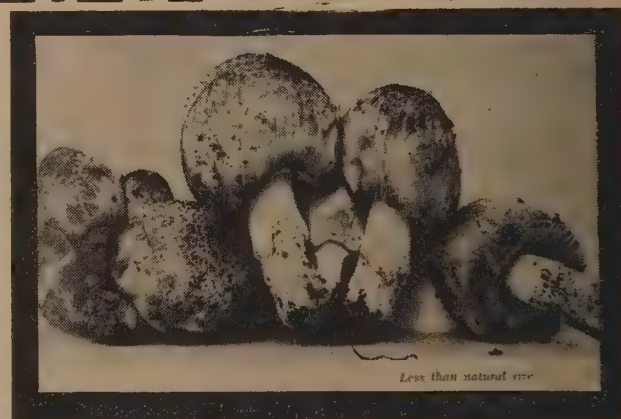
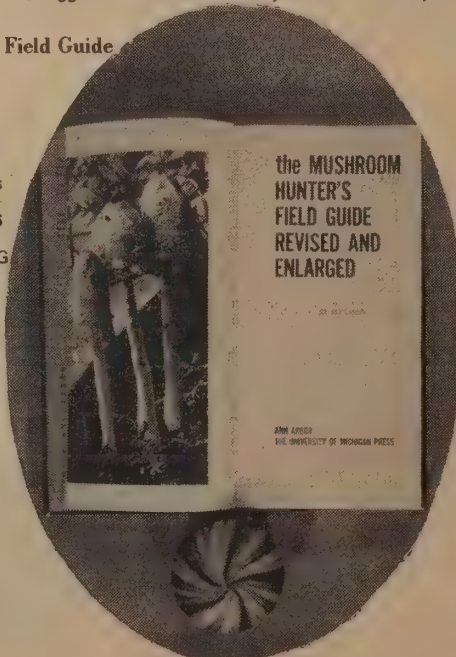

164. COPRINUS ATRAMENTARIUS (Inky Cap)

Edibility. Edible, but some people experience a peculiar type of intoxication from eating this species and afterward drinking an alcoholic beverage. I have now discovered three people in Michigan with this type of sensitivity.

from "The Mushroom Hunter's Field Guide"

### KEYS TO FAMILIES

1. Gills turning black and "melting" at maturity ..... *Coprinus*, in the family *Coprinaceae*
1. Gills not liquefying at maturity ..... 2
2. Gills free from the stalk ..... 3
2. Gills attached to the stalk ..... 6
3. Spore deposit chocolate brown to blackish and mature gills the same color; ring present on stalk ..... *The Agaricaceae*
3. Spore deposit and mature gills paler ..... 4
4. Spore deposit pink to vinaceous or reddish; mature gills about the same color ..... *The Volvariaceae (Pluteus magnus)*
4. Spore deposit white (greenish in one) ..... 5
5. Volva present around base of stalk or remains of outer veil present on the cap ..... *The Amanitaceae*
5. Volva absent; inner veil present; cap if scaly with the scales ingrown and usually of appressed hairs (fibrillose) ..... *Chlorophyllum* and *Leucoagaricus*
6. Spore deposit white to pale lilac, yellow, or pinkish buff ..... 7

from "The Mushroom Hunter's Field Guide"

**Dome Cookbook**

A new art form is evolving in the southwest desert. Multi-colored cartop domes, put together with whatever's lying around. Free heat from the sun. Behind much of the innovating stands Steve Baer, a young inventor who generates enough energy to get others moving too.

This tabloid contains the crystallographic theory and junkyard practice behind Baer's domes: from how to distort a polyhedron without affecting connector angles to how to chop the top out of a car without losing your foot. From all we can determine, Baer's theory is unique in architecture. So is his practice; instead of dying of dissertation dry rot, his notions stand around in the world bugging the citizens.

The Dome Cookbook now in its second printing, is published by Lama Foundation, an experimental community in New Mexico.



When you are putting up a dome panel by panel you often have to use poles to support the wobbly sides as they close in toward the center. When we were putting up the second to last panel in the shop dome we had three poles in strategic spots to hold the wobbly overhanging panels from collapsing. The poles were nailed at the top so they wouldn't fall away if during a moment's strain the load were lifted up and off of them. The panel was an 8' by 19' and extremely heavy. We put it up with an inadequate crew, two men and two women. We struggled for an entire afternoon the last few inches Albert Maher pushed from on top of a spool resting on top of the cab of his pickup which we had driven into the dome. It was touch and go, a clamp might slip, Albert might collapse, the poles might buckle. Each one of many failures seemed equally as probable as getting the monster joined to the neighboring panels. A huge shove, some quick work with the crow bar and clamps—Albert eased off and it still held, I took a few more turns on one clamp and added another one—it was a sure thing, we had it in place!

It felt as if the panel had been lifted into place by some incredible wave we had created that now washed back as we put down tools and Albert got down off the cab. But there was one last thing to check—the poles, were they dangerously bowed under this new load. The entire sensation in my head began for a moment to turn inside out when Holly yelled "look at them" but then I saw what it was—the dome was finding its shape, it had lifted all three heavy poles off the floor, they were hanging from where they had been toe nailed at their tops, swaying slowly. Three important pillars transformed in one moment into three dangling slow swinging pendulums.

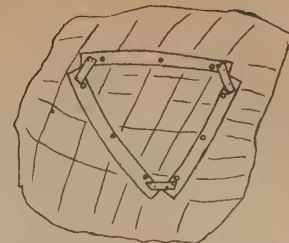

flexible plywood pattern on car top

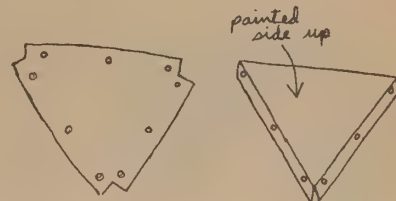

panel, cut and drilled

panel, cut, drilled and broken

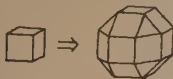

this is a cube and an exploded cube. You can see that rectangles appear over the edges and triangles over the corners.

Regular Dodecahedron exploded in edge length



Here is an exploded cube inside a large cube showing that exploding a small figure or cutting away the edges and corners of a large figure can produce the same thing.



**Dome Cookbook**  
Steve Baer  
1968; 40 pp.

**\$1.00** postpaid from:  
Lama/Cookbook Fund  
P. O. Box 422  
Corrales, N. M. 87048

or **WHOLE EARTH CATALOG**

**Architectural Design**

This is the only architectural magazine we've seen that consistently carries substantial new information, as distinct from the stylistic eyewash characteristic of most architecture journals.

After a year of watching and using AD, it's clear that this is much more than an architectural magazine. It prints lots of news of American creative doings months before any U. S. publication. Its coverage of developments in cybernetics, structure systems, philosophy, use trends (e.g., communes), etc. is extraordinary.

**Architectural Design**  
**\$13.50** postpaid for one year (monthly)

from:  
Architectural Design  
26 Bloomsbury Way  
London W.C. 1

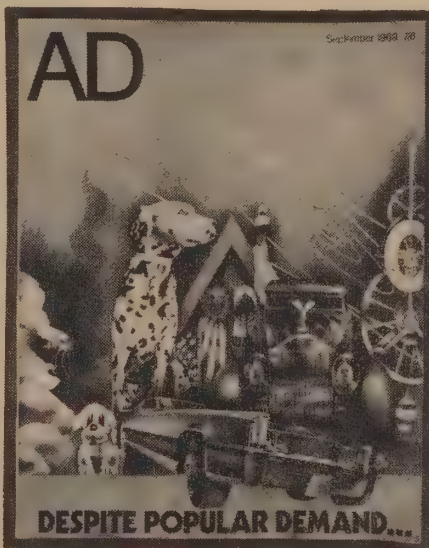

**This Graded Universe—Lancelot Law Whyte**

You should have seen the look on his face when God solved the problem of making an endlessly varied universe. He had already made two. The first was an ideal gas near to maximum dynamical disorder. That was dull; any differences he put into it soon vanished. It was an entropy victory, without order, form, or life.

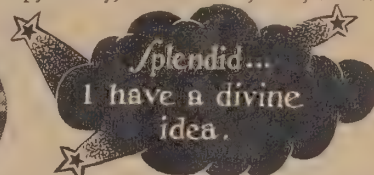

His second was a world of perfect crystals. That was fun; there were 230 different types, all aesthetically intriguing. But each crystal was homogeneous, and therefore rather inert. It was a cold world (near zero), and left him dissatisfied. What he wanted was a blend of order and diversity, enough order to be pleasing and enough diversity to be continually forming new patterns, its fertility born of differences. Then he thought "Splendid. I have a divine idea. My next universe will be the scene of two competing tendencies; morphic<sup>3</sup> processes generating three-dimensional geometrical order, and entropic processes leading towards dynamical disorder. That will make for unending variety, and when they're fluctuating nearly in balance something extraordinary will occur. The morphic processes will keep building ordered units and forming a great hierarchy of structural levels, from parts to wholes, while the entropy processes will tend to disperse the hierarchy. This subtle fluctuating balance will be called "life" by systems that display that vitality in a special mode to be called by them "thinking".



Guadi's Parque Guell—"one of the most cybernetic structures in existence."

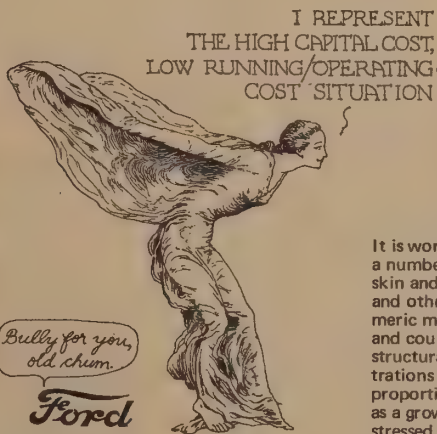

Peter Brookes/Dad

It is worth noting that the piezoelectric effect has been observed in a number of organic materials, among them wood, bone, tendon and skin and the argument has been put forward by Shamos and Lavine and others that the piezoelectric properties of these fibrous polymeric materials function as stress-sensing devices in living organisms and could account for the evolutionary and self-organizing structural characteristics of living things. In wood, stress concentrations due to wind loads would produce an electric potential proportional to the stress in any part of the tree, which might act as a growth signal, causing greatest growth in the parts that are stressed most.

As a combined sensor/effector device the possibilities are even more exciting. The most obvious and immediately valuable—if vaguely banal—proposition is that of producing a compression structure with infinite stiffness.

**Archigram**

Archigram is a free-form magazine published about twice a year by a group of architects, cyberneticians, audio-visual programmers, etc. from Britain and America. Because production is irregular, there is no subscription list; rather, a mailing list to which all new issues are sent with the understanding that you will remit by return.

[Suggested by ONYX]

**Archigram**  
Editor: Peter Cook

**\$1.00** postpaid

from (to get on mailing list)  
Archigram Group  
School of Architecture  
U.C.L.A.  
Los Angeles, CA 90024  
or  
59 Aberdare Gardens  
London N.W.6, England

**Architectural Graphic Standards**

If Sweet's is a kind of magic lamp in many architects' and builders' libraries, the genie might well be 'Graphic Standards. This volume has been around for years; its latest edition is its fifth. Whenever the office expert hasn't got the answer, 'Graphic Standards usually does. It is the how-do-do-it book of construction. It doesn't cover domes but if there's anything else you have in mind, it's probably in there. Older construction techniques (stone masonry, etc.) are covered as well as relatively newer techniques; it's very useful in remodeling and repair work. Everything is done with a minimum of verbiage and a maximum of illustrations and very useable charts and graphs. 'Graphic Standards is so taken for granted by any architecture student or office that it's almost become a challenge to stay away from it; ultimately, however, there's seldom a building built without reference to it in the U. S. today. TOOL.

[Suggested and reviewed by ONYX]

**Architectural Graphic Standards for Architects, Engineers, Decorators, Builders, Draftsmen and Students**

Charles G. Ramsey and Harold R. Sleeper  
1932... 1956; 757 pp.

**\$18.00** postpaid

from:  
John Wiley and Sons  
Publishing Co.  
1 Wiley Drive  
Somerset, N. J. 08873

Western Distribution:  
1530 South Redwood Rd.  
Salt Lake City, Utah 84104

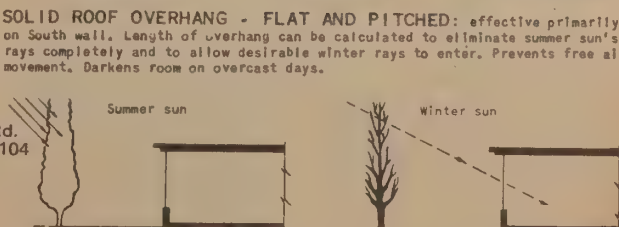
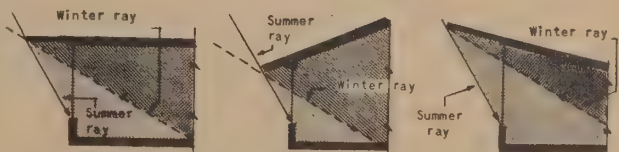

DECIDUOUS TREES (adjacent to South wall): eliminate or diffuse sun's rays in summer, allow sun penetration through bare branches in winter.

★ Environment

There's growing horror that we may have reached the "point of no return" in planetary pollution. This is a monthly magazine with factual reports of current ecological trends. Much information on insecticides, oil and nuclear contamination, and good reviews of books on the environmental sciences. "Who will care how many battles with Nature man wins if Nature wins the war?"

[Suggested by Barry Kast]



Many more nuclear explosions may be set off in Texas, Utah, Wyoming, Oklahoma, Kansas, Montana, New Mexico and the Dakotas. A report published by the U. S. Bureau of Mines calls these areas "amenable to stimulation (for extracting petroleum and natural gas) using nuclear explosives." David Evans of the Colorado School of Mines predicts that this could mean as many as ten thousand underground nuclear explosions.

Defoliation of the United States-Canada border is continuing, with helicopters spraying Tordon. The program is being conducted by the International Joint Commission of the U. S. and Canada, which informs Environment that the entire 3,000-mile border—except for cities and waterways—is included. The swath of trees and brush being sprayed is from 50 to more than 100 feet wide. Tordon is a persistent herbicide, not licensed for use on crops. Repeated spraying of the border to keep it barren will result in a dead strip of eroded, impoverished soil. Drift of the herbicide will damage plants on either side of the strip. Long-range ecological effects of this break of unprecedented length in the natural continuity of plant and animal life are difficult to predict. No statement from either government on the reason for the defoliation has been made as far as we have been able to discover.

Mrs. Winter says, "The bread you put in your mouth daily is literally embalmed to keep it feeling soft and fresh long after it isn't..."

Environment  
\$8.50 /yr. (monthly)

from:  
Committee for Environment Information  
438 North Skinker Boulevard  
Saint Louis, MO 63130

★ Oceans Magazine

"Wow, what a great magazine, and why hasn't anyone done something like this before..." It's an old line, but with Oceans, it applies. The articles are varied and well written, the photography is beautiful, and most important it's informative. Amateur oceanographers, as well as professionals, couldn't help but profit from an occasional issue.

[Reviewed by Mary McCabe.  
Suggested by John Holt]



Homo sapiens holds a precarious perch at the top of what biologists call "the food pyramid"—simply stated, higher organisms feed on lesser organisms. The minute creatures that inhabit the oceans furnish food at the bottom of the pyramid. From that base, the pyramid works its way up to the more familiar vertebrates such as fish, birds and then mammals, where Man sits at the apex. What Man is now doing is to undermine the pyramid and to undermine it to the point of toppling the entire structure.

One of the most immediate causes is indiscriminate use of pesticides, DDT being the prime offender. Not only does DDT have an immediate effect when directly applied, it is a practically inert chemical; it does not break down but retains its potency for a very long time. After its use on crops, the lethal compound washes into streams and eventually out to sea where the minute organisms at the base of the pyramid assimilate it. As you can readily see, since the pyramid works up, the dosage becomes more concentrated at each higher stage until it takes its toll, as in the case of the brown pelican, whose reproductive cycle has come to almost a complete standstill.

Today the oil industry has an investment of \$15 billion in offshore drilling, and it is most probable that this will at least double in the next ten years. Offshore drilling activities have been growing by 18 to 20 percent annually with no end in sight. You might ask, "Why so much emphasis on offshore drilling?" The answer is clear. Of the known good onshore sites, 90 percent have already been drilled leaving oilmen only one last great frontier—the sea. Less than 10 percent of the prospective drilling sites in the ocean have ever been explored.

★ Water in the Service of Man

"Water, that's our life," a Navaho told me once. This book details how the man-water relationship is played—ancient techniques, theory, flow in pipes and channels, waves, pumps, turbines, wells hydrology. A neat package.

[Suggested by Steve Baer]

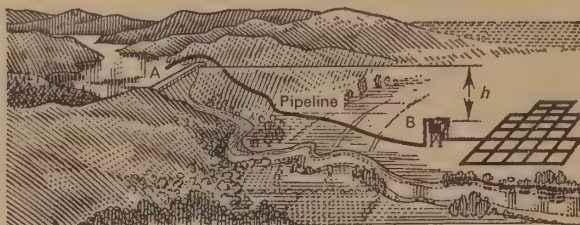

FIGURE 39. Water-supply pipeline. Practically all of the difference,  $h$ , in level between A and B represents energy expended by the water in overcoming pipe-flow resistance.

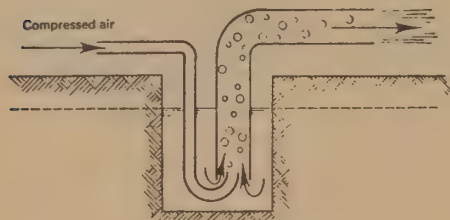

FIGURE 65. Air lift pump.

Water in the Service of Man  
H. R. Valentine  
1967; 221 pp.

\$1.45 postpaid

from:  
Penguin Books  
3300 Clipper Mill Road  
Baltimore, Md. 21211

or WHOLE EARTH CATALOG

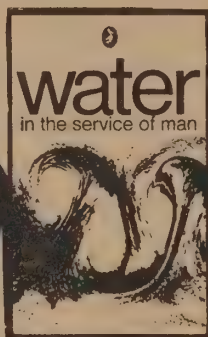

★ Oceanography in Print

A Whole Oceans Catalog! This pamphlet is certainly of use to anyone wanting to learn about the sea. It gives access to information ranging from "elementary" to "adult technical" interests. The preface makes a claim about the ease of obtaining most of the books listed from public resources—checked out, they are easy to get.

[Reviewed by Mary McCabe]

Oceanography in Print  
58 pp.

free? from:  
Sailing Book Service  
34 Oak Avenue  
Tuckahoe, N. Y. 10707

Ricketts, Edward F., and Jack Calvin. 1952. BETWEEN PACIFIC TIDES. 3rd edition. Revised by Joel W. Hedgpeth. Stanford, Calif.: Stanford University Press.

A detailed account of the habits and habitats of the animals which live in the rocky shores and tide pools of the Pacific Coast. The book is invaluable for its reflection of the spirit of a remarkable man. John Steinbeck's foreword is also not to be missed.

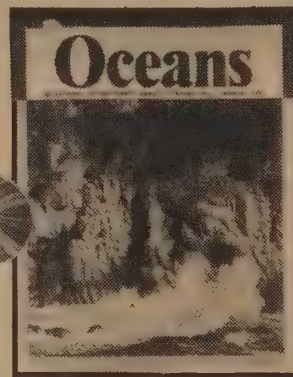

Oceans  
\$9/yr. (monthly)

from:  
Oceans Magazine  
P. O. Box 121  
Des Moines, Iowa 50301



Waves in deep water generally travel in groups or trains, separated by patches of comparatively calm water, rather than in a continuous series. A peculiar feature of the travelling groups is the successive disappearance of the leading waves and the corresponding appearance of fresh waves at the rear of the train. This results in the group advancing with a velocity that is only half the velocity of the individual waves. The newly created rear wave gradually works its way through the group to the front and then disappears. Perhaps there is some human analogy in this birth of a wave, its advancement through the group, and its ultimate death.

★ Sailing Book Service

Sailing Book Service provides a list of their publications—books dealing only with nautical subjects. It seems to be a super list, with some information that could be of use to anyone with ocean going aspirations.

[Reviewed by Mary McCabe]

Catalogs  
free

from:  
Sailing Book Service  
34 Oak Avenue  
Tuckahoe, N. Y. 10707

BOAT DESIGN (POWER)			
Aluminum Boats (Kaiser Aluminum)	114 pp	1964 Paper	\$ 5.00
Basic Naval Architecture (Barnaby) 5th ed'n.	508 pp	1967	16.50
Brochure of Pleasure Boat Design (Monk)		Spiral	3.00
Design and Construction of Small Craft (Dalgarno)	52 pp	Paper	2.00
Electronic Corrosion Control for Boats (Lenk)	128 pp	1966 Paper	2.25
Eliminating Engine Interference (Lenk)	112 pp	1965 Paper	1.95
High Speed Small Craft (Ducane)	462 pp	1964	16.50
Hovercraft Design and Construction (Elsley, Devereux)	262 pp	1968	12.50

"Every nautical book in print"

Pleasure Boating — Merchant Marine — History of Sail, Steam, Liners, Fighting Ships — Oceanography — Models — Skin Diving — Water Sports — Pirates — Wrecks — Natural History — Technical

**★ Low-Cost Wood Homes**

An excellent manual, with 100's of good drawings, on wood house construction. Details on pole house construction, and all aspects of wood frame buildings.

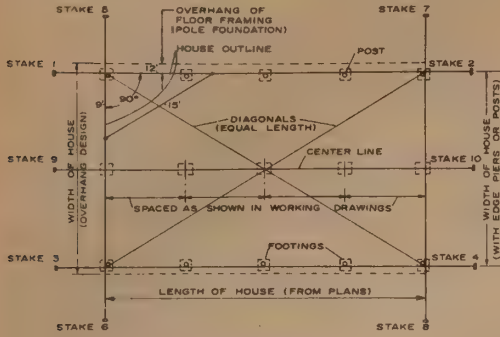

House & footing layout

**Low-Cost Wood Homes for Rural America—Construction Manual**  
L. O. Anderson  
1969; 112 pp.

**\$1.00** postpaid

from:  
Superintendent of Documents  
U. S. Government Printing Office  
Washington, D. C. 20402

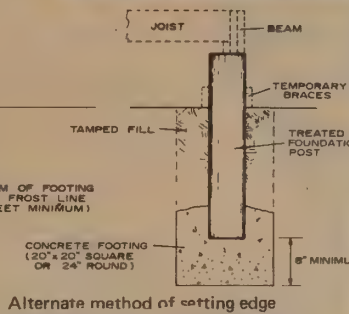

Alternate method of setting edge foundation posts: footing position

**★ Lumber and Wood Products Literature**

A bibliography of literature available on properties and uses of wood, with publications on timber construction, plywood, flooring, forestry and others.

[Suggested by Jerome Skuba]

**Lumber and Wood Products Literature free**

from:  
National Forest Products Association  
Technical Services Division  
1619 Massachusetts Avenue, N. W.  
Washington, D. C. 20036

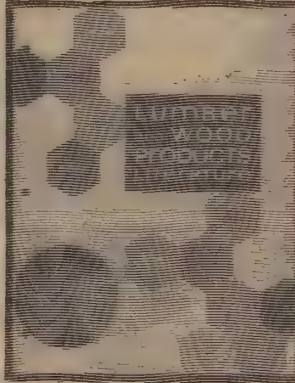

**POLE-TYPE BUILDINGS**

How to Design Pole-Type Buildings—Framing details of 12 types of structures. Data and equations for figuring stresses, loads, pole embeddings, sizes and other information. 68 pages. (Price \$1.50)

Low Cost Pole-Type Hangers—Portfolio containing complete woodworking plans, details, and instructions for erecting "T" shaped hangers. Directory listing pole-type building contractors included.. (Price \$3.00)

AWPI Directory of Pole Building Contractors—A list of experienced pole-building contractors throughout the country.  
—American Wood Preservers Institute

How to Build Pole-Type Frame Buildings—Details on how to lay out, design and build pole-type frame buildings for farm service. 12 pages.  
—Southern Pine Association

Timber Fastenings—Describes various timber fastenings, other than nails, in common use. Tables of bearing stresses, withdrawal resistance and safe loads  
—California Redwood Association

Construction and Analysis of Simple Hyperbolic-Paraboloid Shells of West Coast Lumber—Detailed information on an imaginative and striking structure, adaptable to many building applications. 8 pages.  
—Western Wood Products Association

**★ Concrete Manuals**

Three informative pamphlets on concrete from the Portland Cement Association:

**Cement Mason's Manual for Residential Construction** is primarily for home patios and walkways, with fundamentals on use of the transit, and instructions on finishing.

**Concrete Improvements for Farm and Ranch** is a good basic instruction manual, with details on many rural applications; how to build forms, tilt-up construction, water troughs, floors, etc.

**Design and Control of Concrete Mixtures** is an engineering bulletin, very detailed, on all aspects of quality control of concrete mixtures.

[Suggested by Fred Richardson]

All 3

free

from:  
Portland Cement Association  
Old Orchard Road  
Skokie, Ill. 60076

**Power Joint Cutter**

Another method of cutting joints in concrete slabs is with an electric or gasoline-driven saw fitted with a shatterproof abrasive or diamond blade. A power cutter produces a narrow joint that minimizes the possibilities of spalling at the joint due to traffic. The joint is cut in the concrete surface 4 to 12 hours after the concrete has hardened or as soon as the concrete surface will not be torn or damaged by the saw.

[Cement Mason's Manual]



Tilt-up concrete construction is accomplished by casting wall panels on a concrete floor or other relatively smooth bed and then tilting them to a vertical position. To prevent bond with the wall panel, the floor slab is covered with plastic film or a sprayed-on chemical. Wall panels are usually tilted by a tractor or other lifting equipment. The panels are braced and reinforced concrete columns are cast at the panel junctures to tie them together.

[Concrete Improvements]

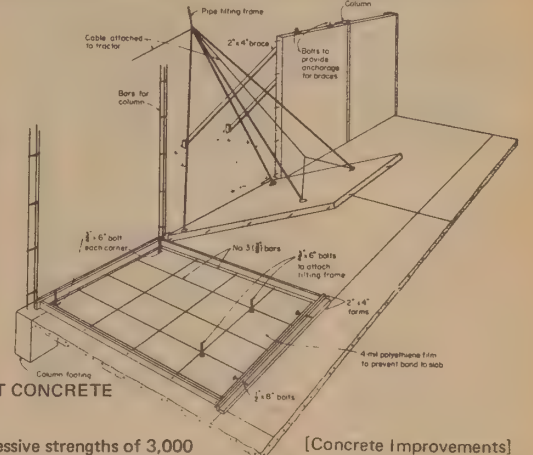

[Concrete Improvements]

**HARDENED STATE OF LIGHTWEIGHT CONCRETE**

**Compressive Strength**

Lightweight concrete with 28-day compressive strengths of 3,000 to 4,500 psi can generally be produced in the laboratory with cement contents of 425 to 800 lb. per cubic yard, depending on the particular lightweight aggregate being used. Certain lightweight aggregates can be used to make concretes with strengths of 7,000 to 9,000 psi and with cement contents of 565 to 940 lb. per cubic yard. The rate of strength development for lightweight concrete is approximately the same as that for normal-weight concrete.

[Design and Control of Concrete Mixtures]

**★ Blasting**

Explosives are a cheap, highly portable, concentrated source of energy, an industrial and agricultural tool and as such useable and useful to the amateur who has need of such tools. Dangerous? Yes, but only a small hazard with reasonable care. — consider as no more, NOR LESS, dangerous than a gun which has no safety and is never unloaded. Treat accordingly—particularly with regard to whom you allow to handle them! Can YOU use explosives? . . . Yes—with care. Will YOU be ALLOWED to? . . . Probably, but there ARE regulations and they vary too widely for generalisations.

What would you want them for? The possible answers to that question would surprise most people—the uses of explosives range from the moulding of NASA hardware to the manufacture of diamonds! For the amateur though the most likely uses will lie in the making of access roads, foundations, land clearance and drainage. For instance, \$25 worth of explosive will break up 150-400 tons of rock, or lift out and break up a dozen large stumps, or blow a ditch four feet deep, twelve feet wide at the top, tapering to four at the bottom and one hundred feet long. It is often, in outlying areas, cheaper to use explosives for a small drainage or creek diversion project than to pay the cost of getting a backhoe to the site. Also explosives can be used anywhere a man can go, which is often to places machines can't. Even for a simple job like digging a trench for a culvert, a few dollars worth of dynamite used merely to loosen hard-packed soil can easily make the difference between man days of pick work and man hours of shovel work.

The next question is: Where do you go for more information? And the answer to that is . . . your phone book, under "Explosives" in the yellow pages. Try first the nearest big company; du Pont has the most literature, Hercules seems the most helpful. Then try your nearest dealer, your local police, fire chief and Highway Patrol, in that order. Know before you pick up the phone what you want to do and simply ask for advice and help with the regulations to enable you to do it. It is, however, normal to find that about half the latter have little idea themselves, so persist until you have read your local regulations for yourself, if necessary writing to your state capital. It goes without saying that the most useful information anyone can give you is the address of a neighbor who is experienced in handling dynamite. If you are unlucky and have to work entirely from the book, don't worry too much—there isn't any reason why you shouldn't do so safely, with no more than common sense AND RIGID ADHERENCE TO THE BOOK'S INSTRUCTIONS. Without knowledge of the reasons behind the regulations and the book's "Do's and Don'ts", you must not deviate in the slightest. In particular your local regulations for transport, storage and use will be framed to reflect local conditions and hazards—every little detail MUST be scrupulously observed.

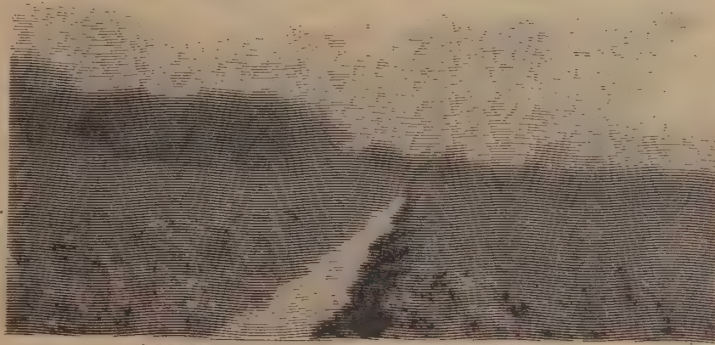

**SIMULTANEOUS EXPLOSION OF CHARGES MAKES DITCH**

If a single charge of dynamite is placed in the ground and exploded, the resulting hole is similar to an inverted cone. If a series of charges are placed in a row and exploded, the result is a series of overlapping inverted cones. If all the charges in a series are set off at the same instant, the overlapping material does not fall back into the holes and a complete trench is the result. It would be impossible to shoot this series of charges separately and get a satisfactory trench. When a ditch explosion takes place, the blasted material is thrown from 100 to 200

Practical literature is restricted to publications of the Institute of Makers of Explosive, 420 Lexington Avenue, New York 10017, handbooks from manufacturers and, for those who have \$6 to invest, *Blaster's Handbook* from E. I. du Pont de Nemours, Wilmington, Delaware or Canadian Industries Limited, Montreal, Quebec. Imperial Chemical Industries, Limited, Nobel Division, Stevenston, Ayrshire, Scotland, also provides a handbook entitled *Blasting Practice*. Whilst the handbooks admittedly contain everything, they necessarily therefore only devote a small fraction of their space to the needs of the amateur; moreover, being aimed at the professional, they are neither well laid out nor well written for anyone else. The publications from the Institute of Makers of Explosive, though irritatingly archaic, remain sound. Their pamphlets, "Safety in the Handling and Use of Explosives" (#17), "How to Destroy Explosives" (#21), and "Explosives in Agriculture" (#11), may cover most people's needs, with the addition of a pamphlet which, despite its small size and vaguely apologetic foreword, is a class above anything else in its field and a model of terse lucidity—"Efficient Blasting through the proper care and use of Safety Fuse" from The Ensign-Bickford Company, Simsbury, Connecticut.

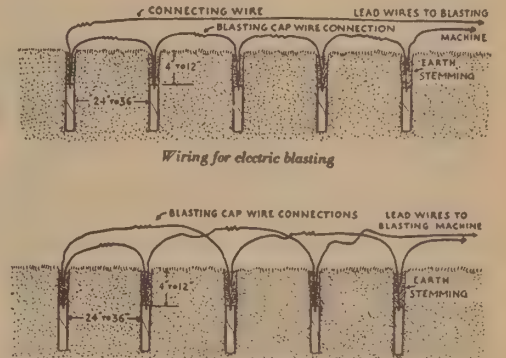

Two final points: if you want to blast near rail, power, phone or pipe lines, contact the owner; and if you have charged up your first blast and want to know how far to retire and discover that the books become suddenly vague at that point—well, half a mile is a nice round figure . . .

[Suggested and reviewed by Keith Britton, Advanced Blasting Company]



All free with the exception of the *Blaster's Handbook*

**Seeds and Trees by Mail**

Seeds are exquisitely designed instruction capsules for an orderly rearrangement of the elements. The gardener plays only a small role in the process—the seed tells the soil nutrients, air and water to organize into exactly what is described on the seed packet. Automation—and an example of what we've been given to work with on our planet. Write for brochures.

Vegetables and flower seeds. Organic fertilizers and insecticides. from: Natural Development Company, Bainbridge, PA 17502. *Tri-excel DS, a non-poisonous plant protectant for flowers, vegetables, berries, trees. It's made of ground-up flowers, resins, etc., and it works. The best all-around seed source.*

Organic Seeds. "Untreated, natural, old-fashioned, unhybridized, uncrossed." Several gardeners report that these seeds have not germinated as well as hybrid types.

Dwarf, semi-dwarf and regular fruit trees by mail. This is a 3,000 acre nursery, over 150 years old. from: Stark Brothers' Nurseries & Orchards, Louisiana, MO 63353

Davis Headquarters Forest Nursery, Rte. 1, Box 1410, Davis, California 95616. The state of California's distribution center for trees for reforestation, erosion, windbreaks. A long form of course, but they mail pines, cypress, fir, redwoods, eucalyptus in quantities of 100-1,000 or more. One year old bare-root trees (4-10" height) are as little as \$10 per 500.

Wildflower & Wild Tree Seeds. Gardeners and food growers—and maybe hunters and gatherers too—should check out Clyde Robin's seed catalog. It offers not only wildflowers, which grow easily without too much attention, but also many weird and unusual seeds of flowers, trees, shrubs, herbs, and vegetables, plus occasional information on their culture, appearance, uses, etc.

The Special Roadside Mixture grows in places where you thought only weeds would, and makes a really gaudy show in early Summer. After it has bloomed you cut it all down to the ground and the California poppies grow back and flower again. Grow catnip and turn your cats on—it grows easily from seed but you have to start the seedlings inside a small protective wire cage (which the plants will grow up through and out of) otherwise those dope-crazed cats rub out the young plants entirely.

\$.25 from: Clyde Robin, P.O. Box 2091, Castro Valley, CA 94546

[Suggested and reviewed by David Noton]

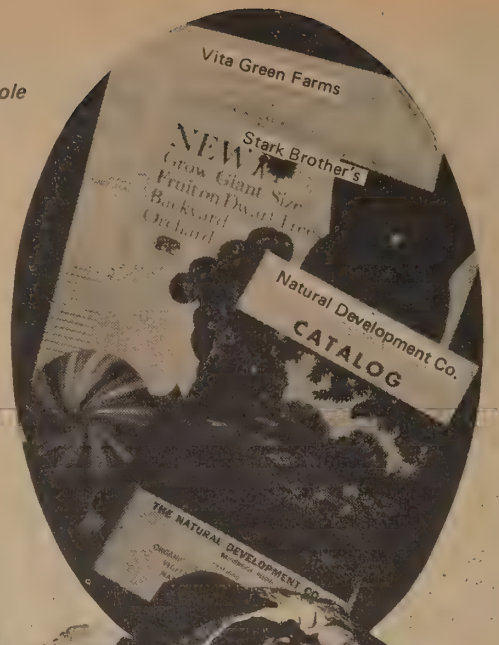

Not organic, but about the most complete vegetable and flower seed catalogue. Very fast and efficient service. from: W. Atlee Burpee Co., Riverside, CA 92502

Large complete catalogue, similar to Burpee. from: Stokes Seeds, Inc., Box 15, Ellicott St. Station, Buffalo, N. Y. 14205

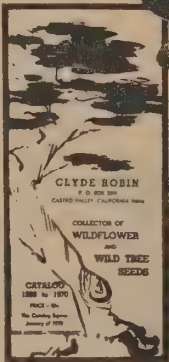

**Agricultural Publications**

Free information on farming, livestock, forestry, soil science, etc. On general requests not more than one copy each of 10 publications is sent. Justification is required if you want more.

- Grass. (Yearbook.) \$2.00. \*YB 1948
- Grass for conservation in the southern Great Plains. 1955. F 2093
- Grass makes its own food for growth, for forage, for good land use and for soil conservation. 1960. AB 223
- Loans for forestry purposes. 1964. PA 624
- Loans for water development and soil conservation. 1965. PA 554
- Loans to cooperatives serving rural families with low incomes. 1965. PA 552
- Loans to family farmers for recreation enterprises. 1963. PA 563
- Loans to rural groups. 1963. PA 560
- Growing pumpkins and squashes. 1963. F 2086
- Growing table beets. 1965. L 360
- Growing the Jerusalem artichoke. 1959. L 116
- Growing watercress. 1959. L 448
- Lettuce and its production. 1962. AH 221



**List of Available Publications \$ .40**

from: U. S. Department of Agriculture, Washington, D. C. 02050

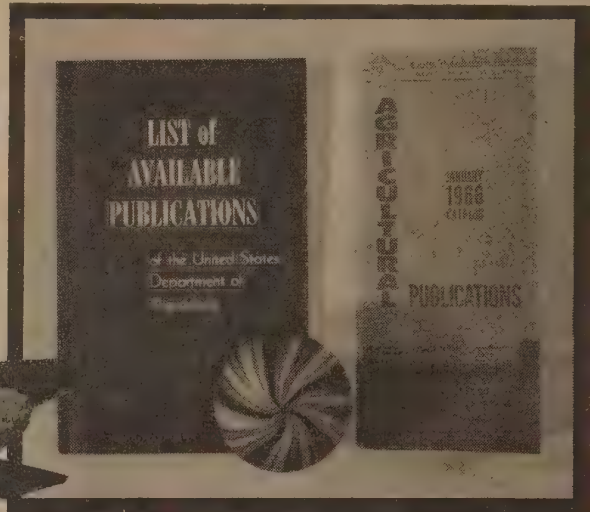

The University of California's Agricultural Experiment Station also has a batch of free pamphlets. You're entitled to 20 publications if a California resident, 10 if not.

**Agricultural Publications free**

from: Agricultural Publications, 207 University Hall, University of California, Berkeley, Calif. 94720



**Leaf. 116 Wild Rice**  
Instructions for growing wild rice for food or for the improvement of game reserves.

**Leaf. 131 Water Management in Rice Production**  
Suggestions for better land preparation and irrigation practices for rice growers.

**Leaf. 161 California Rice Varieties and Seed Selection**  
Describes the leading California rice varieties including experiments with long-grain varieties. For rice growers and members of the rice milling and marketing industry.

**C 408 The Border Method of Irrigation**  
Gives directions for designing, constructing, and using irrigation systems employing border checks.

**C 527 Handling Strawberries for Fresh Market**  
Discusses the things to do and the things to avoid to preserve quality in strawberries sold on the fresh market.

**WALNUTS**

**Leaf. 137 Nutrition and Fertilization of Walnuts**  
Discusses soil nutrients needed by walnuts and how to correct excesses or deficiencies.



837 Cosmos, Radiance

★ **A Modern Herbal**

*This is far and away the most complete (and expensive) information on herbs.*

*"The medicinal, culinary, cosmetic and economic properties, cultivation and folk-lore of herbs, grasses, fungi, shrubs and trees with all their modern scientific uses . . ."*

*Over 160 useful plants are listed—the history, description, constituents, medicinal uses, preparation, dosages, and even recipes of each.*

*It is a two-volume set, with a meticulously complete index of the common names of the plants, followed by a service index of Latin binomials.*

[Reviewed by Alan Schmidt]

Comfrey leaves are of much value as an external remedy, both in the form of fomentations, for sprains, swellings and bruises, and as a poultice, to severe cuts, to promote suppuration of boils and abscesses, and gangrenous and ill-conditioned ulcers. The whole plant, beaten to a cataplasm and applied hot as a poultice, has always been deemed excellent for soothing pain in any tender, inflamed or suppurating part. It was formerly applied to raw, indolent ulcers as a glutinous astringent. It is useful in any kind of inflammatory swelling.

. . . The reputation of Comfrey as a vulnerary has been considered due partly to the fact of its reducing the swollen parts in the immediate neighbourhood of fractures, causing union to take place with greater facility.

**ABC and XYZ of Bee Culture**

*The first edition of this authoritative book was written in 1877 by Mr. A. I. Root. The current edition, the 33rd, is edited by Mr. E. R. Root, with the help of H. H. Root and J. A. Root. You get the picture.*

*We've been told by several people that bee-keeping is one of the easiest ways to make extra money with little effort and a certain amount of down-home adventure. If you are what you eat, food from flowers is hard to beat.*

*From whatever standpoint—commercial, nostalgic, or amateur scientific—this is a fascinating and useful book. The Roots also have a catalog of bee supplies, a beginner's book (Starting Right With Bees), and a magazine (Cleanings in Bee Culture)—monthly, \$3.00 per year.*

[Suggested by Tassajara Zen Center]



ABC and XYZ of Bee Culture  
1877 . . . 1966; 712 pp.

\$5.50 postpaid from A. I. Root

or WHOLE EARTH CATALOG  
Starting Right With Bees  
100 pp.

\$1.00 postpaid from A. I. Root

or WHOLE EARTH CATALOG

Catalog  
free

from:  
The A. I. Root Company  
Medina, Ohio 44256

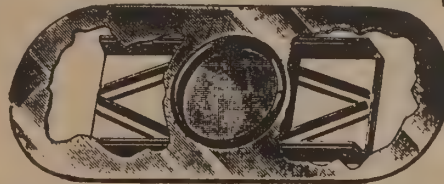

Porter bee escape. The two V-shaped prongs are made of thin strips of brass and are so sensitive that they spread easily to let the bees through at the apex. After the bees pass the springs, the points fly back to position, shutting off a return. If the prongs are bent or damaged they should be reset to 1/16-1/8-inch apart.

**A Modern Herbal**  
Mrs. M. Grieve, F.R.H.S.  
1931 . . . 1967; 2 Vols, 888 pp.  
**\$25.00**



from:  
Hafner Publishing Co., Inc.  
31 East 10th Street  
New York, N. Y. 10003

or WHOLE EARTH CATALOG

**Nettle.**

It is a strange fact that the juice of the Nettle proves an antidote for its own sting, and being applied will afford instant relief.

From a culinary point of view the Nettle has an old reputation. It is one of the few wild plants still gathered each spring by country-folk as a pot-herb. It makes a healthy vegetable, easy of digestion.

The young tops should be gathered when 6 to 8 inches high. Gloves should be worn to protect the hands when picking them. They should be washed in running water with a stick and then put into a saucepan, dripping, without any added water, and cooked with the lid on for about 20 minutes . . . they thus form a refreshing dish of spring greens, which is slightly laxative. In autumn, however, Nettles are hurtful, the leaves being gritty from the abundance of crystals they contain.

An efficient hair tonic can be prepared from the Nettle: simmer a handful of young Nettles in a quart of water for 2 hours, strain and bottle when cold. Well saturate the scalp with the lotion every other night. This prevents the hair falling and renders it soft and glossy.

Dandelion. The shining, purplish flower-stalks rise straight from the root, are leafless, smooth and hollow and bear single heads of flowers. On picking the flowers, a bitter, milky juice exudes from the broken edges of the stem, which is present throughout the plant, and which when it comes into contact with the hand, turns to a brown stain that is rather difficult to remove.

. . . In Berkshire and Worcestershire, the flowers are used in the preparation of a beverage known as Dandelion Wine. This is made by pouring a gallon of boiling water over a gallon of the flowers. After being well stirred, it is covered with a blanket and allowed to stand for three days, being stirred again at intervals, after which it is strained and the liquor boiled for 30 minutes, with the addition of 3 1/2 lb. of loaf sugar, a little ginger sliced, the rind of 1 orange and 1 lemon, sliced. When cold, a little yeast is placed in it on a piece of toast, producing fermentation. It is then covered over and allowed to stand two days until it has ceased "working," when it is placed in a cask, well bunged down for two months before bottling. This wine is suggestive of sherry slightly flat, and has the deserved reputation of being an excellent tonic, extremely good for the blood.

. . . Dandelion roots have long been largely used on the Continent, and the plant is cultivated largely in India as a remedy for liver complaints.

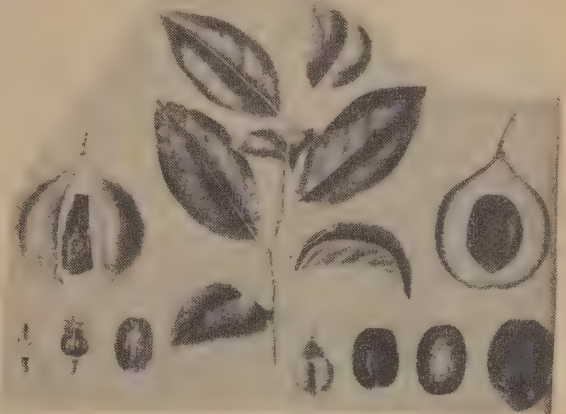

Nutmeg  
*Myristica Fragrans*

**Climates of the States**

*Specific climatological data on each state: rainfall, temperature, freeze occurrences, winds, etc.*

\$25 for each state.

from:

U.S. Govt Printing Office Bookstore  
Rm 135 Federal Building  
601 East 12th St  
Kansas City, Missouri 64106

U.S. Govt Printing Office Bookstore  
Federal Building  
450 Golden Gate Avenue  
Rm 1023 Box 36104  
San Francisco, California 94102

U.S. Govt. Printing Office Bookstore  
710 North Capitol Street  
Washington, D. C. 20402

U.S. Govt Printing Office Bookstore  
Rm 1463 14th floor  
Federal Office Building  
219 S. Dearborn St.  
Chicago, Illinois 60604

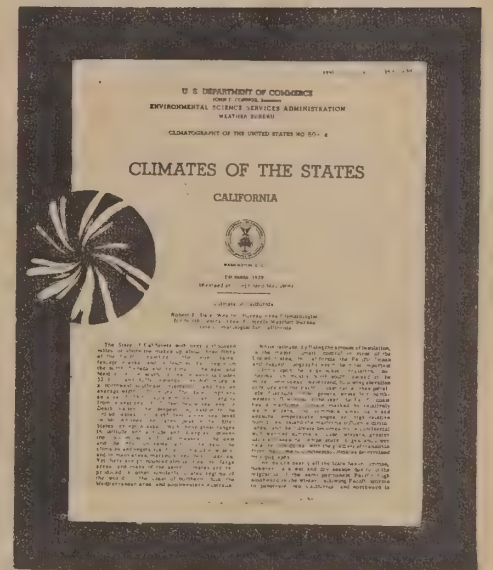

**Normal Annual Total Precipitation (Inches) -- California**

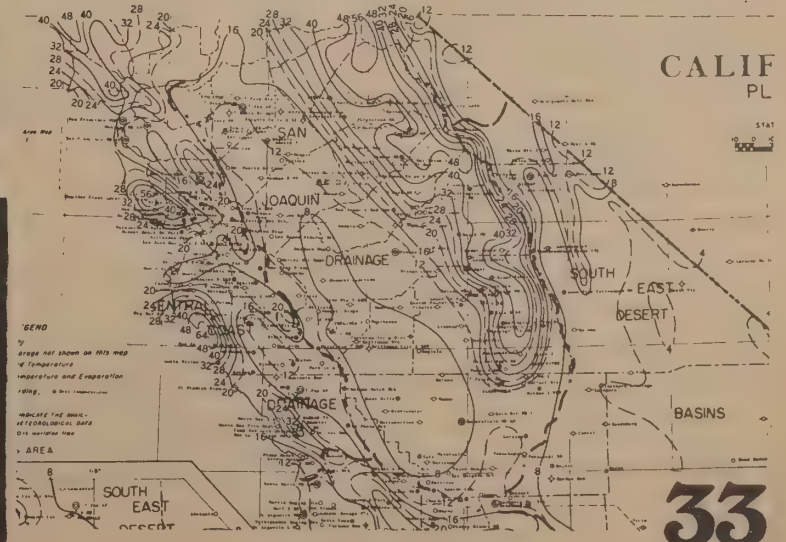

## Organic Gardening & Farming Magazine

A monthly information exchange among gardeners who do not use artificial fertilizers or poisonous insecticides. Keeps you current on new techniques and discoveries.

The ads are valuable, telling you where to get seeds, farm machinery, etc.

I save tall fruit-juice cans for protecting transplants, and like them also for their electroculture value. Last year, after shading my broccoli and collards against transplanting shock, I left the cans between the rows in an experiment with electroculture. Soon the cans were hidden by lush growth, the plants reaching 3 feet or more.



I was ready to give up on growing corn any earlier. Then one day when I was trying to figure out what I should do with a stack of corrugated clear-plastic panels left by the former owner of our home, I got an idea. Why not bend the panels to make covers over the rows of my early corn? The plastic would make a sort of miniature greenhouse over the plants, keeping out cold air but letting sunlight flood in to warm the soil. Furthermore, the panels would keep out pesky crows, blackbirds and rabbits.

The idea worked like a charm.

### Reports on new equipment:

When we called, the Gilson team was taking the wraps off a highly-experimental, pint-sized shredder. It has a very low center of gravity, is extremely mobile and light. Powered by a 3-h.p. engine, the Gilson composter features an idler clutch and an effective mixing and cutting chamber.

### And editorials:

When you look at a plant growing in your garden, you do not see at once all the things which make it possible for that plant to thrive. But no living thing on this planet grows in isolation. Plants, animals, insects and people are all linked together in a web of life, with air, water, soil, minerals and other natural resources also playing vital parts. There is a cycle, a rhythm, to life.

One lesson that we are now learning is that the web of life is made of very fine strands. Upsetting the life patterns of only one type of plant or animal, even in a small way, can have an effect on many other living things.

## Organic Gardening & Farming

\$5.85 for one year, monthly  
\$0.60 per copy

from:  
Rodale Books, Inc.  
33 East Minor Street  
Emmaus, PA 18049

## Encyclopedia of Organic Gardening

The Encyclopedia of Organic Gardening  
J. I. Rodale & Staff  
1968; 1145 pp.

\$10.19 postpaid

from:  
Rodale Books, Inc.  
33 East Minor Street  
Emmaus, PA 18049

or WHOLE EARTH CATALOG

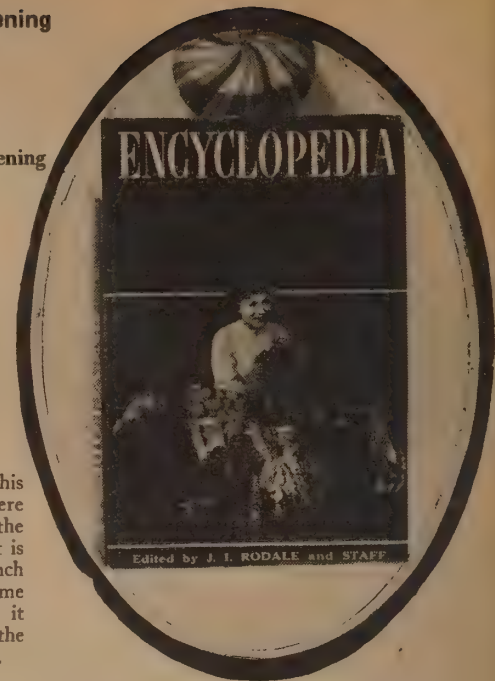

WHIP OR TONGUE GRAFT: This appears to be the best method where the stock and scion are close to the same thickness. When the stock that is to be grafted is greater than 3/4-inch in diameter, it is best to use some other form of grafting because it would be very difficult to make the proper cuts with the grafting tools.

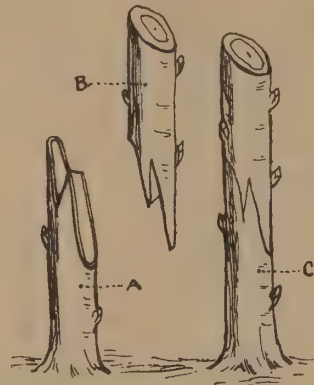

A permanent reference book, compiled from years of magazine issues. How to plant, cultivate, fertilize and harvest. Thousands of subjects: composting, mulching, soil acidity, pruning, vegetables, fruit and nut trees, insect control, earthworms, etc.

I cross-reference anything useful in the magazine with the Encyclopedia, this keeps me up on latest information on the subject.

The Encyclopedia and How to Raise Fruits and Vegetables by the Organic Method (below) are both indispensable: the former has many more subjects, the latter goes into greater detail.

[Suggested by Lama Foundation]

## Organic Gardening

In the month that I have had my copy of How to Grow Vegetables and Fruits by the Organic Method, I have browsed in it and referred to it for so many different reasons, out of so many different moods, that I can't decide if its resting place on the shelf is among my other "how-to" books or somewhere between the poetry and books on oriental religion.

But I shall worry about that problem when the time comes, if it does. Right now I'm digging into it so often and with such delight it doesn't need a place on a shelf. I keep it in handy reach on the dining room table.

This book is the definitive manual on organic gardening. It is loaded with information, 550,000 words spread over 926 pages. It is wonderfully illustrated with pictures that are precise and useful, as well as pleasing to the eye. In a pleasant, relaxed prose style, the style of people who obviously have spent more time in the garden than in the library but who at the same time are so confident of what they're saying their words ring hard and true, the editors of this manual have gathered together every fact that one would need to know to become a successful organic gardener, almost anywhere in the United States.

This book has another quality one does not always find in gardening manuals: it is well organized. The first part is about the soil; the second part is about vegetables, the third part is about fruit, and the closing pages are devoted to nut culture and herbs.

In Section one, there are chapters on how to improve the soil; make compost; start plants from seed; watering and irrigation; when to harvest; fall and winter gardening; controlling insects; greenhouse gardening.

Section two looks closely at some 100 vegetables, giving a page to each vegetable, artichokes through zucchini, and what amounts to a brief essay that describes the history, vitamin content and how to raise each individual vegetable.

Another section does the same with some sixty varieties of North American fruit, from apples and apricots to watermelons and youngberries.

In addition, there are scores of charts and graphs that provide a complete planting guide for all the listed vegetables and fruits. Each geographical region of the United States and its peculiarities are accounted for. One table, for instance, is titled, "Planning Guide for a Family of Five in Washington." Categories of information for gardening in Washington include planting dates, growing period, length of the garden row, amount of seed, depth to plant, distance between rows, and distance between plants.

The entire book is that detailed on every subject it takes up.

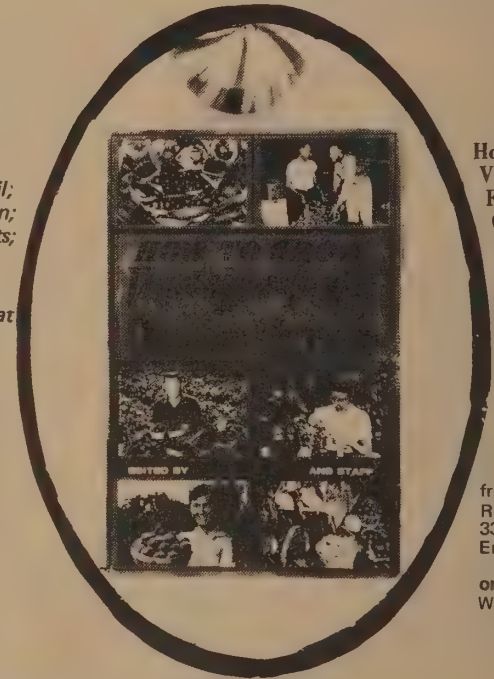

How to Grow Vegetables and Fruits by the Organic Method  
ed. J. I. Rodale and Staff  
1961; 926 pp.

\$10.19 postpaid

from:  
Rodale Books, Inc.  
33 East Minor St  
Emmaus, Penna

18049

or  
WHOLE  
EARTH  
CATALOG

## Vitamin Losses

Vegetables to be cooked should be handled in the same manner as salad vegetables. Gather immediately before using or else wash, dry and store in a cool place. If they are left at room temperature and in the light, much folic acid, vitamin B<sub>2</sub> and 50 per cent or more of the vitamin C in most fresh vegetables can be lost in a few hours.

## Inoculate Garden Legumes

If you are planning to grow any beans, peas or peanuts in your garden this spring, why not take time out to inoculate the seed with nitrogen-gathering bacteria? It will certainly be worth your while.

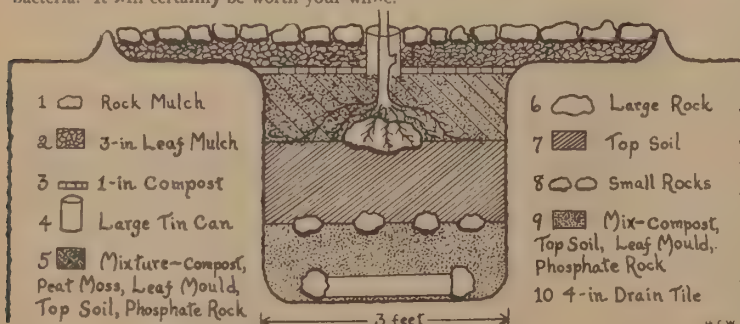

Several "secrets" are involved in this diagram. In addition to digging an outside hole and using the large center stone, you also mulch with rocks and leaves and install adequate drainage.

## A Tier-Shelf Bed for Mushrooms



One need not, however, intend raising food for a family of five before this book can be useful to you, and a pleasure. I find it absolutely stimulating just as reading matter. It's pleasing in the way that thumbing through a catalog filled with delights you crave can be pleasing. Browsing in this book reminds one of fundamental things, of soil and water and air, and one's own involvement in the natural scheme of the world. The book is beautiful in the way that native crafts are beautiful: it's alive aesthetically at the same time that it's useful. That's more than one can say about most novels. I own very few books I'd rather have than this one. I recommend it to gardeners of all shapes and sizes, and to aware people in general who enjoy reading books whose themes, images and metaphors are drawn from the world of nature.

[Reviewed by Gurnev Norman]

But we are more concerned here with the "meat-eaters"—birds which prefer to eat millions of insect life. A few birds prefer an all-insect diet. They include barn swallows, swifts, house wrens, grackles, flycatchers, brown creepers and some of the several species of warblers. Their bills are long and straight, or long and curved; or they may be short and whiskered; whippoorwills and the nighthawk family belong to this group.

## How to Have a Green Thumb Without an Aching Back

A classic in organic gardening. Now in her 80's, Ruth Stout is still telling gardeners how to take it easy; mainly by using her home-devised mulching system, which is purported to eliminate composting, weeding, watering, tilling, digging, and worrying. Briefly, it amounts to covering ground around vegetables with about 8" of organic matter (such as hay), which keeps weeds down, moisture in, ground soft, and worms working.

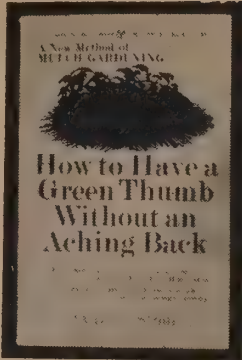

**How to Have a Green Thumb Without an Aching Back**  
Ruth Stout  
1955; 160 pp. (dk. green text)

\$1.45 postpaid

from:  
Cornerstone Library Publications  
Simon & Schuster, Inc.  
630 Fifth Avenue  
New York, N. Y. 10020

or WHOLE EARTH CATALOG

## Soil Test Kit

A soil test kit enables you to test your garden soil for acidity/alkalinity, nitrogen, phosphorus, and potash. A test will show what is present and what is lacking. There are test tubes, chemicals, and a color chart to gauge results. Be sure to ask for "The Organic Supplement" prepared by Organic Gardening magazine in case "...you have decided to work with Nature's own methods of fertilization." Feed the soil, not the plant.

If the soil is too acid, it may be brought back to a favorable pH (acidity-alkalinity balance) by addition of ground limestone or dolomite.... Soils which are too alkaline can be corrected with organic matter, which produces natural acids directly as it decays.

Nitrogen is responsible for producing leaf growth and greener leaves.... One of the easiest and most effective ways of adding nitrogen and building soil fertility is growing and turning under foliage crops such as clover, vetch, alfalfa, etc.

Phosphorous...is important for a strong root system, for brighter flowers and good growth.... You can best add phosphorous to your soil with finely ground rock phosphate.

Potash, the third major nutrient carries carbohydrates through the plant, helps form strong stems, and fights disease. Major natural sources of potash are fly ash, wood ashes, granite dust, seaweed, etc.

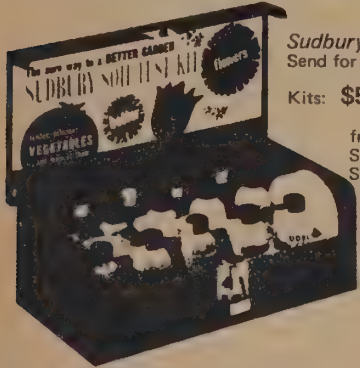

**Sudbury Soil Test Kit**  
Send for descriptive literature

Kits: \$5.95-39.95

from:  
Sudbury Laboratory, Inc.  
Sudbury, Mass. 01776

## Pruning Handbook

This booklet starts with a basic description of the way plants grow, lists pruning tools and their uses, and describes pruning systems for ornamental and fruit trees, berries and grapes, roses and vines.

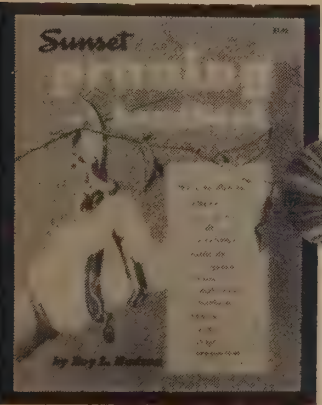

One way to learn the fundamentals of pruning is to study the mistakes that other gardeners make.

General objectives of pruning have to do with modifying the growth of the plants to adjust it to the conditions of the garden.

**Pruning Handbook**  
Roy L. Hudson  
1969; 80 pp.

\$1.95 postpaid

from:  
Lane Magazine & Book Company  
Menlo Park, CA 94025

or WHOLE EARTH CATALOG

Heavy pruning of the apricot is essential to insure regular fruit production. One-year old shoots produce a portion of the crop, but short-lived spurs carry the major portion. As these spurs are usually good for only three years, they must constantly be renewed. The tree, in suitable areas, is a very lush grower and a heavy bearer. Unless kept in severe check, it will rapidly become too large and will bear its fruit high in the tree where it cannot be thinned or picked easily. The lower spurs will be shaded out by the lush foliage and new ones will not form. In short, you would have a fine shade tree but a very unsatisfactory fruit tree. The necessary pruning for good fruit production does not always develop a graceful garden tree.

## Goat Husbandry

An interesting book but in browsing thru it, looking for key information, I realized that the free pamphlet, **Your Dairy Goat** put out by the USDA, available at any Agricultural Extension office, has all the necessary, immediate information needed by the individual, or community to go into the home goat business. The price of the book will, in many parts of the country, buy a goat.

(personal footnote, if you want it) Goat owners are a lot like horse traders. Be careful. Seek out experienced advice. If possible, have someone whose opinion you trust along with you when buying a goat. If you are paying fifty dollars or more, as is sometimes necessary, for your goat, invest in a vet's inspection and opinion if at all possible.

My preference is unquestionably Toggenburg. A three year old doe whose milking and kidding record is available is most desirable. Toggenburg crosses cut the price in half and by selecting bucks you can breed back to almost pure strain in a few years. (Toggenburg on the doe's side as that's who determines milk production.) A last word: if you are in the market for goats you probably already like them. They are almost all beautiful animals. When I first got into goats I bought a nice three year old Alpine doe just drying up. She looked like an antelope. Beautiful. She did dry up shortly. I bred her, fed her for five months. She had trouble kidding and her milk production was poor. Nothing I could do in the way of feeding and milking schedules helped. I still had a beautiful pet goat but awfully expensive. Somehow I like the good milkers more.

[Reviewed by Steve Katona]



**Your Dairy Goat**  
free

from:  
University of California  
Agricultural Extension Service  
Public Service Office  
141 Administration Building  
University of California  
Davis, California 95616

Because goats are dairy animals, they must have dairy characteristics. Check to see that the doe has a feminine head, thin neck, sharp withers, well-defined spine or backbone and hips, thin thighs, and rather fine bones. The skin should be thin and fine over the ribs. Look for a wide spring of rib and roomy barrel. This will help you to know how much feed she can eat. The constitution, or physical nature, is an important item shown by the depth and width of the chest. It's important to look at the udder, too. It should be large when full of milk and very much smaller when empty. A large udder does not always mean a high milk yield.



**Goat Husbandry**  
David Mackenzie  
1967; 368 pp.

\$15.75 postpaid

from:  
Transatlantic Arts  
Trade Dept.  
North Village Green  
Levittown, L. I., N. Y. 11756  
or WHOLE EARTH CATALOG

## Rural Industry

This guide catalogs several hundred tools, all manufactured or distributed by CeCoCo (Central Commercial Co.), and all applicable to what they term "cottage industry". In quaint English translation CeCoCo editors spell out the small scale cottage industry concept:

Small-Scale Cottage Industry belies its name by providing a large proportion of all industrial employment and accounting for the great majority of all industrial establishments. However, it is often asked whether such industry can survive and perform a useful function in the highly industrialized regions of the world, and what its place should be in the economic plans of developing countries. Analysis of the exact nature of the problems facing small-scale industry and of the way in which it is adapting itself to meet them. Far from being moribund, small-scale industry is a dynamic force with a valuable role to play in the modern economy of both highly industrialized regions and developing countries.

In almost all developing countries in the world, there are determined efforts to achieve material economic progress and emphasis is being carried out to induce a shift in the structural pattern of the economy from one basically agricultural to one that is agro-industrial in character to assure an increasing level of national production within the framework of economic and social stability which does not require much of foreign exchange to insure its growth. That is very important to select such industries which do not need foreign exchange in obtaining raw materials.

The high cost of living in the urban areas, nevertheless reduces the workers' real income. Money incomes in the rural areas is lower than those in cities but the cost of living is equally lower compared with urban living. The full development of cottage industry in the rural areas, can provide additional forms of incomes on the part of rural families, which could reduce the influx of population to cities in quest for employment. This ultimately would minimize social problem in urban centers.

The tools listed in this catalog are absolutely fascinating. One spends hours studying specifications, diagrams and photos of CeCoCo "making" machines. (In the Wire Products section, for instance, one finds Paper Pin Making Machine, Staple Pin Making Machine, Hair Pin Making Machine, Safety Pin Making Machine, Snap Button Making Machine, Nail Making Machine, Barbed Wire Making Machine, Chain Making Machine, Zip-Fastener Making Machine, Etc.)

CeCoCo was established in 1916, but refers to an association with a manufacturer of animal-drawn farming implements since 1863. They maintain an exhibition and demonstration farm center at Ibaraki. On the back cover of their guide book one sees photos of dignitaries from all countries of the world visiting CeCoCo center.

Some of the diesel and kerosene driven farm implements, and manually operated equipment proved to be especially pertinent to this reviewer.

[Suggested and reviewed by Ken Kern]

## "CECOCO" MOTORLESS HYDRO-HI-LIFT PUMP

This particular pump will raise water by the power caused by means of declivity of water-flow up to the height 30 times of water head and operates automatically without any motive power such as gasoline, other fuel oils and electricity and no attendance for operation is necessary. It is extensively used in Japan for water supply at home, and field for irrigation, spraying and water reservoir on the top of mountain and hill.

PRINCIPLE: In order to raise the water automatically by multiplied power of (1) the water hammer pressure leading pipe installed with a slight inclination and (2) the specific gravity with effectivity of the air in the delivery pipe taken in by the negative pressure (Vacuum) caused by the reactional flow of the water hammer pressure.

HOW TO INSTALL: Although it is motorless, it has to have a flow of water as the source of power to operate the pump and the "head" is absolutely necessary. During operation, proportionate amount of water to be delivered, therefore it must have drainage. The gist of such parts are:

- (1) Head 0.5-4 meter for small type and 1-8 meter for large type is considered to be the best for practical use.
- (2) Leading Water Pipe: The length of leading pipe is, for practical use, approximately 8 times of the Water Head and the pipe must be kept straight. It needs to be hard, therefore it is advisable to use steel pipe.
- (3) Delivery Pipe: The size of the delivery pipe is half in diameter of the leading pipe.
- (4) Drain Well: In order to cause counter current at the moment Drain Valve opens, it is necessary to install Drain Well. Also, in order to take the air, make the water level of drain well equal to red line marked on discharging mouth.
- (5) Discharging Water: It may be drained out into well or culvert or any other suitable equipment.

**Guide Book for Rural Cottage and Small and Medium Scale Industries**  
158 pp.

\$5.50 postpaid

from:  
CeCoCo  
Ibaraki City  
Osaka Pref.  
Japan



Illustration of Parts  
1. Leading Pipe (Aqueduct)  
2. Valve Chest  
3. Drain Valve  
4. Delivery Valve  
5. Air Chamber  
6. Delivery Pipe  
7. Drain Well

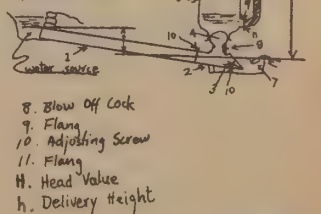

[Suggested by Fred Richardson]

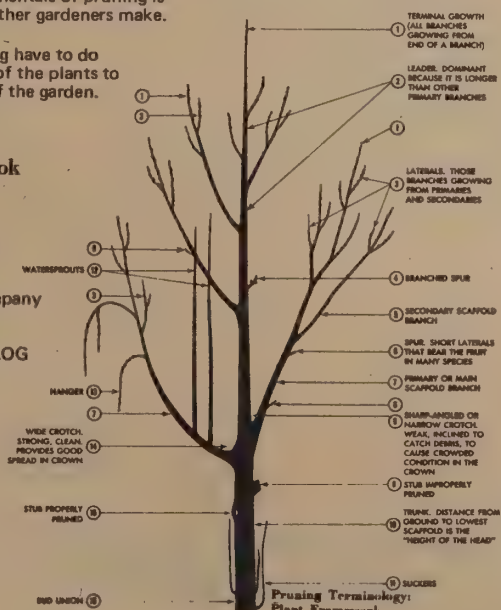

# Sundry Materials

We're going to attempt an information exchange on materials for builders, designers and dreamers. The fall-out from the space program is finally getting close to our fingertips; we can help each other with access information. So let us know if you've anything to add.

## Foam Experiments

Plastic foams are entering the building industry. Shot from guns, poured into molds, or vacuum formed, foam is produced by mixing two liquids which expand to form the cellular structure.

Recent technological advances with urethane foams in application, fabrication, and product control have led to the current wave of experimentation. Designers such as Douglas Deeds and Felix Drury are working on structural applications of foam, hoping to achieve free-form buildings.

Equipment for spraying is expensive: a foam rig is \$1,500-7,000, and foam itself runs about 10¢ per board foot (1" x 12", one inch thick) if you're doing your own application, and buying bulk materials. Its biggest applications now are in roofing and as insulation.

This book describes a government sponsored project to determine the potential use of foam for housing in underdeveloped areas. It may well be that building codes, unions, lumber lobby interests, etc., will hold up foam development in the U. S., and that the real advances will be made in other countries. Details are given here on several years of testing various structural applications of polystyrene and polyurethane foams. There are pictures, construction details, drawings, graphs and charts on test results. Since this work was done several years ago, recent improvements in foams may have superceded some of the conclusions.

[Suggested by Ron Brooks & Ron Swenson]

Although techniques have played a major role in the research program, this report is intended to be primarily a discussion of ideas rather than techniques.

It is clearly to the interest of the plastic industry in the United States to enter the housing field on such a global scale. As the section on marketing aspects brings out, the industry is caught in a squeeze between steadily increasing surplus production capacities and a falling price curve for the basic chemicals. Housing looms as a most attractive mass market—chemicals would be bought by the ton, not just by the pound—but attempts to penetrate the housing field in the United States have been frustrated because of local building code restrictions and the opposition of established interests in the conventional way of building. In entering the housing field, the plastics producers will find better opportunities for success if initially they turn to the emerging countries where the building codes are less restrictive (if indeed any exist at all) and where there is consequently more freedom to develop a new kind of building industry.

Foam inflation: a double walled bag, tailored in such a way that when foam components are placed in the bag they expand and inflate the structures. These bags can be made from polypropylene and milar films, tightly woven nylon fabrics, vinyl-impregnated fabrics...

All the shells were coated with liquid elastomer before being exposed to the weather. Two approaches were used. One was the use of the two-coat system, neoprene and Hypalon, and the other the use of two coats of Hypalon.

The shells were moved to the site by rolling each one like a giant wheel.

The shell was suspended and loaded with 20 lb sand bags to simulate uniform loading.

Petroleum is becoming increasingly the raw material for plastics intermediates.

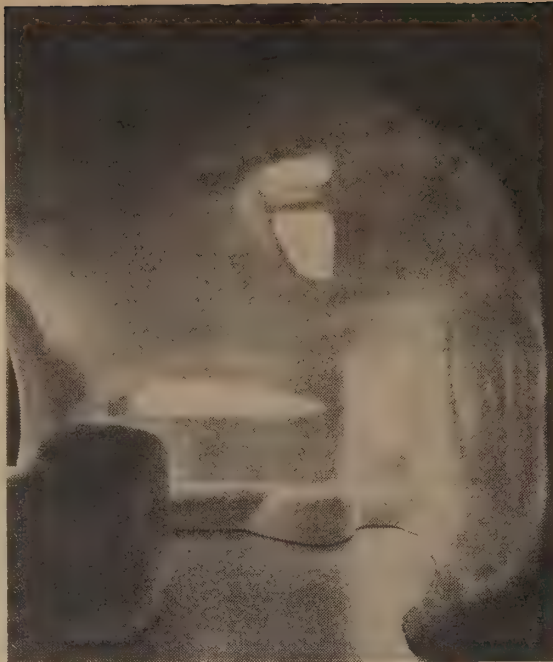

Office room transformed into grotto by designer Douglas Deeds, San Diego. Deeds built foam up in layers, as coils of clay are used to form a pot.

Closed cell foam plastics offer excellent thermal insulation (with K-factors usually varying from 0.12 to 0.30) low water absorption and low moisture permeability.

Plastic materials, particularly the foam plastics, unquestionably have a high potential for housing use in the developing areas of the world.

Spray techniques have good possibilities for the construction of total structures using either air-inflated structures or lightweight armatures as form work; the present crude appearance of sprayed foam products can be overcome by mechanizing the spray gun or by using extremely skilled operators.

Vacuum forming: ABS foam, marketed by U.S. Rubber Co. under the name 'Expanded Royalite'...in sheet form is clamped in a stationary frame, heated, and then drawn into a female mold by vacuum....

The fewer the joints, the fewer are the problems the structure will have to face...lightness in structures can lead to some special problems of anchorage.

The cellular plastics admittedly have certain technical limitations. For instance, they have a low moduli of elasticity and high creep characteristics. These properties definitely restrict the way they can be formed or shaped, if they are to be used as independent structural materials.

Figure P-2. INITIAL TEST STRUCTURES UTILIZING PAPER-LAMINATED POLYURETHANE FOAM BOARD

NOTE: PAPER-LAMINATED URETHANE FOAM BOARD IS 2.5 LB/FT<sup>3</sup> (40 kg/m<sup>3</sup>)  
NOMINAL CORE DENSITY 69 LB KRAFT FIBER  
LINER BOARD SKINS

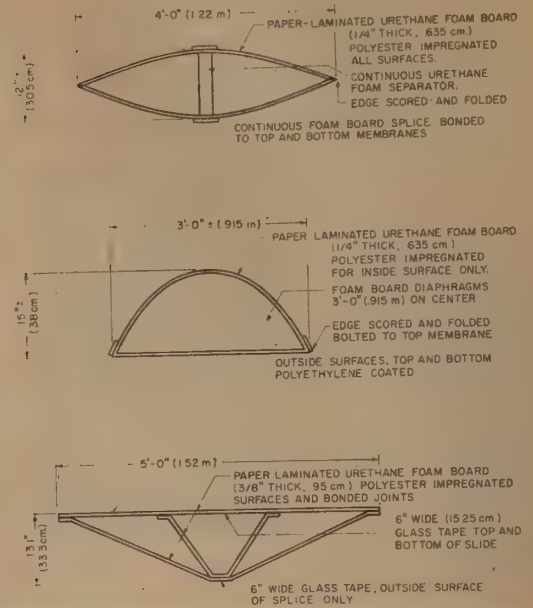

## Other Foam Information

### Home Foam

Rigid fire retardant 2 pound polyurethane foam can be poured by mixing two liquids. Best source for low cost foam and good advice on proper technique:

Lloyd Fox  
Douglas & Sturgess  
730 Bryant Street  
San Francisco, CA

### Misc. Foam Literature

A pile of current and excellent information on foam: The John A. Hartsack Papers, and Olin bulletins GD1 005, 008, 009, 011, 012A, 013A, and 015.

from:  
Richard W. Gaetjen  
Technical Sales Representative  
Olin Plastics  
Benicia Industrial Park  
P. O. Box 847  
Benicia CA 94510

Specific Foam systems applications, formulations and techniques:

William R. White  
Flintkote Company  
Sealzit Division  
4075 Main Street  
Riverside, CA

Free Brochure 'The Use of Rigid Urethane Foam as a Structural Insulant'

from:  
Mobay Chemical Co.  
Penn Lincoln Parkway West  
Pittsburgh, PA 15205  
Attn: Mr. Byron E. Beard

General foam info. from:  
Yellow pages, your phonebook for local foam applicators.

### Foam Guns

from:  
Sealzit Division/The Flintkote Co.  
P.O. Box 5347  
Riverside, CA  
Attn: W. R. White

### Foam Design

Deeds Design  
Associates  
1706 West Arbor  
Drive  
San Diego, CA  
92103



## Fiberglass

Ultra high-strength aerospace fiberglass, much stronger than conventional fiberglass

Technical Bulletin Ferro S-1014

from:  
Ferro Fiberglass Corp.  
Fiber Glass Road  
Nashville, Tenn. 37211

Boat builders fiberglass products—epoxy putty, glass tape, resin etc.  
from:  
Glass Plastics Marine  
200 Sayre Street  
Rockford, Ill; 61101

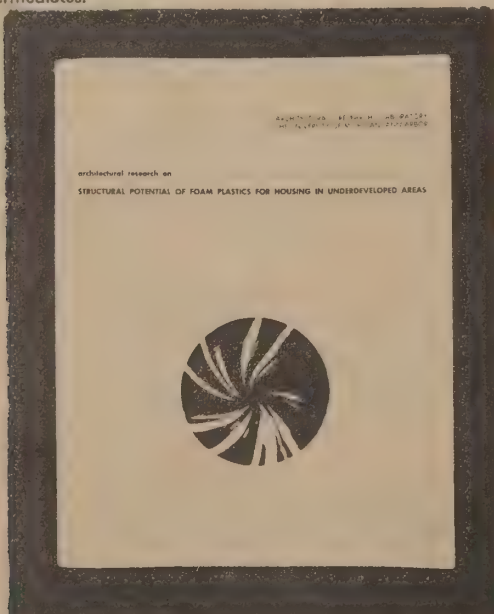
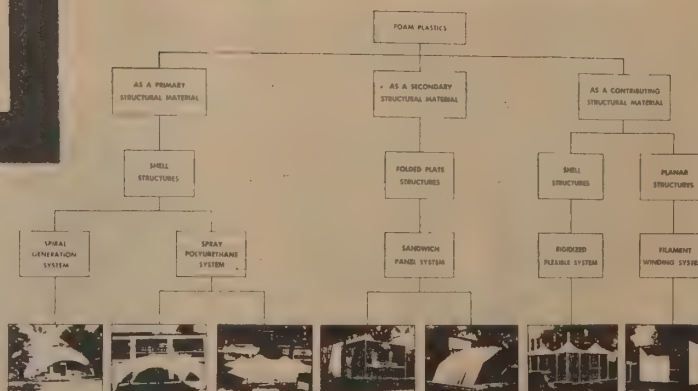
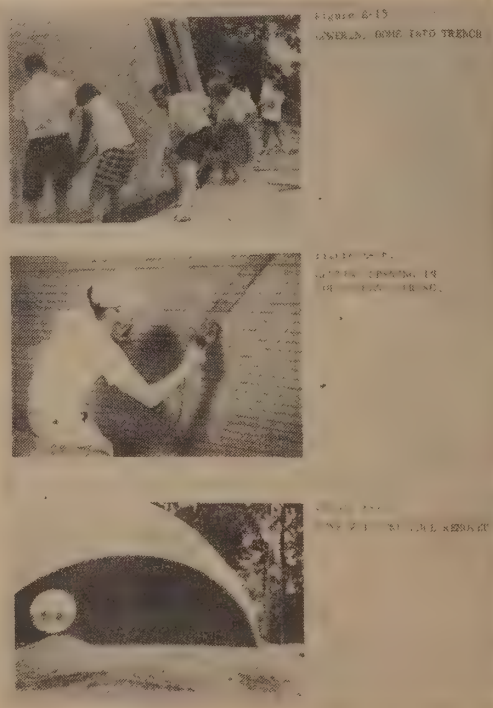

Architectural Research on Structural Potential of Foam Plastics for Housing in Underdeveloped Areas  
Architectural Research Lab.  
1966; 224 pp.

\$5.00 plus postage from:  
Publication Distribution Service  
University of Michigan  
615 East University  
Ann Arbor, Michigan 48106

## Sealants—Caulking Compounds

This company deals with all major manufacturers so they don't have to push one product. They have an incredible amount of information on caulks. We're using their polyurethane caulk for our dome seams; it's reportedly as good as silicon and half the price. About \$2.00 per tube.

Information from:  
Melvin Dressel  
Harold A. Price & Co., Inc.  
P.O. Box 1389  
Richmond, CA 94802



VULKEM 230 (125) Meets Specification TT-S-230 GUN GRADE, NON-SAG VULKEM 230 not only meets the Federal Specifications, but also provides the very high resiliency required for successfully bonding working joints. Bonding precast concrete members and bonding masonry to aluminum are typical proven applications. This product also is suitable for bonding metal to metal as in the production of campers and in assembling galvanized air conditioning ducts. VULKEM 230 never loses bond, even in horizontal joints which remain wet for a long time. Available in white, gray, aluminum and brown.

### JOINT DESIGNS

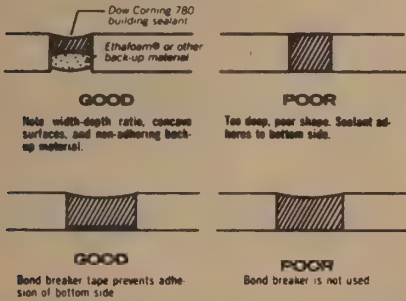

The depth of the sealant should never exceed one-half its width, and preferably should be less than one-half the width.

Minimum recommended width for joints is 1/16 inch. Maximum recommended depth is 1/2 inch for joints greater than 1 inch. Sealant beds deeper than 1/2 inch are not only too deep for good performance, but too slow to cure. Deeper joints should be built up or packed to within 1/2 inch of the surface.

## Three Elastic Boat Paints

—super products, super expensive.

- This paint will stretch with surface movement, and keep water out. Brochure "Liquid Seaprene" from: H. A. Calahan, Inc. 859 Mamaroneck Avenue Mamaroneck, N. Y. 10543
- 10 mil thick epoxy sealer, can be applied to damp surface, eliminates need for fiberglass. Fact sheet: "Gluvit" from: Travaco Laboratories 345 Eastern Avenue Chelsea, Mass. 02150
- Several types plastic coating, caulks, putties Brochure "Sav-Cote" from: Savcote of California 5409 West Adams Boulevard Los Angeles, CA 90016

## Plastics

Plastic sheets, thermopresses, rods, tubes for model making Catalog from:

Cope Plastics  
1111 West Delmar Avenue  
Godfrey, Ill. 62035

Glass reinforced thermoplastic sheets (Azdel) that can be formed on conventional metal stamping equipment Fact sheet from:

Gary Wagerson  
G. R. T. L. Co.  
No. 1 Gateway Center  
Pittsburgh, PA 15222

Acrylic Plastic sheet, resistant to ultraviolet, can be adhered with heat and pressure alone Technical data from:

Rohm & Haas Co.  
Independence Mall West  
Philadelphia, PA 19015

Teflon, plexiglas, fiberglass, mylar, vinyl, foam guns, etc. A complete catalog of plastic materials and prices.

from:  
Plasticraft, Inc.  
2800 North Speer  
Denver, Colo. 80211

Factory seconds of clear acrylic; complete line of plastics. Abe makes deals.

from:  
Abe Schuster Fiberglass  
6211 Telegraph Avenue  
Oakland, CA 94609

## Tadlar-coated Fiberglass Panels

from:  
Ornyte Fiberglass Panels  
711 Olympic Blvd.  
Santa Monica, CA

**Cement**—See also "Concrete Boatbuilding, Its Techniques and its Future," p. 24, and "Concrete Manuals," p. 31.

### Ferro Cement

Boats are being built on the West Coast of 3/4" thick ferro cement, often without forms. Pier Luigi Nervi has used the process extensively (for buildings) in Italy, and has encouraged fabricating boats by the same technique. It's cheap, strong, sounds relatively easy and some experiments will soon be taking place trying f.c. for domes and free-form buildings.

Good ferro cement information sources:

Ferro Cement Handbooks \$5-7

from:  
Saga Technical Associates  
P.O. Box 733, Terminal Q  
Toronto, Ontario, Canada

Ferro Cement furniture  
September 1968 Popular Science

Special f.c. reprint \$1.00  
from:  
National Fisherman  
22 Main Street  
Camden, Maine 04843



### Stack Sacks

Between adobe bricks and formed concrete walls is this other way. You take gunny sack halves, sew them into narrow bags, fill them with sand and some concrete, stack the dry bags up like bricks, pound re-bar down through the bags, frame doorways and such with re-bar, then wet the whole wall with a hose or a rainstorm, let cure, put on the roof (maybe with wet-concrete-dipped gunny sacks for shingles). Trowel on wet concrete for a smooth wall if you want it.

According to Holly Baer, who told us, the main source of information is:

Dicker Stack Sack International  
2600 Fairmont Street  
Dallas, Texas 75201

They are getting a patent on the device that turns out filled bags. Apparently local franchises can deliver an order of stack sacks to your door. Some people dip them in water, then place them wet.

### Dry Pour Concretek

Syntercrete is a new process where concrete is mixed in forms while dry, water added later. Result is good mold definition and high strength, due to low amount of water. Information from:

Syntercrete Corporation  
1300 Sansome Street  
San Francisco, CA 94111

## Membranes

Weather proof mylar, with ultraviolet resistants. Said to last two to five years outside exposure. About 19¢ per square foot.

from:  
Sears farm catalog (see p. 89)

"Spooky Mylar"—aluminized on one surface. If used as a window you see your reflection and at the same time the trees outside. Not ultraviolet resistant.

from:  
Transparent Products Corp.  
P. O. Box 15924  
Los Angeles, CA 90015  
Attn.: A. Robert Suba

### Clear Vinyl

About 6¢ / sq. ft.

from:  
Wards Farm Catalog  
(Nearest Wards Branch)

### Brochure "Dial-A-Spec Coated Fabrics"

from:  
Flexifirm Products  
2300 North Chico Avenue  
El Monte, CA 91733

Coated fabrics (ripstop nylon, vinyl coated fiberglass, silicone rubber coated dacron, etc.)

### Brochure "Coated Fabrics for Industry"

from:  
3M Company  
Film & Allied Products Division  
1601 South Shamrock Avenue  
Monrovia, CA 91016

### Coated Nylon Fabrics

Brochures "Protective Cover Fabrics" and "Engineered Fabrics for Industry"

from:  
West Point Pepperell  
Industrial Fabrics Division  
111 West 40th Street  
New York, N. Y. 10018

Parachutes: 24 ft. diameter canopies, white and in good condition. \$22.50 plus postage and tax

from:  
Security Parachute Co.  
P. O. Box 3096  
San Leandro, CA 94578

## Tapes for Dome Seams

Fab-Dek: 35 mil Hypalon impregnated with neoprene 3" wide roll, 11¢ per lin. ft. Adhesive \$4.50 per gallon. F. O. B. plant.

from:  
Miracle Adhesive Corp.  
27279 Industrial Blvd.  
Hayward, CA 94545  
or  
250 Pettit Avenue  
Bellmore, L. I., N. Y. 11710

Fiberglass tape with isophthalic resin.

Brochure from:

TAP  
1710 E. 12th Street  
Oakland, CA 94606

## Sundry Materials

FAB-DEK® is a 35 mil ONE SHEET ROOFING of HYPALON on an asbestos felt impregnated with Neoprene.

IT IS, WATERPROOF  
FIRE RESISTANT  
MILDEW RESISTANT  
WEATHER RESISTANT

EASY TO APPLY  
LIGHT IN WEIGHT  
LABOR SAVING  
QUICKLY INSTALLED  
Guaranteed to Bridge Small Cracks

Over 100 various pressure-sensitive tapes. Brochure "Tapes for Industry"

from:  
3M Company  
320 Shaw Avenue  
South San Francisco, CA

### Insurance rating on ferro cement—

The bulk of the test data set forth below was extracted from a report prepared by Lloyd's Register of Shipping who have given classification 100 A.1. - their highest - to a vessel with a Seacrete (ferro-cement) hull, provided that in all respects, e.g. superstructure, engine installation, electricals, etc., the construction complies with their rules. (Lloyd's letter of confirmation—7/12/65.)

WINDBOATS LTD  
Shipbuilders & Marine Engineers  
WROTHAM, NORWICH, NORFOLK. NOR 03 2

### NOTES IN REGARD TO THE PHYSICAL PROPERTIES OF SEACRETE

#### PROPERTIES— (a) DENSITY

151 lbs/cubic foot. (Mahogany 36 lbs/cu. ft.; reinforced plastic 100 lbs/cu. ft.)

#### (b) ULTIMATE STRESS, TENSILE

(1) Tensile bending stress on panels 48" x 12" x 7/8" loaded at centre point:

Stress to crack	1900 lbs. sq. in.
At yielding	3600 lbs. sq. in.
At ultimate	5340 lbs. sq. in.

(11) Tensile stress:

Stress to crack	1300 lbs. sq. in.
Stress to break	1690 lbs. sq. in.

#### (c) ULTIMATE STRESS, COMPRESSION

Compression tests on sample cubes 6" x 6" x 6"

Maturing time 7 days 14 days 28 days

Failing load (tons)	116	135.5	196.5
Ultimate stress (lbs. sq. in.)	7217.3	8742.2	12225

## Miscellaneous

### Skylights

Clear or opaque, these acrylic skylights are reasonably priced if you buy just the plastic part without the frame. A 30" circular bubble is about \$20. SLOPED CONDENSATION GUTTER EXTRUDED VINYL GASKET SLOTTED TO ALLOW DRAINAGE TO ROOF

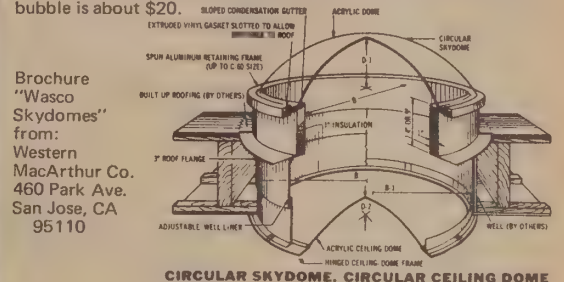

Brochure "Wasco Skydomes" from:  
Western MacArthur Co.  
460 Park Ave.  
San Jose, CA 95110

### CIRCULAR SKYDOME, CIRCULAR CEILING DOME

### Best Plywood for Domes

Durably flat panel siding is exterior Douglas Fir plywood with phenolic resin-fiber surface, designed for severe weather exposure. Guaranteed against delamination for life of building.

Brochure from:  
U. S. Plywood Corp.  
777 Third Avenue  
New York, N. Y. 10017

or yellow pages for nearest dealer.

### Energy Absorbing Material

Polymeric rubber foam for damping sound and vibes

Brochure from:  
Norton research Corp.  
70 Memorial Drive  
Cambridge, Mass 02142

### Plastic Hinges

This tough hinge was flexed 1,000,000 times without breaking. Comes in rolls, about 30¢ per foot.

Fact sheet "Polyhinge" from:  
Stokes Molded Products  
75 Taylor Street  
Trenton, N. J. 08604



### Lock and Key Extrusion

A simple way to install galls or plastic windows in wood or metal panels.

Information from:

Alasco Rubber & Plastics Corp.  
839 Malcolm Road  
Burlingame, CA

### Laminite Cardboard

Unbelievably tough, fire-retardant, and light. Samples from:

Laminite Division  
Tri-Wall Containers, Inc.  
One Dupont Street  
Plainview, N. Y. 11803



## Ashley Thermostatic Wood Burning Circulator

This is a unique wood burning stove. It has a thermostat which controls air intake, thereby burns much less wood than an ordinary stove. Will go up to 12 hours without refueling. In cold climates people build just one fire a season, adding wood 2-3 times a day. It takes any type wood, up to two feet long.

One kept us warm when we lived in a chicken coop with cold concrete floors and now an Ashley is the only heat we have in a 900 sq. ft. house with high ceilings.

The firebox is airtight and there is a lever on the air intake you can set for the desired temperature. A temperature-sensitive device (bi-metal helix coil) then automatically regulates air flow to keep heat at the setting you've chosen.

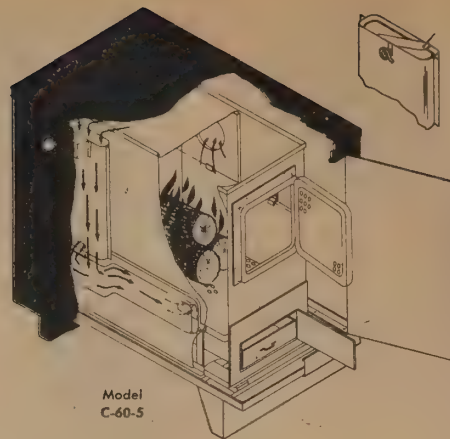
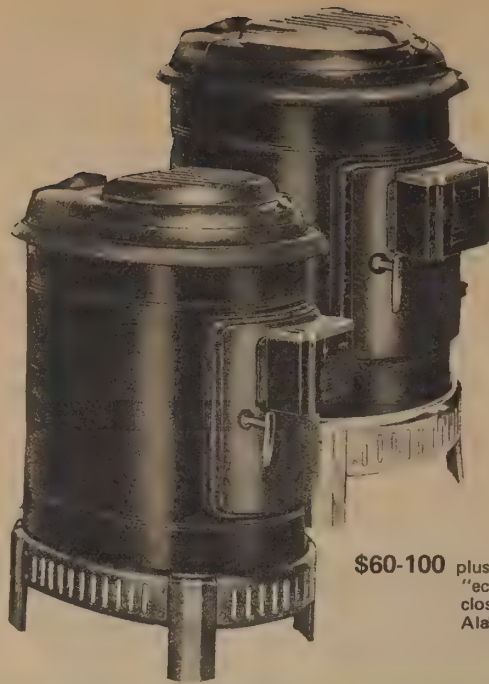

Firebox and ash doors are airtight. The only air admitted to primary combustion area of firebox enters at top (2) of downdraft stack, then is distributed evenly through air intake manifold (3) to bottom of firebox along its entire length, assuring even, more complete combustion, and eliminating hot spots (which also assures longer life of all firebox components). Thermostatic control (1) consists of damper (A) in top of downdraft stack actuated by a bi-metal helix coil (B) which is temperature sensitive, opening and closing damper just enough to admit precisely the amount of combustion air necessary to maintain the level of comfort you have selected.

Please note that the Ashley introduces combustion air at FRONT of firebox (not at one end) so flow to flue is ACROSS the fire — not across one end or corner of it, as in other heaters. This promotes even, efficient burning along entire length of firebox.

\$60-100 plus shipping for different sizes of "economy line" (Prices lower the closer you are to the factory in Alabama)

from Ashley Automatic Heater Co. P.O. Box 730 Sheffield, Ala. 35660

or Ashley Spark Distributors, Inc. 710 N.W. 14th Ave. Portland, Ore. 97209 or WHOLE EARTH CATALOG

## New Sources of Energy

Well, they aren't new sources; they're the oldest: sun, wind, earth heat (geothermal). But OK, to us they're new, and indeed they're exciting. The prospect of truly self-contained habitable energy systems is romantic country. There you are with your friends on your hill putting sun and wind through useful changes that are not only apparent to you but an integral part of your living.

Michael Rosenthal first tipped us to this remarkable set of U.N. documents which arose from a conference in Rome in 1961. If you're deeply into solar or wind energy there's lots of stuff here unfindable elsewhere. Japanese solar pillows—simple elegant water heaters up on the roofs, thoroughly described in Vol. 5. Traditional Dutch drainage windmills with suggested adaptations for other early-technology applications in Vol. 7. And so on. A trove.

[Suggested by Michael Rosenthal]

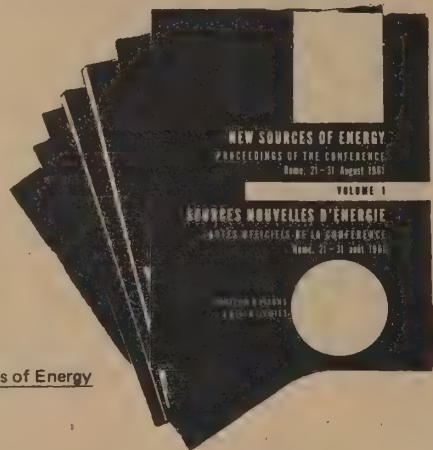

Solar water heaters in Japan 8/68 Tanlebia

### Proceedings of the United Nations Conference on New Sources of Energy

Vol. 1	General Sessions	—	\$2.50
Vol. 2	Geothermal I	—	\$5.00
Vol. 3	Geothermal II	—	\$5.50
Vol. 4	Solar Energy I	—	\$7.50
Vol. 5	Solar Energy II	—	\$4.50
Vol. 6	Solar Energy III	—	\$5.00
Vol. 7	Wind Power	—	\$3.50

from: Sales Section, United Nations, New York, New York

## ★ Windmills

Even though the Sears Catalog no longer lists them, windmills are still manufactured, and still the cheapest pumping power available. Aermotor claims to have 800,000 windmills in operation, and will also supply basic information on submersibles, jets, shallow well pumps and others. Dempster Industries also makes windmills, as well as hand-operated cistern pumps.

[Suggested by Steve Durkee]

Prices are about the same for both companies:

Size	Price	F.O.B. shipping points
6'	\$215.00	
8'	295.00	
10'	465.00	

Free literature from:  
Aermotor  
2500 W. Roosevelt Road  
Chicago, Ill. 60608

Dempster Industries  
Beatrice, Nebraska 68310

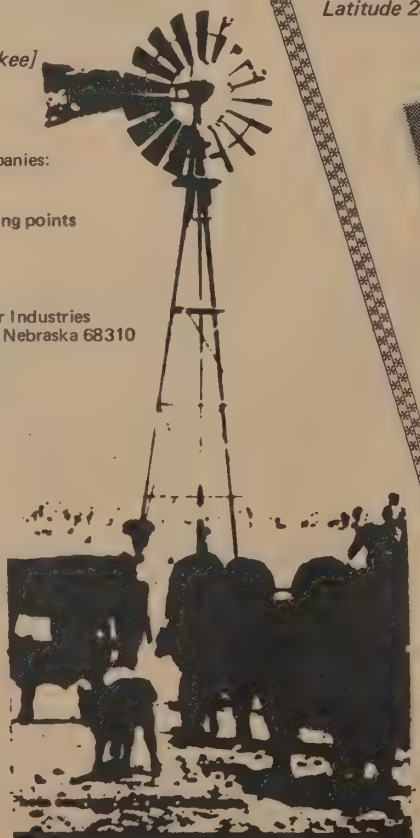

## ★ Sager Weathercaster

Nifty item. It has a dial and some tables of numbers. If you know your present weather, wind direction, and barometer reading, you can run the information easily through the weathercaster and get a reliable local prediction for the next 24 hours or so as to weather, wind direction, and wind velocity. Good anywhere north of Latitude 25° North.

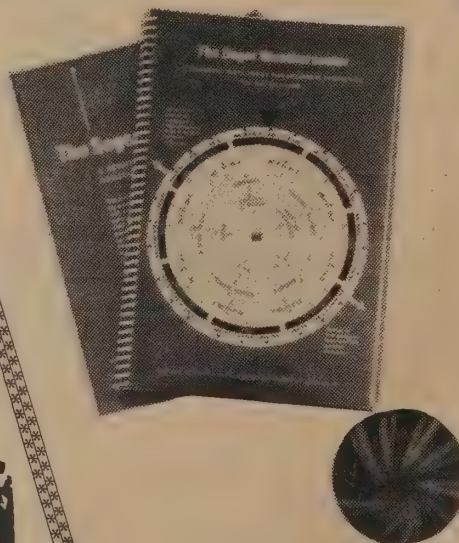

The Sager Weathercaster  
1942 . . . 1969; 25 pp.

\$5.95 postpaid

from:  
October House, Inc.  
55 West 13th Street  
New York, N. Y. 10011

or WHOLE EARTH CATALOG

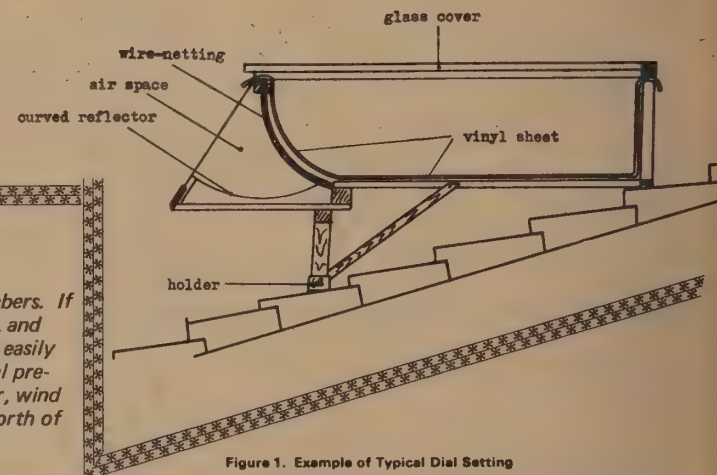
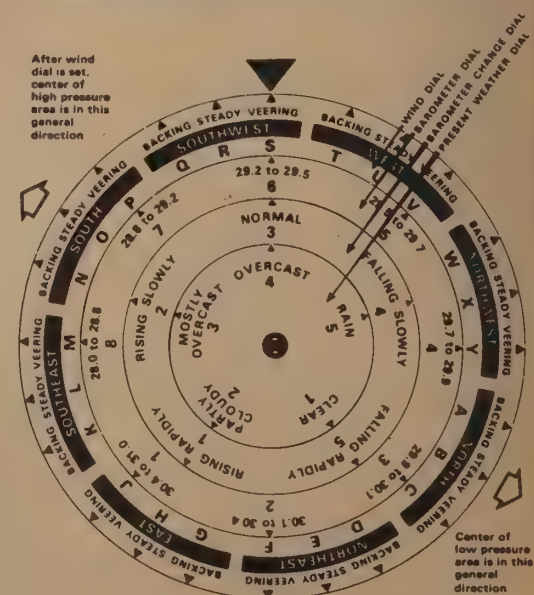

Figure 1. Example of Typical Dial Setting

This example is based on the following conditions: Wind is from southwest and veering. Barometer reading 29.45. The barometer is considered normal. The present weather is overcast. The Code Number from this example is S634. The forecast is: RAIN OR SNOWFALL FOLLOWED BY IMPROVEMENT (WITHIN 12 HOURS) AND BECOMING COOLER; STRONG SOUTHWEST OR WEST WINDS BECOMING STRONG WEST OR NORTHWEST.



After wind dial is set, center of high pressure area is in this general direction

Center of low pressure area is in this general direction

Meteorology and weather predictions by Raymond M. Sager, staff meteorologist of the New York Daily News since 1937

# Previously listed in Shelter and Land Use and still beloved:

## The Dymaxion World of Buckminster Fuller

The most graphic of Fuller's books (it's about his work, by Robert Marks). Consequently it is the most directly useful if you are picking up on specific projects of his such as domes, geometry, cars, demographic maps and charts, etc.



**The Dymaxion World of Buckminster Fuller**  
Robert W. Marks  
1960; 232 pp.

**\$12.50** postpaid

from:  
Southern Ill. Univ. Press  
6000 West Grand  
Carbondale, Illinois 62903

or **WHOLE EARTH CATALOG**

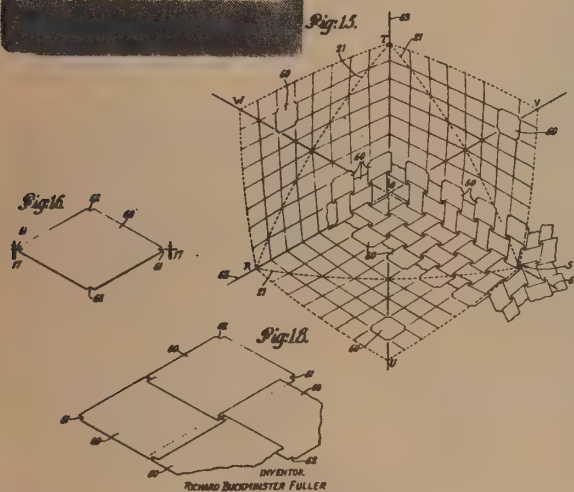

## The Japanese House

Without getting all sentimental and exotic we're still going to agree that Japanese make better houses than anybody else (they also have the fastest growing economy in the world, but that's another story — or is it?). If you're going to build your own house and don't mind some inspiration on the subject, this book was laboriously made for you. It's a great big Christmas present of a book full of yummy photos and diagrams and details of technique, all of which seems right within reach: I-can-do-it. Nice cure for nothing-can-be-done-because-it's-too-damned-big industrial blues.

[Suggested by Zen Mountain Center]

**\$27.50** may choke you up, in which case get Japanese Homes and their Surroundings, \$2.50 from Dover Publications—straight information on how to hand-make a lovable environment.

**The Japanese House—  
A Tradition for  
Contemporary Architecture**  
Heinrich Engel  
1964; 495 pp.

**\$27.50** postpaid

from:  
Charles E. Tuttle Co., Inc.  
Rutland, Vermont 05701

or **WHOLE EARTH CATALOG**

**Japanese Homes and  
Their Surroundings**

Edward S. Morse  
1886, 1961; 372 pp.

**\$2.50** postpaid

from:  
**WHOLE EARTH CATALOG**

**\$2.70** postpaid

from:  
Dover Publications, Inc.  
180 Varick Street  
New York, N. Y. 10014



FIG. 167 — KITCHEN IN OLD FARMHOUSE AT KABUTAYAMA.

## Fuller Sun Dome

The most readily available plans for a geodesic dome. The \$5 includes construction license. Designed for swimming pool covers, dome plans specify wood strips and cheap polyethylene skin. However, you can modify to build domes of other materials, such as plywood, parachutes, or car tops. A simple system: two triangles make the dome; can be used up to about 35' diameter.

[Suggested by Ken Babbs.]

**Geodesic Sun Dome**  
1966

**\$5.00** postpaid

from:  
Sun Dome  
Popular Science Monthly  
355 Lexington Avenue  
New York, N. Y. 10017



## The Elements Rage

Every so often larger than normal pieces of cosmic energy lean on human affairs. The community dies, and is reborn, and ever after tells what the face of maelstrom looked like. Here are hair-raising photographs, intrepid accounts, hammerhead tragedies, and a seven-page scale of the energy gradient from a baseball homerun to the mass energy of the M31 galaxy. Classic.

[Suggested by Jordan Belson]

**The Elements Rage**  
Frank W. Lane  
1965; 346 pp.

**\$7.50** postpaid

from:  
Chilton Books  
401 Walnut Street  
Philadelphia, Pa. 19106

or **WHOLE EARTH CATALOG**



A tornado, like thunder, is heard many miles away. As it approaches, there is a peculiar whistling sound that rapidly changes to an intense roar, reaching a deafening crescendo as it strikes. The screeching of the whirling winds is then so loud that the noises caused by the fall of wrecked buildings, the crashing of trees, and the destruction of other objects is seldom heard.

## Wild Foods

Euell Gibbons once was challenged to gather a lunch of wild foods from Central Park, N. Y. C. After a few hours of foraging, a trip to the challenger's apartment, some washing and preparation, Gibbons served up a large delicious lunch that all the neighbors came to sample.

Gibbons has been gathering wild foods for years and has written three books: *Stalking the Wild Asparagus (foods from land)*; *Stalking the Blue-Eyed Scallop (sea-foods)*; and *Stalking the Healthful Herbs*.

Nutritious wild edibles are all around us and Gibbons tells us what they look like, where to hunt, and gourmet recipes for preparation. Wild rice, cattails, fairy spuds, watercress, groundnuts. Scallops, seaweeds, clams, kelp soup. Comfrey, horehound, wild ginseng.

**Stalking the Healthful Herbs**  
Euell Gibbons  
1966; 303 pp.

**\$7.50** postpaid

**Stalking the Wild Asparagus**  
Euell Gibbons  
1962; 303 pp.

**\$7.95** postpaid

**Stalking the Blue-Eyed Scallop**  
Euell Gibbons  
1964; 303 pp.

**\$7.95** postpaid

all from:  
David McKay Co., Inc.  
750 Third Avenue  
New York, N. Y. 10017

or **WHOLE EARTH CATALOG**

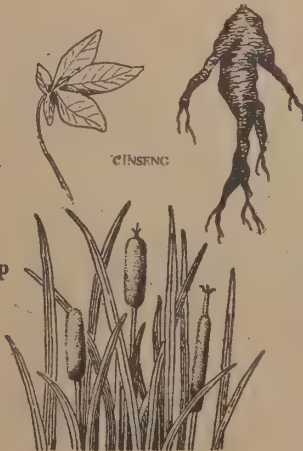

## Glue-nailed Roof Trusses

A truss can be made of relatively small pieces of wood, is light, cheap and therefore a more economical means of spanning distances than a solid wooden beam. Complete clear plans of 14 different types of trusses are available, 50¢ each. Also, publications on various building techniques, and a set of circulars, 15¢ each, on subjects such as *Selecting Lumber, Chimneys and Fireplaces, Plumbing, etc.*

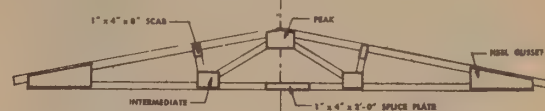

Brochure on publications  
free

from:  
Small Homes Council-Building  
Research Council  
University of Illinois  
Urbana, Illinois

## The National Fisherman

A monthly newspaper from Maine on fishing, boat building, sailing, ocean pollution and sea news in general. They are largely responsible for the current wave of interest in ferro cement, as they were first to give widespread U. S. publicity to the low-cost technique. Lately, each issue has had something new on f.c.

[Suggested by Paul Wingate]

## The National Fisherman

**\$4.00** for one year

from:  
22 Main Street  
Camden, Maine 04843

## Electricity From the Wind

This is the only commercially available wind electric generator we know of. Sounds and looks good. Has anyone used one?

**\$365.00** F. O. B. Sioux City, Iowa

from:  
Dyna Technology, Inc.  
P. O. Box 3263  
Sioux City, Iowa

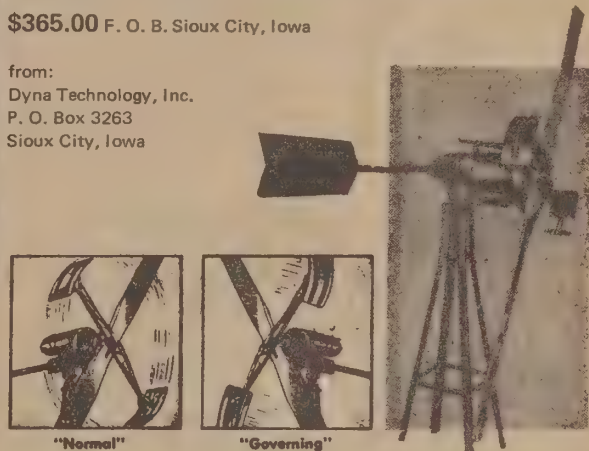

## Solar Stills

Horace McCracken makes solar stills that purify seawater, hard or brackish water using heat from the sun.

It consists of one or more shallow, insulated, glass-covered pans. A feed inlet admits water into one end of each pan, while an outlet tube at the other end maintains a shallow water level, and permits some overflow each night to flush out salts. Sunlight passes through the glass cover and warms the water in the pan. Vapor rises, condenses on the glass cover, and runs down into a collection trough.

## PRICE LIST

### Solar Stills

Model No.	Production Capacity in Gallons per Week	Outside dimensions: 5 1/2" high by 29" by length:	Price, complete ready to operate, F. O. B. S. D.
1	1	15	\$ 11.50
3-1/2	3-1/2	32	27.50
5	5	46	37.50
7	7	62	47.50
10	10	84	60.00
15	15	118	80.00
20	20	168	115.00

Note: Quantities larger than 3 gallons per day may be obtained by connecting smaller units together in series or parallel. For installations of more than 10 gallons per day, kindly request quotation.

# Industry and Craft

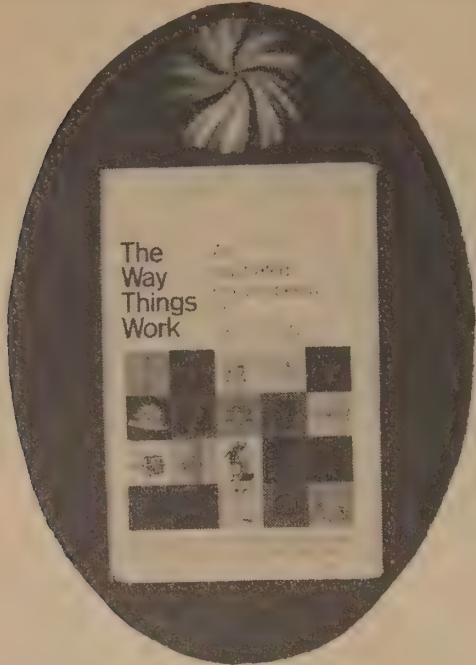

## The Way Things Work

The Way Things Work  
1967; 590 pp.  
\$8.95 postpaid

from:  
Simon & Schuster  
630 Fifth Avenue  
New York, N.Y. 10020

or WHOLE EARTH CATALOG

Best book for the bathroom we've seen. Nibble your way to knowledge of technology. Each two pages of the book is a bunch of text and a bunch of diagrams on all the big and little gadgets and processes you can think of, ball-point pens to data-processing. If you develop time travel, it might be interesting to take this book back to the sixteenth century and leave it under some European's pillow. (Now think about contact with alien civilizations.)

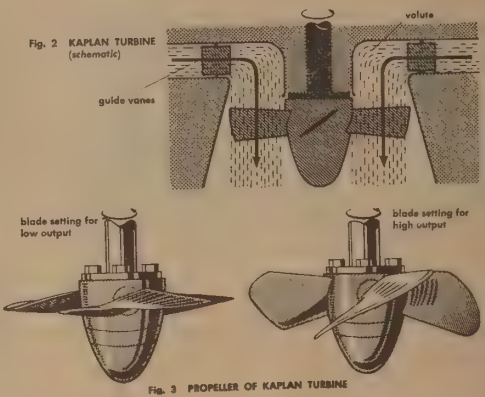
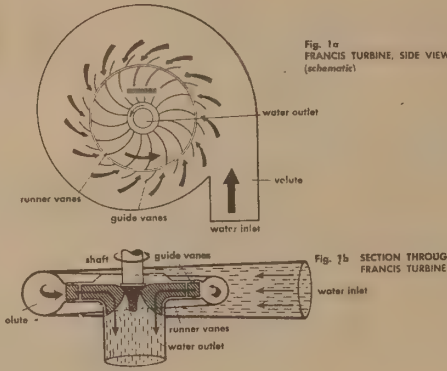
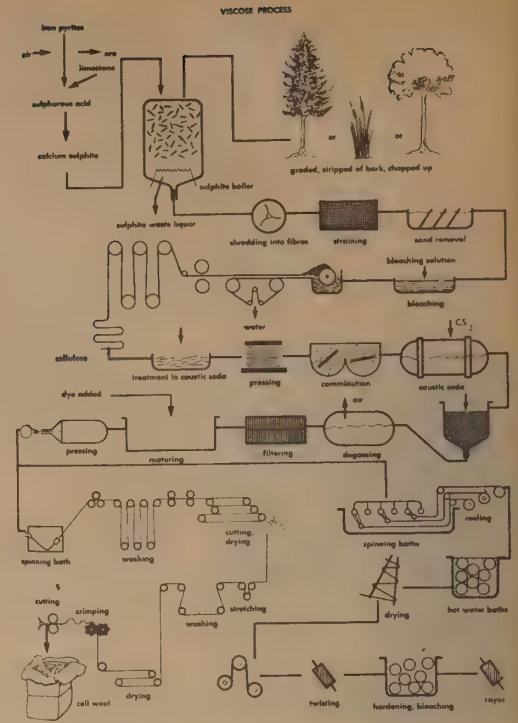
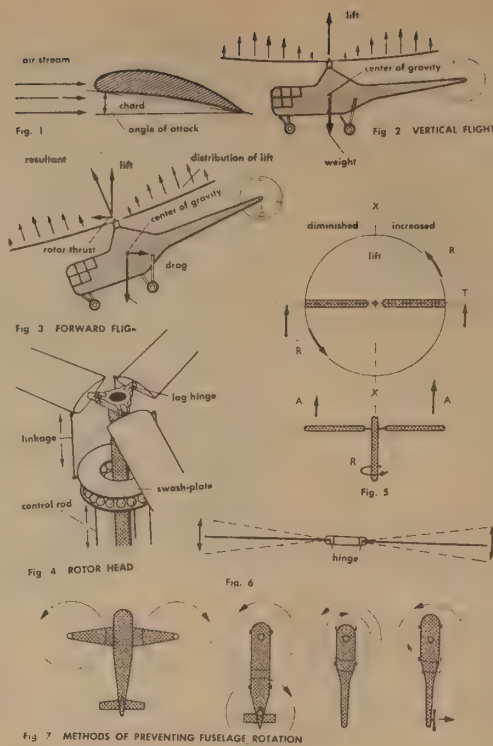

## Introduction to Engineering Design

Out of a whole section of books on design in the Engineering Library at Stanford, this book looked far the best. Recently Steve Baer (dome and solar designer) came across it on our editing tables, sat down and paged, then got up and hurriedly wrote a letter to a friend about the book and its author. I asked Steve to pick out some useful quotes and pictures and he wouldn't. "Look anywhere you open it," he advised, then ordered a copy.

Contents of the book include: The Engineering Problem Situation, Design Project Organization, Information and the Need Analysis, Identification of the Problems, Information Sources, Synthesis of Alternatives, Estimation and Order-of-Magnitude Analysis, Engineering and Money, Preliminary Design, Engineering Problem Modeling, The Iconic Model, Conceptual Representation, Expansion of the Criterion Function, Checking in Engineering Design, Optimization, etc., etc.



Fig. 7.4 Possible water channel sections. Water supply project for mountain cabin.

### WATER SUPPLY FOR MOUNTAIN CAMP

For another simple example, let us estimate how we would bring water from a running stream into a tank (let's say a 50-gallon gravity tank) to supply water for a vacation cabin in the woods. A natural supply point is 100 ft away upstream, guaranteeing among other things a clean, continuous water supply. Our problem is transport. Shall we use pipe, an open rock-lined channel in the ground, or a wooden flume or trough? See Figure 7.4.

As we think about this, we discard the open channel in the ground as too easily contaminated. The pipe could be laid on the ground; and the wood flumes could be suspended from tree trunks and possibly covered as shown by the dashed "board" in the illustration. Thus, we have two reasonable ways of doing this job; the questions now concern cost and convenience.

Next we check the sizes needed. If we wanted the 50-gal. tank filled in 15 min, we would need a flow of about 4 gal./min. This is a stream of water about as big as a person's finger when the water is flowing two feet per second, as shown by the equation in the footnote† deriving the cross-sectional area, A, of the stream.

This area would require a pipe one inch in diameter. If we were using the wood "vee" channels, we would need two boards each about three inches wide to avoid splashing over, or one-half board-foot per running foot of channel (per foot of channel length). (A board-foot is one square foot of wood, one inch or less thick.)

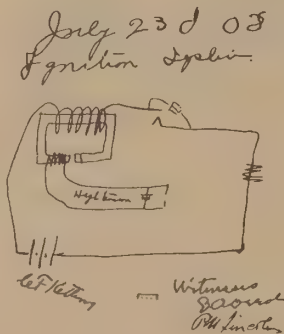

Fig. 6.2 A sketch that changed automobile ignition. (Courtesy General Motors Corp.)

Now we need to arrive at costs. The most convenient reference is a broad-coverage catalog (such as that of Sears, Roebuck), in which wood, metal, and other supplies can be found listed at retail prices. Of course, one can also phone the retail plumbing or lumber suppliers. In any case, we find

- Wood: 15¢-20¢ / board-foot in the sizes we need
- 1 in. iron pipe: 30¢ / ft
- ½ in. copper pipe: 58¢ / ft (One size smaller than iron pipe for the same flow rate.)

Assuming one-half board-foot for each running foot of wood channel, the comparisons are

- Wood: 10¢ / running foot, materials only
- Iron: 30¢ / running foot, materials only
- Copper: 60¢ / running foot, materials only

Since we would do the work ourselves, the cost of labor is disregarded, and it seems that wood should be our choice. On one final check though, we ask whether these are all the choices. Someone suggests plastic pipe, so we look that up: It is corrosion-resistant, flexible, easily connected, sanitary; it has a smooth interior; it could be in one piece and simply laid on the ground. It seems to be a natural choice. The price of ½-in. diameter plastic pipe is 10¢ / ft; 1-in. diameter is 16¢ / ft. Considering the labor needed with wood or iron pipe, or the cost of copper tubing, and the plastic's sanitary advantages, the plastic pipe (high-density polyethylene) is certainly the preferred choice.

Thus our final estimate is the use of this plastic tubing, probably ½-in. diameter at 10¢ / ft.

$$\begin{aligned} \dagger A &= Q/V \text{ (area = flow/velocity)} \\ \text{where} \\ Q &= 4 \text{ gal./min} = 1000 \text{ cu in./min} \text{ (1 gal. = 231 cu in.)} \\ V &= 2 \text{ ft/sec} = 24 \text{ in.}/(1/60 \text{ min}) = 1500 \text{ in./min} \\ A &= \frac{1000 \text{ cu in./min}}{1500 \text{ in./min}} = 2/3 \text{ sq. in.} \end{aligned}$$

## Introduction to Engineering Design

Thomas T. Woodson  
1966; 434 pp.  
\$9.95 postpaid

from:  
McGraw-Hill Book Company  
Princeton Road  
Hightstown, N.J. 08520  
Manchester Road  
Manchester, Missouri 63062  
8171 Redwood Highway  
Novato, Calif. 94947

or WHOLE EARTH CATALOG

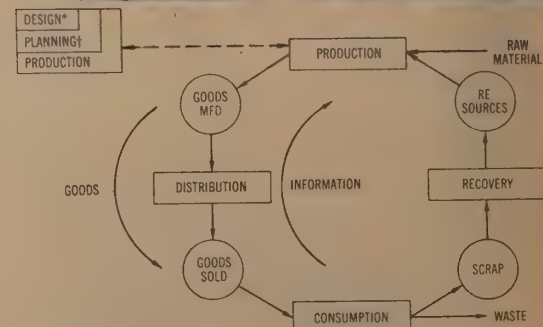

\*DESIGN is a part of PLANNING  
†PLANNING is a part of PRODUCTION

Fig. 3.7 The production-consumption cycle, showing the place of engineering design.

## Direct Use of the Sun's Energy

The best book on Solar Energy that I know of. Any curious and intelligent person can learn a great deal about our planet and ourselves by reading this book about ways of using sunlight. There are many numbers in the book but the math never goes beyond 8th grade arithmetic. The book is clear and simple whether talking about heating water—

For general domestic use of hot water for bathing and washing dishes a temperature of 135°F (57°C) is considered adequate and 20 gal per person per day is a reasonable consumption. In many sunny climates these requirements can be met with an insulated storage tank and solar radiation absorber which has an area of 0.75 ft<sup>2</sup> gal<sup>-1</sup> of hot water. A family of four would need a tank of 80 gal and a solar absorber of 60 ft<sup>2</sup>.

or photochemical reactions—

The photo dissociation of iodine (I<sub>2</sub>) molecules into atoms absorbs most of the visible light of the sun with a considerable amount of energy, but the iodine atoms recombine so fast that the energy cannot be retained. It is immediately evolved as heat during the exposure to light.

I read the book on a Greyhound bus in Texas two years ago and it has changed my life and my way of thinking.

[Reviewed by Steve Baer]



11. World wide distribution of solar energy in hundreds of hours per year. [Adapted with permission from Solar Energy, cover, 1, no. 1 (1957).]

## Direct Use of the Sun's Energy

Farrington Daniels  
1964; 374 pp.

\$8.50 postpaid

from:  
Yale University Press  
149 York Street  
New Haven, Conn. 06511

or WHOLE EARTH CATALOG

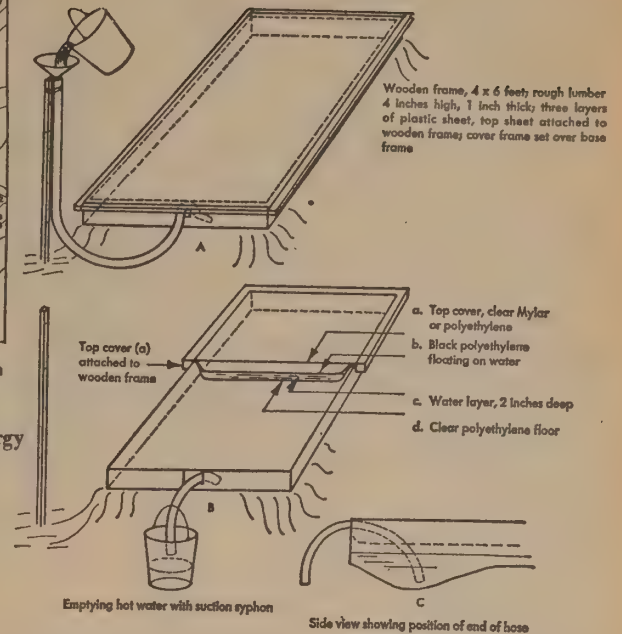

29. Inexpensive solar water heater. A. Filling with cold water. B. Emptying hot water with suction syphon. C. Side view, showing position of end of hose.

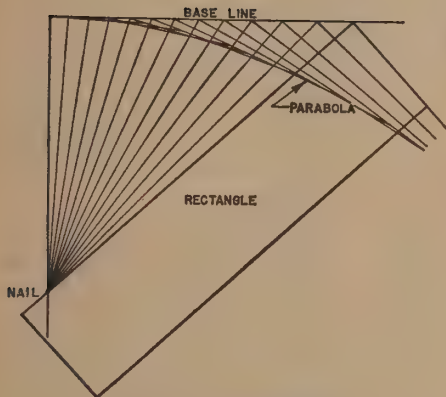
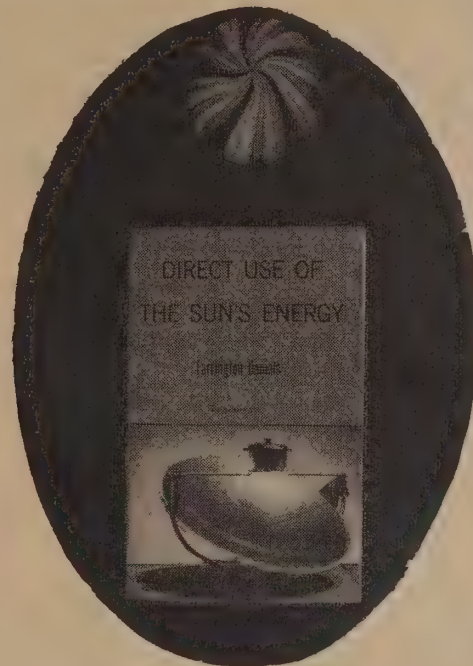

18. Method for drawing a parabola.

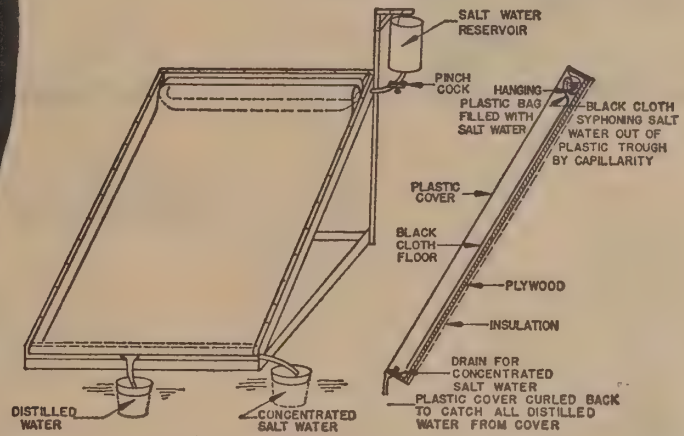

32. Tilted plastic still of simple construction.

## The Design of Design

It's superficially a book for design engineers, but should be useful to anyone engaged in the design of physical objects or strategies. Simple and basic. More advanced treatment of design techniques gets you into computers and very sophisticated decision making theory. The main trip is concentrated on getting your head straight so that design decisions of any sort can be made intelligently. There's a good bit of practical advice concealed in a slurry of English Humour. The only book of its type that we know of. Among the better points:

Concentration and then relaxation is the common pattern behind most creative thinking.

Beware of intrinsic impossibilities.

Beware of pseudo-technical words. [He means words like "sturdy," "big," "beautiful", etc.]

Define problems in figures or configurations.

Aim at continuity of energy.

He really gets to the center of the modern-technology-versus-New-Mexico-Funk argument:

If the design of a particular machine or production line is based on the way the process was originally done by hand, it is unlikely to be the final form. The feeding forward by mechanizing a style that was handy when only hands were available is doomed, in the long run, to be superseded by the feeding back of ideas and materials from the physical sciences. Beware of well-dressed arts and crafts.

[Reviewed by Jay Baldwin]

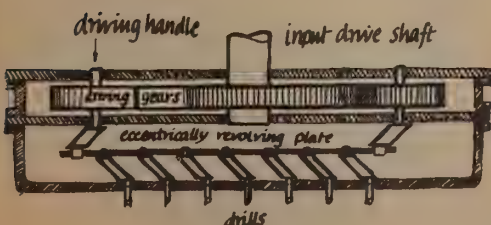

cart wheel

bicycle wheel

the Forth bridge

the Severn bridge

Suspension bridge designers thought at first that the major problem would be the load, and learned by spectacular experience that it was really the stability.

Invention	Inventor
Safety razor	Traveller in corks
Kodachrome films	Musician
Ballpoint pen	Sculptor
Automatic telephone	Undertaker
Parking meter	Journalist
Pneumatic tyre	Veterinary surgeon
Long-playing record	Television engineer

You feel that there must be some simpler solution. There is one. You could drive all the drills by one input shaft, using a total of three gears only and have quick replacement too. And the secret of discovering how to do it is to realize that all the complications you are in are due to your having made one part too simple. There is another way of rotating a shaft than by a gear. Put a handle on it (Fig. 7). A drill with a cranked handle is more complicated and expensive than the orthodox straight shank but its advantages are overwhelming. You can turn the handle by putting a bush on it and turning that. To stop the handles hitting each other you must arrange them to keep in step; easy enough: fasten all the bushes together by making them holes in one plate. How can we make this plate describe the proper path? Drive it by a couple of handles put in the other way round. As they must rotate the same way, put a gear between them. This gear can be on the input drive shaft.

To replace a drill, all you need to do is to remove the outer bearing plate, pull out the broken drill backwards, put in another, and replace the plate.

You are taken out to lunch and everyone is anxious to hear you tell them how a "few adjustments" or possibly "some electronics" will solve all the difficulties. You have to break it to them that everything is wrong in principle.



The Design of Design  
Gordon L. Glegg  
1969; 93 pp.

\$4.95 postpaid

from:  
Cambridge University Press  
32 East 57th Street  
New York, N. Y. 10022

or WHOLE EARTH CATALOG

Now when a steel pile is suddenly hit on its top, the bottom does not simultaneously go further into the ground. The force from the hammer is transmitted as a shock wave which travels down the length of the pile, finally giving the bottom end a kick. But more than this happens. A steel pile behaves like a long helical spring and vibrates longitudinally at its resonant frequency, until the side damping effect of the ground dissipates the residual energy, which it does very quickly.

The problem of making the tube an ally and not an enemy can be solved by utilizing this resonant frequency. If you apply a force that pushes and pulls on the top of the pile with the same frequency as the resonant one, you can silently feed in energy in a form which the pile can transmit to its bottom end. This has useful side effects as the vibration fluidizes the earth surrounding the pile and greatly reduces the frictional drag. The energy is tuned, focused and economized.

**New Scientist**

New Scientist is the best evidence we've seen that there are new scientists in the world, young, politically aware, irreverent, active. Every week here's yet another blue New Scientist (if you get behind reading, it's hopeless), full of actual news, critique, and gossip of the research world. The magazine is British, so you get perspective on U. S. accomplishments (flattery nonetheless), and report of worldwide activities unreported in most American journals. The Ariadne column is a gem.

[Suggested by Steve Baer]

Much depends on whether dormice have nightmares. ☐



New Scientist  
\$16.00 for one year (weekly)

from:  
New Scientist  
128 Long Avenue  
London W. C. 2

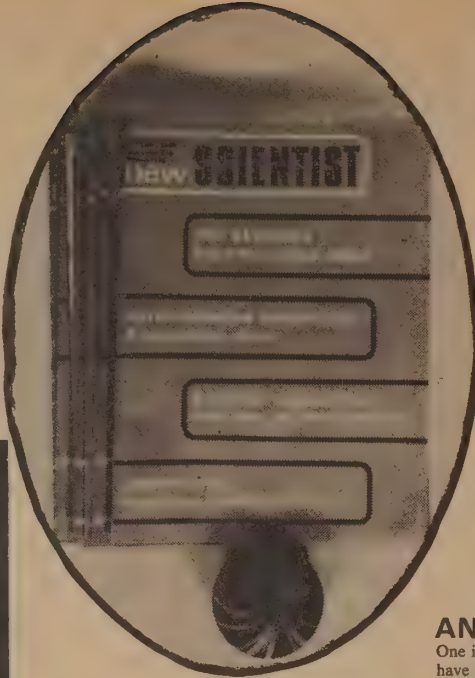

**At last—a pulsar that flashes**

**All the way with DNA**

**A crystal clear memory for many things**

Holography is bringing about a rapid and spectacular revolution in applied optics. Three researchers at Bell Telephone Laboratories have now demonstrated that they can store up to 1000 holograms simultaneously in the small crystal of lithium niobate illustrated here. Their new optical memory has much greater efficiency than a conventional holographic plate, as well as much greater storage capacity.

**A protein from way-back-when**

A new structural determination of a protein—which has turned out to be one of the most primitive ever examined—should help to chart the early course of evolution. It also supports a new hypothesis to explain how living mechanisms have increased in complexity.

**ANOTHER HAZARD OF SMOKING**

One in five of unsuccessful pregnancies in women who smoke regularly might have been successful if the mother did not smoke

**Scientific American**

Good old Scientific American.

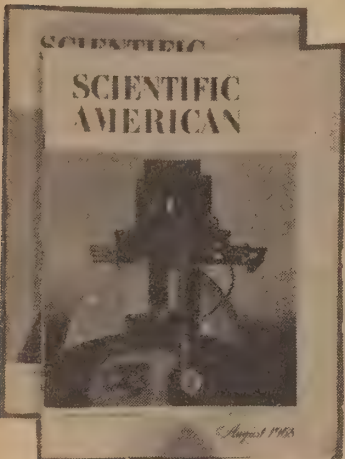

**How to blow soap bubbles that last for months or even years**

“One of the two solutions consists essentially of Kuehner's dibromostereate soap. The other one is a solution of polyvinyl alcohol, water and glycerin. Bromine is an extremely hazardous substance before it has reacted with the acid, and compounding these mixtures calls for controls that are not available in the home. For these reasons amateurs should not attempt to make double-bubble solution. It can be bought from the Techno Scientific Supply Company, Inc., P.O. Box 191, Baldwin, N.Y. 11510. The solution costs \$4 a pint, a quantity sufficient to blow thousands of bubbles.

Scientific American  
\$8.00 for one year (monthly)

from:  
Scientific American  
415 Madison Avenue  
New York, N.Y. 10017  
or most newsstands.

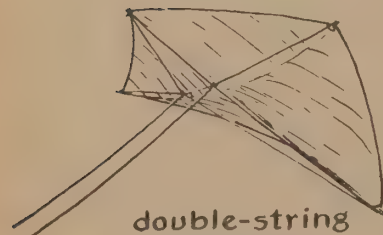

**42**

**Pollution by Fertilizer**

Man's injection of excess nitrogen into the biosphere not only is seriously polluting rivers and lakes but also has greatly increased the frequency of a rare form of poisoning among both humans and domestic animals. Reporting at a symposium on pollution during the annual meeting of the American Association for the Advancement of Science, Barry Commoner of Washington University noted these results of the rise in nitrogen production in the U.S. during the past 25 years. Nitrogen from sewage, a reflection of the nation's population growth, has increased no more than 70 percent in that time, but the oxides of nitrogen produced by power plant fumes and automobile exhaust have increased by 300 percent and the use of nitrogen fertilizers by 1,400 percent. The last two processes add some 10 million tons of nitrogen compounds to the environment each year, more nitrogen than is cycled annually within the U.S. by all the processes of nature combined.

**More Brain, Better Brain?**

Animals with more than the normal amount of brain tissue may learn more quickly than normal animals.



**Murder at Thank God Bay**

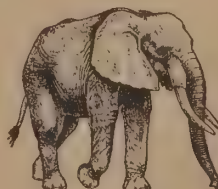

PROBOSCIDEA

**Product Engineering**

Roy Sebern pointed out the main satisfaction of reading Product Engineering: in the usual magazines such as Popular Science, everything has the tone of “I-wish-they’d make . . .”; whereas in Product Engineering it’s “We are making . . .” The magazine has good reporting and excellent editing. Increasingly it is going beyond the question of how to make stuff into why make stuff. Departments include Research & Technology, Mechanical Design & Power Transmission, Hydraulic/Pneumatic Power & Control, Materials & Manufacturing, Product Planning & Management, and the Engineer & His Profession.

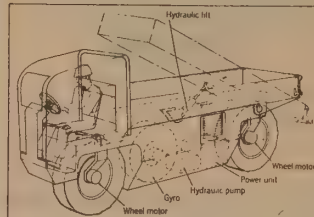

Payload to 3000 lb. can be transported at speeds to 15 mph up 60% grades by newest gyro-stabilized trail truck just designed for the Forest Service.

A real revolution may be in the making in the textile industry. BASF of Germany is said by the American Chemical Society to be well along in development of a process that will “cast” fabrics directly from liquid monomers—no separate polymerization, fiber extrusion, spinning, or weaving. If the report is correct, much of today’s \$15-billion worth of fiber-production and textile-mill equipment could become obsolete almost overnight, and an entirely new type of plant, with entirely new equipment, will be needed.

Electronarcosis is gaining favor as an anesthetic system in the Soviet Union, and new equipment is being developed to do the job. A good deal of work is under way in this country, too, on electrical sleep-inducing systems, as a Neuroelectric Conference held at Stanford Research Institute only a few months ago clearly indicated. The Army Medical R & D Command, for instance, is sponsoring research at Marquette Univ. on inducing sleep by supplying gentle electric pulses to the brain through electrodes attached to the patient’s head. Tests on humans are scheduled for a year from now.

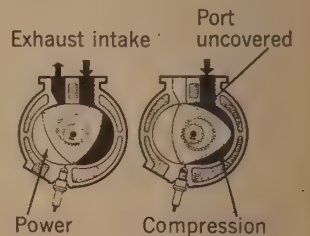

**Product Engineering**

\$15.00 for one year (biweekly)

from:  
Fulfillment Manager  
Product Engineering  
P. O. Box 430  
Hightstown  
N. J. 08520

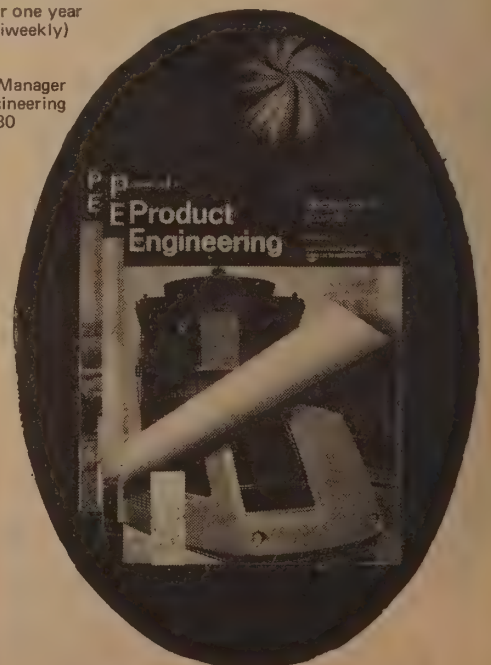

**Popular Science**

Of the three, Popular Science, Popular Mechanics, and Mechanics Illustrated, consistently the somewhat better is Popular Science. It's a good source for current applied science reporting and basement technology. Most of the tool sources we list advertise in the magazine.

[Suggested by J. Baldwin]

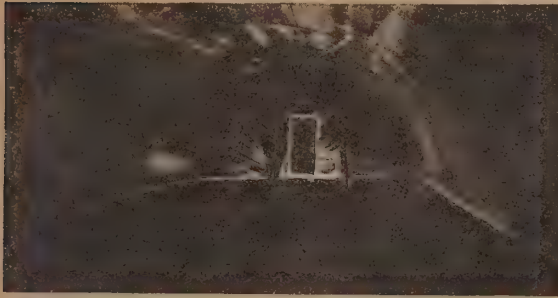

Spacious interior of house made from 40-by-100-foot polyethylene sheet has floor bigger than a tennis court. It's held up by fan beside door at rear.

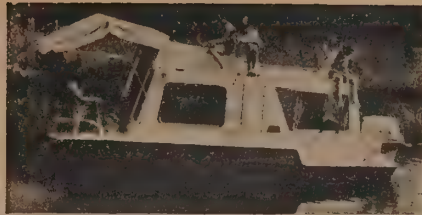

Hobo. All-fiberglass Mark III is lowest-priced houseboat at \$3,395. Sleeps four adults, two children. Designed for outboards up to 55 hp.; trailer available. Graham Products, Inglewood, Ont., Canada.

A single sheet of polyethylene film can be fashioned, in one afternoon, into a giant enclosure that makes all this possible. This plastic "roof" is supported only by air from a household exhaust fan. Sound expensive? It's actually the cheapest and simplest shelter you can erect. The one illustrated gives you a floor space of 27 by 85 feet—the maximum you can get from a 40-by-100-foot sheet. There's no footing to dig—the edges are merely taped to sausage-like sandbags. The only construction involved is framing up the fan and entrance door, as shown below. The total cost? Under \$60. For covering smaller areas, figure less than three cents a square foot.

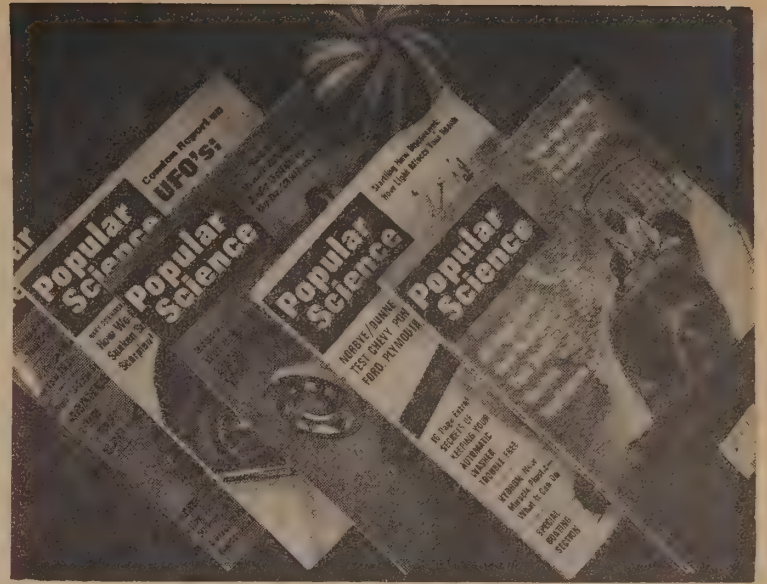

Popular Science from: Popular Science Subscription Department Boulder, Colo. 80302 \$5.00 /yr. (monthly)

**Popular Mechanics Projects**

On the other hand, Popular Mechanics offers a list of reprints of innumerable homey projects, priced 15¢ to a dollar per project.

[Suggested by Mu]

**Popular Mechanics Catalog of Publications and Projects**

free

from: Popular Mechanics Service Bureau, Dept. RF 575 Lexington Avenue New York, N. Y. 10022

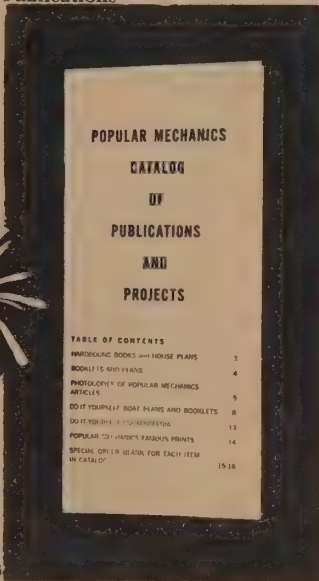

- X12 Alternator, getting to know it 3/63-174, \$1.05
- X14 Amplifier for your pocket 10/66-198, 45¢
- X15 Amplifier, guitar 11/57-160, 75¢
- X16 Antenna boosts FM reception 11/63-199, 15¢
- X17 Antenna, UHF yagi 6/59-144, 45¢
- X18 Antiques, turning reproductions into 7/66-116, 75¢
- X19 Aqua-sled 7/66-138, 30¢
- X20 Arbor press for small shop 7/53-189, 45¢
- X21 Arbors & trellises 4/51-188, 60¢
- X22 Arc welder 9&10/48-205,213, \$1.35

**Clearinghouse**

Its full name is "Clearinghouse for Federal Scientific and Technical Information," it's managed by the U.S. Department of Commerce, and it's quite a service. All current unclassified R&D (research and development) done for or by the Government is available through Clearinghouse; this amounts to 30,000 new documents each year. Specific accesses are: U.S. Government Research and Development Reports (December 1,000 new documents twice a month), \$22/year; Fast Announcement Service, for as many as 57 subject areas, delivered constantly, \$5/year; and Technical Translations, twice a month, \$12/year. These are indexes. Once you find what you want you order a paper copy (hard copy) for around \$3 or micro-film (microfiche) for around \$.65. The following examples of listings are from the Fast Announcement Service.

[Suggested by Jon Dieges]



Write for free information and order forms to: U.S. Department of Commerce Clearinghouse for Federal Scientific & Technical Information Springfield, Va. 22151

AD-677 116 -- A SOLAR-ILLUMINATED ALGAL PHOTOSYNTHETIC EXCHANGER, R. L. Miller et al., Martin Co., Denver, Colo., for the Air Force, June 68, 26p. . . . Describes a continuous culture system for studying the use of solar energy for algal growth and photosynthetic gas exchange.

.. ORDER: PB-180 051 -- TRITON CITY - A PROTOTYPE FLOATING COMMUNITY, Triton Foundation, Inc., Cambridge, Mass., for the Dept. of Housing and Urban Development, Nov. 68, 131p.

Fuller's floating city

AD-683 047 -- WHAT IS MEMORY THAT IT MAY HAVE HINDSIGHT AND FORESIGHT AS WELL, H. Von Foerster, Univ. of Illinois, Urbana, for the Air Force, Jan. 69, 61p. . . . Discusses the phenomenon of physiological memory from the viewpoint that memory is embedded into the totality of cognitive processes and considered as a computational operation rather than a storage and retrieval problem.

AD-681 752 -- A FIFTEEN-YEAR FORECAST OF INFORMATION-PROCESSING TECHNOLOGY, G. B. Bernstein, Naval Supply Systems Command, Washington, D. C., Jan. 69, 187p. . . . Uses SEER (System for Event Evaluation and Review), a technique that incorporates the consensus of participant experts, to produce a technological forecast of what is expected to occur in the information-processing industry.

PB-180 665 -- THE INFLUENCE OF DESIGN ON EXPOSED WOOD IN BUILDINGS OF THE PUGET SOUND AREA, E. W. Schein, USDA, Pacific Northwest Forest and Range Experiment Station, Portland, Ore., Sept. 68, 50p. . . . Identifies the best existing design solutions to exposure hazards.

AD-680 168 -- SPIRAL GENERATION OF BUILDING SHELLS: OR MILITARY CONSTRUCTION, A. N. Collishaw and R. D. Graham, Dept. of the Army, Ohio River Division Labs., Corps of Engineers, Cincinnati, Ohio Nov. 68, 30p. . . . Discusses immediate and potential applications of the spiral generation construction process to military construction. Included are permanent, semi-permanent, and temporary construction.

PB-182 401 -- BUILDING CLIMATOLOGY, PART IV: NOISE, National Swedish Institute for Building Research, Stockholm, 1968, 86p. . . . Annotated bibliography of literature dealing with the following aspects of noise: (1) subjective reactions to sound, noise, and vibration, (2) objective methods of registering sound and noise, (3) noise situations, (4) fighting noise (technical and legal steps to improve noise climate) and sound insulation, (5) acoustic planning, and (6) theory of sound propagation.

AD-678 571 -- TAN-O-QUIL-QM TREATMENT FOR FEATHERS AND DOWN, G. Cohen, U.S. Army Natick Labs., Natick, Mass., Aug. 68, 80p. . . . Describes a process for treatment of feathers and down that uses a tanning agent and a water repellent and is applicable to both landfowl and waterfowl feather filling materials. Feathers treated by the process have increased filling power that is durable to laundering, are free from dust, are exceptionally clean, and will not develop an odor even when wet.

AD-685 850 -- WATER SUPPLY IN COLD REGIONS, A. J. Alter, Cold Regions Research & Engineering Lab., Hanover, N. H., Jan. 69, 94p. . . . Discusses the influence of a cold environment on sanitary engineering works and services, water supply engineering in cold regions, and water supply during military field operations. Report includes a bibliography.

AD-688 132 -- POLYURETHANE FOAMS: TECHNOLOGY, PROPERTIES AND APPLICATIONS, A. H. Landrock, Picatinny Arsenal, Dover, N. J., Jan. 69, available in paper copy only, \$15.50, 257p. . . . Discusses state-of-the-art of urethane foams; methods of manufacturing urethane foam process; types of polyurethane foam; methods of manufacture; toxicity of raw materials; adhesives and other methods of joining; surface coatings; foam properties; test methods; military and space applications; economics and costs; comparative properties of other foams; specifications and standards; trade designations; and definitions of terms. Report includes a bibliography of over 700 references from the open literature, government project and contract reports, commercial bulletins, and conference papers.

AD-686 723 -- WIND SURFING--A NEW CONCEPT IN SAILING, J. R. Drake, RAND Corp., Santa Monica, Calif., Apr. 69, 23p. . . . Describes various board and sail configurations used in wind-surfing. The hand-held fully articulated sail is an entirely new means of propulsion and control.

This one is great, a stand-up surfboard with a ball-joint flexible-boom sail. Surf in, then turn around and surf out. Design and instructions.

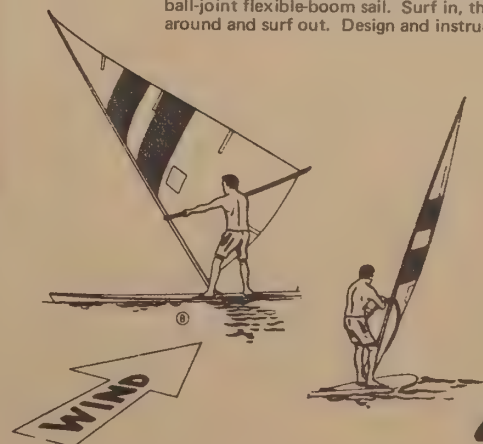

**Science**

This magazine of the American Association for the Advancement of Science is completely unloveable. It does have information you can't find anywhere else sometimes, but something sure is missing from the magazine and perhaps from the scientists, however liberal. It's like they hate to communicate.

Science \$12/yr. (weekly)

from: American Association for the Advancement of Science 1515 Massachusetts Avenue, N. W. Washington, D. C. 20005

Railroad in southern Alaska, shown in a 1960 photo by USGS, is like a roller coaster from differential settlement of disturbed permafrost. The Trans Alaska Pipeline, carrying hot oil, may face worse problems. [L. A. Yehle]



**Alaska May or May Not Become a Kuwait of the Arctic but the Oil Men's Arrival Is Changing a Wilderness**

Abstract. Pigeons pecked a response disk to gain access to grain rewards while identical grain was freely available from a cup within the experimental chamber. Similarly, rats pressed a lever for food pellets while free pellets were present. It is not necessary, therefore, to deprive an animal of food before it will engage in instrumental responding for food. Such responding can serve as its own motivation and reward.



Science and Civilization in China, Volume IV, Part 2

Joseph Needham is a renowned biologist who travelled into unexplored regions of Chinese technological history and became a yet more renowned historian and interpreter of what is for most of us the back of the planet. His series is awesome in size and depth; he's done the mining, but you've got to refine the ore to suit your own purposes. One purpose I know was Vic Lovell's, who found in Vol. I a rich lode of information on Taoism and how its influence helped the Chinese discover and utilize some technology long before the West and also overlook or never utilize other stuff that the West seized on. Another purpose might be taking some of the mechanical inventions of old China—from man-kites to water-wheels—and applying them to the hand technology of intentional communities. There's no source like the source in these matters.

Of the following, only Vol. IV, Part 2 is available at present from the WHOLE EARTH CATALOG. All quotes and illustrations are from that book.

Science and Civilization in China

- Joseph Needham
- Vol. I Introductory Orientations, 1954: \$15.00
- Vol. II History of Scientific Thought: \$17.50
- Vol. III Mathematics and Science of the Heavens and the Earth, 1959: \$30.00
- Vol. IV Pt. 1 Physics, 1962: \$16.50  
Pt. 2 Mechanical Engineering, 1965: \$35.00

from: Cambridge University Press, 510 North Avenue, New Rochelle, N.Y. 10801 or WHOLE EARTH CATALOG

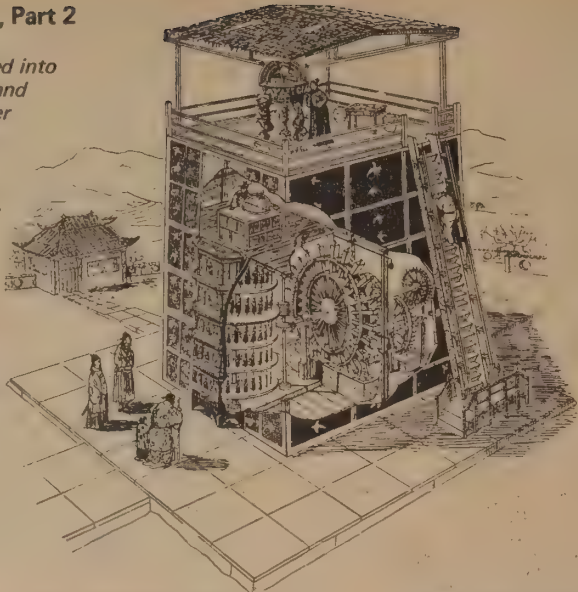
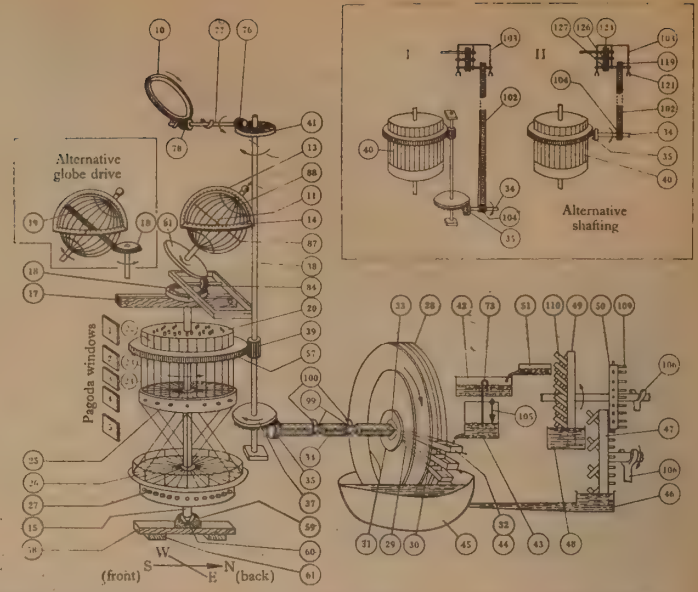

Fig. 650. Pictorial reconstruction of the astronomical clock-tower built by Su Sung and his collaborators at Khaifeng in Honan, then the capital of the empire, in +1090. The clockwork, driven by a water-wheel, and fully enclosed within the tower, rotated an observational armillary sphere on the top platform and a celestial globe in the upper storey. Its time-announcing function was further fulfilled visually and audibly by the performances of numerous jacks mounted on the eight super-



imposed wheels of a time-keeping shaft and appearing at windows in the pagoda-like structure at the front of the tower. Within the building, some 40 ft. high, the driving wheel was provided with a special form or of escapement, and the water was pumped back into the tanks periodically by manual means. The time annunciator must have included conversion gearing, since it gave 'unequal' as well as equal time signals, and the sphere probably also had this (see p. 456).

Su Sung's treatise on the clock, the *Hsin I Hsiang Fa Yao*, constitutes a classic of horological engineering. Orig. drawing by John Christiansen. The staircase was actually inside the tower, as in the model of Wang Chen-To (7). The historical significance of the mechanical rotation of an astronomical instrument (a clock-drive) has already been discussed in Vol. 3, pp.359ff., cf. also p.492 below.

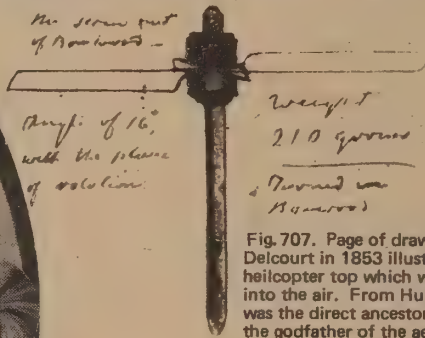

Fig. 707. Page of drawings sent by Cayley to Dupuis-Delcourt in 1853 illustrating an improved Chinese helicopter top which would mount more than 90 ft. into the air. From Hubbard & Ledebor (1). This was the direct ancestor of the helicopter rotor and the godfather of the aeroplane propeller

Allusion has already been made to the 'south-pointing carriage' (chih nan chhe) in Sect. 26i on magnetism, since it was long confused, both by Chinese and Westerners, with the magnetic compass. We know now, however, that it had nothing to do with magnetism, but was a two-wheeled cart with a train of gears so arranged as to keep a figure pointing due south, no matter what excursions the horse-drawn vehicle made from this direction.

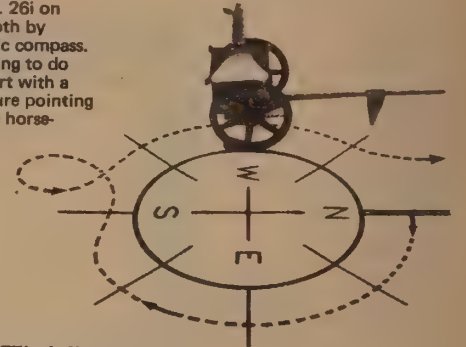
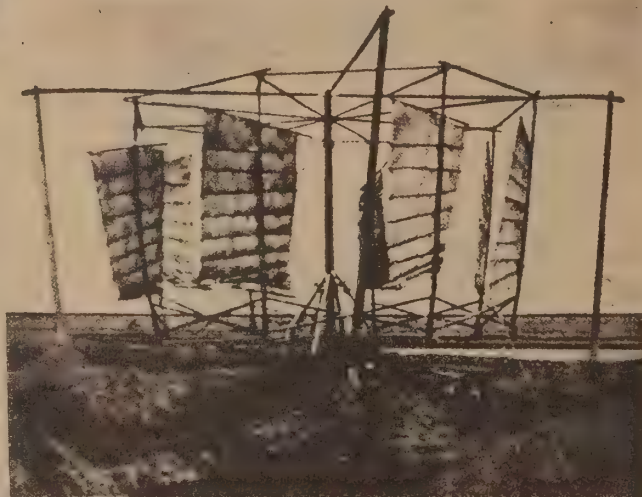
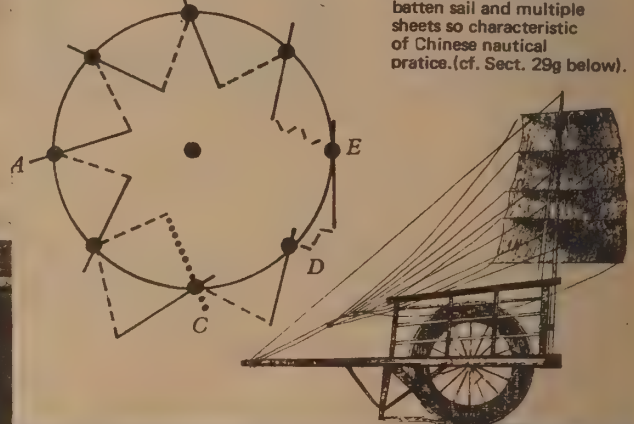

Fig. 519. Diagram of a sailing wheelbarrow from van Braam Houkgeest (+1797), showing the batten sail and multiple sheets so characteristic of Chinese nautical practice.(cf. Sect. 29g below).

Fig. 689. Typical Chinese horizontal windmill working a square-pallet chain-pump in the salters at Taku, Hopei (king, 3). The fore-and-aft mat-and-batten type sails luff at a certain point in the cycle and oppose no resistance as they come back into the eye of the wind (see diagram on p. 559)



Wind direction



Human Engineering Guide

Buy this book and keep it at hand at all times if you design or build anything that will be used by, for, or come in contact with people. Concise statement of ideas both through the informative writing and clear illustrations. The authors have followed their own guidelines and produced a device (this book) which will do well what it was designed to do, transfer a large amount of information between people. If you want information on human engineering, design of equipment and work space, vision, audition and body measurement, it's all in this book chapter by chapter. The above categories are a partial list of actual chapter headings. This book should be used by all design engineers, but it is not necessary to be a design engineer or even an engineer to use it. Really fundamental ideas clearly stated can be understood by anyone.

[Reviewed by F. Le Brun]

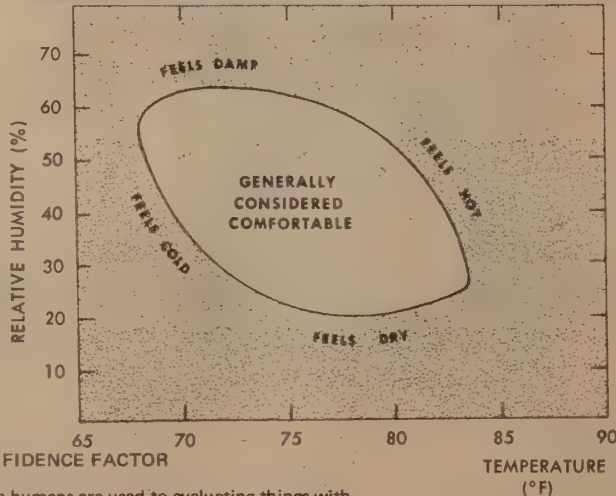
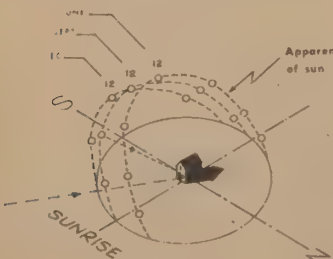

Since humans are used to evaluating things with "all their senses" from the time they are born, it is natural for them to expect this. Each of the sensory inputs, in fact, raises the level of confidence of the operator in what he is receiving - thus the converse of this, i.e., lack of certain inputs, tends to reduce the operator's confidence in the information he is receiving.

Human Engineering for Equipment Designers  
Wesley E. Woodson, Donald W. Conover  
1954,66; 473pp

\$10.00 postpaid

from: University of California Press  
2223 Fulton St.  
Berkeley, Ca. 94720

or WHOLE EARTH CATALOG

When a click in one ear leads that in the other by about 0.03 millisecond, the sound just begins to shift toward the first side; when there is a time difference of 0.65 millisecond or more, the sound appears completely localized on the side of first arrival, this localization remaining until the time difference becomes so great (3 milliseconds or more) that fusion is lost and the sound is heard separately in the two ears.

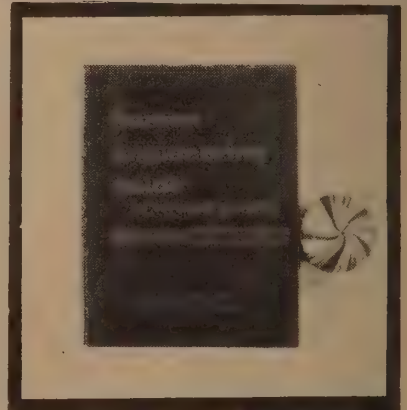

Where possible, work should be held by jigs or vises so that hands may be free to operate.

Hesitation - or the temporary and often minute cessation from motion - should be analyzed; its cause should be accounted for and, if possible, eliminated.

**Thomas Register of American Manufacturers**

Let it all hang out: 7 volumes, 10,000 pages, 50,000 product ads, 70,000 classifications. It's the great American industrial yellow pages—and like the yellow pages, an education. If the Sears Catalog will tell you where American consumption is at, TR tells you what's happening in production. And if you're trying to make the switch toward production, TR can help you find what you need.

Thomas Register published annually in the summer  
\$30.00 postpaid

from:  
Thomas Publishing Company  
461 Eighth Avenue  
New York, N. Y. 10001

also available in most libraries

**MARKET FORMS FOAMS**

for packaging cushioning ceiling insulation protection decoration or what you need

**NEW!** MARKEL FLOAM complex 3D shape of resilient polyethylene foams combines "instant" a more fooling with high production rates for lowest cost and fast delivery of long and short runs of customers' colorings for glassware electrical and electronic parts, pharmaceutical optical lenses, mirrors, etc. and all delicate and high-value items.

**PRESTO-FOAMS URETHANES**

ENGINEERED FOR INDUSTRY

For PACKAGING • VIBRATION & SOUND DAMPING • BASKETS

Commercial • Military Space

IN STOCK: SPONGE RUBBER HOOPERS & VINYL FOAM

**PRESTO Manufacturing Co. Inc.**

**PROTECTIVE FOAM PLASTICS**

ANY SHAPE - ANY SIZE

PACKAGING CUSHIONING  
BASKETING INSULATING

WE USE: CELLULOSE, WAX, FIBRE, FIBREGLASS, LAMINATE

**CONRAY PRODUCTS CO.**

**CARTEX**

CUSTOM RUBBER PRETHANE & LUREX FOAM

CARTEX CORPORATION

**MORE HOURS OF WEAR • MORE ECONOMICAL ...**

**SARJANIAN**

PLASTIC COATED INDUSTRIAL GLOVES

COVER-FINGERED, WINGED FINGER PATTERNS AND PRE-CREATED FINGERED PATTERNS

**SARJANIAN GLOVE COMPANY**

**CG**

**CARDINAL GLOVES**

MADE IN U.S.A.

**SAFETY GLOVES AND MITTENS**

WELDING GLOVES

**AMERICAN OPTICAL COMPANY**

**KIND OF INFORMATION T. R. WILL FURNISH**

For every industry, every manufacturer, every product, anywhere in the U. S. A.

VOLUMES 1, 2, 3, 4, 5 & 6

VOLUME 7

- Does anyone in Alabama make Cast Iron Pipe?
- Are Induction Coils manufactured in Wyoming?
- Who makes Electric Motors in Michigan?
- Is there a large manufacturer of Rubber Hose in Connecticut?
- Trademark Section.
- Where are the plants of the Allis-Chalmers Mfg. Co.?
- Who succeeded the Acme Rubber Mfg. Co.?
- Where is the home office of the Bristol Brass Corp.?
- How many products does General Electric make and what are they?
- Is Novo Pump & Engine Co. a parent company or subsidiary?
- Where are the branch offices of the Star Expansion Co.?
- What is the capital rating of the Western Supply Co.?
- Who are the officials of the Erie Foundry Co.?
- What is the cable address of Acme Viscose Records, Inc.?
- What companies does Howmet Corp. own or control?

**Handbook of Chemistry and Physics**

Among handbooks this one is unusually wealthy in basic information. Its 6-figure math tables are the standard (they're obtainable separately: \$6.50 from Chemical Rubber). Its chemistry and physics tables constitute a comprehensive inventory of invisible effects. It doesn't teach you how to use or even read the inventory, but if you know-how, here's the know-what tool chest.

[Suggested by Lloyd Martin]

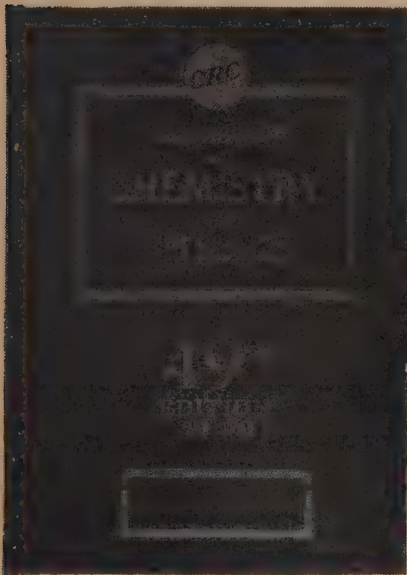

**Handbook of Chemistry and Physics**  
Robert C. Weast, ed.  
1918...1968  
(49th Edition); 3604 pp.  
\$12.50 postpaid

from:  
The Chemical Rubber Co.  
18901 Cranwood Parkway  
Cleveland, Ohio 44128

or WHOLE EARTH CATALOG

**Machinery's Handbook**

If you make things out of metal you need Machinery's Handbook. This thick, comprehensive guide to shop and engineering practice was originally designed to fit in the tall center drawer of a machinist's chest. Machinist's chests have stayed the same size, but the shaping of metal has become more and more complicated. Machinery's has coped with the squeeze heroically; the current (18th) edition contains 2293 pages printed on fine India paper, and it still fits the drawer. You can find in it things like tap drill sizes for S.A.E., metric, and Whitworth threads, what welding rod to use for which metal, and how much weight you can hang on a rope if it goes around a fat (or thin) barrel. You can also look up logarithms, area, volumes, and centers of gravity, and learn how to design helical gears, replace bearings, grind a lathe bit, and do many other useful and not-so-obvious things. The book is divided into thirteen main sections, indexed, thumb-indexed, and bound in tough, satisfyingly archaic industrial green with gold stamping.

[Suggested and reviewed by Dr. Morton Grosser]

**Chemical Formulary**

You don't have to buy soap, glue, toothpaste, paint, gum, ink, medicine, sealers, waterproofing, etc. You could make them. An exhaustive list of recipes exists in the Chemical Formulary, 13 volumes of practical alchemy for the home.

[Suggested by Pat Rowan]

**Chemical Formulary, Vols. 1-13**  
Harry Bennett, ed.

\$8 /vol. (Cumulative Index, \$12)

from:  
Chemical Publishing Company  
Tudor Publishing Company Division  
221 Park Avenue South  
New York, N. Y. 10003

or many public libraries free.

Table 1. American Standard (see Steel Pipe) Flange

Nom. Pipe Size	Inside Diam. Flange	Min. Web Thickness	Flange Diam.	Flange Thickness	Bolt Circle Diam.	No. of Bolts	Bolt Size	Distances to Contact Surface of Raised Face				
								AA	BB	CC	DD	
1 1/2	1 1/2	1/4	4 1/2	1 1/4	3 1/2	4	5/16	4 1/2	1 1/4	1 1/4	1 1/4	1 1/4
2	2	1/4	5 1/2	1 1/4	4 1/2	4	5/16	5 1/2	1 1/4	1 1/4	1 1/4	1 1/4
2 1/2	2 1/2	1/4	6 1/2	1 1/4	5 1/2	4	5/16	6 1/2	1 1/4	1 1/4	1 1/4	1 1/4
3	3	1/4	7 1/2	1 1/4	6 1/2	4	5/16	7 1/2	1 1/4	1 1/4	1 1/4	1 1/4
3 1/2	3 1/2	1/4	8 1/2	1 1/4	7 1/2	4	5/16	8 1/2	1 1/4	1 1/4	1 1/4	1 1/4
4	4	1/4	9 1/2	1 1/4	8 1/2	4	5/16	9 1/2	1 1/4	1 1/4	1 1/4	1 1/4
4 1/2	4 1/2	1/4	10 1/2	1 1/4	9 1/2	4	5/16	10 1/2	1 1/4	1 1/4	1 1/4	1 1/4
5	5	1/4	11 1/2	1 1/4	10 1/2	4	5/16	11 1/2	1 1/4	1 1/4	1 1/4	1 1/4
5 1/2	5 1/2	1/4	12 1/2	1 1/4	11 1/2	4	5/16	12 1/2	1 1/4	1 1/4	1 1/4	1 1/4
6	6	1/4	13 1/2	1 1/4	12 1/2	4	5/16	13 1/2	1 1/4	1 1/4	1 1/4	1 1/4
6 1/2	6 1/2	1/4	14 1/2	1 1/4	13 1/2	4	5/16	14 1/2	1 1/4	1 1/4	1 1/4	1 1/4
7	7	1/4	15 1/2	1 1/4	14 1/2	4	5/16	15 1/2	1 1/4	1 1/4	1 1/4	1 1/4
7 1/2	7 1/2	1/4	16 1/2	1 1/4	15 1/2	4	5/16	16 1/2	1 1/4	1 1/4	1 1/4	1 1/4
8	8	1/4	17 1/2	1 1/4	16 1/2	4	5/16	17 1/2	1 1/4	1 1/4	1 1/4	1 1/4
8 1/2	8 1/2	1/4	18 1/2	1 1/4	17 1/2	4	5/16	18 1/2	1 1/4	1 1/4	1 1/4	1 1/4
9	9	1/4	19 1/2	1 1/4	18 1/2	4	5/16	19 1/2	1 1/4	1 1/4	1 1/4	1 1/4
9 1/2	9 1/2	1/4	20 1/2	1 1/4	19 1/2	4	5/16	20 1/2	1 1/4	1 1/4	1 1/4	1 1/4
10	10	1/4	21 1/2	1 1/4	20 1/2	4	5/16	21 1/2	1 1/4	1 1/4	1 1/4	1 1/4
10 1/2	10 1/2	1/4	22 1/2	1 1/4	21 1/2	4	5/16	22 1/2	1 1/4	1 1/4	1 1/4	1 1/4
11	11	1/4	23 1/2	1 1/4	22 1/2	4	5/16	23 1/2	1 1/4	1 1/4	1 1/4	1 1/4
11 1/2	11 1/2	1/4	24 1/2	1 1/4	23 1/2	4	5/16	24 1/2	1 1/4	1 1/4	1 1/4	1 1/4
12	12	1/4	25 1/2	1 1/4	24 1/2	4	5/16	25 1/2	1 1/4	1 1/4	1 1/4	1 1/4
12 1/2	12 1/2	1/4	26 1/2	1 1/4	25 1/2	4	5/16	26 1/2	1 1/4	1 1/4	1 1/4	1 1/4
13	13	1/4	27 1/2	1 1/4	26 1/2	4	5/16	27 1/2	1 1/4	1 1/4	1 1/4	1 1/4
13 1/2	13 1/2	1/4	28 1/2	1 1/4	27 1/2	4	5/16	28 1/2	1 1/4	1 1/4	1 1/4	1 1/4
14	14	1/4	29 1/2	1 1/4	28 1/2	4	5/16	29 1/2	1 1/4	1 1/4	1 1/4	1 1/4
14 1/2	14 1/2	1/4	30 1/2	1 1/4	29 1/2	4	5/16	30 1/2	1 1/4	1 1/4	1 1/4	1 1/4
15	15	1/4	31 1/2	1 1/4	30 1/2	4	5/16	31 1/2	1 1/4	1 1/4	1 1/4	1 1/4
15 1/2	15 1/2	1/4	32 1/2	1 1/4	31 1/2	4	5/16	32 1/2	1 1/4	1 1/4	1 1/4	1 1/4
16	16	1/4	33 1/2	1 1/4	32 1/2	4	5/16	33 1/2	1 1/4	1 1/4	1 1/4	1 1/4
16 1/2	16 1/2	1/4	34 1/2	1 1/4	33 1/2	4	5/16	34 1/2	1 1/4	1 1/4	1 1/4	1 1/4
17	17	1/4	35 1/2	1 1/4	34 1/2	4	5/16	35 1/2	1 1/4	1 1/4	1 1/4	1 1/4
17 1/2	17 1/2	1/4	36 1/2	1 1/4	35 1/2	4	5/16	36 1/2	1 1/4	1 1/4	1 1/4	1 1/4
18	18	1/4	37 1/2	1 1/4	36 1/2	4	5/16	37 1/2	1 1/4	1 1/4	1 1/4	1 1/4
18 1/2	18 1/2	1/4	38 1/2	1 1/4	37 1/2	4	5/16	38 1/2	1 1/4	1 1/4	1 1/4	1 1/4
19	19	1/4	39 1/2	1 1/4	38 1/2	4	5/16	39 1/2	1 1/4	1 1/4	1 1/4	1 1/4
19 1/2	19 1/2	1/4	40 1/2	1 1/4	39 1/2	4	5/16	40 1/2	1 1/4	1 1/4	1 1/4	1 1/4
20	20	1/4	41 1/2	1 1/4	40 1/2	4	5/16	41 1/2	1 1/4	1 1/4	1 1/4	1 1/4

**Machinery's Handbook**  
1914...1969; 1192 pp.  
\$16.00 postpaid

from:  
Industrial Press, Inc.  
200 Madison Avenue  
New York, N. Y. 10016

or WHOLE EARTH CATALOG

**Machinery's Handbook**

10th Edition

REVISED AND ENLARGED

**WATER AGAINST AIR**

Temperature °C	Surface tension dynes/cm.	Temperature °C	Surface tension dynes/cm.	Temperature °C	Surface tension dynes/cm.
-8	77.0	15	73.49	40	69.56
-5	78.4	18	73.05	50	67.91
-0	78.6	20	72.75	60	66.18
5	74.9	25	71.97	70	64.4
10	74.22	30	71.18	80	62.6
				100	58.9

**INTERFACIAL TENSION**

Surface Tension at the Interface Between Two Liquids (Each liquid saturated with the other)

Liquids	Temperature °C	γ	Liquids	Temperature °C	γ
Benzene-Mercury...	20	357	Water-Heptylic acid	20	7.0
Ethyl ether-Mercury	20	379	Water-n-Hexane...	20	51.1
Water-Benzene...	20	35.00	Water-Mercury...	20	375
Water-Carbon tetrachloride	20	45.	Water-n-Octane...	20	50.8
Water-Ethyl ether...	20	10.7	Water-n-Octyl alcohol	20	8.5

**ANT POISON**

Sugar 1 lb.  
Water 1 qt.  
Arsenate of Soda 125 g.

Boil and stir until uniform; strain through muslin and add 1 spoonful honey.

**BEDBUG EXTERMINATOR**

Kerosene 90 fl. oz.  
Clove Oil 5 fl. oz.  
Cresol 1 fl. oz.  
Pine Oil 4 fl. oz.

Simply mix and bottle.

**NONSTAINING MOTHPROOFING FLUID**

Sodium Aluminum Silicofluoride 0.50  
Water 98.00  
Glycerin 0.50

"Sulfate" (Wetting Agent) 0.25

Stir until dissolved.

**CRESOL DISINFECTANT**

Caustic Soda 25.5 g.  
Water 140.0 cc.

Dissolve in a Pyrex or enamelled dish and warm. To this, add slowly the following warmed mixture:

Cresylic Acid 500.0 cc.  
Rosin 170.0 g.

Stir until dissolved and add water to make 1,000 cc.

## Silvo Hardware

Tools tools tools tools. Brand names. Mostly good stuff. Several quality levels on almost all items. If you know what you want, it is probably here. Prices good, sometimes not as good as U.S. General. I have been pleased by their service on returned items. Takes about two and a half weeks to West Coast. Minimum order \$10.00.

[Reviewed by  
Fred Richardson]

Silvo Catalog  
146 pp.

\$25

from:  
Silvo Hardware Co.  
c/o Mr. Collins,  
Advertising Dept.  
107 Walnut Street  
Philadelphia, Penna.  
19106



## HOLD DOWN CLAMP

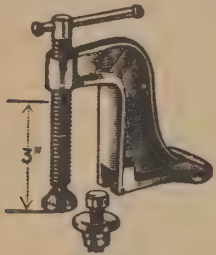

No. 1623

**Jorgensen Hold-Down Clamps** — To hold work securely on all surfaces — Can be spotted anywhere — even in the middle of work area — on wood bench, drill press table, sawhorse, or along the side of a bench for use as a portable vise. Style No. 1623 for regular service, slides "onto" bolt-head projecting above surface, ready for action. It slides "off" to be put away when not in use. Heavy duty design. Style No. 1834 is available for extreme service. Both styles can be furnished with steel shield over screw, for welding service.

1623-A2 P—2 lbs. 3" hold-down capacity ..... \$2.15  
1623-A2 P—3 lbs. 2 3/4" hold-down capacity (shielded) ..... \$3.80  
1834-A2 P—7 lbs. 4 1/4" hold-down capacity ..... \$11.20  
1834-A2 P—8 lbs. 4" hold-down capacity (shielded) ..... \$13.35

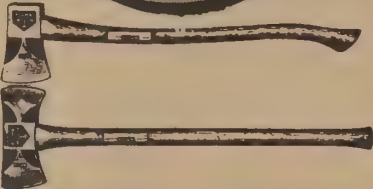

**Plumb Jet Wing Axes** — Full polished head — Forged from highest grade tool steel — Handles made from the finest grade hickory — PermaBond® 36" handles. Jersey pattern.

JJ35-P7 3 1/2 lbs. single bit ..... \$5.85  
JJ4-P7 4 lbs. single bit ..... \$6.05  
JMD35-P7 3 1/2 lbs. double bit ..... \$6.25



**Slive Universal Bearing Tool** — takes the place of arbor press or drifts, for the removal and installation of sleeve bushings or bearings. The portability of these tools permit their use on the bench or in the field. In limited space or close quarters or hard to get at places, working on heavy housings, the value of these tools cannot be surpassed. The even pressure exerted by the shouldered adapters cannot pain the bushing and nor crack the housing. Scratches and other marks are eliminated. Working parts are hardened. Tools have a rust proof finish.

Removes bearings from 1/2" O.D. to 1 1/2" O.D. Equipped with 5 adapters plus small Vac Adapter tube and stem.

700-C13 P—5 lbs. .... \$10.75



**K.V. Adjustable Standards**—Slots allow 1-inch adjustments in shelf spacing to any desired location on standard. Made of cold rolled steel, satin anochrome finish. Use with wood, metal, glass or plastic shelves.

80A-K12 36" 20 for—\$10.69 2 for—\$12.25  
80A-K12 48" 20 for—\$14.25 2 for—\$16.65  
80A-K12 72" 20 for—\$21.35 2 for—\$24.49

**K-V Bottless Shelf Brackets**—for use with K-V 80 standards. Cold rolled steel, anochrome finish. Patented friction grip assures a firm, level hold with perfect alignment on standard. Satin anochrome finish.

180A-K12 6" 20 for—\$5.89 2 for— .75  
180A-K12 8" 20 for—\$5.98 2 for— .79  
180A-K12 10" 20 for—\$7.10 2 for— .86  
180A-K12 12" 20 for—\$7.85 2 for— .98



**Wet Grindstone** — Equipped with genuine natural Ohio 10" x 1 1/2" x 1/2" grindstone. Base 5" x 12" height 11 1/2". Stone is operated at 130 R.P.M. in water. Ideal for sharpening fine-tempered tools without drawing temper from same. No. G7 complete as shown above.

G7-P15 H—32 lbs. .... \$19.60



## CAM GRIPS INSIDE PIPE

**Internal Pipe Wrench**—Tightens and removes nipples and pipe fittings quickly and safely without damage to thread. Merely insert into pipe and turn. Comes in 4 sizes.

29-H19 3/8" size ..... \$1.75  
29A-H19 1/2" size ..... \$1.89  
29B-H19 3/4" size ..... \$2.00  
29C-H19 1" size ..... \$2.25

## WIRE ROPE CUTTERS



**Impacto Wire Rope Cutters** — Cut is made fast and at a lower cost than hydraulic or shear type cutters of equal capacity.

Shock resistant malleable iron casting is newly designed to cut dead weight without impairing strength. Tool steel blades are retained within the housing at moment of impact for safe operation. Blades are "U" shaped to help rope keep its original shape. No. 1WRC Cuts wire Rope 3/4" to 1" as shown above.

1WRC-R6 P—7 lbs. .... \$8.69

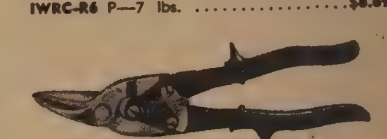

**Wiss Metalmaster Space Age Snip**—Same as Metalmaster Snips above—Except made to cut the new special space metals — Complete with vinyl plastic grips.

M1S1-W8 Cuts left ..... \$4.65  
M2S1-W8 Cuts right ..... \$4.65  
M3S1-W8 Cuts straight and comb. .... \$4.65

## BELT PUNCHES

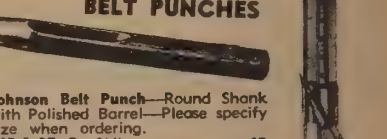

**Johnson Belt Punch**—Round Shank with Polished Barrel—Please specify size when ordering.

245-1-07 P—3/8" ..... \$1.45  
245-2-07 P—1/2" ..... \$1.46  
245-4-07 P—3/4" ..... \$1.47  
245-6-07 P—1" ..... \$1.48  
245-8-07 P—1 1/4" ..... \$1.49  
245-9-07 P—1 1/2" ..... \$1.50  
245-11-07 P—1 3/4" ..... \$1.59  
245-12-07 P—2" ..... \$1.60  
245-13-07 P—2 1/4" ..... \$1.65  
245-14-07 P—2 3/4" ..... \$1.66  
245-15-07 P—3" ..... \$1.98  
245-16-07 P—3 1/2" ..... \$1.00

**No. 110 X-Acto Mat Cutter & Beveler Knife Guide**—For fool-proof cutting of picture mats and other materials to exact size—up to 30". Makes both perpendicular and beveled cuts. Made of light magnesium. Easy to operate. For artists, photographers, architects, draftsmen and others. Complete with No. 6 Knife and instructions.

110-X1 P—3 lbs. .... \$6.50

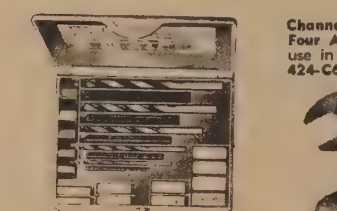

**No. XX-10 Screw & Stud Extractor Set**—20 pcs. Straight fluted extractor set in fitted die cast metal box. Contains 10 drill guides 9/32" to 9/16" O.D.; five extractors diameters 1/8" to 9/16", each equipped with special hexagonal turning adaptor and five fractional drills 1/8" to 11/32".

10-R4 P—2 lbs. .... \$10.51



**Russell Jennings Auger Bit Set**—In Wood Chest—Thirteen different sizes Standard Auger Bits in three-section nicely finished wood chest. An excellent set for the skilled woodworker and hobbyist. Sizes 4/16 to 16/16 inclusive, 100RJ Bits.

BXD32 1/2-S19 P—5 lbs. .... \$37.90

**Channellock Mity Midget Plier** — Slip Joint, Four Adjustments — A midget plier ideal for use in ignition and other small work.

424-C6 P—Cap. 1/2" x 4 1/2" long ..... \$2.00



## Lufkin Mezurlok Power Tape Rules

New 12-and 16-foot Mezurlok power tapes offer unique and unusual features. Chrome-finished case is Cyclocac®, the lightweight, rugged plastic you find in football helmets. Free and easy blade action results from a roomy case and a bearing-supported nylon spool. A rubber bumper at the mouth of the case cushions blade return shock, reduces end hook breakage. Rocker lock on front of case pushes forward to hold blade in place, pulls back to allow blade to glide into case.

12-L7 12 ft. x 3/8" ..... \$3.67  
16-L7 16 ft. x 3/8" ..... \$4.33

## Brookstone Tools

If precision tools are what you need, this company has nice ones.



## THE FILE CLEANER THAT WORKS

Most file cleaners CAN'T work — the bristles are too short, too stiff, to get down between the file teeth. This one works, and on ANY file — fine, coarse or rasp. Also clears saw teeth clogged with sawdust, metal chips or dirt. Cleans soldering tips.

It works because the bristles are just long enough, fine enough and flexible enough to get into the file teeth. Bristles are tempered steel wire for long life. A soft steel pick, held in pocket in steel back, removes stubborn particles which would otherwise gouge the work. Pays for itself over and over. Doubles and triples file life. Makes files cut faster, smoother, cleaner. About 7 3/4" long. Bristle area 3 1/2" x 1 3/8".

E-1005 File cleaner with pick ..... Each \$ 1.35  
Per dozen ..... \$13.45

## MICROPROBE SET SOLVES PROBLEMS FOR WORKERS IN MINIATURE

These probes have 5 scientifically developed shapes for micro manipulation in miniature work. Ideal for model making, electronics, biological and botanical 23 pp. dissecting, dentistry, inspection, soldering, gluing, positioning, adjusting. Excellent for hooking, unhooking small springs.

Genuine medical quality. Highly polished, hardened and tempered rustless stainless steel (solder won't stick). Hand-honed, needle-sharp tips. About 6" long.

E-1516 5-piece Microprobe Set ..... \$4.50  
Three & up ..... Each set \$4.00

## ELLIS "MAJOR" INSPECTION KIT



For close and accurate examination of equipment not normally accessible to the naked eye. The kit consists of a series of varying-length probes fitted with miniature electric lamps and lenses. By using these light probes and a combination of adjustable mirrors and magnifying fittings included in the kit, the most inaccessible spots may be viewed through very small apertures. Used for the inspection of waveguides (X, S, and Q bands), cavities, pumps, dies, valves, printed circuits, small motors, hydraulic systems, relays, switchboards, and electronic components (to name just a few). All parts interlocking and interchangeable. Included are the basic battery handle (complete with 2 "D" batteries), a 15" flexible probe, 5 rigid probes, 3 magnifying lenses, an adjustable mirror attachment with adapters, an automatic magnifier, an illuminated magnifier, a mirror handle, 2 long-stem mirrors, 2 magnifying mirrors, an adjustable mirror with handle, and additional lenses and bulbs. All items are mounted in a handsome wooden case as shown above.

348672 ..... \$155.00

## Surplus Center Equipment Catalogs

Catalog  
free  
from:  
P. O. Box 713  
Lincoln  
Nebraska  
68501

Not only are these catalogs handy to the man who may need such parts, but they can also serve as idea-generators for solving certain mechanical problems—thumb through the pages. Some of the parts are better hunted locally where you can see, try, discuss with salesmen and haggle. Some are rare and good deals. Best suited to the mechanically hip, especially away from big city sources. All 'surplus' is risky stuff unless you're familiar with it.

[Reviewed by J. Baldwin.  
Suggested by Lama Foundation.]

## 3 Horsepower Battery Motor



(ITEM #1000) \$17.91 F.O.B. Lincoln

(ITEM #1000) — New, government surplus. Powerful DC motor ideal for use to drive battery operated golf carts, scooters, trolling boats for fishermen, battery driven compressors, hydraulic pumps and uses in the field where AC current is not available.

This motor is rated 3 horsepower @ 3800 r.p.m. @ 24-volts DC. It will run very nicely on 12 or 18-volts DC at slightly reduced power, speed and current. Double fan cooled for continuous duty operation. Speed can be varied by varying the applied voltage. Rotation is clockwise but can be reversed with slight modification in connections (Instruction sheet shows you how).

## SPECIFICATIONS

- Operates on 12 to 24-VDC
- 3800 RPM @ 24-VDC
- Continuous duty rated
- Full load 115-amps.
- Idle current 10-amps.
- Speed can be varied
- Ball bearing equipped
- Rotation CW facing shaft
- Double fan cooled
- Shaft diameter 21/32"
- Size 12" x 6 1/2" x 6 1/2"
- Shipping weight 30 lbs.

## Jensen Tools

Electrical Tools primarily.  
All prices postpaid.

Jensen Catalog  
65 pp.

free

from:  
Jensen Tools and Alloys  
3630 East Indian School Road  
Phoenix, Arizona 85018

## MODEL 355 MIDGETESTER

So very small (2-3/4 x 4-1/2 x 1") it easily slips into your shirt pocket. No wonder the 355 Midgetester is so popular with all who must make basic voltage and resistance measurements "in the field." Features self-shielding movement and 10,000 ohms per volt sensitivity on both AC and DC ranges. Measures 0-3, 0-12, 0-60, 0-300, and 0-1200 V AC or DC. Has four resistance ranges (R x 1, R x 10, R x 100, and R x 1K). Accuracy ±3% DC and ±5% AC. Case complete with test leads and manual. Case available. Note: The 355 is an optional component in the JTK-16 tool kit (P. 36).

50B417 TESTER ..... \$50.00  
50B425 CASE ..... 5.50



Again tools, tools tools. Brand names, catalog number is the manufacturer's model number. More junk than Silvo, and I think they sell their mailing list. At least I get lots of junk mail that I trace to them. Prices sometimes better than Silvo, service somewhat worse. Good to compare the two, as they have different prices and different things. \$20.00 minimum order. Net costs are coded into the item number. Divide the numbers following "E" by two. Audel books are 15-25% cheaper than publisher prices.

Catalog [Reviewed by Fred Richardson]

\$1.00, refundable from:  
U. S. General Supply Corp.  
100 General Place  
Jericho, N. Y. 11753



BUY AT WHOLESALE From our Midway Dealer Inventory of NATIONALLY ADVERTISED BRANDS THE BEST TOOL VALUES

**CARBIDE SCRIBER**

Reversible, tough carbide tip lets you scribe on the hardest surfaces. In neat new barrel slimly styled like an automatic pencil for finest control and ease of handling.  
350-88E230 .....\$1.60 (\$1.15)

**Airborne Sales**

Airborne Sales Company is not the usual surplus melange. Emphasis seems to be on electrical, electronic, pneumatic, hydraulic and mechanical systems and attendant parts and pieces. Their stock includes both new and used, marine specialties, tool room items and "hard-to-find" things and stuff. Pumps and motors for a variety of applications and power sources are available. Tired of your smog producer? Develop your own electric car with motor No. 1893 (their 1965 catalog), a \$259 Westinghouse product for \$29.75. Gauges, tools and fittings are available for much of the pneumatic, electronic, hydraulic and mechanical systems common to aeronautic and space programs.

[Suggested and reviewed by C. P. Christianson]

Airborne Sales Catalog 95 pp.

\$25

from: Airborne Sales Company  
8501 Stellar Drive  
Culver City, CA 90230

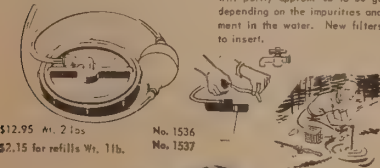

\$12.95 At 2 lbs. No. 1536  
\$2.15 for refills Wt. 1 lb. No. 1537



**HAND GENERATOR**  
Rated 10 watts at 162 volts, 0.06 amps. or 3.1 volts at 0.3 amps. Speed range 50-70 RPM. Complete with crank handle. Can also be used as a drive motor for small cars when 15 VDC is applied. Contains a reduction gear box with dual drive shafts. Reduction approx. 72 to 1. Size 5 1/2" H. x 6 1/2" W. Ship. Wt. 15 lbs. NEW. Approx. Gov't cost \$80.00.  
No. 1788 \$9.75 each



**21-PC. 3/8" SQUARE DRIVE**

This set, in sturdy metal box, contains the following tools: Reversible Ratchet, Universal Joint, 1 1/2" and 3" Extensions, and Standard Sockets sizes 3/8", 7/16", 1/2", 5/8", 11/16", 3/4", 13/16" and 7/8". And Deep Sockets 3/8", 7/16", 1/2", 5/8", 11/16", 3/4", 13/16".  
401-4521E3220 21 pieces .....\$22.98 (\$16.10)

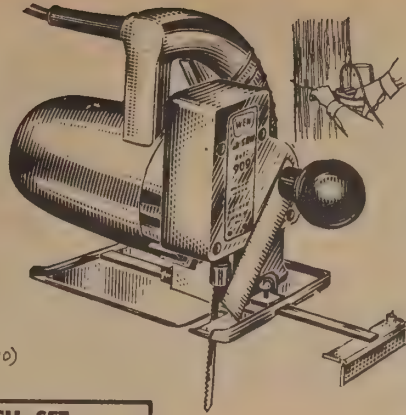

**ALL SAW**

Cuts 4x4 at 45°  
6" Log or Fine Scroll Work  
1/2 H.P. - 6 Amp. Motor

- Cuts 2x4, 4x4, 6x6, all metals up to 1 1/2"
- Cuts pipe and thin wall up to 2"
- Cuts straight, curves or any pattern
- 3400 one inch strokes per minute

Wen's "All-Saw" is designed for all around work and can do jobs that a circular saw, pattern saw, band saw, chain saw or nibbler will do. Air stream clears away dust. Roller and oilite bearings. Complete with 7 blades.  
10E-909E9900 .....\$44.95 (\$37.50)  
7 piece blade assortment.  
106-900E510 .....\$3.40 (\$2.50)



**Starrett Micrometer**  
1/10,000.  
Precision outside micrometer. Graduated .0001", with Ratchet Stop and Lock Nut. Perfect balance, better readability with correct thimble diameter. Satin chrome finish. Tapered frame gets into tight places. Rigid 1-pc. drop forged steel frame. Hi-Micro Mirror-Lapped finish on anvil and spindle faces. Easy-to-read distinct figures designed for quick-reading. With convenient decimal equivalents on anvil face.

Range 0-1" Plain Face  
351-T230RLE4450 .....\$25.35 (\$22.72)  
Range 0-1" Carbide Face  
351-T230XRLE4730 ..... 26.85 (\$23.47)

**DRIVE PIN PUNCH SET**



**3-INCH BENCH BLOCK**

Chromed vanadium steel precision machined, heat-treated and polished. 8 knurled punches in hardwood case range from 1/16 to 5/16". Ideal with Bench Block above.  
350-75E1010 \$7.20  
For driving pins, rivets in round or flat work. Holes range from 1/8" to 5/8". Has V-groove with center hole for holding odd shape stock. 3" diam., 1 1/2" high.  
350-114E1250 .....\$9.00 (\$6.25)

**CHANNELLOCK SKINNING KNIFE**



Unbreakable phenolic plastic handle. Positive blade lock prevents accidental closing of blade. Hole provided for lanyard. 3 in. precision-honed steel blade. 4" closed.  
302-10E600 .....\$4.50 (\$3.00)

**AUTOMATIC CENTER PUNCH**

Adjusts for light or heavy impressions. For instantaneous single-hand spotting. Replaceable points are made of special, rugged, tempered alloy steel. A precision-made simply-constructed quality tool, moderately priced. 1/2" diam., 5" long.  
350-79E660 .....\$4.60 (\$3.30)

**Versamatic Reversible Speed Reducer for Portable Drills**

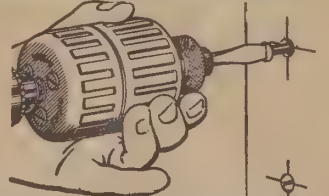

Most versatile drill attachment ever produced. Reduces speed 7 to 1 with a flick of wrist. It's a screwdriver nut runner, power tapping head. With #2 Phillips bit, medium bit, and 1/4" square drive for sockets.  
164-4100E1790 Reversing \$14.95 (\$9.95)  
1/2" Taper chuck for use with Versamatic.  
164-T33E940 #33 Taper chuck \$7.00 (\$4.70)  
VERSAMATIC with one medium bit.  
164-3800E930 No reverse .....\$6.95 (\$4.65)

**PORTABLE MANUAL HOISTS**

TESTED TO 50% OVERLOAD  
Automatic notch-at-a-time control. Weighs only 6 1/2 to 7 1/2 lbs., but out-works large, clumsy, heavy hoists. Rust resistant aircraft cable, cadmium plated steel frame and steel parts. Manganese bronze fittings. One man can lift, lower, stretch or pull up to 4000 lbs. quickly, easily, safely with these hoists.

Number	Cap., tons	Max. lift, feet	Diam., cable, feet	Leverage	Wt. lbs.	Price
933-72E3870	1	6	3/16	18:1	6 1/2	\$27.50 (19.35)
933-144E4150	1	12	3/16	18:1	7	\$29.50 (20.75)
933-216E4430	1	18	5/32	18:1	7 1/2	\$31.50 (22.15)
933-71AE5480	2	6	3/16	36:1	7 1/2	\$39.00 (27.45)

**High Grade Tool Chests**

If you enjoy reading this catalog you are probably the kind of person that is seized by an irresistible urge to open all those beautifully fitted little drawers in antique cabinets. You can satisfy the urge in your own home thanks to H. Gerstner & Sons, Inc., 20 Cincinnati Street, Dayton, Ohio, 45407. They make superb wood cases that will hold small interesting things of almost any size and shape: machinist's chests, medical instrument cases, boxes for artists, photographers, dental hygienists, and so on, ad infinitum. The thing that sets Gerstner apart from their competitors is their concern with quality. You can buy a carpenter's box from them that will stand with perfect aplomb on your Chippendale end table. Their cases are made of polished quartersawed oak, American black walnut, or can be covered with black leather or vinyl. Prices range from \$27 to \$85, and one look

will convince you that their products are a rare bargain in an injection-molded age. Their service is personal and quick; illustrated literature is available.

[Suggested and reviewed by Dr. Morton Grosser]



Literature from: H. Gerstner & Sons, Inc. 20 Cincinnati St. Dayton, Ohio 45407

**Snap-on Tools**

How much should you pay for a wrench? Snap-on Tools Corporation has built a huge business by betting that you are willing to pay more than twice as much as you would in your local hardware store. That's the approximate difference in price between Snap-on mechanics' tools and mass-distributed brands. You can gauge the success of their methods by walking into a racing pit or the service area of any premium auto repair shop. The contents of the tool chests are usually labelled 'SNAP-ON.'

What do you get for the extra money? The best steel, precision machining and heat treatment, superb finishing, and an unconditional guarantee. It is hard to explain the merit of fine tools to people content with dime-store quality, but a Snap-on tappet wrench will convince you that a tool can be a work of art.

Where can you buy them? Snap-on tools are sold from rolling salesrooms, and local representatives are listed in the telephone book. The truck will come to your house if you like, or you can arrange to meet the sales representative at a mutually convenient place. Assuming you can afford it, you can outfit a complete repair shop from a typical Snap-on truck. As a price reference, a Snap-on 3/8" square drive double hex socket set contains a ratchet handle, a speeder, a sliding T-bar, a nut spinner, three extension bars, a universal joint, and 11 double hex sockets, and costs \$45.62. A set of six ignition wrenches costs \$9.36. Not cheap, but you'll know why they're listed here as soon as you handle them. A free 150-page illustrated catalog is available from all Snap-on representatives.

[Suggested and reviewed by Dr. Morton Grosser]

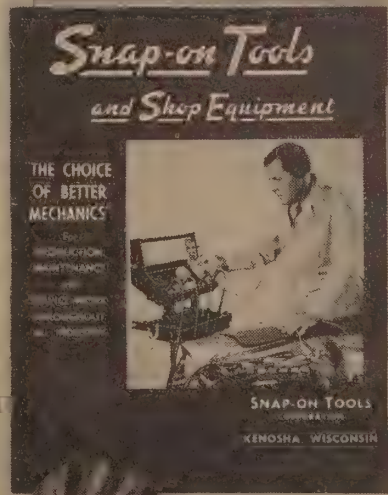

Catalog from Snap-on Tools Corp. Kenosha, Wisc. 53140

**★ Government Product-News**

This is a goofy array of new products ranging from police equipment to seam sealant that can be applied to a wet or oily surface without cleaning it first (and whoop dee doo if that one works!) A subscription would be useful to a buyer for a school system or the like, but would be of limited value to a commune. It's one of those things that new products freaks and designers like to read once a month but isn't really worth the price of the subscription to typical private citizen. Read it at your local business library.

I dig it.  
[Reviewed by Jay Baldwin.  
Suggested by J. Cline]

**ACRYLIC SEAM SEALANT sticks to oily and moist surfaces**



Product: Long-life, high-elongation sealant which can be applied directly to oily or moist surfaces without impairing adhesion or performance. Purpose: Provides an absolute seal against moisture, dust, and other influences, maker says, without prior cleaning of either factory-assembled or site-assembled construction components. Features: Molecular action of the sealant is said to form a bond just as tight as that formed on an uncontaminated surface (peel strength of 38 lbs per inch width). The sealant's unique properties resulted from polymerization of an acrylic terpolymer, with a fumed silica achieving precise viscosity control.

Circle 302 for more facts from: Schnee Morehead Chemicals, Inc. Irving, Texas



**GIGANTA** . . . the latest playground skyscraper from Jamison. 22 feet high. Kids climb into the head safely: they're inside. Two giant tube slides keep them moving, not waiting. Want more details?

Equip your parks in different themes . . . give the children of your community the maximum variety of wholesome new learning experiences . . . while they play. With FANTASY BY JAMISON equipment you can have 4 parks with completely different play environments. Choose from 4 basic themes: Space Age, Pioneer, Nautical, and Storybook.

**Jamison fantasy playground equipment**  
JAMISON, INC., BOX 2970, TORRANCE, CALIFORNIA 90509

**★ Defender Industries**

If boating is your bag & you are a self-help enthusiast you need the "Defender Industries" catalog of marine hardware & accessories. If it has to do with boats, they have it: engines to dacron sails, bilge alarms to fiberglass roving. Included are pages of information on new products, application procedures for some of the materials, construction & maintenance tips for boaters and a page devoted to "How to Build a Fiberglass Boat." Defender Industries claim that they are "one of the most complete marine supply firms in the world." They say their prices are competitive and "should we be undersold on any current standard materials, you may place your order at the lower price by merely including a tear sheet from the cheaper source, and we will fill your order."

Catalog [Suggested and reviewed by C. P. Christianson]  
\$.50 from: Defender Industries, Inc. 384 Broadway New York, N. Y. 10013

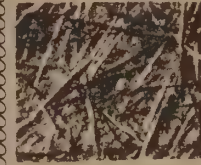

**FIBERGLAS MAT. chromed**

Long, criss-crossed, interlocking fibers, non-woven but matted to provide thickness and a high absorptive vehicle for resin work on moulding Boats, Autos, Forms, etc.

One of the largest supplies of matting on hand in U.S.A. We generally can supply any weight and width for immediate delivery. Fast "wet out", even thickness. Finest quality mat made anywhere in the country. Large quantity users please contact us for our low per pound prices.

Basic weight 1 1/2 oz. - Basic width 50" **G9-11**

Weight PSF	1-20 yds. 36"	21-40 yds. 36"	1-20 yds. 44"	21-40 yds. 44"	1-20 yds. 50"	21-40 yds. 50"	1-20 yds. 60"	21-40 yds. 60"
3/4 oz.	.85	.62	.99	.79	1.12	.89	1.33	1.03
1 1/2 oz.	1.19	.95	1.39	1.09	1.52	1.29	1.80	1.45
2 oz.	1.49	1.22	1.80	1.47	1.99	1.80	2.50	1.95

**PHENOLIC MICROBALLOONS G9-10**

Standard Oil of Ohio Product, microscopic hollow balloons—Flour like red substance—Lightens mortar mixture when used with Epoxy or Polyester. Ideal light core if weight is to be held at a minimum—Lighter than conventional laminates. Cells are nitrogen filled—Floatable. Density of 10 lbs. per cubic foot capable of reducing weight of mortar by two thirds without significant loss of strength.  
\$2.35 per pound 5 lbs. - \$9.50

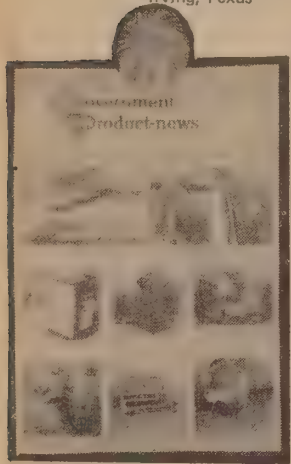

**Government Product-News \$6.00 /yr (monthly)**

from: Government Product-News 731 Hennepin Avenue Minneapolis, Minnesota 55403

**★ Tamco Plastic Supplies**

This company makes or supplies lots of plastic laboratory & commercial stuff: graduates, trays, pipe, plexiglass sheet, sewer & water pipe etc. The catalog is free, honest. I have bought a little from them and shipment has been prompt and the goods as advertised.

[Suggested and reviewed by Brooke Elgie]

**Catalog**

free

from: United States Plastic Corp. 1550 Elida Road Lima, Ohio

**POLYETHYLENE FLEXIBLE PLASTIC PIPE**

Nominal Pipe Size	Nominal I. D.	Recom'd Working Pressure 74"	Approx. Weight Per 100 Ft.	STANDARD COILS		List Price Per 100 Ft. MODERN-LINE
				Length	Outside Diameter	
1/2"	.622	100	5	400-100	3'-4"	\$ 3.68
3/4"	.824	80	7.5	400-100	3'-4"	5.95
1"	1.049	80	12	300-100	3'-4"	9.51
1 1/4"	1.380	80	23	300-100	4'-8"	15.79
1 1/2"	1.610	80	31	250-100	5'-9"	20.86
2"	2.067	80	51	200-100	6'-0"	37.74

**OUR BEST**

**HI-LINE**

AVAILABLE IN BLACK ONLY

**★ Smith Welding Equipment**

Professional welding equipment.

[Suggested by Jerome Skuba]

Catalog free

from: Smith Welding Equipment 27th Avenue & 4th Street S. E. Minneapolis, Minnesota 55414

**Meccano**

Meccano, originated by Frank Hornby, a Liverpool inventor, in 1901, was the prototype miniature metal construction system. American children are familiar with Erector, European kinder with Trix and Marklin, but they all spring from Hornby's original brainchild. Meccano is sold today from open stock, and in sets ranging in price from \$2.00 to \$160.00. There are hundreds of extra specialized parts available, and power units including two sizes of clockwork motors (these are genuine governor-controlled drives, not flimsy windups), four different electric motors operating on 4 1/2 volts D.C. to 240 volts A.C., and a reversing steam engine. Meccano gears are machined brass with setscrews; most other parts are stamped and plated steel. Auxiliary sets are available for making gear transmissions, mechanisms such as intermittent drives, and generators. Plans for many complex models are available from the factory, and there is a monthly Meccano Magazine with projects such as regulator clocks described in detail.

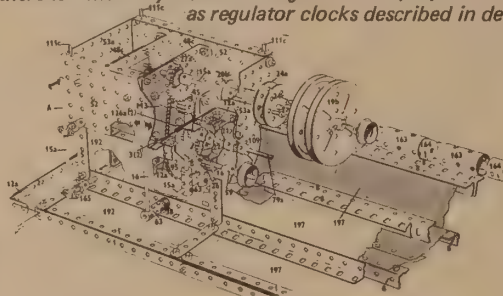

The point of all this is that if you want to breadboard an invention or a machine, Meccano is a tested, economical way to do it. Many laboratories in England carry stocks of Meccano parts to build test models with. Meccano is available in a few stores, such as Sears, in the United States, but you are better off ordering it from major British toy suppliers such as Beatties of London, 15 Broadway, Southgate, London N. 14, or Manley's, Lombard Road, Merton, London S.W. 19. After more than half a century Meccano is still a viable mechanical system. It's also a pretty good toy.

[Suggested and reviewed by Dr. Morton Grosser]

**★ Loctite Technology**

Mechanics, especially those working on old, frapped-out machinery, will dig Loctite. Anything threaded will stay together and not vibrate loose if you use the stuff. This is God's gift to the motorcycle fixer. The same company also makes a glop that you can use to make gaskets with right on the part; and for those engaged in putting new bearings in VW transmissions, they make a bearing seating compound that enables you to use wobbly old transmission cases instead of throwing them away. It works.

[Suggested and reviewed by Jay Baldwin]

Loctite Technology Catalog from: free Loctite Corporation North Mountain Road Newington, Connecticut 06111

**★ Unistrut**

Unistrut is great stuff. You can make houses, furniture, partitions, stage sets, boat trailers and just about all sorts of things out of it, and can take them apart later and use the Unistrut again. It comes in several sizes, in several metals and finishes, and is completely adjustable. I've used it for such diverse things as tables, store interiors, pack frames, animation stands and camera dollies, telescopes. Unistrut is distributed nationwide, but locally there may be competitors that offer cheaper prices and different finishes. Good for space frames such as Fuller's octet truss.

Similar in use but not in sophistication is "Giant Erector Set" slotted angle that goes under a number of trade names. It's usually called "slotted angle" or "metal lumber" in the Yellow Pages. It's particularly good for shelving and camping bus interiors, where 2X4s are not really suitable. A good brand is AIM by Acme Steel Co., 135th and Perry, Chicago 27, Ill. It costs about the same as finished lumber and takes no skill at all to use. Comes with bolts and nuts and a simple table to calculate loads. Also Good Stuff.

[Suggested and reviewed by Jay Baldwin]



AIM



Unistrut Catalogs free

from: Unistrut Corporation 4118 South Wayne Road Wayne, Michigan 48184

Unistrut

**Knots**

Being handy with knots is like having a good pocket knife; you use it so much you scarcely notice it. Without it you're forever having to apologize for your uselessness. Well sir, be embarrassed no more. Right over here we have not one but three answers to your problem—books culled by exhaustive research from the far corners of the publishing industry, books practical in outlook, terse in style, vivid in illustration, fit companion to the Holy Bible as well as the Journeyman's Handbook. With the aid of these simple texts, priced to suit the country trade, you'll soon become adept at the many methods of the master knotsman, equally at home with the Chain Sinnet and the Bowline Knot, the Butterfly Knot, and Clove Hitch, the Carrick Bend and the True-Lovers Knot.

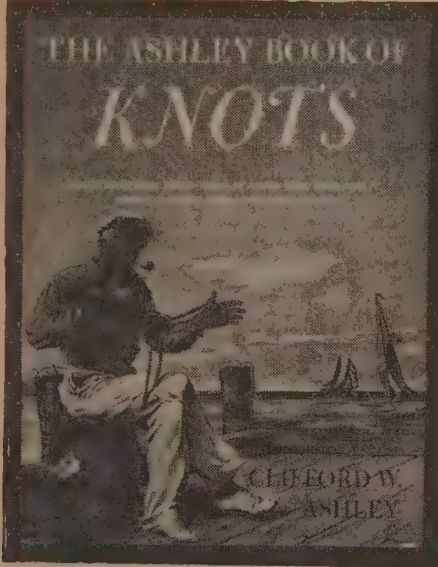

**The Ashley Book of Knots**  
Clifford W. Ashley  
1944; 260 pp.; 3900 incredible knots

**\$14.95** postpaid

from:  
Doubleday & Co., Inc.  
501 Franklin Avenue  
Garden City, N. Y. 11531

or WHOLE EARTH CATALOG

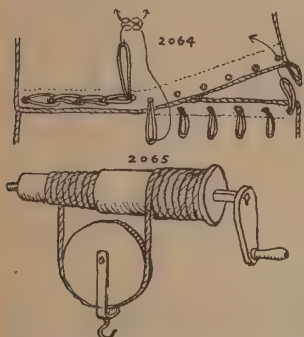

2064. *Latching* is an old method of attaching a drabber to a jib, or a bonnet to a fore and aft sail. Nowadays it is the method employed by circusmen in assembling the canvas sections of the tents. A series of eyelets in the upper section of the sail are opposite a series of loops, termed "keys," in the headropes of the bonnet. Starting at one side, a key is rove through the opposite eyelet and hauled to the next eye. The next key is rove through its opposite eye and through the key that was first led. This process is continued until the center is reached. The process is then repeated, beginning at the other edge of the sail. The two center loops, being twice as long as the rest, are reef knotted together. Captain John Smith described them in 1627, calling them "latchets."

2065. The *Chinese windlass* is the grandfather of the present-day differential chain hoist. One end winds, while the other unwinds, and the right end of the barrel, being larger than the left, winds or unwinds a greater length of rope than the left end, with each revolution of the crank.

**Zone System Manual**

This invisible book contains the essence of Ansel Adams' zone system of photography distilled by Minor White, who has his own mastery. The term for the process is pre-visualization, which is looking at reality through an accurately imagined photographic print, then knowing how to make the calculations and mechanical and chemical adjustments so that the print has what you saw. It's all here.

**ZONE**

a "Zone" as a visual unit of measurement is arrived at by altering a standard exposure by one "stop" more or one "stop" less. For example all the values in a scene exposed at f/11 at 1/25 second would print one "zone" lighter than a print of the same scene exposed at f/16 at 1/25 second. (Providing

of course that the two negatives were given identical development time and the same exposure time in the enlarger.)

This "one Stop" or "one Zone" alteration, links the "zone" to the classic 1:2 exposure ratio used in photography to calibrate shutter speeds and diaphragm openings or "stops."

EXTEND PREVISUALIZATION UNTIL THE NEGATIVE IMAGE BELOW CAN BE SEEN IN YOUR OWN EYE



WHILE LOOKING AT THIS

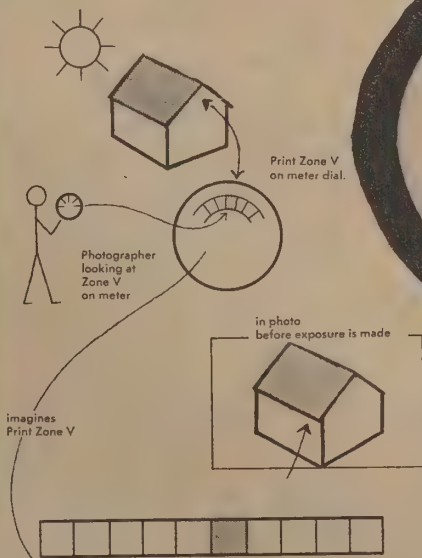

THE 1st STAGE IN PREVISUALIZATION



**Knots and Splices**  
Percy W. Blandford  
1962; 79 pp.; 80 good knots

**\$0.95** postpaid

from:  
Arco Publishing Company  
219 Park Ave. South  
New York, N. Y. 10003

or WHOLE EARTH CATALOG

**Handbook of Knots**  
Raoul Graumont  
1945; 194 pp.; 428 good knots

**\$1.75** postpaid

from:  
Cornell Maritime Press, Inc.  
Box 109  
Cambridge, Md. 21613

or WHOLE EARTH CATALOG

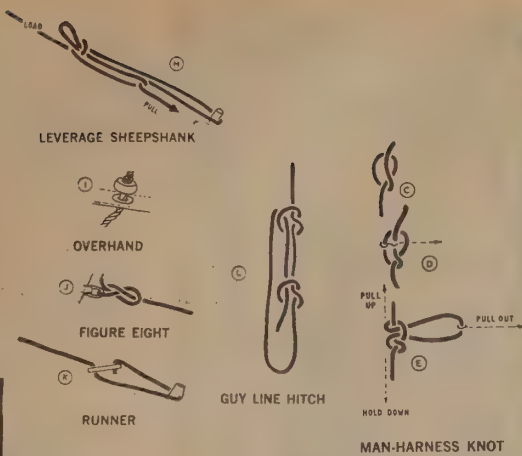

For dragging, you can get your shoulder into a bowline at the end of the rope, but if someone is needed to help you, you have to make a loop in the rope without using its ends. This can be a *man-harness knot*. Take up enough for the loop (Fig. 4C), and start to make an overhand knot in it (Fig. 4D). Instead of completing the overhand knot, grasp the opposite side of the loop through the part-knot and pull it through (Fig. 4E). To keep the knot in shape while doing this, hold one part of the rope under your foot while pulling upwards on the other part, and outwards at right angles on the loop.

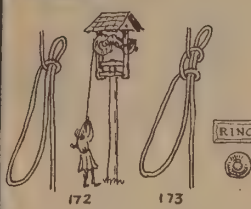
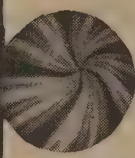

The Bell Ringer

172. The *BELL RINGER'S KNOT* is mentioned in Hutton's Dictionary of 1815. It is actually the first half of the ordinary SHEEPSHANK (#1153) and is probably a knot of considerable antiquity. Its purpose is to keep a long end of rope from lying on the belfry deck when not in use. The same knot is used in sail and rigging lofts and in ship chandleries to keep the ends of new rope off the floor.

173. If the rope is long and heavy two hitches are sometimes used instead of one, and, if necessary, several round turns may be taken instead of the single turn illustrated.

A knot having been tied or projected, the next thing in order is to "work" it, which means to draw it up snug while molding it into proper shape. The slack should be worked out very gradually. This is a matter of no less importance than correct tying, and often presents a more difficult problem, requiring both patience and practice. Carefully fair the knot, and, once having arranged the cord in symmetrical form, never allow it to become distorted, even momentarily.

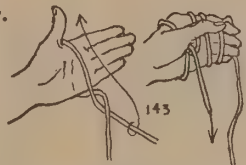

143. To break a heavy cord or string, take a turn of the cord around the left palm. Revolve the left hand so the cord is twisted in front of the palm, and wind the standing part several times around the fingers. Wrap the end (which is longer than illustrated) several times around the right hand; hold everything firm and jerk stoutly. In each of the two methods given the string crosses itself at right angles, one part being held rigidly while the other part is strongly jerked.

My first impression was that the weakening effect of this harsh crossing was the important factor in causing the string to break invariably at this point. One of the "laws" quoted in dictionary and encyclopedia knot discussions is that "the strength of a knot depends on the ease of its curves," and of course a right-angle crossing provides the unassisted curve that is possible within a knot.

Fig. 108 A: The Single Fisherman's Knot is ordinarily used to tie gut, which is less likely to slip when tied with this form of knot than when joined with a reef knot or sheet bend. It is tied with the underhand loop on the left overlapping the underhand loop on the right in the manner shown. The bight is then pulled through as the drawn in line indicates.

B: Illustrates the knot after the operation has been completed. This knot is often called an Englishman's, true lover's or waterman's knot.

Fig. 109 A: The Tom Fool's Knot or Arizona Handcuff Hitches, also known as a Conjuror's Knot, is said to have been used as a rope handcuff in the early days of the West. It can also be used as a jar or pitcher sling. It is tied by forming a loop in the manner shown, with one part of the line crossing over and the other part crossing under the knot. The bights are then pulled through as indicated.

B. The completed knot is shown here.

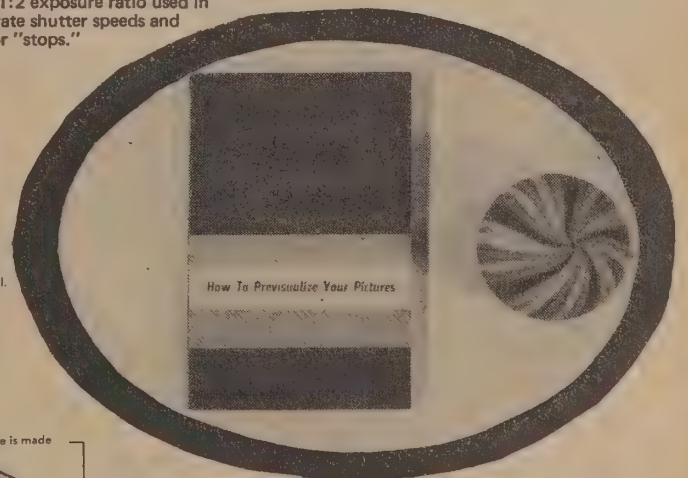
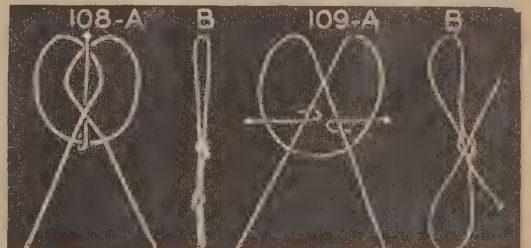

**Zone System Manual**  
Minor White  
1965; 112 pp.

**\$1.95** postpaid

from:  
Morgan & Morgan, Inc.  
25 Main Street  
Hastings-on-Hudson, N.Y. 10706

or WHOLE EARTH CATALOG

**\* The Unicorn**

If enough of this kind of thing develops the **WHOLE EARTH CATALOG** can go out of business without a backward glance

This 46-page catalog of *Books for Craftsmen* covers a much wider collection than us, is more experienced, costs far less, and they read the books. Their catalog is heaviest on weaving and needlework; they ask 15-25¢ handling charge extra per book ordered.

[Suggested by Jean Bendon]

**Books for Craftsmen Catalog**  
\$.25 postpaid

from:  
The Unicorn  
Box 645  
Rockville, Maryland 20851

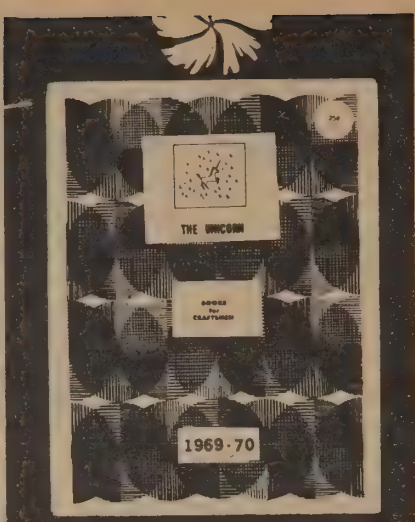

**\* The Book of Country Crafts**

Most craft books, I've noticed, either treat you as a retarded fifth grader or as an ambitious acolyte to *The Craft of whatever*. This book is by a man who grooves on doing his own stuff at his own place, and he makes you feel the same and shortens the route into doing it.

[Suggested by Jude Harris]

**The Book of Country Crafts**  
Randolph Wardell Johnston  
1964; 211 pp.  
\$4.95 postpaid

from:  
A. S. Barnes and Co., Inc.  
South Brunswick, N. J.

or **WHOLE EARTH CATALOG**



The wheel shown is made of odds and ends. The shaft is an old Ford axle. At top and bottom are the original ball bearings of the car. The flywheel is from an old circular saw and is filled with cement. The wheel head is a clutch plate fitted tightly on the shaft end, and filled with plaster. The plaster was next turned true and recessed to hold bats of a certain size, by nailing a temporary tool rest across and turning the plaster as if it were wood on a lathe. The rounded front guard is half of an old paint pail. And the seat is one of the older style, made of cast iron, from a hay rake. The cast iron ones are much superior to the pressed steel variety. I show this wheel because it has proven very handy.

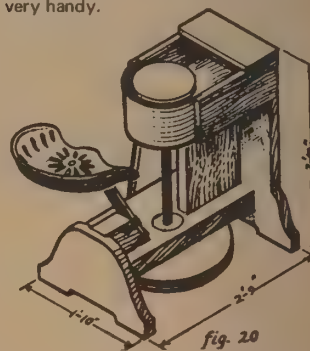

**KINDS OF STONE**

Of all the stones used by the colonists for grave markers none has better resisted the weather than slate. The neat inscriptions on slabs of polished slate show even the light scratches that served as guides to the letterers. Artists should consider this when selecting stones on which to work. Slate is a pleasant material to carve. I have carved a full-size portrait relief in gray slate, direct from life, and I found it possible to use a wooden mallet and wood-carving chisels on the stone. To be sure it took the finest edge off the chisels, but not much more than this. A fine toothed claw chisel is good for roughing out. One soon becomes accustomed to the grain. Files, rifflers, sandpaper, and pumice all help in finishing.

**Craft & Hobby Book Service**

Mail order only, *Craft & Hobby Book Service* offers a free, comprehensive and invaluable catalog of books for weavers and needle-workers. Only source for many of the titles listed. Books from all over the whole earth on hand-weaving, spinning, dyeing, loom-building, knitting, rugmaking, macramé, embroidery, tapestry, lace-making, knots & knotting, textile design. Newly revised & expanded catalog includes select titles in related fields: textile printing, batik, tie-dye, costume design, folk & primitive art & crafts, bead-work, color theory. Each book is well reviewed / catalog is thoroughly indexed / service is prompt & personal / books may be returned if not found suitable.

[Suggested and reviewed by Sarah Kahn]

Catalog  
free

from:  
Craft & Hobby Book Service  
P. O. Box 626  
Pacific Grove, CA 93950

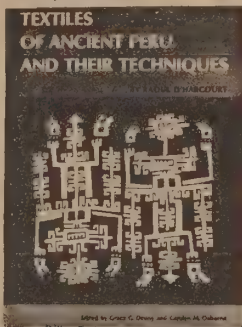

**\* A Museum of Early American Tools**

Behind making your own stuff there's another level: making your own tools to make your own stuff. This book gives detailed design information and fine illustration of America's pre-industrial tools, plus how to use them. Whistle while you work and revel in nostalgia. Tell the twentieth century to go jump.

[Suggested by Robert V. Allen]

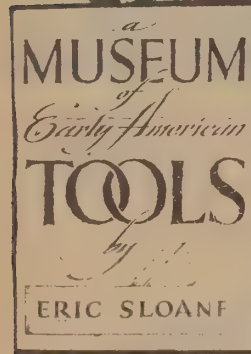

**A Museum of Early American Tools**  
Eric Sloane  
1964; 108 pp.

\$6.50 postpaid

from:  
Funk & Wagnalls  
A Division of Readers Digest Books, Inc.  
Vreeland Avenue  
Totowa, N. J. 07512

or **WHOLE EARTH CATALOG**

*The Jack Hook used any handle suited to the work.*

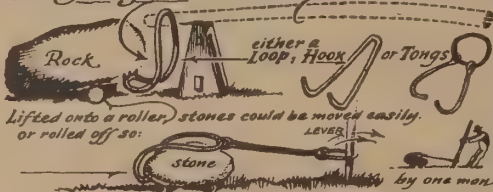

**SECTION I: On Working with Wood**

CHAPTER 1. Evolution of the New England house; restoring old houses.....	23
CHAPTER 2. Furniture construction; ways of joining wood; furniture designing.....	39
CHAPTER 3. Use of small machines; wood turning.....	51
CHAPTER 4. Finishing and refinishing materials; how to clean your brushes; wax polishes; oil finishing; staining and weathered effects.....	62
CHAPTER 5. On the art of cutting, engraving and printing wood-blocks and linoleum blocks.....	70

**SECTION II: On Working with Clay**

CHAPTER 1. Finding local clays; preparing clays; proportioning the ingredients; slip-casting.....	83
CHAPTER 2. Simple methods of making pottery.....	93
CHAPTER 3. Firing pottery without a kiln; how to build a simple wood-burning kiln; a finer kiln; oil and gas fired kilns; gauging temperature; setting the kiln.....	98
CHAPTER 4. The potters' wheel; building a wheel; how to throw.....	108
CHAPTER 5. On decorating; three-dimensional; two-dimensional; combined techniques.....	116
CHAPTER 6. On making glazes; chemistry of glazes; making a ball-mill; applying glaze; using soluble materials; overcoming difficulties; glazes and slips for specific purposes.....	119

**SECTION III: On Working with Metals**

CHAPTER 1. How to work with sheet metals; tin; pewter; copper, brass, nickel silver and sterling silver; soft soldering; shaping by hammering in a hollow block; how to shape cooking vessels; how to line copper cooking vessels with tin.....	139
CHAPTER 2. On forging iron; making tools; grinding and sharpening tools.....	152

**SECTION IV: On Working with Stone**

CHAPTER 1. How to build an efficient fireplace.....	163
CHAPTER 2. On stone carving; kinds of stone; direct carving; sundials.....	167
CHAPTER 3. Lime mortars; cement mortars; stuccos and plasters.....	173

**SECTION V: On Working with Color**

CHAPTER 1. A brief essay on color; earth colors; spectrum colors.....	177
CHAPTER 2. How to paint in fresco; preparing the wall; preparing the design; preparing the colors; starting the work.....	181
CHAPTER 3. On the art of dyeing with old vegetable dyes; preparing and dyeing wool; dyeing linens.....	189
CHAPTER 4. On the art of printing on fabric with wood-blocks; dyeing medium; printing; steaming; further experiments.....	200

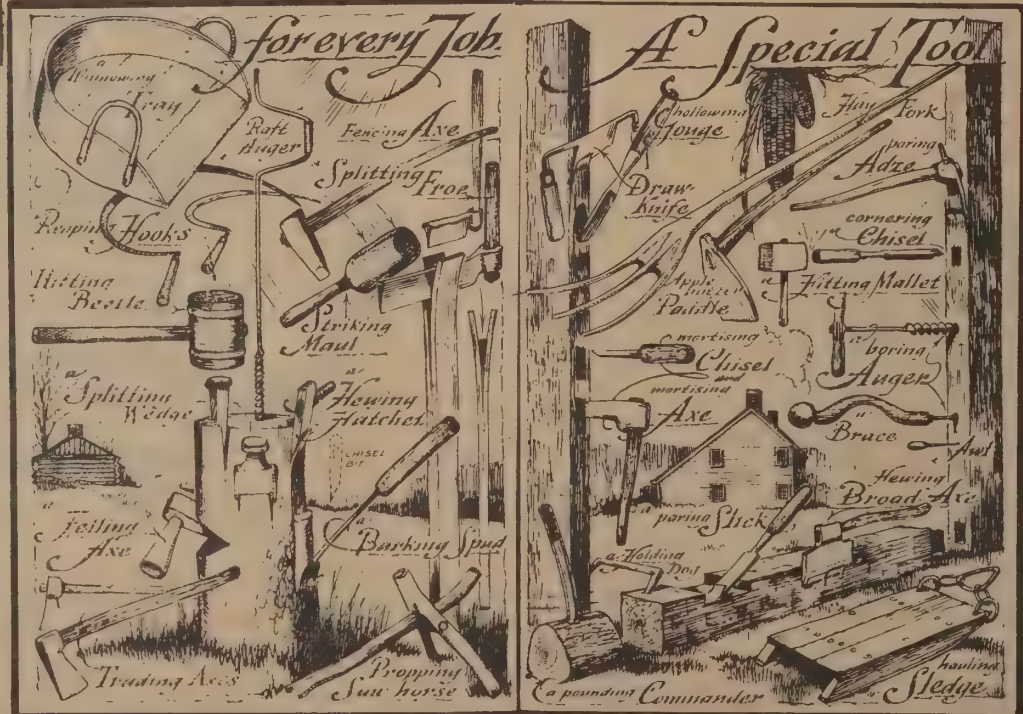

**Allcraft Tool & Supply**

Crafting requires tools specific to the material and the scale you're working with. This is the best supplier we've seen or heard of for craft tools.

[Suggested by ONYX]



Allcraft Tool & Supply Catalog

\$1.00 (refundable with purchase)

from:  
Allcraft Tool & Supply Company, Inc.  
215 Park Avenue  
Hicksville, N. Y. 11801

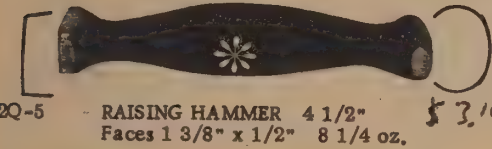

2Q-5 RAISING HAMMER 4 1/2"  
Faces 1 3/8" x 1/2" 8 1/4 oz. \$3.10

**Woodcraft Supply**

Some years ago, a large, dour Scot, Mr. Eaton by name, was trying to teach Boston schoolboys how to cut a clean mortise with machine-made carbon steel chisels. He couldn't, and being a Scot and stubborn, he began to import fine hand tools from across the water. He had to buy more than he needed, and he sold the surplus, reluctantly, from a dark cobwebbed shop on North Washington Street. To his surprise, he found that other craftsmen had also thrown shoddy tools through cellar windows in fits of frustration. North Washington Street has been torn up, and Mr. Eaton has passed on to the great workshop in the sky, but his company has become the Woodcraft Supply Corp., 313 Montvale Avenue, Woburn, Massachusetts 01801. It is a unique enterprise that operates contrary to the accepted principles of American business. As any hardware store owner will tell you, no one today will pay \$47.50 for a nickel-plated fitted wood case. You can buy one from Woodcraft - if you are willing to talk about it for an hour and enjoy a good cup of home-brewed tea. Have you ever had your forearm shaved as clean as a baby's with a 1-pound paring gouge? You're not likely to have the experience many other places. The same personal touch is apparent in everything handled by this unusual company. (They sell a German cabinet-maker's bench of polished red beech that is seven feet long, weighs 300 pounds, is fitted with two built-in vises, and would make most furniture companies blush with shame. \$235.) Woodcraft Supply publishes a large-format illustrated 30-page catalog full of tools that you will never see anywhere else. It costs 25 cents, and you will be a rare craftsman if you don't order something after one pass through it.

[Suggested and reviewed by Dr. Morton Grosser]

**Woodcraft Supply Catalog**

\$0.25 postpaid

from:  
Woodcraft Supply Corporation  
313 Montvale Avenue  
Woburn, Mass 01801



No. 020. Adjustable Compass plane. Its flexible bed adjusts for work on either convex or concave surfaces. Mailing weight 5 pounds. \$18.50

All of the above 9 planes are made in Sheffield England.

**CLAMP HEADS**

No. 4791. Clamp head. Fits on edge of any one-inch board to provide a clamp of any desired length. Mailing weight 3 pounds. \$3.25

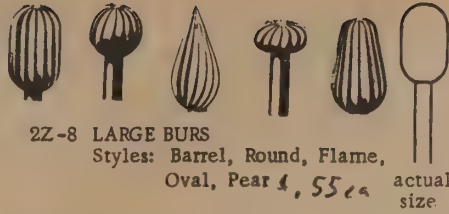
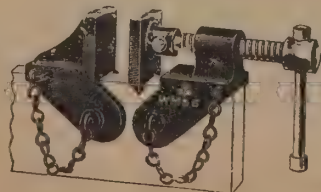

2Z-8 LARGE BURS  
Styles: Barrel, Round, Flame, Oval, Pear, etc. \$5.00 actual size

3M-5 Counter Balance Scale



\$4.50

- SHOP LAYOUTS & KITS.....
- SMALL HAND TOOLS.....
- CASING.....
- SOLDERING EQUIPMENT.....
- POLISHING EQUIPMENT.....
- PLATING, ETCHING.....
- HAMMERS, STAKES, MANDRELS.....
- SHOP EQUIPMENT.....
- FLEXIBLE SHAFT SUPPLIES.....
- CHASING TOOLS.....
- ENGRAVING SUPPLIES.....
- FINDINGS.....
- ENAMELING SUPPLIES.....
- BOOKS.....
- CHEMICALS.....
- LAPIDARY EQUIPMENT.....



**Arts & Crafts**

This catalog looks like it's more for the school trade. Good prices on a wide range of tools and materials.

[Suggested by Mrs. W. B. Mohin]

Catalog free from:  
CCM: Arts & Crafts, Inc.  
321 Park Avenue  
Baltimore, Maryland 21201

**ADJUSTABLE CURVE RULERS**



Instantly adjusts to any desired curve. One ruling edge is raised for ink ruling. Entire rule made of nickel-plated metal. Will bend to circles 8" and up.

- No. 27100 Length 15".....ea. \$2.75
- No. 27101 Length 20".....ea. 3.75
- No. 27102 Length 25".....ea. 4.75

**MOULAGE**



A mold material for taking impressions from life—for reproducing valued antiques when an ancient patina must be preserved, too delicate to submit to being molded in plaster, rubber or gelatine. Moulage will not adhere to anything—molds can be made on human hair or the most delicate skin. Apply warm with brush and palette knife. Captures minutest details. Reuse it approximately 150 times. Complete instructions helps beginners succeed on first project. No. 7678 Moulage, per 2 lb. can.....\$4.95

**L & L ENAMELING KILN MODEL E48**

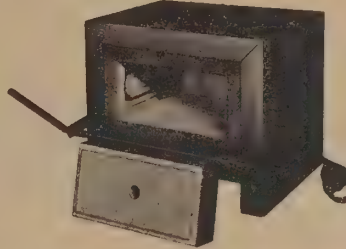

MODEL E48—OPEN

This kiln is designed especially for enameling. Has all the features of the Model E49 with the exception of the pyrometer, input control switch, and counter-weighted door. Can be plugged in on any 110 volt outlet. Inside dimensions 4"x8 1/2"x8".

- No. 8208 Complete.....\$35.00
- No. 8210 Kiln with Copper Enameling Equipment Unit..... 47.50

**CONTENTS**

List of Major Classifications		AIRBRUSH EQUIPMENT & SUPPLIES.....	
CERAMICS & SCULPTURE.....	3 to 48	155 to 156	
CERAMIC KILNS.....	30 to 30	157 to 159	
COPPER ENAMELING.....	49 to 57	160 to 165	
MOSAICS & STAINED GLASS.....	58 to 62	166 to 167	
DRAWING & ART PAPERS.....	63 to 73	CRAFTS: Book, Basketry, Weaving, etc.....	168 to 191
PAINTS & FINISHES.....	74 to 79	LEATHER CRAFT.....	191 to 198
ART SUPPLIES.....	80 to 85	WOOD CRAFT.....	199 to 203
OIL & ACRYLIC PAINTING.....	86 to 99	MINIAT CRAFT.....	204 to 218
WATER COLOR PAINTING.....	100 to 111	LAPIDARY SUPPLIES & EQUIPMENT.....	219 to 220
DRAWING MATERIALS.....	111 to 125	INDUSTRIAL ART EQUIPMENT.....	221 to 228
MECHANICAL DRAWING SUPPLIES.....	126 to 134	MISCELLANEOUS ITEMS.....	229 to 230
ART ROOM FURNITURE & SUPPLIES.....	135 to 134	BOOK SECTION.....	231 to 237
		INDEX.....	238 to 250

**Constantine's Wood Catalog**

Lots of things for woodworking. Prices are high, but if you can't get it anywhere else. . . Lots of fancy woods and finishes. Guitar materials. Fancy cabinet hardware.

[Reviewed by Fred Richardson]

Catalog 84 pp. \$0.25 from:  
Albert Constantine and Son, Inc.  
2050 Eastchester Road  
Bronx, New York 10461

**CLAMP NAILS**



No. 2721 — Style No. 10; Width 5/8". Be sure to state length of nail in ordering.

Length	1/2"	3/4"	1"	1 1/4"	1 1/2"	2"
App. No. per lb.....	330	206	164	140	107	80
Per lb.....	1.32	1.18	1.13	1.13	.90	.90

**CONSTANTINE'S NEW GLUE INJECTOR**

This greatly improved needleless glue injector, made exclusively for Constantine, far surpasses all others. To use, press needleless deep under veneer blister, or drill 1/16" hole into heart of loose joint. Insert long needleless and pressure-force glue by pushing plunger. Needleless squirts glue where nothing else can reach. Pays for itself on first small restoration job. Precision made of aluminum with hardened steel chrome-plated nose. No. 192J11—Postpaid \$2.00 each. \$20.00 per dozen



**CHOICE BRIAR BLOCKS FOR SMOKING PIPES**

Make your own pipe! You can carve a rustic-finish pipe, or you can lathe-turn the smooth style. For popular natural finish of this beautiful briar wood, application of clear-glass high buffing pipe lacquer is recommended. After lacquering, apply polishing compound and buff to high polish on buffing wheel.

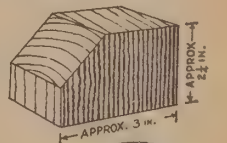

BRIAR BLOCK size R-2 1/4 for bents or straight. No. 108 x 202 Each, \$1.30; Two Blocks, \$2.50 Sh. wt. 8 oz.

STRAIGHT BITS. Most popular style. Narrow bit; doesn't roll. Hard rubber. 11/16" diam. Length 3" shank.

No. 108 x 203 Bits, each 30¢; Two for 50¢ Sh. wt. ea. 5 oz.

PIPE LACQUER 1 pint \$1.25 Sh. wt. 2 lbs.

Bridge, G23 Rosewood 1/2 x 1 1/4 x 8. (Wood only. Not shaped or finished.) Wt. 1 lb. ....\$ .45

**Frank Mittermeier**

Fine carving, sculpting, and engraving tools

[Suggested by Jerome Skuba]

Catalog free from:  
Frank Mittermeier, Inc.  
3577 East Tremont Avenue  
Bronx, N. Y. 10465



Spoon Chisel No. 103 Width from 2 to 10 mm.....each \$1.95



Woodcraft Supply Corp.  
313 Montvale Ave. Woburn, Mass 01801  
Catalog No. 43 1968-1969

## ★ Pottery

Authoritative and scrupulously organized with concise explanations accompanied by 388 lucid photos, Pottery presents an exceptional technique of throwing.

The rudiments seem preferable to those redundant techniques I learned. In addition are many finer techniques I never thought of.

Teach yourself to throw with this book or use it as I would to cleanse myself of bad habits. This is the only appealing pottery book I have ever seen but it only covers throwing. Who knows of equivalent books on other clay techniques and firing?

[Reviewed by Joe Bonner]

### Pottery the technique of throwing

John Colbeck  
1969; 159 pp.

\$10.00 postpaid

from:  
Watson-Guption  
Publications  
165 West 46th Street  
New York, N.Y. 10036

or WHOLE EARTH  
CATALOG

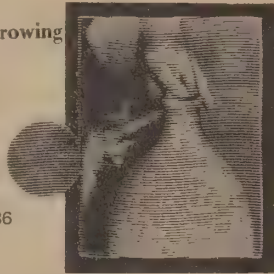

Coiling and throwing has been largely used for making vast storage pots. Pots well over eight feet high have been made by this method. It can equally be used to throw forms which because of their nature could not be made in one piece. The technique is identical.

By far the most convenient method of doing coiling and throwing is to do it on removeable bats. After initial throwing the form should be cut off with a wire and immediately restuck by pressing on the base with the fingers and it should be kept restuck by sponging the untrimmed base. The clay of the initial stage should be dried slowly so that the edge is not too dry and the base not too damp. The clay should be firm but softer than the state at which it would be turned.

Initially the edge is scored and dampened with slip or water or both whichever is preferred.

Then a thick evenly rolled out coil of even clay is placed on the top edge.



The coil is then methodically fingered down on to the form.



When the coil has been fingered down inside and outside and when the join in the coil has been worked over and fingered together, the form can be slowly revolved, pinching the wall up slightly and checking its evenness.

Water is then sponged on to the coil as it is steadied—centred—between the thumb and fingers of the left hand.

The coil can be thinned upwards in a perfectly normal manner. The edge should be firmly steadied. Sometimes it may be necessary to trim the top slightly but if the coil has been evenly made and evenly fingered onto the form this should be unnecessary.

The new wall can then be thrown outwards into a form which would not be possible on a thin open form thrown from one piece of clay.

When very large forms are being made, each new wall developed from successive coils should not be made inappropriately thin for the size of the whole form.

Variations of the technique are possible. A much larger coil than shown can be added. Two or more coils can be added at a time provided they are well fingered together and pinched into a homogenous mass before any throwing begins.

Throwing should always be done in the minimum possible time so that the existing firm clay does not begin to soften and the new clay does not become too soft.

Being softer than the clay under it each successive addition tends to shrink inwards relatively more than the clay under it. This phenomenon has to be seen and experienced to be fully understood and adjustments to form can with experience be made to compensate for it.

52

Coiling and throwing can obviously easily be applied by one person to forms of any diameter.

Centring is done by the logical application of steady firm pressures on the surface of the revolving piece of clay. No great amount of strength is necessary.

The ball of clay should be a neat homogeneous mass and should be firmly placed in the centre of the wheelhead or bat which should be dampened with a wet sponge. The neater this ball of clay is and the closer it is placed to the centre, the quicker and the easier will be the centring process.

A common centring hold and the basic pressures involved are here demonstrated on a small and a medium sized piece of clay.

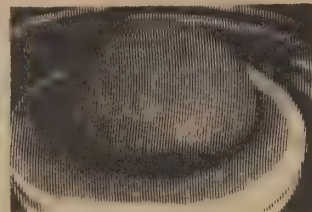

There should be no difficulty in placing smaller pieces of clay centrally on the wheel which can be immediately set in motion. Before either the hands or clay are dampened it is as well with medium sized pieces to check that they are centrally placed and of fairly even form. Any unevenness would be pushed or tapped until the clay is fairly symmetrical.

Two main pressures tend to centre the rotating mass of clay:

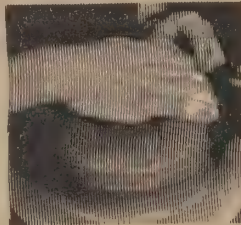

A downward vertical pressure. This pressure is most easily applied by the outside edge of the palm of the right hand. The forearm points to the centre of the wheel and is steadied by resting on the edge of the wheel tray. This pressure exerted alone tends to displace the clay into a wider form.



An inward horizontal pressure. This pressure is most easily exerted by the wrist end of the palm of the left hand. This forearm also points to the centre of the wheel and is steadied by resting on the edge of the wheel tray. This pressure exerted alone tends to displace the clay into a taller form.

In practice these two pressures are only rarely applied singly. Small and medium sized pieces can generally be centred by the simultaneous application of the two pressures.

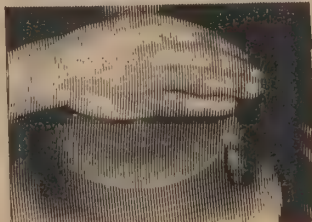

The two pressures isolated in the two previous pairs of photographs are here shown combined. Every opportunity should be taken while centring of achieving additional steadiness through contact of the hands with each other.

There are other centring holds than the one illustrated. All involve an application of the same two pressures.

Throwing is the process of shaping an even mass of soft plastic clay by hand on a wheelhead revolving at speeds varied by the thrower.

Turning is the process of paring away excess clay from a leather hard form.

Trimming with a needle or pin



The revolving wall is gripped lightly between the fingers and thumb of the left hand. The right hand holding the needle is steadied on the left thumb.



The needle is pushed through until it touches the fingers of the left hand.



The left hand then grips the clay slightly more firmly and both hands rise forwards and upwards.

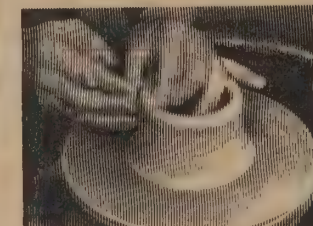
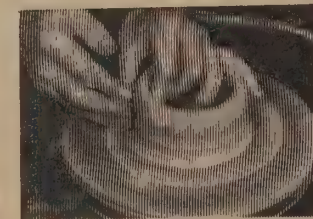

The clay is squeezed between the index finger and any one of the first three fingers of the right hand. This method is used much less frequently than the previous two but beginners do find it useful for gaining additional steadiness. Two variations are possible; if the pressure inside is applied by the ball of the index finger the main pressure can be applied by any one of the fingers and can be varied, the fingers not applying pressure outside can exert a slight steadying pressure to control the form either above or below the main point of pressure; or, if the side of the index finger is used inside pressure can be spread through all three fingers, the point of main pressure usually being in the lowest finger outside and the ball of the inside finger.

## Potter's Wheels

Soldner and Brent sell exceptional potter's wheels. Soldner's is reputedly the best kick wheel made (and he sells a 250 lb. capacity clay mixer for \$500). Brent's look good and are cheap. His kick wheel is "the equal of other wheels costing \$100 more." Brent also sells electric wheels of industrial or school quality (Model C) and student size (Model A) as well as a kick wheel kit. Compare the prices yourself. [Tell us what you learn.]

[Reviewed by Joe Bonner]

### LARGE THROWING HEAD

14" aluminum alloy with concentric centering rings. The casting has been accurately turned on a machinist lathe. Shaft and mounting hole, 1" in diameter.

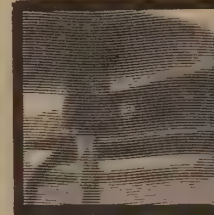

Soldner kick wheel  
\$200 (unpainted)

Brochure  
free

from:  
Soldner/Pottery & Pottery Equipment  
Box 917  
Aspen, Colo. 81611

[Suggested by Jeff Schlanger]

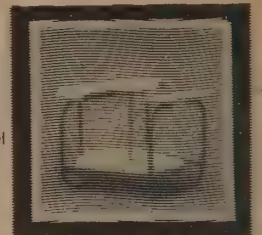

### SELF ALIGNING BEARINGS

1" top and bottom ball bearings. Locking device adds structural support. Standard zerz grease fittings are included for ease in occasional maintenance.

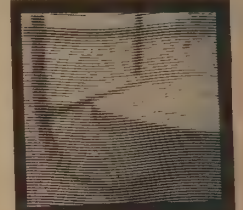

### CONCRETE FLYWHEEL

Reinforced concrete flywheel of about 90 pounds, 30" in diameter. The underside is cuffed to move dead weight from the center to the rim for maximum centrifugal effect. The concrete "tooth" provides an excellent permanent kicking surface. Height of the flywheel is adjustable. Heavier weight flywheel is available upon request.

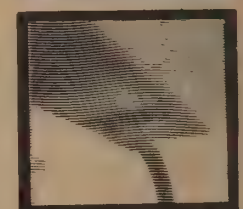

### ADJUSTABLE SEAT

Both height and angle of the seat can be changed to accommodate individual preferences. 1" x 8" x 24" exterior plywood is both sturdy and comfortable.

### SAFETY FOOT RESTS

2" x 3" angle irons completely cover the top of the flywheel for safety and sure footing. An additional 2" guard protects the exposed back edge of the flywheel. Height of foot rests are adjustable.

★ Robert Brent Potter's Wheels are only sold direct to the customer. If the Model C, for instance, were sold through ceramic suppliers, it would cost \$350-\$400 as do other wheels of comparable power and quality. We have simply eliminated the middle man and sell direct at essentially the wholesale price. You cannot get more for your money in a potter's wheel anywhere.

### PRICES

	HP	Speed	
Model A	1/4	40-150	\$139.00
Model C	1/2	0-220	\$235.00
Kick Wheel			\$ 79.50
Kick Wheel Kit			\$ 35.00

### Brochure free

from:  
Robert Brent Potter's Wheels  
1101 Cedar Street  
Santa Monica, Calif. 90405

[Suggested by Mary Crawford]

### MODEL A

It has a 1/4 horsepower, 2 speed motor powerful enough to center 15 to 20 pounds of clay.

There are other potter's wheels available at lower prices than the Robert Brent Model A, but none offer all of the necessary features of this wheel: full sized cabinet, motor, switch and cord, foot pedal, 12 inch head, and ball bearing construction. It is ready to plug in and use when it arrives, and will last for years and years, even in constant use, without wear and without attention. It is the finest low priced potter's wheel available.

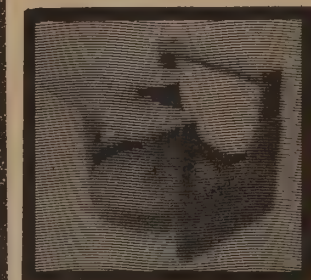

### MODEL C

The motor delivers a peak output of over 1/2 horsepower for centering the largest pots. 75 or 100 pounds can be centered without stalling the wheel.

Motor speed is controlled with a heel and toe foot pedal which will hold any speed when your foot is removed and goes right to zero when tilted all the way back.

This is an ideal potter's wheel for use in schools, where hard daily use is expected. It is virtually maintenance free (the motor brushes need to be checked yearly and replaced when necessary), and can be run all day without strain.

### KICK WHEEL

The flywheel, also made of 1/2 inch ply, exterior grade, is a hollow sandwich structure which is so rigid that a grown man can stand on its edge without harm. The flywheel weighs 35 pounds empty, and can be filled through four holes in the top with up to 100 pounds of gravel. Thus the weight of the flywheel may be varied to suit the individual potter. 2X4 sections inside the flywheel prevent the shifting of gravel and keep the flywheel perfectly balanced.

**Metal Techniques for Craftsmen**

If you read this book, you'll know more about metalworking than just about anybody you know. International in scope, it covers an incredible collection of techniques from many countries and cultures. The various techniques are presented with a complete set of instructions for each one and are illustrated by excellent photographs, often of native craftsmen doing their thing. Tools are described and illustrated in detail. Everything is described in detail. Reading this book will take you right up to that point where you'll have to do it awhile yourself to get into it any further. This is a real assembly of diverse information some of it hard to find, and a metal-crafter-jeweller should be into new things within an hour of getting his hands on it. This is one of those rare and super books written by someone that wanted to lay his trip on others. Well worth the money. The "definitive text" as they say.

[Suggested by Claudio Marzollo. Reviewed by Jay Baldwin]

**Metal Techniques for Craftsmen**  
Oppi Untracht  
1968; 509 pp.

**\$19.95** postpaid

from:  
Doubleday & Co.  
501 Franklin  
Garden City, N. Y. 11531

or **WHOLE EARTH CATALOG**



Greek bronze wire fibula, "spectacle type," tenth-eighth centuries B.C. (Geometrical Period). Back view. Length: 5 5/16 inches. This pin, including the pinstem and catch, is made entirely of one continuous piece of wire. Metropolitan Museum of Art, New York. Fletcher Fund, 1937.

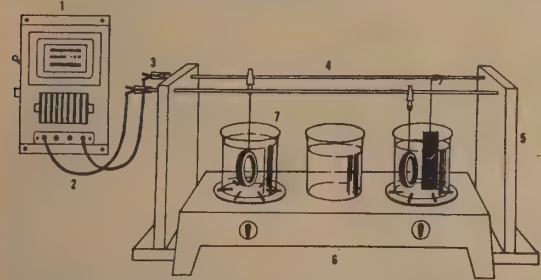

Electroplating and electroforming equipment: a simplified arrangement for small scale use by craftsmen: 1. Selenium rectifier. 2. Anode and cathode wire. 3. Electrician's clips. 4. Bus bars. 5. Wood bus bar rack. 6. Electric hotplate, two burner. 7. Pyrex glass beakers: the first contains the article suspended from the anode bus bar for cleaning, the second is for rinsing, the third is the plating beaker with the anode plate and the article suspended from the cathode bar to be plated.

**Saunders Casting Equipment and Supplies**

This catalog looks to have everything you'd need to get into casting and mold making. The equipment you would need for any process is listed and described. No prices are given, but the company is obviously not a discount house. A person thinking about getting into casting metal could learn a lot just by looking at this catalog.

Catalog [Reviewed by Jay Baldwin]

free from:  
Alexander Saunders & Co., Inc.  
P. O. Box 265  
Cold Spring, N. Y. 10516

**Gem Guild**

It looks like they have nice stuff. I have no idea as to their reputation. They do have rare things to sell, and the catalog appears to be of the sort one finds printed by nuts in the field who know and love their bag.

The **Very Rare** [Suggested by Carol Guyton Goodell. Reviewed by Jay Baldwin]

#12.00 100 PARCEL  
#20.00 200 PARCEL

**GEM SPENS-URITE GARNET:** The queen of garnets in perfect stream-polished crystals almost perfect in shape. 5 CARAT PARCEL.  
**RARE GREEN QUARTZ:** Starting "ground" material from Brazil. 12 CARAT PARCEL.  
**IMPERIAL LAPIS LAZULI:** Splendid, intense royal blue, and clear. Afghanistan. Well shaped and scorable pieces. 20 CARAT PARCEL.  
**GEM RHODOCHROME GARNET:** Stream polished crystals of the finest grade. 9 CARAT PARCEL.  
**MASSACHUSETTS DATOLITE:** Fine facet sections of crystal. Rare. 15 CARAT PARCEL.

Catalog

free

from:  
The Gem Guild  
Box 713  
Mill Valley, CA 94941



A craftsman of Tanjore, India, securing an encrusted silver ornamental medallion on a brass plate in the "nagas" or "swami" process of metal decoration.

**SAND CASTING OF ALUMINUM.** Sand casting is the best-known and most frequently used casting process. (For a procedural discussion, see page 325.) The method used for aluminum is the same as that used for other non-ferrous metals, with care taken for temperature control. In small sand castings, a section of 3/16 of an inch is considered the minimum possible. The surface of sand castings depends for its character on the fineness of the sand used. For large castings, coarser sand is advisable. Aluminum sand castings generally have smoother surfaces than other sand cast metals, partly because of the lower melting point required of the metal, and partly because the sand does not burn into the surface of the casting.

Forge welding is the oldest welding process. Wrought iron and mild steel can be welded in forging by heating the parts to be joined till they are brilliant white-hot and emitting sparks. The metal at this point has reached a condition of surface plasticity. The parts are then brought into contact quickly, on top of each other, and hammered together. They fuse into one unit. Butt joints can be welded by first upsetting the ends to be joined, to thicken them, then reheating the ends to welding temperature, placing them together, and hammering them. The original thickness is maintained. If the metal is absolutely clean, free of oil or cinder, no flux is necessary, because the slag in wrought iron acts as a flux. The force to be exerted by the hammer depends on the mass and size of the parts being joined.

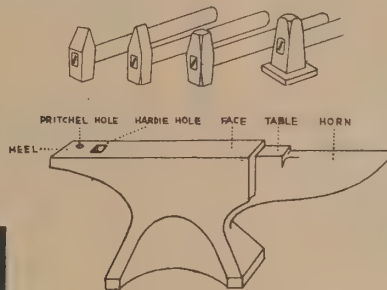

Sterling silver necklace utilizing 18-gauge metal, by Mary Ann Scherr. Length: 16 1/2 inches; each unit: 3 1/2 inches by 1/2 inch. The intaglio pattern was created with an etching solution of half nitric acid and half water and was then oxidized.



**GENERAL TOOLS AND SUPPLIES (NEW YORK)**

- Allcraft Tool and Supply Co., Inc., 15 West 45th Street, New York, N. Y. 10036
- Anchor Tool Co., 12 John Street, New York, N. Y. 10007
- Craftool, Inc., 396 Broadway, New York, N. Y. 10013
- Gamzon Bros., 15 West 47th Street, New York, N. Y. 10036
- Paul H. Gesswein & Co., Inc, 235 Park Avenue South, New York, N. Y. 10003
- I. Shor Co., Inc., 64 West 48th Street, New York, N. Y. 10036
- Standard Diamond Tool Co., Inc., 71 West 47th Street, New York, N. Y. 10036
- John Sells and Sons, 66 West Broadway, New York, N. Y.

**EASTERN STATES EXCEPT NEW YORK**

- Craft Service, 337-341 University Avenue, Rochester 7, N. Y.
- Tools and Supplies William Dixon, Inc., 32 East Kinney Street, Newark 1, N. J.
- Tools and supplies American Handicrafts Co, 45-49 South Harrison Street, East Orange, N. J.
- T. B. Hagstoz & Son, 709 Sansom Street, Philadelphia 6, Pa.
- B. A. Ballou and Co., Inc., 61 Peck Street, Providence, R. I.
- Jewelry findings Capitol Tool and Findings Co., Inc., 100 Delaine, Providence 9, R. I.
- W. R. Cobb Co., 101 Sabin Street, Providence, R. I.
- Jewelry findings Manin Jewelers Supply Co., Inc., 373 Washington Street, Boston 8, Mass.
- C. W. Somers Co., 387 Washington Street, Boston-8, Mass.
- Jewelry supplies General Findings, Inc., Attleboro, Mass.
- Jewelry findings in all metals Arts and Crafts Distributors, Inc. (Showroom and Service Center) 9520 Baltimore Avenue, College Park, Md.
- Bergen Handcraft Supplies, 300 S. W. 17th Avenue, Miami, Fla.

**MIDWEST AND SOUTH**

- Brodhead Garret & Co., 4560 East 71st Street, Cleveland 5, O.
- Tools and supplies Ohio Jeweler's Supply, Inc., 1000 Schofield Building, Ninth and Euclid Ave., Cleveland 15, O.
- Snapvent Company, 1107 West Cumberland Avenue, Knoxville, Tenn.
- Tools and supplies C. R. Hill Co., 35 West Grand River, Detroit 26, Mich.
- Metals and tools Bartlett & Co., Inc., 5 South Wabash Avenue, Room 819 Chicago, Illinois
- Small tools, and jewelry supplies The Jewelry Craftsman Co., 139 North Wabash Avenue, Chicago 2, Ill.
- Findings Ernest Linick Co., 5 South Wabash Avenue, Chicago 3, Ill.
- Jeweler's supplies C. and E. Marshall Co., 1445 West Jackson Boulevard, Chicago, Ill.
- Sax Crafts, 1101 North 3rd Street, Milwaukee, Wis.
- Metals, tools and findings Gagers Handicraft, 1024 Nicollet Avenue, Minneapolis 3, Minn.
- Tools Norvell Marcum Co., 223 East Third, Tulsa 3, Okla.
- Hand tools, jeweler's supplies New Orleans Jeweler's Supply Co., 208 Chartres Street, New Orleans, La.
- Southland Jeweler's Supply Co., 213 Baronne Street, New Orleans, La.

**WEST**

- Baker Platinum (Division of Engelhard Industries), 760 Market Street, San Francisco, Calif.
- Jeweler's supplies, findings and metal Miller Tool and Supply Co., 1044 Folsom Street, San Francisco, Calif.
- Nordman & Aurich, 657 Mission Street, San Francisco, Calif.
- Tools, jeweler's supplies and findings Williams & Peterson, 130 Geary Street, San Francisco, Calif.
- J. J. Jewelcraft, 2732 Colorado Boulevard, Los Angeles 41, Calif.
- Jeweler's and lapidary's tools and supplies Grieger and Co., 1633 East Walnut Street, Pasadena 4, Calif.
- Tools and supplies, lapidary equipment L. A. Clark Co., 1417 4th Avenue, Seattle, Wash.

[Untracht also lists sources for power tools, chemicals, gems, abrasives, casting supplies, welding supplies, foundries, wood, plating equipment. Also British suppliers.]

**Adhesive Products**

Silicone molding rubber (cast anything!) at low prices & Monzini epoxy based casting compounds. 20th Century materials.

[Suggested and reviewed by Jeff Schlanger]



Brochure & pricelist

free from:  
Adhesive Products Corp.  
1660 Boone Avenue  
Bronx, N. Y. 10460

1 1/2 Pt. Kit (1 1/2 lbs.)  
Consisting of 1 lb. ADRUB RTV and 1/2 lb. ADRUB RTV Rubber Hardener \$ 6.00

**4530 MONZINI IRONZINI**

5 gallons \$ 50 per pound  
1 gallon .60 per pound

## Macramé, the Art of Creative Knotting

The craft of knotted lacemaking has long been practiced by sailors passing lonely hours making belts and fringes for folk back home, by nuns devising decorations for ecclesiastical vestments and altar cloths, and by indigenous peoples working ornamentation on their costumes. Although designs for knotted pieces differ according to locale and use, there are very few individual knots. Virginia I. Harvey has collected photographs of traditional knotted pieces throughout the world and presents them in a book called *Macramé, the Art of Creative Knotting*. She carefully diagrams the half-knot, square knot, double half-hitch, diagonal double half-hitch, vertical double half-hitch and other knots. The basic knots are described in detailed instructions for making a sampler. Following the pattern for the sampler will give the beginner experience in doing the knots, and show how combining just a few types of knots can offer large pattern variation. Those willing to suffer through the tedium of learning a few basic knots by duplicating the sampler undoubtedly will find enjoyment in seeing a design grow out of a few lengths of string, besides having a pleasant tactile experience. If not, macramé is not the craft for you.

This book is the best reference manual of knotting technique available. It offers information on all facets of macramé, including discussion on planning, mounting, shaping and finishing a knotting project. Tools and materials are displayed. There are photos exhibiting how different fibers worked in the same pattern can vastly alter visual and textural effects. The pictorial history of macramé and examples of contemporary knotting projects offer plenty of design ideas for more advanced macramé craftsmen.

Knotters interested in explicit directions for traditional macramé purses can obtain patterns by sending \$1.10 to: Pasch Art Studio, 28 Colonial Parkway, Dumont, N. J. 07628 with a request for "Macramé Bags," Booklet A.

[Reviewed by Sue Boyle.  
Suggested by Alexandra Jacopetti]

**Macramé, The Art of Creative Knotting**  
Virginia I. Harvey  
1967; 128 pp.

\$8.50 postpaid

from:  
Van Nostrand-Reinhold Co.  
450 West 33rd Street  
New York, N. Y. 10001

or WHOLE EARTH CATALOG

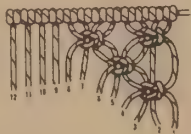

54

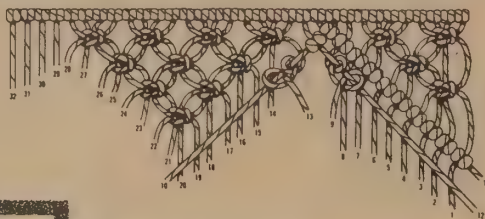

## Dye Plants and Dyeing

This book I consider about the best that is available on its subject and would make an excellent basic handbook for the beginner. It contains historical information as well as the basic steps to dyeing, recipes, and articles about dye plants from various regions and countries. So, no matter what part of the country you live in, you will find a variety of plants and recipes which you would be able to use. There is enough information in this book which should enable you to start your own dyeing and end up with satisfactory results... which is not true of all natural dye books. The one difficulty in using it, however, is that there is no index.

[Reviewed by Carole Beadle]

**Dye Plants and Dyeing**  
100 pp.

\$2.50 postpaid from:  
Brooklyn Botanic Garden  
Brooklyn, N. Y. 11225

or WHOLE EARTH CATALOG



How to prepare the dye solution by chopping, then soaking and boiling the plant parts, and straining them out before adding their color to the dye bath, is told on pages 13 and 14. Briefly, here are the basic directions for the actual dyeing of wool:

- Have wool clean and moist.
- For each pound, use 4 to 4½ gallons of dye bath.
- Enter wool when dye bath is lukewarm.
- Heat slowly to simmering point and let simmer half an hour (longer if required), moving wool gently back and forth.
- If dye bath gets low, lift wool, add hot water, mix in well, and return wool to pot.
- Rinse dyed wool first in nearly boiling water, then in several waters of gradually lowered temperatures.
- When rinsing water is clear, squeeze moisture out of wool and dry in shade.



**Bloodroot**  
Fruits of the native elderberry (*Sambucus nigra*) will give lilac blue with an alum mordant, violet purple with chrome. The leaves alone give various tones of yellow, according to the mordant.

## The Complete Book of Progressive Knitting

This is the most complete knitting book that I have seen. It discusses yarn, its qualities and history, and gives clear instructions on the basics of knitting. Where other books only give directions cryptically written as "K1, \*Y.O., K2 together \*K1 repeat this row for the desired no. of rows," this book tells you how to figure out the desired number of rows for all types of garments from sweaters to suits. The only real drawback I could see was the book's illustrations.

**The Complete Book of Progressive Knitting**  
Ida Riley Duncan  
1966; 386 pp.

\$5.95 postpaid

from:  
Liveright Publishing Corp.  
386 Park Avenue South  
New York, N. Y. 10016

or WHOLE EARTH CATALOG

Buttonholes are knitted as the fabric is being made, not slashed as in sewing. Therefore, it is advisable when knitting garments, to knit the side on which the buttons are to be fastened first. In this way the position of the buttons may easily be ascertained and marked, and hence be a guide for the buttonholes. This is important especially where the last buttonhole should be at the neck line. Decide upon the size of the button. If bands are used, the buttonhole is made in the center of the band. The width of the band usually depends upon the size of the buttonhole, that is, if a buttonhole requires 4 stitches, the band should be at least 8 stitches wide, allowing ½ the width of the button on each side of the buttonhole.

Method. The position and size of each buttonhole having been ascertained, bind off the necessary number of stitches at this point. Continue to complete the row as previously, and back again to where the stitches have been bound off. The stitches are added the same way as the second method in the Chapter on Fundamentals.

Note. Turn the work to the wrong side to add the stitches and back again to the right side after they have been added.

After the garment is completed, the buttonholes should be finished with buttonhole stitches, using the same yarn if possible, or should be reinforced with binding on the wrong side.

Garments of pure wool yarns are hard to ignite even with an open flame, because wool is slow to oxidize. This is a great protection in the home, especially where there are young children.

Wool may be knitted or woven into fabrics of delicate sheerness, unsurpassed by any other fiber, and lightness is one of the essentials of modern attire.

**B. Armhole Formation**  
The shoulder to shoulder measurement is 18½ inches.  
15½ x 6 sts to the inch = 81 sts.  
An even number of stitches is always better in calculating any change of shape in knitting, therefore we shall use 80 sts for the required number across the shoulders.

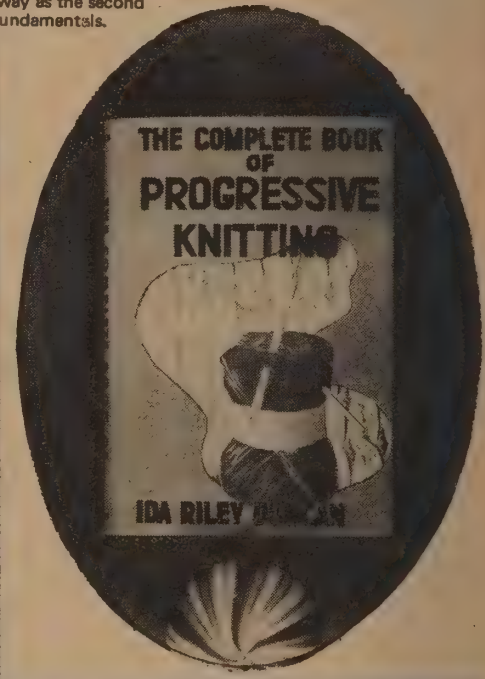
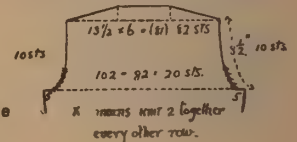

[Who knows the best sources for dyes?]

## The Indian Spinner

If you are looking for an interesting new type of spinning wheel which is relatively inexpensive compared to the standard antique or new wheels, consider an "Indian Spinner". They are much easier to learn to spin on, especially if you can spin yarns with a spindle. The nicest feature is the ability to handle very thick yarns as well as the thin threads you get with a standard wheel. Its design is simple and functional, being similar (if you are familiar with the parts of a spinning wheel) to that of an enlarged "mother-of-all" of the standard wheel. The Bobbin holds a great amount of yarn. The spinner head can be attached to an old type treadle sewing machine or purchased with a wood treadle to match the spinner. The Spinner Head alone costs about \$25, with a treadle base \$43.50. These prices are for the plywood spinners; they also come in fancier woods at fancier prices. They are available through the Handcraft House, 1942 Marine Drive, North Vancouver, B.C., Canada. They publish a small catalogue for \$5.00.

[Suggested and reviewed by Carole Beadle]



**Bloodroot Red**  
(*Sanguinaria canadensis*)

The rhizomes ("roots") which are used for dyeing contain a reddish-orange juice which was widely used by American Indians. A large leaf and single flower make the plant conspicuous in spring. Mordant: Alum.  
To prepare the dye: Cut 8 ounces of fresh roots into small pieces, soak an hour, then boil 30 minutes. Strain liquid into bath for dye.  
To dye: Heat dye bath until lukewarm. Enter the mordanted, wetted wool. Continue heating slowly and simmer until the desired color is obtained. Rinse thoroughly and dry in shade.

**Leclerc Loom**

Leclerc Industries offers a large catalog of weaving accessories & looms of all types and sizes. Highly recommended by owners & users (these looms are found in the weaving depts. of many schools).  
[Suggested by Janet Grosser]

Free catalog from Leclerc Industries P.O. Box 267 Champlain, N. Y.



**Pioneer Loom**

A breakthrough. Table looms 10", 15", or 20"; available with 2,4,6 or 8 harnesses. A unique warping system which saves time and permits great flexibility in design. Since the heddles & reed are open, and the frame is extendable, the warp can be one continuous thread taken from a ball of yarn. The usual warping sequence is simplified into one operation that takes only minutes to complete. No extra equipment is needed; the loom itself can displace warping board, lease sticks, hook & raddle.

Because the warp can be one continuous thread (or several continuous threads used alternately), design can occur spontaneously without previous exacting calculations. Warp threads can be adjusted from one dent to another & from one heddle to another even after weaving has begun.

Why haven't looms always been made like this?

Prices range from \$94.50 for 10" 2-harness "Sampler" to \$169.50 for 20" 8-harness "Craftsman."

[Suggested by Rose Sargant. Reviewed by Sarah Kahn]

Loom or additional information from:

Craft & Hobby Book Service  
Box 626  
Pacific Grove, CA 93950

or

Northwest Looms  
Box 241  
Coburg, Ore. 97401

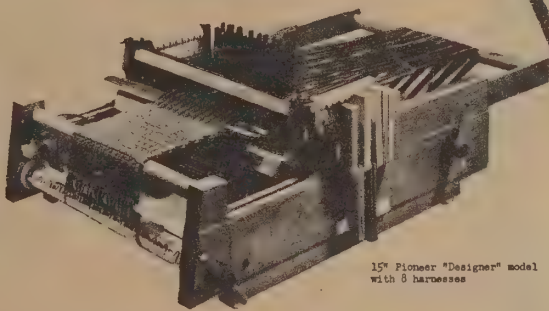

15" Pioneer "Designer" model with 8 harnesses

Additional loom sources suggested by Jerome Skuba

Handcrafters  
521 West Brown Street  
Waupun, Wisconsin 53963

Norwood Loom Company  
Box 272  
Baldwin, Michigan 49304

Bailey Manufacturing Co.  
118 Lee Street  
Lodi, Ohio 44254

**Condon Woolen Mills**

Excellent source of high quality 100% virgin wool yarn available in broad range of colors and sizes for use in weaving, knitting, crocheting, rug hooking, afghans. Yarn sizes include 1-ply single for weaving and knitting fine garments, 2-ply fine & medium, 3-ply, and 5-ply bulky for rug hooking, heavy sweaters. Of special interest to color-fiends: Condon offers several yarn colors which are not to be found anywhere else. Service is good—West Coast orders usually arrive in a week. Prices including duty are \$3/lb natural colors, \$3.20/lb dyed.

[Reviewed by Sarah Kahn]

Color cards

free

from:  
William Condon & Sons Woolen Mills  
P. O. Box 129  
Charlottetown, P.E.I.  
CANADA

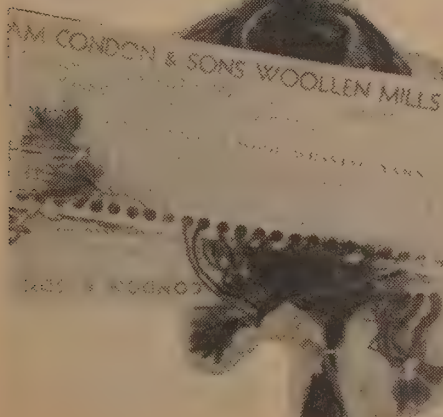

PETER COLLINGWOOD

**The Techniques of Rug Weaving**

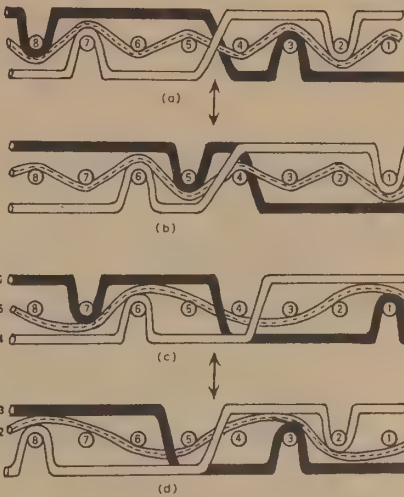

Fig. 293 Block Weaves based on Three-Weft Double-Faced Weaves. (a) and (b) Cross-sections of picks in Fig. 292(a) (c) and (d) Cross-sections of picks in Fig. 292(c)

Fig. 106 Kilim. Weaving an oval

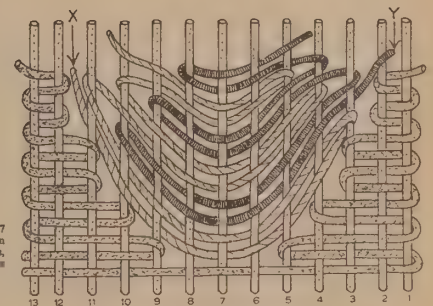
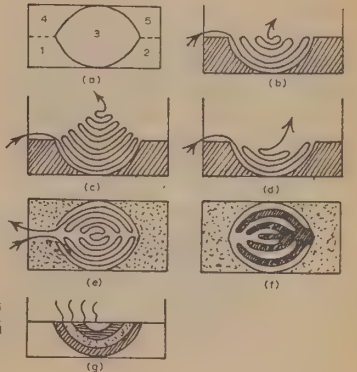

Fig. 107 Kilim. Weaving an oval with two wefts, detailed view

**The Techniques of Rug Weaving**

Peter Collingwood  
1968; 480 pp.

\$17.50 postpaid

from  
Watson-Guption Publications  
165 West 46  
2160 Patterson Street  
Cincinnati, Ohio 45214  
or  
WHOLE EARTH CATALOG



**CUM Yarn Samples**

Though one can stockpile free & usually mediocre yarn catalogs, \$3 sent to CUM brings a large binder filled with sample-cards of handweaving yarns of finest quality, large color range, yet cheaper than dime-store knitting worsted.

CUM is now set up to handle U.S. orders; their catalog/price list is in English, gives price per pound in dollars unlike other European yarn houses. Samples include 1 & 2-ply woolen yarn, rug, tapestry & knitting yarns, 2/20 worsted, cotton & linen yarns, rug warps, twine. All yarns are mothproofed; prices average less than \$3/lb. for yarns of high quality, esthetically and structurally. Orders answered promptly; delivery time approx. 6 weeks by ship, less than 2 weeks by air.

Catalog and Binder of samples

\$3.00 postpaid

from  
CUM Textile Industries, Ltd.  
Rbmersgade 5  
1362 Copenhagen K  
Denmark



[Reviewed by Sarah Kahn]

**★ Naz-Dar Silk Screen Materials**

Probably the most complete source of screen processing materials for printing on almost everything but soft butter. While intended primarily for the commercial market, Naz-Dar's catalogue will give you an insight into this practically unlimited medium.

[Reviewed by Carl Mueller.  
Suggested by Jerome Skuba]

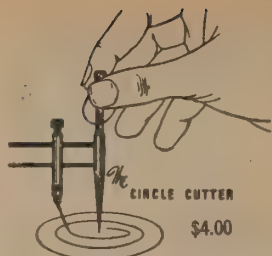

**Naz-Dar Catalog free**

from:  
The Naz-Dar Company  
1087 N. North Branch Street  
Chicago, Ill. 60622

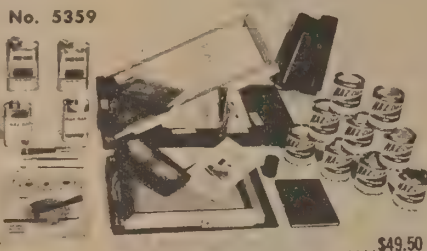

**★ Indian Crafts and Lore**

If Boy Scouts and Germans make better Indian gear than most Indians (it's true: ask at any pow-wow), this book may be why. Thorough research and splendid illustration trip you right on in. Good book.

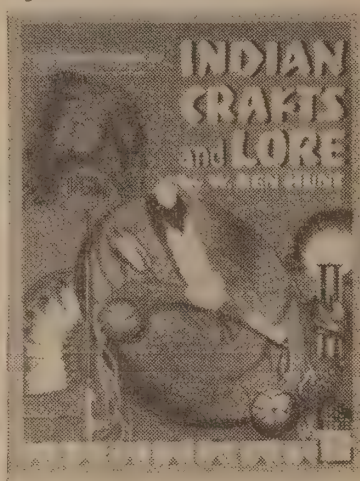

Indian Crafts and Lore  
W. Ben Hunt  
1954; 112 pp.

\$4.50 postpaid

from:  
Golden Press  
Macmillan Company  
Front and Brown Streets  
Riverside, Burlington County  
New Jersey 08075

**Buckskin**

Buckskin in downtown San Francisco costs \$1.50 a square foot; Leather Tanning offers the same material for 95¢/sq. ft. plus shipping (about 10¢/sq. ft.). The buckskin is chrome-tanned, which makes it more resistant to the effects of water than oil-tanned skin. The company also carries cowhide, elk skin, hair-on calf, etc. Orders for a dozen or more skins get 10¢/sq. ft. discount. Buckskins are generally 10-12 sq. ft. in size, calf skins smaller, elk skins larger. The shirt was made of two 12 sq. ft. buckskins.

**Buckskin**

\$ .95 /sq. ft. from:  
Leather Tanning Company  
P.O. Box 2406a  
San Francisco, CA 94124



WOODLAND SHIRT

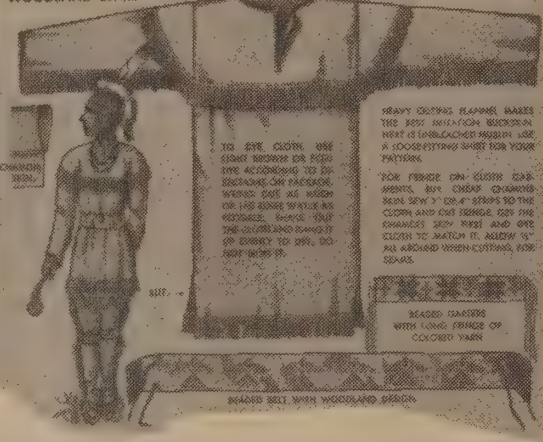

Sonny Strong has passed over the Great Divide, but his way of making rawhide lives on.

This is it: When the hide or skin is taken off the carcass and while the body heat is still in it, spread it out flat with the flesh side up and salt it down with 40 or 50 pounds of fine stock salt. This is for a mature hide. For a yearling or calf skin use half the amount of salt. Spread the salt evenly and fold the hide over so the hair side is out and the flesh sides are together.

Leave the hide in a shady, dry place for from a week to ten days. It is important to salt the hide while the body heat is still in it, Rickman emphasizes. So if you do not actually remove the hide yourself, get the person who does the work to salt it down for you. The salt runs the blood and glue out of the hide before it congeals and Rickman feels this is important in keeping the hide pliable.

PLATE 32. HOW TO TIE THE REATA TO THE HONDA

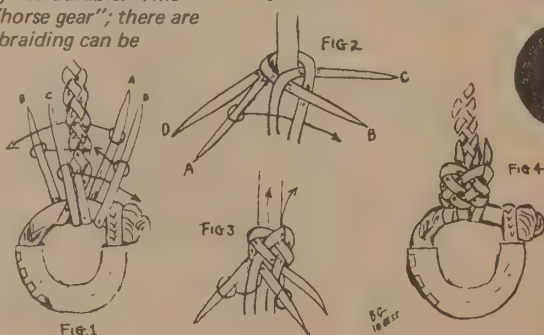

**★ How to Make Cowboy Horse Gear**

A highly practical book on the uses of rawhide. Included is a section on how to cure "green leather" and make your own rawhide. When braided, leather is strong and durable. This book illustrates the use of rawhide for "horse gear"; there are certainly other situations where leather braiding can be used to advantage.

[Reviewed by Mary McCabe.  
Suggested by Gary Snyder]

How to Make Cowboy Horse Gear  
Bruce Grant  
1953; 186 pp.

\$3.50 postpaid from:  
Cornell Maritime Press  
Box 109  
Cambridge, Md. 21613

**56**

**★ Basketry**

Who knows about basketry? What do you think about this book?

Basketry  
F. J. Christopher  
1952; 108 pp.  
\$1.25 postpaid

from:  
Dover Publications, Inc.  
180 Varick Street  
New York, N. Y. 10014

or WHOLE EARTH CATALOG

Space—considerable work space—is needed for the practice of basketry, and it is a rather messy operation because of the necessity for keeping material damp. It is therefore not a craft that can be pursued in a corner of the living room (while looking at television). It also calls for a patient and careful temperament.

Most kinds of reedwork last a very long time, if they are well made in the first place, but naturally they do not stay clean indefinitely. Reed and willow can be brushed or washed in clear warm water. Soap should not be used as it tends to lodge in the cracks. Raffia work can be washed with soap and water. It should be allowed to dry naturally away from a fire, though if it is left out in the sun, it will become slightly bleached.

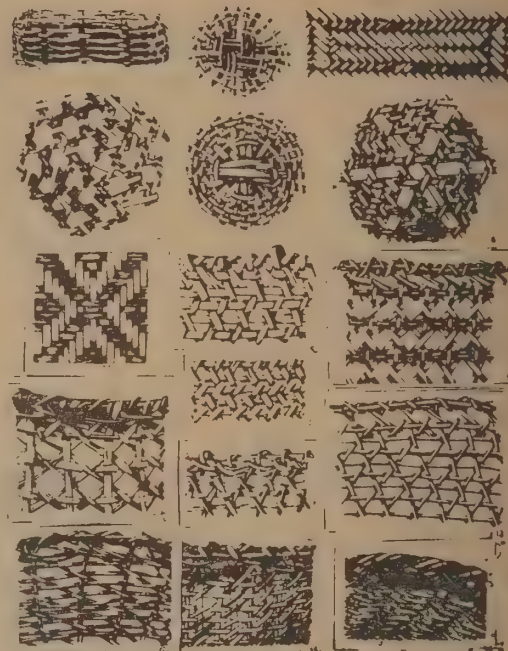

**★ Modern Art of Candle Creating**

There's lots of wimpy books on candle-making, and this is one of them. But it is better than the others—more and wider technique.

**RULES TO REMEMBER**

- To get the most out of your mold, abide by the following rules:
- Never strike it with a hard object.
- Never place it in an oven with a temperature exceeding 175 degrees.
- Never scratch the interior with a sharp instrument or abrasive.
- Never loan to friends unless they know how to care for it.
- Store in a warm, dry place to prevent rust; keep covered to protect interior from dust.
- If you should find it necessary to clean your mold of contaminated or "stubborn wax," use one of these methods:
- Easy Method. Pour your next candle with the wax at 230 degrees. This usually cleans the mold and absorbs stubborn wax.

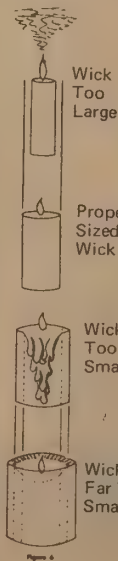

**Modern Art of Candle Creating**

Don Olsen  
1963; 152 pp.

\$6.50 postpaid

from:  
A. S. Barnes & Co.  
Box 421  
Cranbury, N. J. 08512



# Previously listed in Industry and Craft and still beloved:

## How to Build Your Own Furniture

Unlike most books on do-it-yourself furniture, **How to Build Your Own Furniture** by R. J. DeCristoforo contains no plans on how to build your own furniture. What it does contain is information on what should go into the design of a given piece of furniture to make it function properly. If you have ever built a table that wobbled or a drawer that wouldn't open, you will appreciate this book.

The book gives a wealth of information and illustrations on techniques and methods of quality furniture craftsmanship. There are chapters on materials and general design and construction with separate chapters on each of the different categories of furniture (such as tables, chairs, desks, chests, etc.). The book is very concise and the instructions and illustrations are easily understandable. This is definitely a standard work for the designer-craftsman.

[Suggested and reviewed by Lloyd Martin]

**How to Build Your Own Furniture**  
R. J. DeCristoforo  
1965; 176 pp.

**\$3.95** postpaid

from:  
Harper & Row  
49 East 33rd Street  
New York, N. Y. 10016

or WHOLE EARTH CATALOG

## Model & Allied Publications

The British have good how-to books. MAP is a gathering of a passel of them.

[Suggested by Dr. Morton Grosser]

Catalog  
free

from:  
Model & Allied Publications Ltd.  
13/35 Bridge Street  
Hemel Hempstead, Herts  
ENGLAND

## Creative Glass Blowing

This well-illustrated and carefully written book begins with the statement "Any one can learn to blow glass." To a large extent, the authors, one of whom is a professional glass blower, succeed in making that statement believable. However, the first 50 pages are concerned with the tools of the glass blower and I found myself wondering, "Yes, but can anyone learn to be a pipe-fitter, metal worker, carpenter, and electrician?" If you can do those things, there is little doubt that this book (and several hundred dollars worth of tools and related supplies) will enable you to blow glass—probably creatively.

Don't expect to take up glass blowing casually, with just this book, but if it is a hobby to which you can commit yourself seriously this book would be an excellent investment, for starters.

There is a page at the end that lists sources of tools and materials. Unfortunately, there are only a few suppliers mentioned, all of whom are in the East. Alas, we westerners need a special supplement, obviously.

[Reviewed by Richard Raymond]

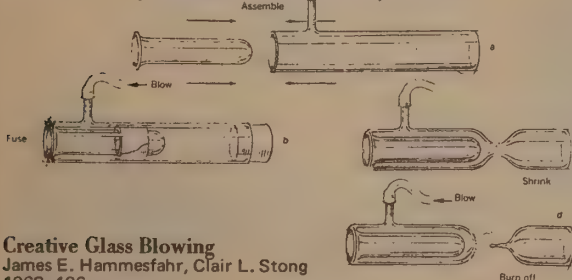

**Creative Glass Blowing**  
James E. Hammesfahr, Clair L. Stong  
1968; 196 pp.

**\$8.00** postpaid

from:  
W. H. Freeman & Company  
660 Market Street  
San Francisco, CA 94104

or WHOLE EARTH CATALOG

## Whittling & Woodcarving

This book was originally published in 1936, but something about it suggests a product of the 19th century. It might bear—unashamedly—the antiquated subtitle, *A Compendium*. It is basically a book of instructions and illustrations (464 of them) about wood carving. Unlike most of the books on carving, it doesn't discriminate between fine arts and folk craft. If you follow Tangerman's instructions you can make anything from a willow whistle to a Renaissance balustrade. The first copy I came across was a tattered red hardbound, and when it disappeared from the elementary school library, I felt a sense of personal loss. In 1962 Dover Publications reissued it in paperback for \$2.00, and if you carve (or would like to), it is a must for your library.

Tangerman begins with some inspiring examples: no less than Grinling Gibbons and Tilman Riemenschneider. He gives a brief introduction to woods, knives and sharpening, and then begins at the bottom with rustic whittling. The mysteries of chains carved from a single block of wood and the ball-in-a-cage are clearly explained in text and drawings. In about 300 pages you are led through chip carving, low relief, high relief, and sculpture in the round, and presumably a lot of chips will have accumulated on the floor by the time you finish the book. At 5½"x8½" it isn't exactly pocket sized, but it will fit in a handbag or a glove compartment with ease. The writing is enthusiastic; it can convince you that if you want to learn to carve, all you need is a sharp knife, a piece of wood, some band-aids, and Whittling and Woodcarving.

[Suggested and reviewed by Dr. Morton Grosser]



**Whittling & Woodcarving**  
E. J. Tangerman  
1962; 293 pp.

**\$2.00** postpaid

from:  
Dover Publications, Inc.  
180 Varick Street  
New York, N. Y. 10014

or WHOLE EARTH CATALOG

## New Science of Strong Materials

Why does glass sometimes shatter and other times bend like a spring? A new field of science involves the study of materials as a whole, rather than in their special chemical, physical, and engineering aspects. Scientists have been investigating the atoms and molecules upon which the mechanical properties of materials depend, and this book is a clear explanation of some of the discoveries being made. Nothing beyond high school math, and a very palatable treatment of an exciting new science.

[Suggested by Steve Baer.  
Reviewed by Lloyd Kahn]

The first thing we discovered was that we could get high strength from almost anything from Epsom salts to sapphire. Provided it was in the form of a thin whisker, it did not matter what the chemical nature of the stuff was or by what method the whiskers were grown. We must have worked on well over a hundred different substances and there was absolutely no doubt about it.

**New Science of Strong Materials**  
J. E. Gordon  
1968; 269 pp.

**\$6.50**

from:  
Walker & Co.  
720 Fifth Avenue  
New York, N. Y. 10019

## Classic Guitar Construction

To build a decent classic guitar, you must make several. The first one should take at least six months in a well-equipped shop with controlled humidity. Special jigs and clamps are required, which you make yourself. The order of craftsmanship and musical sensitivity involved will keep the dilettante out of the picture.

If you've gotten through those gates, then this is really how to do it, no jive. The text and illustrations (including patterns) are elegant, even inspiring. Sloane takes you through all the steps, no gaps, towards a superior instrument. Talk about sacred lines—that's what a classic guitar is made of. It's all conscious decision, a continuous dialogue with the universe.

The book won't talk you into or out of making a guitar. If you're the person, it's your book. Follow Sloane's recipe and the world will beat a path to your door.

[Reviewed by Dave Guard]



**Classic Guitar Construction**  
Irving Sloane  
1966; 95 pp.

**\$5.95** postpaid

from:  
E. P. Dutton  
201 Park Avenue  
New York, N. Y. 10003

or WHOLE EARTH CATALOG

## Plastics

How does a person who becomes interested in plastics find out all there is to know about plastics? One solution may be to spend the rest of your life walking from plastic company to plastic company finding out what each are doing. This would be OK if you were looking for something to do for a long period of time. But if you are longing for a comprehensive review of the world of plastics and/or some good solid reference material on the subject, then I suggest the following three sources.

One is: **Plastics in the Modern World**. It is an interesting little Pelican Original pocket book by two Englishmen; E. G. Couzens and V. E. Yarsley. Part one contains: the Theory and Practice of Plastics which discusses the physical, chemical and behavioral aspects of plastics, while also explaining the manufacturing processes involved in plastics production. Part two of the book concerns itself with the domestic application of plastics and the utilization of plastics by industry.

The **Modern Plastics Encyclopedia** comes with a subscription to **Modern Plastics** magazine, which is technically oriented and interestingly useful. The encyclopedia is by far the most comprehensive text available on the subject of plastics. It analyzes all available plastics, tells you what they can do and where you can get them. It describes the chemical structure of resins and moulding compounds, talks about what's going on in the field of foamed plastics, and describes machinery and methods that are used and available in making products with plastics. Both the magazine and the encyclopedia have free product literature cards at the back of each copy. These can bring you a wealth of detailed information if you desire to study a specific situation very precisely. You can also circle all the numbers on the card and receive a deluge of mail. So have some fun.

[Suggested and reviewed by Michael Rosenthal]

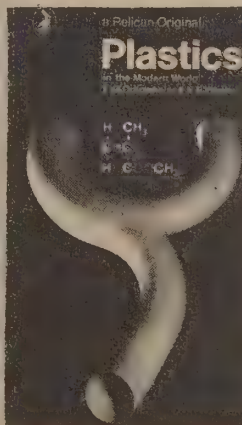

**Plastics in the Modern World**  
E. G. Couzens, V. E. Yarsley  
1941, 1956, 1968; 386 pp.

**\$1.65** postpaid

from:  
Pelican Books  
7110 Ambassador Road  
Baltimore, Md. 21207

or WHOLE EARTH CATALOG

**Modern Plastics**  
(Magazine & Encyclopedia)

**\$10.00** yr. (monthly)

from:  
Modern Plastics  
Fulfillment Manager  
P. O. Box 430  
Hightstown, N. J. 08520

## The Natural Way to Draw

*Drawing is a deeper and wider kind of writing. It's better communication in many ways than writing, and it's much closer to your mind. (The same goes for music and speech).*

*This classic work by an outstanding art teacher is not only the best how-to book on drawing, it is the best how-to book we've seen on any subject.*

[Suggested by Roy Sebern]

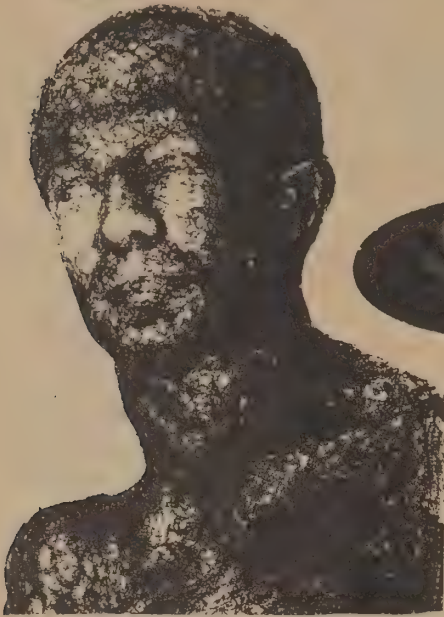

The job of the teacher, as I see it, is to teach students, not how to draw, but how to learn to draw.

YOU SHOULD DRAW, NOT WHAT THE THING LOOKS LIKE, NOT EVEN WHAT IT IS, BUT WHAT IT IS DOING. Feel how the figure lifts or droops—pushes forward here—pulls back there—pushes out here—drops down easily there. Suppose that the model takes the pose of a fighter with fists clenched and jaw thrust forward angrily. Try to draw the actual thrust of the jaw, the clenching of the hand. A drawing of prize fighters should show the push, from foot to fist, behind their blows that makes them hurt.

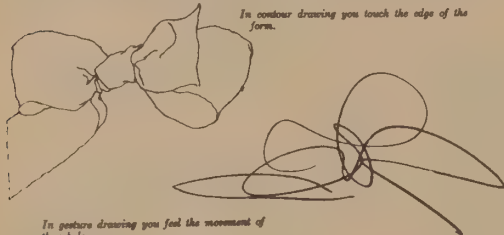

In gesture drawing you feel the movement of the whole.

THE SOONER YOU MAKE YOUR FIRST FIVE THOUSAND MISTAKES, THE SOONER YOU WILL BE ABLE TO CORRECT THEM.

# Communications

The first exercise, which you are about to attempt, is planned consciously to bring into play your sense of touch and to coordinate it with your sense of sight for the purpose of drawing.

Look at the edge of your chair. Then rub your finger against it many times, sometimes slowly and sometimes quickly. Compare the idea of the edge which the touch of your finger gives with the idea you had from merely looking at it. In this exercise you will try to combine both those experiences—that of touching with that of simply looking.

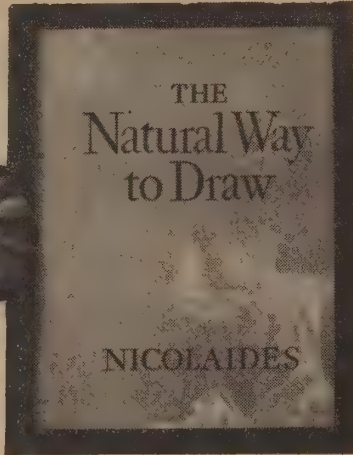

**The Natural Way to Draw**  
Kimon Nicolaides  
1941; 221 pp.

**\$6.00** postpaid

from:  
Houghton Mifflin Co.  
Wayside Road  
Burlington, Mass. 01803

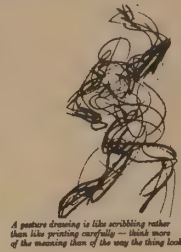

A gesture drawing is like scribbling rather than like printing carefully—think more of the meaning than of the way the thing looks.

### Exercise 1: Contour Drawing

**Materials:** Use a 3B (medium soft) drawing pencil with a very fine point (sharpened on sandpaper) and a piece of cream-colored manila wrapping paper about fifteen by twenty inches in size. Manila paper usually comes in large sheets which may be cut into four pieces of that size. You may use, also, the kind sold as "shelf paper" provided it is not glazed. Fasten the paper with large paper clips to a piece of prestwood or a stiff piece of cardboard. Wear an eyeshade. Do not use an eraser until you come to Exercise 28.

Sit close to the model or object which you intend to draw and lean forward in your chair. Focus your eyes on some point—any point will do—along the contour of the model. (The contour approximates what is usually spoken of as the outline or edge.) Place the point of your pencil on the paper. Imagine that your pencil point is touching the model instead of the paper. Without taking your eyes off the model, wait until you are convinced that the pencil is touching that point on the model upon which your eyes are fastened.

Then move your eye slowly along the contour of the model and move the pencil slowly along the paper. As you do this, keep the conviction that the pencil point is actually touching the contour. Be guided more by the sense of touch than by sight. THIS MEANS THAT YOU MUST DRAW WITHOUT LOOKING AT THE PAPER, continuously looking at the model.

Exactly coordinate the pencil with the eye. Your eye may be tempted at first to move faster than your pencil, but do not let it get ahead. Consider only the point that you are working on at the moment with no regard for any other part of the figure.

**TWO TYPES OF STUDY.** The way to learn to draw is by drawing. People who make art must not merely know about it. For an artist, the important thing is not how much he knows, but how much he can do. A scientist may know all about aeronautics without being able to handle an airplane. It is only by flying that he can develop the senses for flying. If I were asked what one thing more than any other would teach a student how to draw, I should answer, "Drawing—incessantly, furiously, painstakingly drawing."

Probably you realize already that contour drawing is of the type which is to be done "painstakingly." On the other hand, gesture drawing, which you will begin today, is to be done "furiously." In order to concentrate, one can act furiously over a short space of time or one can work with calm determination, quietly, over a long-extended period. In learning to draw, both kinds of effort are necessary and the one makes a precise balance for the other. In long studies you will develop an understanding of the structure of the model, how it is made—by which I mean something more fundamental than anatomy alone. In quick studies you will consider the function of action, life, or expression—I call it gesture.

Some students become self-conscious and confused as soon as they attempt to draw a face. Don't think of the head or the face as something different from any other part of the body. Draw it as you would draw a hand or an elbow or a knee.

Don't try to "get a likeness" of your model. The tendency of the beginner is to separate likenesses from drawing. Draw strangers if you can because you care less what they look like. Do not draw members of your family—or at least do not show them your drawings—because their one reaction will be to look for the likeness. Keep it clearly in mind that YOU ARE NOT MAKING A PORTRAIT. You are making a study of a head.



**CHANGING THE POINT OF VIEW.** It is well known that the printed or spoken word has a tendency to take on authority once it is printed or spoken. To get away from it almost takes a revolution. The same thing is true with your own drawing. The very mistakes you make, as they linger on the paper, have this tendency to become authoritative. To combat it, move about the room during the long pose, making occasional scribbled drawings. A thing is factually the same from whatever point of view you see it, but seeing it from different points of view will illuminate the meaning of the forms and lines you have been looking at.

Whenever you are uncertain as to how to begin a study think of the movement.

## Mapping

A map is the meeting ground of drawing, writing, and geometry. No other medium carries such a wealth of critical information at glance readiness. Students of brain and thought design are lately placing more and more emphasis on the matter of Where-Is-It—apparently much of the mind's store, retrieve, and relate systems are based on position relationships in mental space.

This book is a well-made introduction to map use, map construction, and something of the meaning of maps.

We can scan the history of civilization as well as of mapping itself simply by observing which direction has topped the map. Erwin Raisz, the Harvard authority on cartography, says, "It seems to be a tendency among map makers of every country to put at the top of the map the direction toward which national attention is turned."

The Romans headed their maps as they so often did their empire-stretching ships, eastward. So did the Crusaders trying to recover the Holy Land. Many medieval wind roses have a cross as an east-mark.

Maps and charts—you may have noticed in this chapter the repetition of these two words. What's the difference in their meaning? Charts are maps with a special, practical purpose such as navigating, weather forecasting, and population studies. A chart is a map on which to work with protractor, compass, dividers, and gauges—even a densitometer.

This connection between local pinpoints and cosmic points is one of the majestic relationships recognized by science. Considering how much the mere idea of a map encompasses, maps are probably more unconfusing than anything else put down on paper. A map should be regarded as an antidote to panic.



Land-form map. Accurate information shown with vividness and grace. Drawn by Erwin Raisz for a geography textbook.

Pen pressed against T-square too hard

Pen sloped away from T-square

Pen too close to edge. Ink ran under

Ink on outside of blade, ran under

Pen blades not kept parallel to T-square

T-square (or triangle) slipped into wet line

Not enough ink to finish line

Avoidable troubles of the ruling pen

**Mapping**  
David Greenhood  
1944, 1964; 288 pp.

**\$2.95** postpaid

from:  
University of Chicago Press  
11030 South Langley Ave  
Chicago, Illinois 60628

OR WHOLE EARTH CATALOG



**The Photograph: A Social History**

Thanks to photography we are all permanently naked, especially when we try to hide behind the camera. This first book to investigate the use of photography since its invention (and ignore the "art") is crammed with more truth than I can handle at one sitting. It's the big mirror, exalted and humiliating and WEIRD. What were those people doing? (What are we?)

**The Photograph: A social History**

Michel F. Braive  
1966; 367 pp.

**\$16.95** postpaid

from:  
McGraw-Hill Book Co.  
Princeton Road  
Hightstown, N. J. 08520

8171 Redwood Highway  
Novato, CA 94947

Manchester Road  
Manchester, Mo. 63062

or **WHOLE EARTH CATALOG**

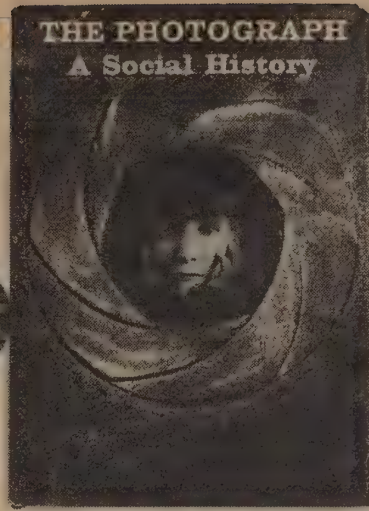

Photography makes people and things die for so brief a moment that they return from the Beyond with no idea of what has happened to them.

PIERRE MAC ORLAN  
'Masques sur mesure'



Anonymous/ 'Carte de visite'/ Spain, c. 1875



Froissard  
Flood at Lyons  
France 1856

Duchenne/ Electro-physiological analysis  
of the expression of the passions  
Paris 1876

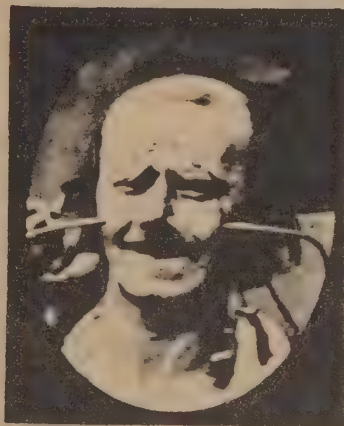
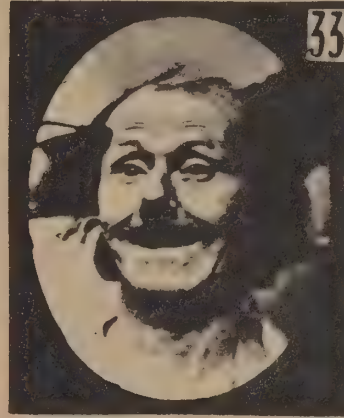

detail Photomontage/ Japan, c. 1885

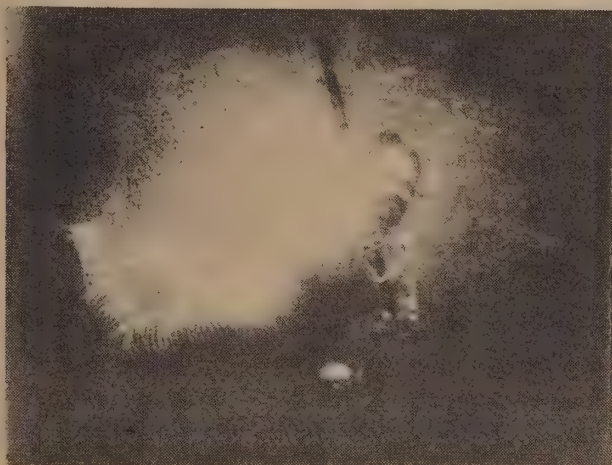

Louis Boutan  
Underwater  
photograph  
1892

**Diagrams**

A diagram is a conceptual map. Elegantly done it can ease comprehension. Thoroughly done it can aid analysis. Done with originality it can remake your internal world. This book, the first of its kind, is a splendid survey of the range and usefulness of diagramming.

Diagram from an advertisement showing proximities (considered 'near' together and confused, or 'far' apart and seldom confused) of ten vowel sounds. Air-brushed spheres in space.

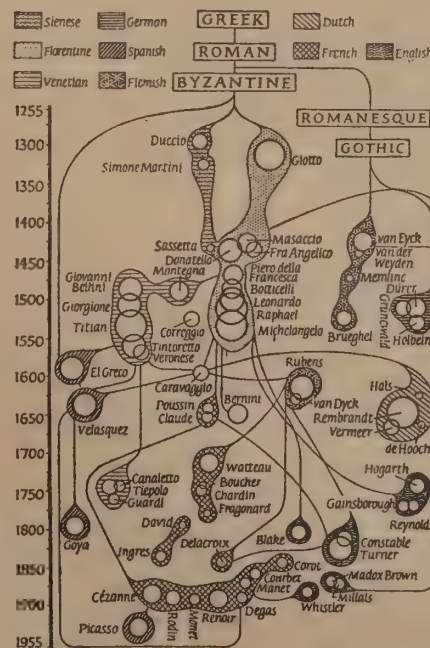
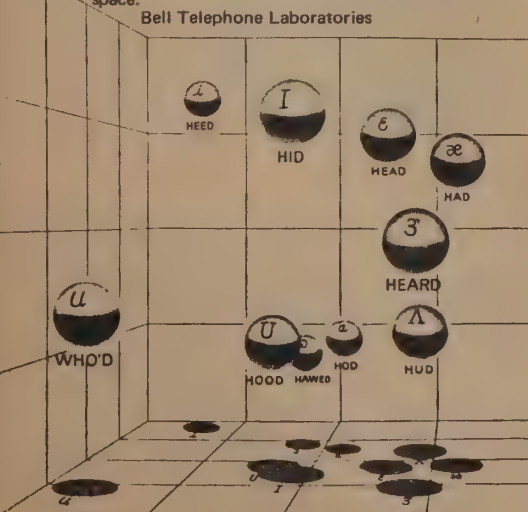
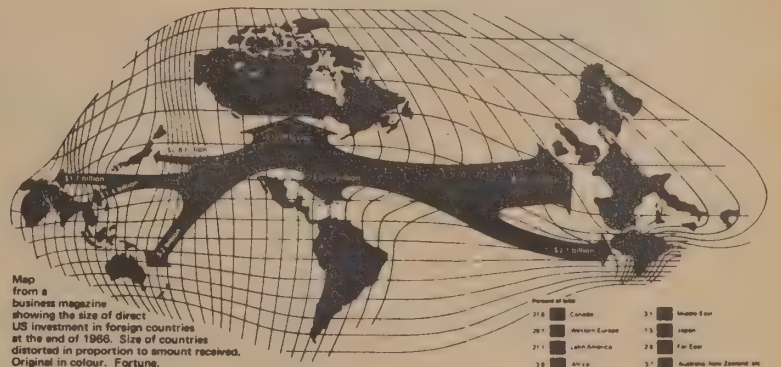
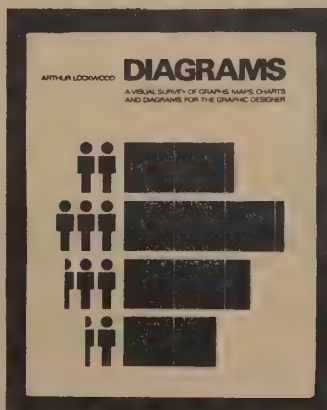

Chart from a book, showing chief schools of European painting from Giotto. Devised by Eric Newton who explains that it attempts to indicate relative importance of schools (areas of shaded masses), approximate dates, principal artists (circle), relative importance (size of circle), threads of influence between schools and artists. Eric Newton, *European Painting and Sculpture*, Faber and Faber



Map from a business magazine showing the size of direct US investment in foreign countries at the end of 1966. Size of countries distorted in proportion to amount received. Original in colour. Eortuna.



There is no attempt to give this book a historical perspective, although some of the pioneers in the effective presentation of information in visual form are included. The pioneers include magazines such as *Fortune* and *Scientific American*; firms such as the Container Corporation of America, and particularly the Isotype Institute, London, whose approach and achievement has affected all designers of diagrams even though they may not be aware of their debt.

**Diagrams**  
Arthur Lockwood  
1969; 144 pp.  
**\$15.00** postpaid

from:  
Watson-Guptill Publications  
165 West 46th Street  
New York, N. Y. 10036

or **WHOLE EARTH CATALOG**

## Intelligent Life in the Universe

Methodically blow your mind. The information in this book, mutually massaged by the American and Soviet co-authors, proceeds from superb introductions to evolutionary astronomy and biology, through a complete presentation of recent discoveries of astronomy and space science, to brilliant speculation on the parameters of inter-civilization communication. It's the best general astronomy book of recent years but that's nothing next to its impact on all the biggest questions we know.

Almost any other of the many accounts of alleged contacts of human beings with the crews of flying saucers—accounts which regale the flying saucer societies—follow the same pattern and stress the same points. The extraterrestrials are human, with few even minor physical differences from local cosmetic standards. (I know of no case of Negro saucerians, or Oriental saucerians, reported in the United States; but there are very few flying saucer reports made in this country by Negroes or by Orientals.)

So, by an interesting coincidence, the distances between the stars in interstellar space, relative to their diameters, are just about the same as the distances between the atoms and molecules in interstellar space, relative to their diameters. Interstellar space is as empty as a cubical building, 60 miles long, 60 miles wide, and 60 miles high, containing a single grain of sand.

Taken at face value, the legend suggests that contact occurred between human beings and a non-human civilization of immense powers on the shores of the Persian Gulf, perhaps near the site of the ancient Sumerian city of Eridu, and in the fourth millennium B.C. or earlier. There are three different but cross-referenced accounts of the *Apkallu* dating from classical times.

But how can a natural satellite have such a low density? The material of which it is made must have a certain amount of rigidity, so that cohesive forces will be stronger than the gravitational tidal forces of Mars, which will tend to disrupt the satellite. Such rigidity would ordinarily exclude densities below about  $0.1 \text{ gm cm}^{-3}$ . Thus, only one possibility remains. Could Phobos be indeed rigid, on the outside—but hollow in the inside? A natural satellite cannot be a hollow object. Therefore, we are led to the possibility that Phobos—and possibly Deimos as well—may be artificial satellites of Mars.

Radio astronomers may be interested to know that the so-called "brightness temperature" of the Earth at television wavelengths is some hundreds of millions of degrees. This is 100 times greater than the radio brightness of the sun at comparable wavelengths, during a period of low sunspot activity.

With  $10^{11}$  stars in our Galaxy and  $10^9$  other galaxies, there are at least  $10^{20}$  stars in the universe. Most of them, as we shall see in subsequent chapters, may be accompanied by solar systems. If there are  $10^{20}$  solar systems in the universe, and the universe is  $10^{10}$  years old—and if, further, solar systems have formed roughly uniformly in time—then one solar system is formed every  $10^{-10} \text{ yr} = 3 \times 10^{-3}$  seconds. On the average, a million solar systems are formed in the universe each hour.

The existence of more than one universe is impossible, by definition.

"Well, ladies and gentlemen," Struve concluded, "it was pretty dull on Epsilon Eridani and Tau Ceti eleven years ago."



**Intelligent Life in the Universe**  
I. S. Shklovskii and Carl Sagan  
1966; 509 pp.

**\$2.95** postpaid

from:  
Delta Books  
c/o Montville Warehousing Co., Inc.  
Changebridge Rd.  
Pine Brook, N.J. 07058

900 Pratt Blvd.  
Elk Grove Village, Illinois 60007  
1104 S. Lawrence Street  
Los Angeles, Calif. 90021

or WHOLE EARTH CATALOG

11110000101001000011001000000010000010100  
1000011001011001111000001100001101000000  
00100000100001000010001010100001000000000  
0000000001000100000000001011000000000000  
0000001000111011010110101000000000000000  
000010010000111010101010100000000101010101  
0000000011101010101110101100000001000000  
0000000001000000000000001000100111111000  
00111010000010110000011100000010000000000  
1000000010000000111110000001011000101110  
100000001100101111010111100010011111001  
000000000011111000000101100011111100000  
1000011000001100001000011000000011000101  
001000111100101111

1. decode this →
2. into this →

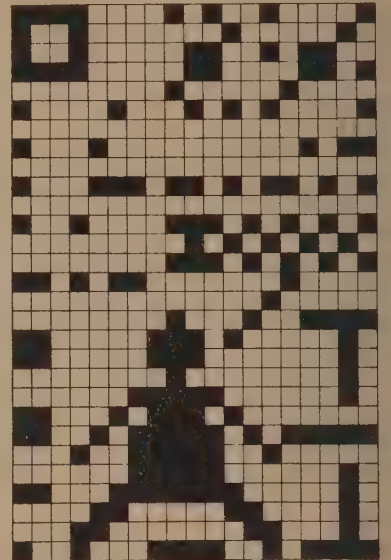

3. now decode this for physiological, astronomical, chemical, mathematical, social, historical, and linguistic information

## Cybernetic Serendipity

This book started life as an exhibit at the Institute of Contemporary Arts in London last year. Simultaneously it was an issue of Studio International magazine. It must have been an Event. Certainly it is the best collection of computer art yet, the only one not dismissable as engineers kidding themselves. There's been talk for years (e.g. The New Landscape, 1956) of how art and science are gonna come together, and indeed communications have improved. But there was no direct avenue, no real mutual domain. Not until computers got common enough for funky hands to lay hold of them to do tricks for funky heads. That's happening now, and this book is good evidence. Ahead, deep space.

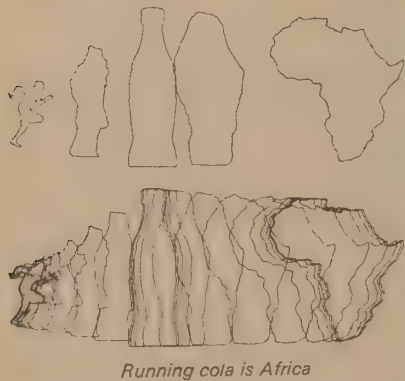

To co-operate or even to orient themselves and to engage their programmes, the mobiles must communicate. They do so in a simple but many-levelled language of light flashes and sounds. You may engage in this discourse if you wish to, though your goals may be alien to the goals of the mobiles; for example, you might be trying to achieve a configuration that you regard as pleasing.

**Cybernetic Serendipity**  
1969; 100 pp.; 260 illustrations  
**\$8.95** postpaid

from:  
Frederick A. Praeger, Publisher  
111 Fourth Avenue  
New York, N. Y. 10003

or WHOLE EARTH CATALOG

In our discussion up to this point, we have considered only interstellar radio contact among civilizations at or just slightly beyond our present state of technical advance. Yet the bulk of technical civilizations in the universe may be immensely more advanced than ours—perhaps even billions of years beyond. The Soviet astrophysicist N.S. Kardashev, an associate of I.S. Shklovskii at the Sternberg Astronomical Institute, has considered the possibility of the detection of signals from such greatly advanced civilizations. He classifies possible technologically advanced civilizations in three categories: (I) A level of technological advance close to that of the contemporary terrestrial civilization. The rate of energy consumption is about  $4 \times 10^{19}$  ergs  $\text{sec}^{-1}$ . (II) A civilization capable of utilizing and channeling the entire radiation output of its star. The energy utilization would then be comparable to the luminosity of our Sun, about  $4 \times 10^{33}$  ergs per second. In Chapter 34, we will consider a specific proposal for the harnessing of such power. (III) A civilization with access to the power comparable to the luminosity of an entire galaxy, some  $4 \times 10^{44}$  ergs per second.

The information contained in a single human sperm cell is equivalent to that of 133 volumes, each of the size and fineness of print of Webster's Unabridged Dictionary.

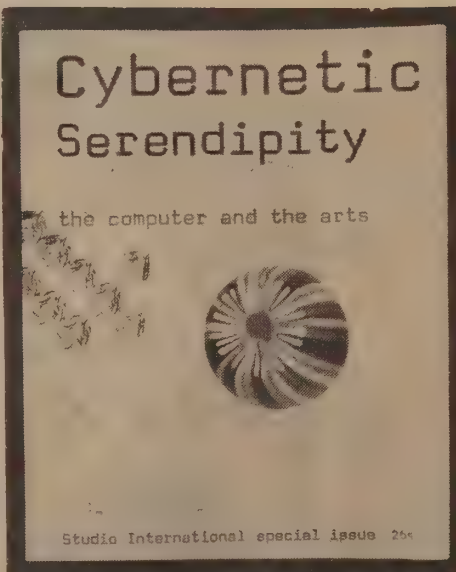

- 1 Poem  
eons deep in the ice  
I paint all time in a whorl  
bang the sludge has cracked
- 2 Poem  
eons deep in the ice  
I see gelled time in a whorl  
pffttt the sludge has cracked
- 3 Poem  
all green in the leaves  
I smell dark pools in the trees  
crash the moon has fled
- 3 Poem  
all white in the buds  
I flash snow peaks in the spring  
bang the sun has fogged



(Art, if you want a definition of it, is criminal action. It conforms to no rules. Not even its own. Anyone who experiences a work of art is as guilty as the artist. It is not a question of sharing the guilt. Each one of us gets all of it.)

A sustained image of the visual world around us is maintained by the brain's continual coordination of a great flux of varying sensory input. Much of this co-ordination is achieved by the series of voluntary and involuntary eye-movements which serve to scan the image of the pattern across the retina. When these eye-movements are eliminated, or controlled, a remarkable collapse of the perceptual process occurs in which visual patterns disintegrate—but in non-random fashion, and according to "rules" which appear to be common to all humans. The device, which we have called the CYBERNETIC INTROSPECTIVE PATTERN—CLASSIFIER—because that is as good a description as any—is not

really the exhibit itself: it is by means of this device that the human brain can be turned into its own exhibit. People looking into the CIPC will be given a brief, bright flash of a pattern which plants an image on the retina in such a way that it can be seen, with eyes closed, for one or two minutes. Since the image is fixed on the retina, eye movements are irrelevant, and the perceptual system collapses as described above. The pattern can be seen to fragment and change its form, and these forms are probably the basic perceptual units used by the brain in recognising the pattern. This exhibit therefore allows people to watch their own cerebral processes actually in action.

## Understanding Media

Everybody talks about McLuhan, and everybody does something about him, and that makes it subjectively harder to get at him. He's got other insights than what you hear about, so it's worth the trouble to track him down, both his current sayings and his prime collections. An excellent set of recent sayings was in a *Playboy* interview a few months ago (he foresaw the imminent demise of language into global telepathy: 'The body of Christ'). For prime collection the primest is *Understanding Media*.

[Suggested by Gerd Stern, then.]

### Understanding Media

Marshall McLuhan  
1964; 318 pp.

\$ .95 postpaid

from:  
Signet—New American Library, Inc.  
1301 Avenue of the Americas  
New York, N. Y. 10019

or WHOLE EARTH CATALOG

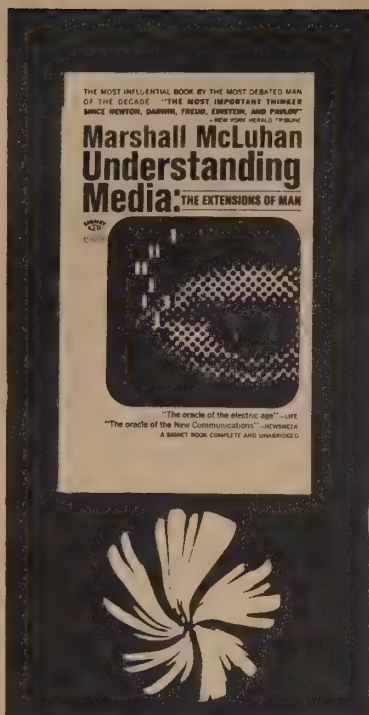

Eventually the method of the counting board gave rise to the great discovery of the principle of position in the early centuries of our era. By simply putting 3 and 4 and 2 in position on the board, one after another, it was possible to step up the speed and potential of calculation fantastically. The discovery of calculation by positional numbers rather than by merely additive numbers led, also, to the discovery of zero. Mere positions for 3 and 2 on the board created ambiguities about whether the number was 32 or 302. The need was to have a sign for the gaps between numbers. It was not till the thirteenth century that *sifr*, the Arab word for 'gap' or 'empty,' was Latinized and added to our culture as 'cipher' (ziphirum) and finally became the Italian zero. Zero really meant a positional gap.

'Work,' however, does not exist in a nonliterate world. The primitive hunter or fisherman did no work, any more than does the poet, painter, or thinker of today. Where the whole man is involved there is no work.

If the phonetic alphabet was a technical means of severing the spoken word from its aspects of sound and gesture, the photograph and its development in the movie restored gesture to the human technology of recording experience.

Man the food-gatherer reappears incongruously as information-gatherer. In this role, electronic man is no less a nomad than his paleolithic ancestors.

Everybody experiences far more than he understands. Yet it is experience, rather than understanding, that influences behavior, especially in collective matters of media and technology, where the individual is almost inevitably unaware of their effect upon him.

It is a principal aspect of the electric age that it establishes a global network that has much of the character of our central nervous system. Our central nervous system is not merely an electric network, but it constitutes a single unified field of experience. As biologists point out, the brain is the interacting place where all kinds of impressions and experiences can be exchanged and translated, enabling us to react to the world as a whole.

Said the Duke of Gloucester to Edward Gibbon upon the publication of his *Decline and Fall*: 'Another damned fat book, eh, Mr. Gibbon? Scribble, scribble, scribble, eh, Mr. Gibbon?'

As W. B. Yeats wrote of this reversal, 'The visible world is no longer a reality and the unseen world is no longer a dream.'

Language does for intelligence what the wheel does for the feet and the body. It enables them to move from thing to thing with greater ease and speed and ever less involvement.

Even slight changes in the environment of the very well adjusted find them without any resource to meet new challenge. Such is the plight of the representatives of 'conventional wisdom' in any society. Their entire stake of security and status is in a single form of acquired knowledge, so that innovation is for them not novelty but annihilation.

Meantime, the countryside, as oriented and fashioned by plane, by highway, and by electric information-gathering, tends to become once more the nomadic trackless area that preceded the wheel.

Not only does the visual, specialist, and fragmented Westerner have now to live in closest daily association with all the ancient oral cultures of the earth, but his own electric technology now begins to translate the visual or eye man back into the tribal and oral pattern with its seamless web of kinship and interdependence.

## Cybernetics

McLuhan's assertion that computers constitute an extension of the human nervous system is an accurate historical statement. The research and speculation that led to computer design arose from investigation of healthy and pathological human response patterns embodied in the topological make-up of the nervous system. Insights here soon expanded into generalizations about communication that permitted the building of analogous electronic devices physically separate from the Central Nervous System. But they're just one artifact of these new understandings about communication. Society, from organism to community to civilization to universe, is the domain of cybernetics. Norbert Wiener has the story, and to some extent, is the story.

To predict the future of a curve is to carry out a certain operation on its past.

The central nervous system no longer appears as a self-contained organ, receiving inputs from the senses and discharging into the muscles. On the contrary, some of its most characteristic activities are explicable only as circular processes, emerging from the nervous system into the muscles, and re-entering the nervous system through the sense organs, whether they be proprioceptors or organs of the special senses. This seemed to us to mark a new step in the study of that part of neurophysiology which concerns not solely the elementary processes of nerves and synapses but the performance of the nervous system as an integrated whole.

The feedback of voluntary activity is of this nature. We do not will the motions of certain muscles, and indeed we generally do not know which muscles are to be moved to accomplish a given task; we will, say, to pick up a cigarette. Our motion is regulated by some measure of the amount by which it has not yet been accomplished.

I have spoken of the race. This is really too broad a term for the scope of most communal information. Properly speaking, the community extends only so far as there extends an effectual transmission of information. It is possible to give a sort of measure to this by comparing the number of decisions entering a group from outside with the number of decisions made in the group. We can thus measure the autonomy of the group. A measure of the effective size of a group is given by the size which it must have to have achieved a certain stated degree of autonomy.

Thus small, closely knit communities have a very considerable measure of homeostasis; and this, whether they are highly literate communities in a civilized country or villages of primitive savages. Strange and even repugnant as the customs of many barbarians may seem to us, they generally have a very definite homeostatic value, which it is part of the function of anthropologists to interpret. It is only in the large community, where the Lords of Things as They Are protect themselves from hunger by wealth, from public opinion by privacy and anonymity from private criticism by the laws of libel and the possession of the means of communication, that ruthlessness can reach its most sublime levels. Of all of these anti-homeostatic factors in society, the control of the means of communication is the most effective and most important.

The mongoose begins with a feint, which provokes the snake to strike. The mongoose dodges and makes another such feint, so that we have a rhythmic pattern of activity on the part of the two animals. However, this dance is not static but develops progressively. As it goes on, the feints of the mongoose come earlier and earlier in phase with respect to the darts of the cobra, until finally the mongoose attacks when the cobra is extended and not in a position to move rapidly. This time the mongoose's attack is not a feint but a deadly accurate bite through the cobra's brain.

In other words, the snake's pattern of action is confined to single darts, each one for itself, while the pattern of the mongoose's action involves an appreciable, if not very long, segment of the whole part of the fight. To this extent the mongoose acts like a learning machine, and the real deadliness of its attack is dependent on a much more highly organized nervous system.

To use a biological analogy, the parallel system had a better homeostasis than the series system and therefore survived, while the series system eliminated itself by natural selection.

We thus see that a non-linear interaction causing the attraction of frequency can generate a self-organizing system. . . .



### Cybernetics — or Control and Communication in the Animal and the Machine

Norbert Wiener  
1948, 1961; 212 pp.

\$2.45 postpaid

from:  
The M. I. T. Press  
Cambridge, Mass. 02142

or WHOLE EARTH CATALOG

**\* Technicians of the Sacred**

*These are songs from the center, from the middle. (The cortex of humanity is convoluted, each fold patriotic, distinct on the outside, connected in the middle.) Superb editing by Rothenberg. A book to take with you.*

Technicians of the Sacred ed. Jerome Rothenberg 1968; 521 pp. \$3.95 postpaid from: Doubleday & Co. 501 Franklin Garden City, N. Y. 11531 or WHOLE EARTH CATALOG

**PRIMITIVE MEANS COMPLEX**

That there are no primitive languages is an axiom of contemporary linguistics where it turns its attention to the remote languages of the world. There are no half-formed languages, no underdeveloped or inferior languages. Everywhere a development has taken place into structures of great complexity. People who have failed to achieve the wheel will not have failed to invent & develop a highly wrought grammar. Hunters & gatherers innocent of all agriculture will have vocabularies that distinguish the things of their world down to the finest details. The language of snow among the Eskimos is awesome. The aspect system of Hopi verbs can, by a flick of the tongue, make the most subtle kinds of distinction between different types of motion.



What are you saying to me & am I in-my-senses?

(Ojibwa)

**An Eskimo Poem against Death**

I watched the white dogs of the dawn.



**ALL LIVES, ALL DANCES, & ALL IS LOUD**

The fish does . . . HIP  
The bird does . . . VISS  
The marmot does . . . GNAN

I throw myself to the left,  
I turn myself to the right,  
I act the fish,  
Which darts in the water, which darts  
Which twists about, which leaps—  
All lives, all dances, & all is loud.

The fish does . . . HIP  
The bird does . . . VISS  
The marmot does . . . GNAN

(Gabon Pygmy)

the odor of death  
I discern the odor of death  
in front of my body

—Namebines  
(Ojibwa)

the blue, overhanging  
sky  
answers me back

—Wabezic  
(Ojibwa)

There is no one; there are no people. It is desolate; it lies desolate. There is nothing edible. Misery abounds, misery emerges, misery spreads. There is no joy, no pleasure. It lies sprouting; herbs lie sprouting; nothing lies emerging; the earth is pressed down. All die of thirst. The grasses lie sprouting. Nothing lies cast about. There is hunger; all hunger. It is the home of hunger; there is death from hunger. All die of cold; there is freezing; there is trembling; there is the clattering, the chattering of teeth. There are cramps, the stiffening of the body, the constant stiffening, the stretching out prone.

(Aztec)



I am using my heart

(Ojibwa)

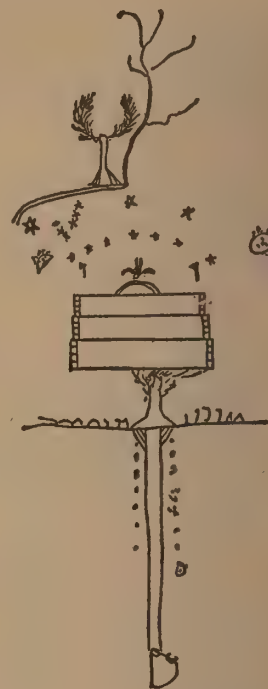

—Red Corn  
(Osage)

I am still carving an ironwood stick.  
I am still thinking about it.

(Bantu)

To say: Doer, doer; passer, passer;  
thy face behind thee; guard thyself against the great door.

(Utterance 280, Egypt)

**GENESIS I**

Water went they say. Land was not they say. Water only then, mountains were not, they say. Stones were not they say. Fish were not they say. Deer were not they say. Grizzlies were not they say. Panthers were not they say. Wolves were not they say. People were washed away they say. Grizzlies were washed away they say. Panthers were washed away they say. Deer were washed away they say. Coyotes were not then they say. Ravens were not they say. Herons were not they say. Woodpeckers were not they say. Then wrens were not they say. Then hummingbirds were not they say. Then otters were not they say. Then jack-rabbits, grey squirrels were not they say. Then long-eared mice were not they say. Then wind was not they say. Then snow was not they say. Then rain was not they say. Then it didn't thunder they say. Then trees were not when it didn't thunder they say. It didn't lighten they say. Then clouds were not they say. Fog was not they say. It didn't appear they say. Stars were not they say. It was very dark.

(Kato Indian)

**GARBAGE EVENT**

1. Pigs and chickens feed on the grass in an inhabited area until it is bare of grass.
2. Garbage is added to the area.
3. The participants defend the "abandoned beauty" and "town-quality" of the environment against all critics.

**Sample defense:**

**Critic.** This place is dirty.  
**Answer.** It is filthy.

**Critic.** Why don't you clean it up?  
**Answer.** We like it the way it is.

**Critic.** Garbage is unhealthy.  
**Answer.** The pigs feed better in it.

**Critic.** It breeds mosquitoes.  
**Answer.** There are more mosquitoes in a jungle.

(Borneo: Dayak)

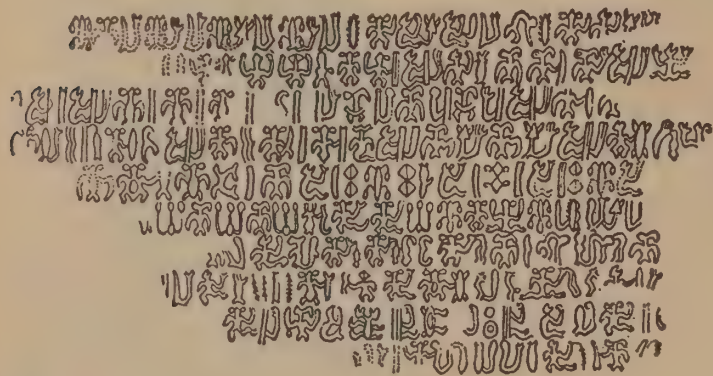

We are talking to each other

(Easter Island)

(Ojibwa)



**By the Late John Brockman**

*John Brockman, though dead, is in his late twenties and agile in New York. His book is an interpretation of recent work in brain-study, information theory, and art. It proposes that man is dead, replaced by a superior being—once he learns this—called invisible.*

Man is dead.  
[Good riddance.]

Man is dead. Credit his death to an invention. The invention was the grasping of a conceptual whole, a set of relationships which had not been previously recognized. The invention was man-made. It was the recognition that reality was communicable. The process was the transmission of neural pattern. Such patterns are electrical, not mental. The system of communication and control functioned without individual human awareness or consent. The message in the system was not words, ideas, images, etc. The message was nonlinear: operant neural pattern. It became clear that "new concepts of communication and control involved a new interpretation of man, of man's knowledge of the universe, and of society."\*  
Man is dead. "We're talking."

Every movie is the first movie. The brain goes into its stereotyped movie program even before the ticket is purchased. The information received by the brain from the experience of purchasing a ticket may be enough to activate the hormonal responses of the movie experience. Buy your ticket: See the movie.



It is not necessary to say Yes to life.  
No one is there to listen; no one is interested in your words.

**By the Late John Brockman**

John Brockman;  
1969; 166 pp.

\$6.95 postpaid

from: Macmillan Company  
Front and Brown Streets  
Riverside, Burlington County  
New Jersey 08075

or WHOLE EARTH CATALOG

The concept of ecumenical technology provides a frame of reference which points to clues about the invisible stage of evolution. The ecumenicism of technology is the unitive force that can make all brains perform the same operations simultaneously. Ecumenical technology is the key to the simultaneous universe of electronic communications. Consider that in the pre-electric age the operations of multitudes of brains in the world would function on different frequency bands. With electronics, an important event on television will mean that on the neural level millions upon millions will have a ray projected onto their retina, providing their brains with the information needed to maintain continuity. This information measures a change in the brain's activity, a frequency modulation. Every brain working the same way, on the same frequency, the same wavelength, performing the same operations simultaneously. Not brotherhood, but unity. Ecumenical technology.

It was all invisible to man. The clash of generations, the crashing down of institutions, the divisiveness—it was all invisible. Man never knew what was happening. To the invisible, it was a question of nonsynchronization of frequencies, where certain brains were unable to adapt to new rhythms of the information received within parameters consistent with continuity. It became a question of phylogenic suicide. To the invisible: out of phase. To man: out of mind. Who's crazy?

**Number Words and Number Symbols**

There's lots of ways to invent things—two big ones that this CATALOG promotes both involve the return to rudiments, but in different ways. Invention-By-Usefulness is People's invention—a flock of people go live a different way: the new methods that arise to aid their different living are their inventions (subject to no prices, patents, marketability, or even notice usually). Invention-by-Inventor, on the other hand, involves a double perception by an individual—he perceives a potential usefulness for something, and he perceives the roots of a set of tools that may be adapted or combined to perform the new usefulness.

"Academic" study, of little use to the flock of pioneers, is essential to the inventor, especially the study of the origins of crafts he's working in. Take numbers. Suppose you want to help human communication to re-understand itself. So much of that understanding is wrapped up in numbers that if you penetrate the one you may have a foothold to tweak the other onto a new course. Invent language and you invent man.

This book penetrates numbers.

**Number Words and Number Symbols**

Karl Menninger  
1958, 1969; 480 pp.

\$15.00 postpaid

from:  
The M. I. T. Press  
Cambridge, Mass 02142

or WHOLE EARTH CATALOG



Fig. 222 Chinese fork coin, with the number 34 written in abstract place-value notation. Ca. A.D. 20.



In the seaports and market places of the Red Sea, Arabia, and East Africa, merchants have evolved a finger language that is understood in every market of every country in the region. Buyers and sellers come to terms underneath a cloth, a fold of garment or a strip of muslin from a turban, by touching the fingers of each other's hand and thus bargaining in complete privacy.

When Buddha reached the age of manhood he courted Gopa, the daughter of the Prince Dandapani. But he would be rejected unless he could show public proof of his abilities. And so, together with five other suitors, he was put through trials in writing, wrestling, archery, running, swimming, and number skills. In all these contests he brilliantly defeated his rivals. After the competition, Gopa's father commanded him to pit himself against the great mathematician Arjuna, who was to be the measure of Buddha's knowledge. Arjuna instructed him to list all the numbers (that is, the numerical ranks) above 100 kotis. Koti was the name of the seventh rank, meaning 10<sup>7</sup> or 10 millions. Beyond sahasra (10<sup>3</sup>), Indians at an early date had ayuta (10<sup>4</sup>), niuta, also called lakṣa (10<sup>5</sup>), and prayuta (10<sup>6</sup> = a million).

Buddha answered:

- |  |                    |
|--|--------------------|
| koti (10 <sup>7</sup> , abbreviated 7) | hetuhila (31)      |
| ayuta = 100 kotis (9)                  | karahu (33)        |
| niyuta (11)                            | Hetvindriya (35)   |
| kangkara (13)                          | samaptalamba (37)  |
| vivara (15)                            | ganaganati (39)    |
| aksobhya (17)                          | niravadya (41)     |
| vivaha (19)                            | mudrabala (43)     |
| utsanga (21)                           | sarvabala (45)     |
| bahula (23)                            | visandjnagati (47) |
| nagabala (25)                          | sarvasandjna (49)  |
| titilamba (27)                         | vibhutangama (51)  |
| vyavasthanapradjnapti (29)             | tallakṣana (53).   |

Fig. 242 Albrecht Dürer's year dates. In writing the dates of the years around 1495, Dürer illustrated the development of the 4 into its present form. From three of his drawings dated in successive years.

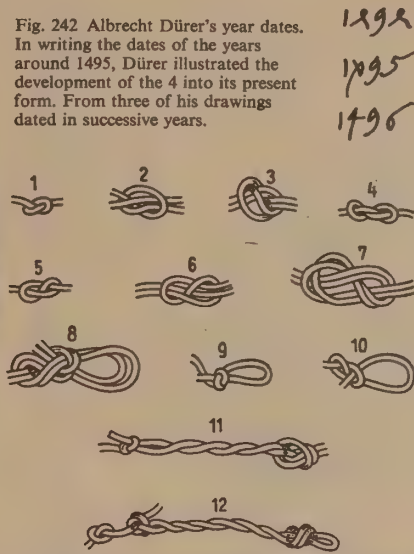

Fig. 90 Miller's knots used to indicate amounts and kinds of flour.

1 2 3 4 5 6 7 8 9 and 0 — these ten symbols which today all peoples use to record numbers, symbolize the world-wide victory of an idea. There are few things on earth that are universal, and the universal customs which man has successfully established are fewer still. But this is one boast he can make: The new Indian numerals are indeed universal.

**A Study of Writing**

Not as good as it should be, this is still the best introduction around to the growth and diffusion of language notation systems.

**A Study of Writing**

I. J. Gelb  
1952; 319 pp.

\$2.95 postpaid

from:  
University of Chicago Press  
11030 South Langley Avenue  
Chicago, Illinois 60628

or WHOLE EARTH CATALOG



Colour does not seem to play an important role in our modern writing. Although colouring schemes are occasionally used to differentiate meaning, as in charts, it is normally the black or dark colour that predominates, whether in our handwriting or book print. In older times, when all writing was done by hand, colour differentiation was found more frequently. Both the old Mexican writings and the more modern writings of the American Indians frequently employ a method of colouring the signs. Among the Cherokee Indians white colour is used for peace or happiness, black for death, red for success or triumph, blue for defeat or trouble.

HIEROGLYPHIC	HIEROGLYPHIC BOOK SCRIPT	HIERATIC	DEMOTIC

The retrograde evolution of individual writings was frequently facilitated whenever they fell under the control of a priestly or political caste. In such cases the systems gradually became so overburdened with various artificial and baroque deflections that they grew too difficult for large masses of people to master. The final result of such degenerated writing was frequently its total rejection by the people and its replacement by an entirely new system introduced from abroad.

**aUI: The Language of Space**

(ah-oo-ee)

Good deal. Here's a guy who's invented a language, and it's kind of neat. It sounds like Hawaiian. The writing is a blend of picture-writing and sound-representation. Words are made entirely by combination among the 32 basic concepts/sounds/symbols. Dr. Weilgart thinks it could save the world.

[Suggested by J. Baldwin]

**aUI: The Language of Space**

Dr. John W. Weilgart  
1962; 250 pp.

\$4.00 postpaid from:

Cosmic Communication Company  
100 Elm Court  
Decorah, Iowa 52101

or  
S. Chand & Co.  
Ram Nagar  
New Delhi-55  
INDIA

**The Language of Space**

Categories of aUI:	Symbol, Sound	Meaning	Pronunciation:

**Short-Cut Shorthand**

Writing is slower than talking, and thereby hangs a lot of problems. If you need to write fast you have approximately three choices of method: Gregg (the fastest, but really hard to learn), Speedwriting (slowest, a cinch to learn), and this (medium fast, medium easy to learn). The book is well designed for self-teaching.

**Short-Cut Shorthand**

S. M. Wesley  
1966; 275 pp.

\$3.95 postpaid

from:  
Cowles Education Corporation  
488 Madison Avenue  
New York, N. Y. 10022

or WHOLE EARTH CATALOG

PHONETIC SYSTEM. Unlike other shorthand systems, Short-Cut Shorthand follows a purely phonetic system. It has no hieroglyphic-like forms or subtle differences in lines that need to be learned and interpreted. The forms are distinctive and clear cut. Once you learn the character for a particular sound you continue to use it throughout. You just write down what you hear.

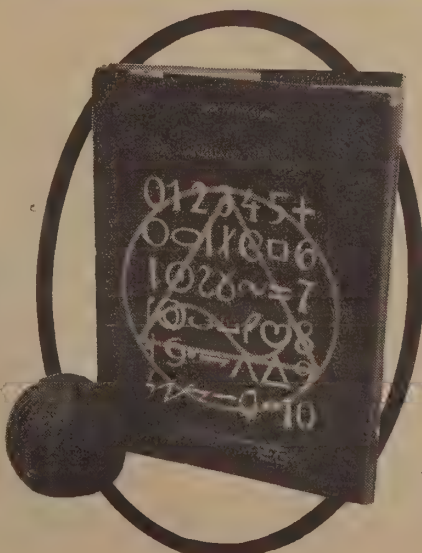
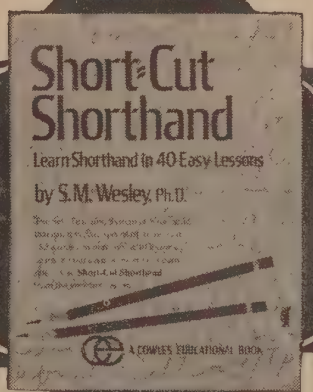

**"U" : a, A, b, f; g**

U = MIND, MENTALITY, SPIRIT, INTELLLECT, abstract thought, idea.  
-U = concept: This ending transforms a word into an abstract noun, e. g.  
nUm = wise, nUmU = wis-dom; ynUm = stupid, ynUm-U = stupid-ity, -ness.  
aturv = colonize, aturv-U = coloniz-ation; u = man, u-U = man-kind.

**U : a, A, b, f;**

--vu vUioV vaUs, yvu yUioV sE. --

vaUs = letter, epistle = make-space-mind-thing: a letter is a thing (s) which enables the mind (U) to travel through, to "make-space", to make its way through space.  
--ag vaUs, fu vav (send) fum U at fum bru. -- In a letter, I send (vEv av = make-go) my mind to my friend. Letter = "send-thoughts". ("letter" as part of a word, is UIz = word-part, see "U": I, below!)  
Uwa = office = mind-power-space, duty-space: "You must meet him in his "office"! means: "You must meet him in his place, "space", sphere, of (mental) power, in his duty sphere.

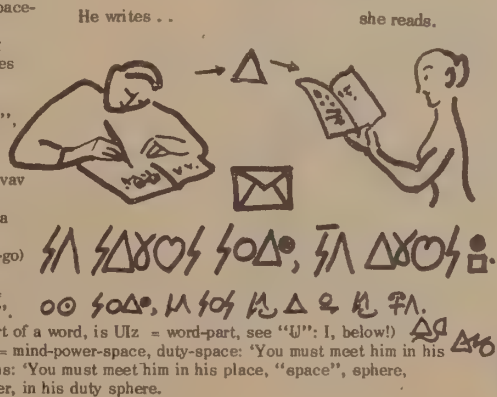



The patterns we observe on the shore of a river when the mud has been dried up by the sun (98) seem to be quite irregular; nevertheless as a rule they show right angles. This can be explained by assuming the cracking to be an effect of contraction; the line appearing as a fissure has, by a principle of mechanics, to make the work of disjunction as small as possible. The work is proportional to the areas of the sections and the lines must have a course such as to minimize the surfaces laid open by the fissure. This procedure gives right angles if the clay is homogeneous; the varying thickness of the layer accounts for the curvature of the lines. This remark supplies in many cases a means of deciding which line appeared earlier and which later: the older of the two splits passes right through the point of junction. Thus we can follow the genealogy of splits and eventually find the ancestors of the whole system.



Suppose the pattern was composed initially of two regions, A, and B. A new line appears, joining two points of two already existing arcs and giving rise to a new region C (100); since the new line breaks up two arcs into two parts each, the number of arcs increases by three. After  $n$  steps we have  $n$  more regions and  $3n$  more arcs. Since there were initially two regions and three arcs, we now have  $n+2$  regions and  $3n+3$  arcs.

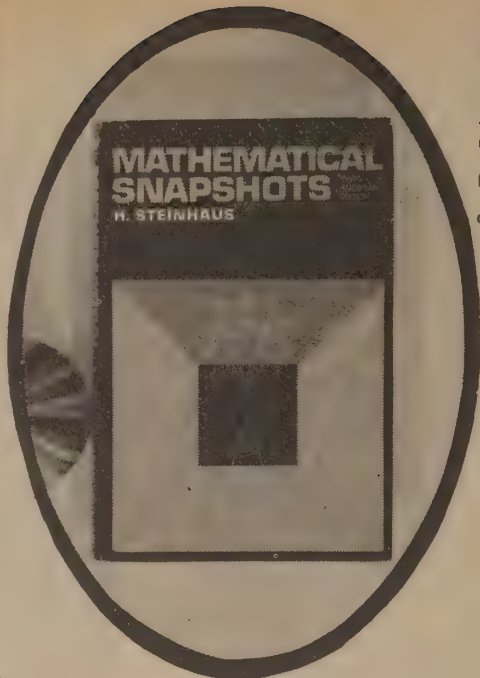

**Mathematical Snapshots**  
H. Steinhaus  
1950, 1969; 311 pp.

**\$7.50** postpaid

from:  
Oxford University Press  
16-00 Pollitt Drive  
Fair Lawn, N. J. 07140

or WHOLE EARTH CATALOG

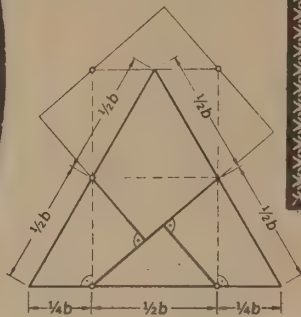

2

From these four small boards (1) we can compose a square or an equilateral triangle, according as we turn the handle up or down. The proof is given by sketch (2).

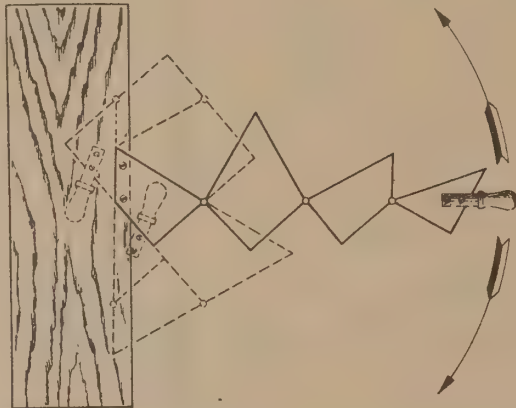

**Mathematical Models**  
H. Martyn Cundy & A. P. Rollett  
1961; 286 pp.

**\$6.50** postpaid

from:  
Oxford University Press  
16-00 Pollitt Drive  
Fair Lawn, N. J. 07140

or WHOLE EARTH CATALOG

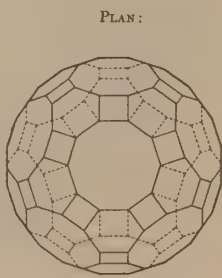

FIG. 138

$F_4$	$F_6$	$F_{10}$	$V$	$E$
30	20	12	120	180

POLYHEDRA

3.9.4. Great stellated triacontahedron.  $V(3, \frac{5}{2})^2$



FIG. 153

Obviously, for any model which is to be at all permanent, cardboard will be used.

The card should be white with a good surface, and fairly thin, about the thickness of a plain postcard. Thick cardboard makes ugly corners, and allowance ought to be made for its thickness in drawing the net. It is useful, however, to cut flat sheets of thick card for internal strengthening in some of the stellated and interpenetrating polyhedra.

3.7

POLYHEDRA

3.7.12. Great rhombicosidodecahedron (cont.)

NET:

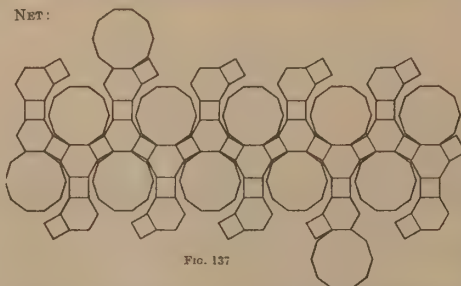

FIG. 137

When the dimensions of the model have been decided on, the net can be constructed on the cardboard. In the case of a complicated net this is facilitated by pricking through vertices from a template drawn on tracing paper, but it must be done very accurately. Tabs are then added to alternate outside edges, care being taken to ensure that the angle at the shoulder of the tab is small enough to admit of the tab's being cemented to its appropriate face. The net can now be cut out with a razor-blade and the edges scored half-through for bending. (Where edges have to be scored on the back—in the stellated polyhedra—this is indicated in the diagrams.) The face of the net becomes the outside of the polyhedron.

For joining, a quick-drying cement, such as balsa-wood cement as used for model aircraft, is essential. After the cement has been applied to a tab, the edges to be joined are brought together, and the tab can be held down with a small wire paper-fastener while the cement dries. This is particularly useful in small models when the fingers cannot easily get inside, and near the finish of any model when there are several edges to be joined at once. A thin wire probe is sometimes useful in getting the last face to adhere.

**Mathematics**

*As far as we're concerned, these are the principles as well as method in the universal language.*

**Mathematical Snapshots operates by visibility. What's going on mathematically is plain as day in the diagrams and illustrations. It's like learning history by anecdotes.**

**Mathematical Models is a classic of 4-D technique. The whole purpose of the book is enabling you to make your own geometric forms in the world. Like learning history by psychodrama.**

[Suggested by Sim Van Der Ryn]

The World of Mathematics, a collection of mathematical anecdotes, ancient, recent, and modern.

Mathematics and Meaning in Russian—comprehensive, everything of today.

Problem 36 of the papyrus begins: "Go down 1 times 3, 1/3 of me, 1/5 of me is added to me; return 1, filled am I. What is the quantity saying it?"

**World of Mathematics**  
James Newman  
1956; 2469 pp; 4 vols.

**\$12.95** postpaid

from:  
Simon & Schuster, Inc.  
630 Fifth Avenue  
New York, N. Y. 10011

or WHOLE EARTH CATALOG

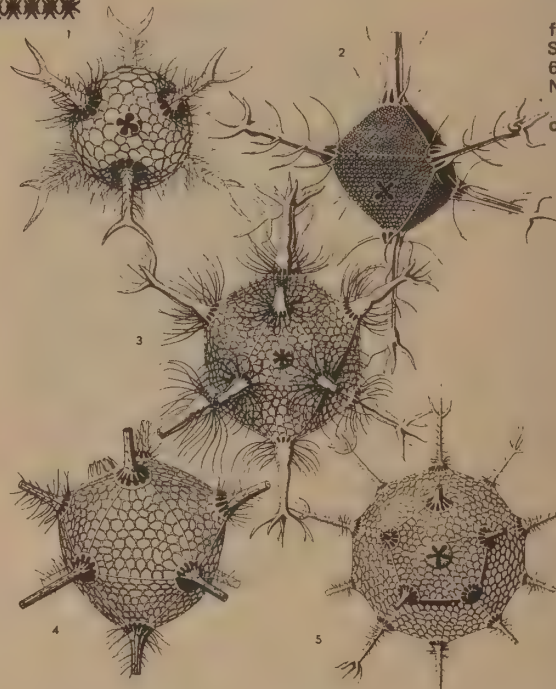

Here (Figure 45) is a page from Hæckel's Challenger Monograph showing the skeletons of several Radiolarians. Numbers 2, 3, and 5 are octahedron, icosahedron, and dodecahedron in astonishingly regular form; 4 seems to have a lower symmetry.

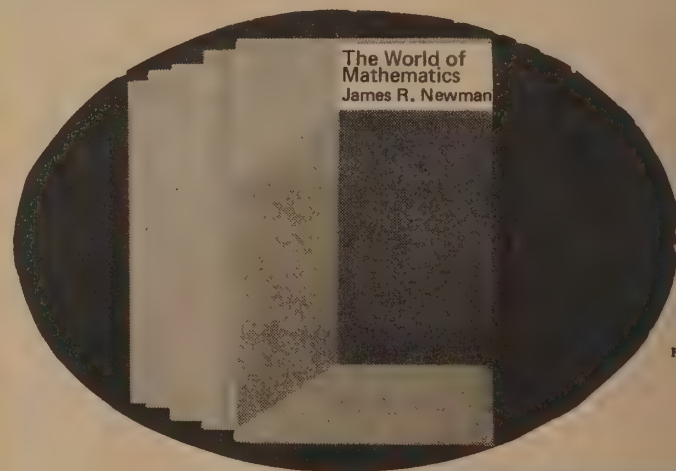

FIGURE 10-

2.5. CURVE

One very old method of expressing a curve and one which affords a welcome

The exterior perimeter of a net of a polyhedron which is all in one piece becomes a 'tree' of edges on the solid. This tree may be branched, but every edge is double and occurs twice on the perimeter of the net. It is evident that if these edges are numbered consecutively round the net every even edge will be joined to an odd edge in the final solid. This means that tabs need only be attached to the even edges. In the nets which follow, tabs are not shown unless there is special need to do so. In all other cases the rule is: attach tabs to alternate edges round the net.

There is an exception in the case of the last face, which is best left free of tabs. The missing tabs must be added to the other edges, and are best made large, so that a platform can be built up to which the last face can be stuck.

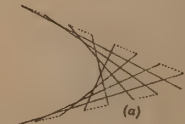

pencil and paper', is that of one originated in a book by Mrs. E. M. Whittaker, *Elementary Approach to Mathematics*, which has recently been revived, both in English and in French. Basically it consists of constructing a curve by stitching with coloured thread through pricked in cardboard.

of self-education math books. From them you can learn delight

Mathematics IS history and  
 infectious multi-faceted  
 stories—pure, applied,  
 a fine and complete  
 seen from outside.

Content, Methods,  
 Math from inside. A  
 technical run-down of  
 concern in mathematics

The Graphic Work of M. C. Escher is geometry set at its own throat via the images of dreams. The subjective frontier.

The New Mathematics Dictionary and Handbook is the handiest of handy reference books.

[Suggested by Lloyd Kahn]



The Graphic Work of M. C. Escher

M.C. Escher  
 1960, 68; 76 plates  
 \$7.95 postpaid

from:  
 Meredith Press  
 1716 Locust St.  
 Des Moines, Iowa 50303

or  
 WHOLE EARTH CATALOG

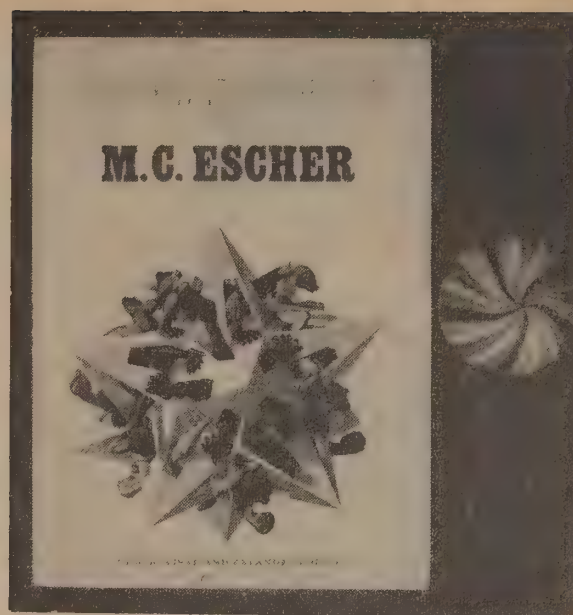

57. DOUBLE PLANETOID, wood-engraving, printed from 4 blocks, 1949, diameter 37.5 cm

Two regular tetrahedrons, piercing each other, float through space as a planetoid. The light-colored one is inhabited by human beings who have completely transformed their region into a complex of houses, bridges and roads. The darker tetrahedron has remained in its natural state, with rocks, on which plants and prehistoric animals live. The two bodies fit together to make a whole but they have no knowledge of each other.

...AS our mental eye penetrates into smaller and smaller distances and shorter and shorter times, we find nature behaving so entirely differently from what we observe in visible and palpable bodies of our surrounding that no model shaped after our large-scale experiences can ever be 'true'. A completely satisfactory model of this type is not only practically inaccessible, but not even thinkable. Or, to be precise, we can, of course, think it, but however we think it, it is wrong; not perhaps quite as meaningless as a 'triangular circle,' but much more so than a 'winged lion.'

ALOG

Mathematics: Its Content, Methods, and Meaning  
 A. D. Aleksandrov, A. N. Volmogorov, R. A. Lavrentev  
 1956, 1963; 1144 pp.; 3 vols.

\$10.00 postpaid

from:  
 The M. I. T. Press  
 Cambridge, Mass. 02142

or WHOLE EARTH CATALOG

III. There exists neither a point nor a line in the plane that is carried into itself under all the transformations of the group. Groups of this type are called plane Fedorov groups. They are the symmetry groups of infinite plane ornaments. There are altogether 17 of them: five consist of motions of the first kind only, and twelve of motions of the first and second kind.

In Table 3 we have given examples of ornaments corresponding to each of the seventeen plane Fedorov groups; every group consists of precisely those motions that carry an arbitrary flag drawn in the diagram into any other flag of the same diagram.

It is interesting to note that the masters of the art of ornamentation have in practice discovered ornaments with all possible symmetry groups; it fell to the theory of groups to prove that other forms do not exist.

Crystallographic groups. In 1890 the eminent Russian crystallographer and geometer E.S. Fedorov solved by group-theoretical methods one of the fundamental problems of crystallography: to classify the regular systems of points in space. This was the first example of a direct application of the theory of groups to the solution of an important problem in natural science and made a substantial impact on the development of the theory of groups.

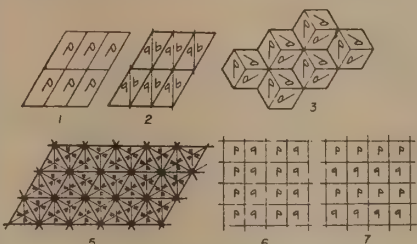

The New Mathematics Dictionary and Handbook  
 Robert W. Marks  
 1964; 186 pp.

\$ .95 postpaid

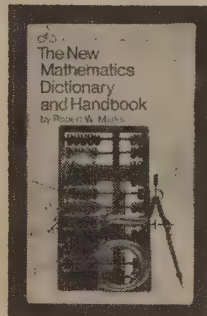

from:  
 Bantam Books, Inc.  
 271 Madison Ave.  
 New York, N. Y.  
 10016

or WHOLE EARTH CATALOG

VENN DIAGRAMS. Diagrams using overlapping circles to show relationships between sets; developed by John Venn (1834-1923), English logician. Each circle represents one set. Two or more may be overlapped. The areas of overlap (lens-shaped areas) indicate subsets which may contain elements common to both or all of the indicated sets. Some authors shade or cross-hatch the areas that contain members of a set; other authors use shading or cross-hatching to indicate emptiness. In the diagram below, shading indicates content.

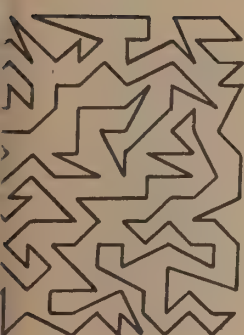

ch points of the plane are inside this polygon?

ATCHING  
 ion work in mathematics,  
 ange from 'the tyranny of

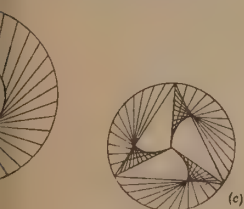

atching. It seems to have  
 mervell, entitled *A Rhyth-*  
 ublished in 1906. The idea  
 erica and in this country.  
 ng straight-line envelopes  
 through a pattern of holes

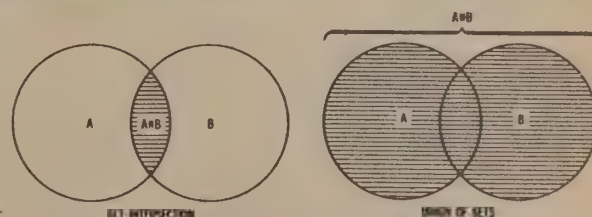
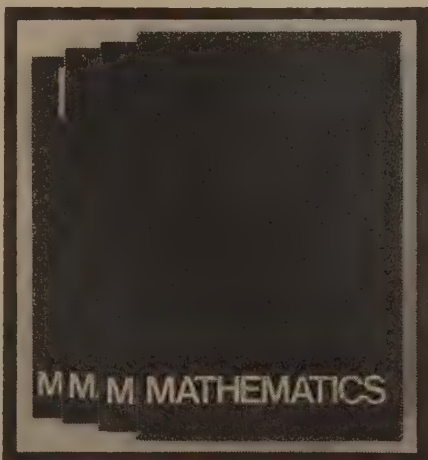

The shaded area represents that set of all elements that are both elements of A and elements of B.  
 Example: If A is the set of all students who take chemistry, and B is the set of all students taking physics, the shaded area is the set of all students taking both chemistry and physics.

The shaded area in the second diagram represents the set of all elements that are in A, or in B, or in both A and B.  
 Example: If A is the set of all men who own boats, and if B is the set of all fishermen, the shaded area indicates the set of all men who are boatowners or fishermen, or who are boat-owning fishermen.

★ **Economic Analysis**

*These two volumes by Boulding are tough and tedious, let's face it, unless you genuinely dig abstract concepts, intricate mathematical equations, and weird curves on charts.*

*So why bother? Here's one why: even if economics seems immoral, along with capitalism, and though you may think money is evil, you won't know how the world works until you are more than half smart about our economic system.*

*Another why: it is a constant surprise to me to discover that economics—as defined and portrayed by men like Boulding—represents one of the most artistically creative accomplishments of civilized man: a "whole system" par excellence. To be sure, there is a poignant irony in observing that greedy types in our society have largely monopolized the art of economics; perhaps as the gentle types begin to take a growing and serious interest in the subject we can anticipate a far better world in which to live.*

*A hyper-scholar in the field of economics will want more than Boulding offers. A "new economics" is already emerging, encompassing a cost-benefit orientation to problems of environmental pollution, overpopulation, and social misbehavior, etc.; and Boulding's books pre-date this new trend. Further, the fascinating field of money and banking (which is every bit as elegant a subject as dome architecture) is not covered by Boulding.*

*But Boulding will take you deep into the pleasures of demand, supply, consumption, prices, commodities, labor, wages, rent, trading, balance sheets, and economic organizations. You may exit from this trip with a lot more information on wheat crops than you care to use (man should not and can not live by "wheat economics" alone), but you will be unsurpassable when you lead your next confrontation into a dirty capitalist's office to demand a better world.*

[Reviewed by Richard Raymond]

• We may now define economics tentatively as the study of how society is organized through acts of exchange. [Vol. I]

It seems that what Mrs. Jones has really bought is not merely \$1.60 worth of butter, but 40 cents' worth of retailing, 20 cents' worth of wholesaling, 20 cents' worth of transport, 10 cents' worth of butter-making, 25 cents' worth of cattle feed, 10 cents' worth of depreciation of cows, 15 cents' worth of hired farm labor, and 20 cents' worth of farmer's labor. [Vol. I]

★ **Supply and Demand**

*A briefer, more classic, and earlier account of economic theory is Henderson's Supply and Demand.*

*Bear in mind that economists are created by economies, not vice versa very much. Who does create economies? You. If you don't like the one you're in, invent and perform a better one. Do it informed or do it innocent, either one beats passive complaint.*

[Suggested by Steve Baer]

- I. When, at the price ruling, demand exceeds supply, the price tends to rise. Conversely when supply exceeds demand the price tends to fall.
- II. A rise in price tends, sooner or later, to decrease demand and to increase supply. Conversely a fall in price tends, sooner or later, to increase demand and to decrease supply.
- III. Price tends to the level at which demand is equal to supply.

It has become an axiom of business men that, while Governments can manage with more or less competence a safe and routine business like a Postal Service, their success would be unlikely to prove conspicuous in undertakings where the element of risk is great. There, it is said, we owe everything in the past to the enterprise of individual men (for even joint-stock companies have not been notable as pioneers) adventuring their own fortunes in accordance with their own unfettered judgment.

**Supply and Demand**  
Hubert Henderson  
1922; 142 pp.  
**\$1.35** postpaid  
from:  
University of Chicago  
Press  
11030 South  
Langley Avenue  
Chicago, Illinois  
60628

or **WHOLE EARTH CATALOG**

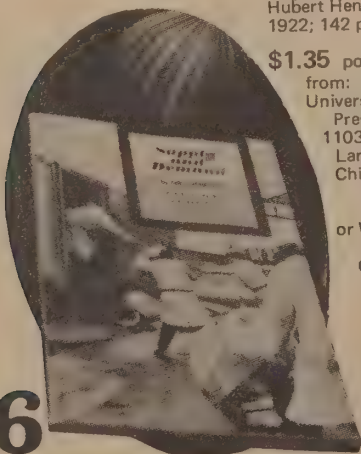

Exchange cannot take place unless there is specialization, for there would be nothing to exchange; but specialization without exchange would be useless, for the tailor would starve and the farmer go naked. Exchange without specialization is impossible; specialization without exchange is silly. [Vol. I.]

An exchange is not so much an equality (two pounds of butter=\$1.60) as two inequalities. Mrs. Jones thinks two pounds of butter are worth more to her than \$1.60, and the storekeeper thinks that \$1.60 is worth more to him than two pounds of butter. [Vol. I.]

The more of anything we have (under the condition that the quantities of all the other things we have remain the same), the less we want more of it. If we had only two ounces of sugar a week, we should greatly welcome an extra ounce. If, however, we had a hundred ounces of sugar a week, an extra ounce would make very little difference to us. [Vol. I.]

Things are valuable because somebody thinks they are, and for no other reason whatever.

There is indeed a dismal theorem, that if the only thing that can check the growth of population is starvation and misery, then population will grow until there is enough misery and starvation to stop its growth. Furthermore, there is an even more dismal theorem, which I have called the utterly dismal theorem, which states that if only starvation and misery can check the growth of population, then any improvement in the techniques of production will have the ultimate effect of increasing the total sum of human misery, for it will merely enable a larger population to exist in misery and starvation. [Vol. I.]

**DYNAMICS OF NEGATIVELY ELASTIC SUPPLY**

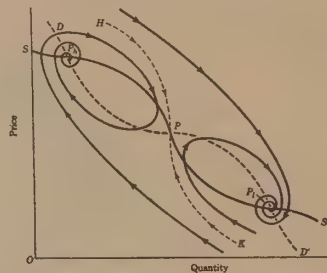
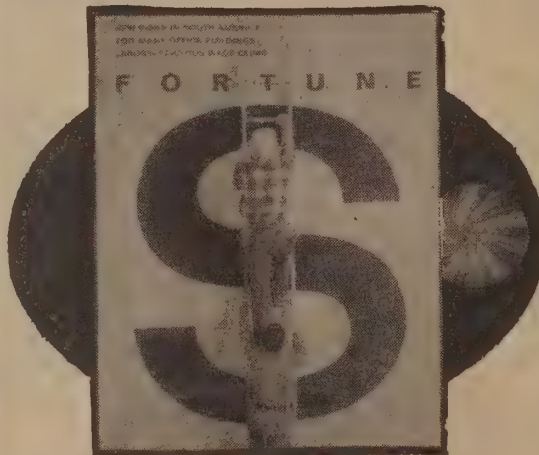

Fig. 64. Multiple Equilibria with Simultaneous Adjustments

It is interesting to apply this model to the case of the negatively elastic supply curve of Fig. 62. This is done in Fig. 64. It will be seen by examining the dynamic paths (lines marked with arrows) that the apparent Walrasian equilibrium at P is in fact unstable, and the two Marshallian equilibria at P<sub>h</sub> and P<sub>l</sub> are in fact stable. No matter how close a dynamic path comes toward P, say, from below to the left, it must cut SS' vertically from below and must swing round to cut DD' horizontally from the left. There is some line on the figure such as HPK which is the watershed: from all points to the left of this line the dynamic path eventually takes us to P<sub>h</sub>, or at least as close to it as we wish, and from all points to the right of it the dynamic paths all move toward P<sub>l</sub>. At any point on HP or KP the dynamic path moves to P, but this is a path of unstable final equilibrium in the sense that any random movement off the path to the right eventually lands up at P<sub>l</sub> and any movement to the left lands up at P<sub>h</sub>. [Vol. I.]

★ **Fortune**



*I started reading Fortune magazine after reading a lot of Buckminster Fuller because it was the only periodical with regular informative articles on his level of thinking (world shipping, construction, new industrial processes, natural resources, etc.). What I found was editing and reporting that made the contents of most popular American magazines look like so much paste.*

**Fortune**  
**\$14/yr** (monthly)

from:  
Fortune  
540 North Michigan Avenue  
Chicago, Illinois 60611

Many business leaders believe that they live in a racist society, that wealth is distributed unfairly, and that the nation needs spiritual regeneration. Most of all, they want no more wars.

A pure barter economy only seems to be possible where exchanges are rare and the commodities exchanged are highly diverse. As soon as anything like a market develops—that is, frequent and repeated exchanges of more or less standardized commodities—the principle of arbitrage will operate to bring the exchange ratios of various commodities into rough consistency with each other. When this happens it becomes possible to use one commodity as a measure of value, and a convention arises whereby prices are quoted in terms of the standard commodity, even though this may not participate in all exchanges. A great variety of such standard commodities have been used in different societies—cattle ("pecuniary" comes from the latin word Pecus, cow), seashells, beads, stones, tobacco, cloth, grain, and all the common metals. . . . The medium of exchange in a society, then, is that asset or group of assets which is wanted primarily because it is readily exchangeable. This attribute of ready exchangeability is called "liquidity." [Vol. II]



**Economic Analysis**  
Vol. 1: Microeconomics, 720 pp, **\$10.50** postpaid  
Vol. 2: Macroeconomics, 280 pp, **\$7.50** postpaid  
Kenneth E. Boulding  
1941, 1948, 1955, 1966

from:  
Harper & Row  
49 East 33rd Street  
New York, N. Y. 10016

or **WHOLE EARTH CATALOG**

★ **The Wall Street Journal**

*Far out. A daily newspaper with extensive reporting on sure-enough news. Not who murdered whom, but that a Free University in the Bay Area's midpeninsula is full of energy and new forms. Not what Mia Farrow thinks this month but a thorough appraisal of the occult market (mystical book sales up 100% in the last 3 years). In other words, the reporting of new trends, not old stories with new names.*

*The Wall Street Journal is in the thick of the stock market and kept honest by that involvement. You don't have to be in the market to use the paper.*

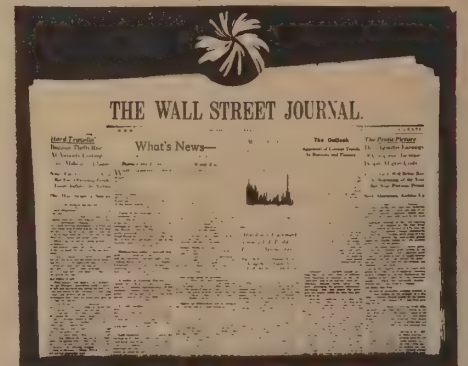

**The Wall Street Journal**  
**\$30/yr.** (daily); Overseas \$42

from:  
The Wall Street Journal  
30 Broad Street  
New York, N. Y. 10004

or  
The Wall Street Journal  
1701 Page Mill Road  
Palo Alto, CA 94304

★ **Curta Calculator**

*The Curta Calculator (made in Lichtenstein, no less) is one of those machine things that it would be nice to just have one around because it is so beautiful. It's tiny, but made in a way that discourages errors. It'll take poor climates without failure. Adds, subtracts, multiplies, divides, squares, cubes, takes square root, accumulates multiplications, multiplies or divides by constants. Rally navigators dig em, but so will anyone that needs a small calculator. Super in every respect. I've never talked to anyone that would part with his. Two models, \$125 and \$165, both about 2 1/2" x 3 1/2".*

[Suggested and reviewed by Jay Baldwin]

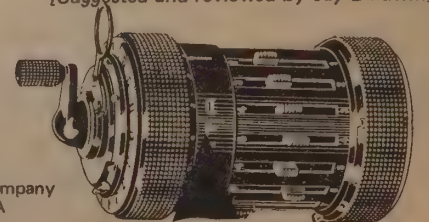

Literature

free

from:  
The Curta Company  
Van Nuys, CA

## Design for a Brain

This is a reputation review. Ashby's book is found prominent in the bibliography and footnotes of every text we've seen on computers and the mind. It's technical going to read but worth it for the insights of prime work.

Finding an optimum is a much more complex operation than finding a value that is acceptable (according to a given criterion). Thus, suppose a man comes to a foreign market containing a hundred kinds of fruit that are quite new to him. To find the optimum for his palate he must (1) taste all the hundred, (2) make at least ninety-nine comparisons, and (3) remember the results so that he can finally go back to the optimal form. On the other hand, to find a fruit that is acceptable he need merely try them in succession or at random (taking no trouble to remember the past), stopping only at the first that passes the test. To demand the optimum, then, may be excessive; all that is required in biological systems is that the organism finds a state or a value between given limits.

The development of life on earth must thus not be seen as something remarkable. On the contrary, it was inevitable. It was inevitable in the sense that if a system as large as the surface of the earth, basically polystable, is kept gently simmering dynamically for five thousand million years, then nothing short of a miracle could keep the system away from those states in which the variables are aggregated into intensely self-preserving forms.

This is the learning mechanism. Its peculiarity is that the gene-pattern delegates part of its control over the organism to the environment. Thus, it does not specify in detail how a kitten shall catch a mouse, but provides a learning mechanism and a tendency to play, so that it is the mouse which teaches the kitten the finer points of how to catch mice.

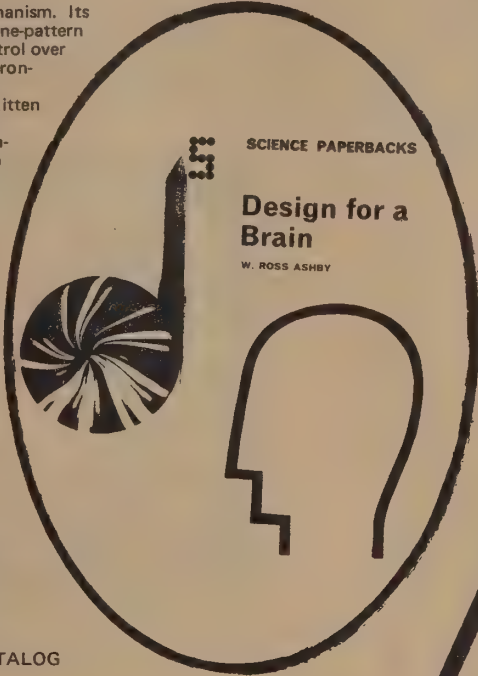

**Design for a Brain**  
W. Ross Ashby  
1952, 1960; 286 pp.

**\$2.50** postpaid

from:  
Barnes & Noble, Inc.  
105 Fifth Avenue  
New York, N. Y. 10003  
Economy Bookstore  
171 W. Madison  
Chicago, Illinois 60602

or WHOLE EARTH CATALOG

## Information

The September 1966 issue of Scientific American was devoted entirely to the new technology of information. Now available as a paperback book, it is the best introduction we've seen to computer science. Articles include: "Computer Logic and Memory", "Computer Inputs and Outputs", "Systems Analysis and Programming", "Time-sharing on Computers", "The Transmission of Computer Data", "The Uses of Computers in Technology", "The Uses of Computers in Organizations", "The Uses of Computers in Education", "Information Storage and Retrieval", and "Artificial Intelligence".

**Information**  
1966; 218 pp. from:  
**\$2.50** postpaid W. H. Freeman & Company  
660 Market Street  
San Francisco, CA 94104

or WHOLE EARTH CATALOG

The computer is almost exactly what man is not. It is capable of paying undivided attention to unlimited detail; it is immune to distraction, precise and reliable; it can carry out the most intricate and lengthy calculation with ease, without a flaw and in much less than a millionth of the time that would be required by its human counterpart. It is emotionless, or so we suppose. It suffers neither boredom nor fatigue. It needs to be told only once; thereafter it remembers perfectly until it is told to forget, whereupon it forgets instantly and absolutely.

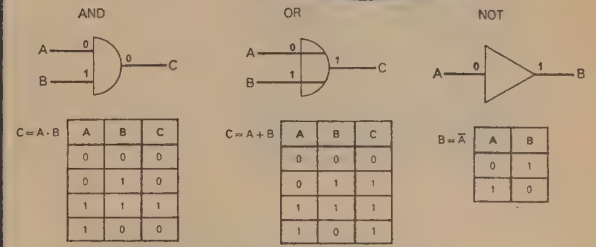

Simulated waterfall spills over the edge of a cliff and splashes into a pool in this computer experiment performed by John P. Shannon at the Los Alamos Scientific Laboratory as part of a study of dynamic behavior of fluids with the aid of numerical models.

## Handbook of Mathematical Functions

Designed for the person who needs but does not have access to powerful computer facilities, this Government bargain is a modernized version of the classical tables of functions of Jahnke-Emde.

[Suggested by Mrs. W. B. Mohin]

### CONTENTS

1. Mathematical Constants
2. Physical Constants and Conversion Factors
3. Elementary Analytic Methods
4. Elementary Transcendental Functions  
Logarithmic, Exponential, Circular and Hyperbolic Functions
5. Exponential Integral and Related Functions
6. Gamma Function and Related Functions
7. Error Function and Fresnel Integrals
8. Legendre Functions
9. Bessel Functions of Integer Order
10. Bessel Functions of Fractional Order
11. Integrals of Bessel Functions
12. Struve Functions and Related Functions
13. Confluent Hypergeometric Functions
14. Coulomb Wave Functions
15. Hypergeometric Functions
16. Jacobian Elliptic Functions and Theta Functions
17. Elliptic Integrals
18. Weierstrass Elliptic and Related Functions
19. Parabolic Cylinder Functions
20. Mathieu Functions
21. Spheroidal Wave Functions
22. Orthogonal Polynomials
23. Bernoulli and Euler Polynomials, Riemann Zeta Function
24. Combinatorial Analysis
25. Numerical Interpolation, Differentiation and Integration
26. Probability Functions
27. Miscellaneous Functions
28. Scales of Notation
29. Laplace Transforms

**Handbook of Mathematical Functions With Formulas, Graphs, and Mathematical Tables**  
1964, 1968; 1046 pp.

**\$6.50** postpaid

from:  
Superintendent of Documents  
U. S. Government Printing Office  
Washington, D. C. 20402

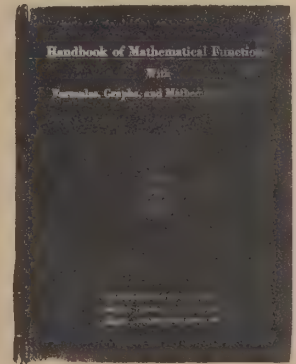

## Desk-top Calculators

The Hewlett-Packard 9100A is now \$4400. If you have to deal with problems which require a considerable capacity then the Wang 700 should be a great deal better than the HP since its total memory under program control (core plus tape) will be about 70 times as much as HP's. For people that order a 700 before it is being produced Wang loans a 370 with two card readers, a system which in some ways is already better than the HP. Such a 370 system costs \$4700.

Deficiencies of 370 compared with HP:

- Much slower
- Does not have wired in programs for trig functions and some other functions (but programs can be fed in on cards)
- Can not handle as wide a range of numbers (only from about  $10^{-10}$  to  $10^{+9}$  instead of nearly  $10^{-100}$  to  $10^{+100}$ )
- Much less convenient to write and correct programs
- Results of a computation cannot be read out onto a magnetic card or tape for later use (this can be done on the HP altho the salesman may not realize it)
- Not as good a display

Advantages of 370 compared with HP:

- Greater capacity (28 registers compared to 19 for HP with no program, with 160 step program 370 still has 28 registers but HP has only 7—160 steps is maximum size program for 370 with two card readers without feeding cards in manually, compared to 196 for HP but another card reader would bring it up to 240)
- Ability to use subroutines (but not subroutines within subroutines)—with HP a subroutine must be rewritten every place it is used in the main program thus using up precious capacity.

The 700 should be as good or better in all these respects, except the display, as well as having some other big programming advantages—particularly indirect addressing of registers in which the computer decides which register to go to thus saving much capacity as well as making programs easier to write.

[Reviewed by Craig Schensted]

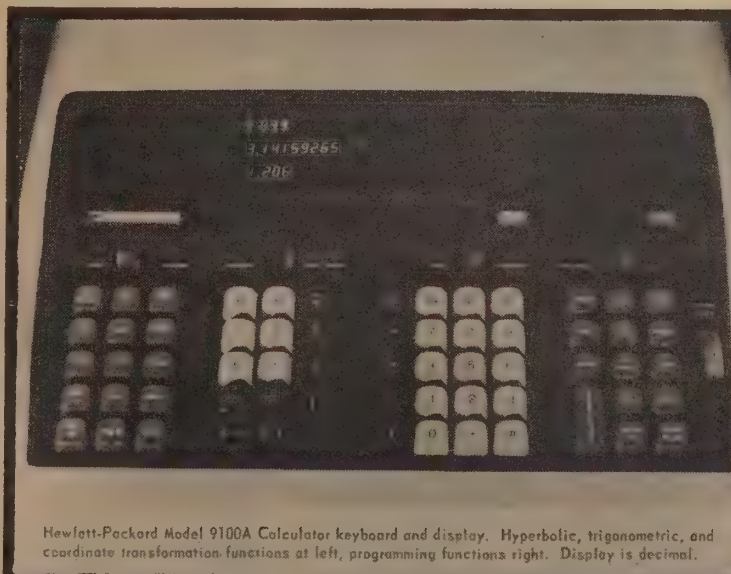

Hewlett-Packard Model 9100A Calculator keyboard and display. Hyperbolic, trigonometric, and coordinate transformation functions at left, programming functions right. Display is decimal.

Hewlett-Packard information from:  
P. O. Box 301  
Loveland, Colorado 80537



Wang information from:  
Wang Laboratories, Inc.  
836 North Street  
Tewksbury, Mass. 01876

★ **Art and Illusion**

So much art criticism is so much a vapid waste of time that a book like this one is thoroughly a shock. Every page yields fresh information (did you know that the comic strip was singlehandedly invented by a Swiss gent named Töpfler in the 1820's?) and worthwhile hypotheses about how art and artists gradually teach themselves energies of effect. Furthermore the book is a bargain—it has 319 fine illustrations, 18 in color.

**Art and Illusion**  
E. H. Gombrich  
1960, 1961; 466 pp.  
**\$5.95** postpaid

from:  
Princeton University Press  
Princeton, New Jersey 08540

or **WHOLE EARTH CATALOG**

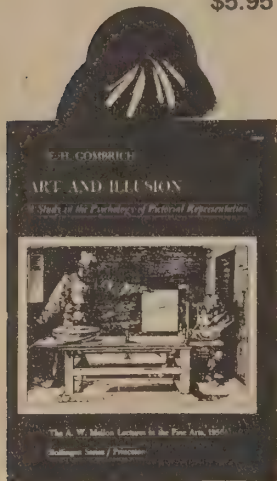

Only in the realm of dreams has the artist found full freedom to create. I think the difference is well summed up in the anecdote about Matisse. When a lady visiting his studio said, "But surely, the arm of this woman is much too long," the artist replied politely, "Madame, you are mistaken. This is not a woman, this is a picture."



But no tradition of art had a deeper understanding of what I have called the "screen" than the art of the Far East. Chinese art theory discusses the power of expressing through absence of brush and ink. "Figures, even though painted without eyes, must seem to look; without ears, must seem to listen. . . . There are things which ten hundred brush-strokes cannot depict but which can be captured by a few simple strokes if they are right. That is truly giving expression to the invisible." [170] The maxim into which these observations were condensed might serve as a motto of this chapter: "i tao pi pu tao—idea present, brush may be spared performance."

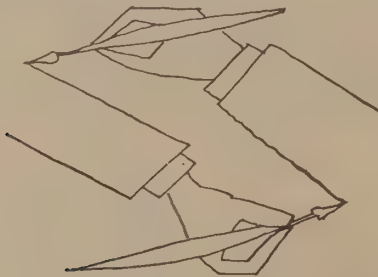

202 **STEINBERG:** From "The Passport"

Max Friedländer tells the revealing story of the bank official who insisted that German bank notes should retain a portrait head in their design. Nothing, he said, was harder for the forger to imitate than precisely the right expression of these artistically quite insignificant heads, nor was there a quicker way of discovering a suspect note than simply observing the way these faces look at you.

★ **The Très Riches Heures of Jean, Duke of Berry**

If you are at a place in your life where images can affect you, level this book at your head. It has 139 color plates, incomparable, exquisite, razor-edged. There is nothing like it in history.



**The Très Riches Heures of Jean, Duke of Berry**  
1485, 1969; 139 plates and text.

**\$30.00** postpaid until 25 December 1969; **\$35.00** thereafter

from:  
George Braziller  
1 Park Avenue  
New York, N. Y. 10016

or **WHOLE EARTH CATALOG**

In this emphasis on elimination of false guesses, on trial and error in all acquisition of knowledge "from the amoeba to Einstein," I am following K. R. Popper. It would be tempting to take up the problems of Gestalt psychology from this angle, for Popper emphasizes that the assumption of regularity is of the utmost biological value. A world in which all our expectations were constantly belied would be a lethal world. Now in looking for regularities, for a framework or schema on which we can at least provisionally rely (though we may have to modify it for ever), the only possible strategy is to proceed from simple assumptions. Popper has shown that paradoxically this is not due to the fact that a simple assumption is more probably right but because it is most easily refuted and modified.

Rabbit or duck?



True, we can switch from one reading to another with increasing rapidity; we will also "remember" the rabbit while we see the duck, but the more closely we watch ourselves, the more certainly we will discover that we cannot experience alternative readings at the same time. Illusion, we will find, is hard to describe or analyze, for though we may be intellectually aware of the fact that any given experience must be an illusion, we cannot, strictly speaking, watch ourselves having an illusion.



269 **AL CAPP:** The Shmoo

★ **Brain Storms**

Dr. Barker presents a fascinating argument that epileptic fits and fits of creativity are very closely related and both are brought on by unusual threats to continuity in brain function, requiring a massive "storm" of re-organization in the brain. The fit is an attempt to in fact fit together incompatible considerations which have collided. I believe it, in part because Barker makes his case so well, in part because it sounds like what I've experienced.

**Brain Storms—A Study of Human Spontaneity**  
Wayne Barker, M. D.  
1968; 277 pp.

**\$2.95** postpaid from:  
Grove Press, Inc.  
80 University Place  
New York, N. Y. 10003

or **WHOLE EARTH CATALOG**

A fit, even the grossest major convulsive fit of epilepsy, is many things happening at once. Fits are patterns of awareness and action, combinations of knowing, feeling, and doing. They are episodes of behavior and experience put together by the brain during crises in the continuity of living. Such crises are characterized by a sudden coming together of a complex of conflicting and disparate ideas, images, and impulses; fits are syntheses of such complexes that both resolve and represent their otherwise unthinkable contradictions and ambiguities. By providing more or less fitting resolutions of crises, fits serve to maintain or restore the crisis-disrupted continuity of transactions between organism and environment.

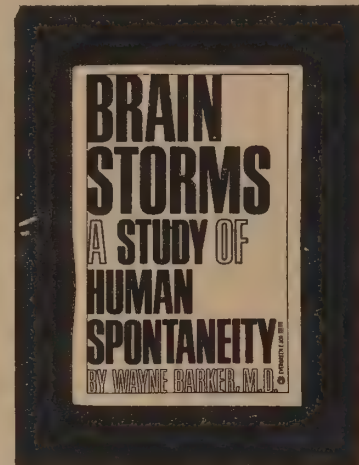

. . . if we can endure confrontation with the unthinkable, we may be able to fit together new patterns of awareness and action. We might, that is, have a fit of insight, inspiration, invention, or creation. The propensity for finding the answer—the lure of creating or discovering the new—no doubt has much to do with some people's ability to endure tension until something new emerges from the contradictory and ambiguous situation.

xii **Contents**

- 27. "... I Know That It Is Poetry"  
Fits of Gooseflesh, Shivering, the "Top of My Head Coming Off," and Other Reactions Precipitated by Poetic Versions of Uncanny Experience.
- 28. "... Thoughts Crowd into My Mind . . . Whence Do They Come?"  
A Fit of Composing, A Creative Minding of a Dysjunctive Flood of Ideas.
- 29. **Taking a Talking-Taking Walk**  
A Fit in Which a Major Convulsive Reaction Is Transformed into a Sequence of Anger, Coughing, Laughing, and Wit.
- 30. "Z, Y, X, W, V . . ."  
A Fit of "Trying to See" the Answer to an Experimental Problem.
- 31. "Oh, Yeah? If You Know So Much, When'll the War Be Over?"  
A Fit of Unintended Prophecy.
- 32. **A Morose Secretary**  
A Fit of Symbolization, Condensation, and Hallucination While Trying to Think.
- 33. **Perspiration and Inspiration**  
The Interaction of Intention and Spontaneity in Complex Sequential Fits of Creation.
- 34. "Suddenly I Felt a Misty Consciousness as of Something Forgotten . . . Everything Had a Name"  
A Fit of Spelling, of Recognition, and of Sudden Fitting Together.

What we need is to let the fitting-together capacity of the human brain operate at least occasionally in freedom from the narrow, provincial, egoistic concerns of "I" and "Us." The essence of our contemporary crisis is simple: Most people in the world want to have modestly human food, shelter, and an opportunity to care decently for their children. The technological and material means for satisfaction of these wants exist. Not much of a "dream" is required to get it done. No longer will any conventional evasion or caricatured "solution" suffice. The only possible outcomes now are convulsive or creative. It all depends upon our commitment.

184 **The Concepts of Dysjunctive Situations**

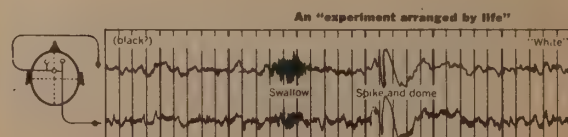

**Eye and Brain**

*I can't think of another book as well-made as this one. It is well designed, illustrated, and diagrammed. The writing is excellent, the subject matter important and new. The book is inexpensive. Altogether Eye and Brain lets you see how crappy most books are.*

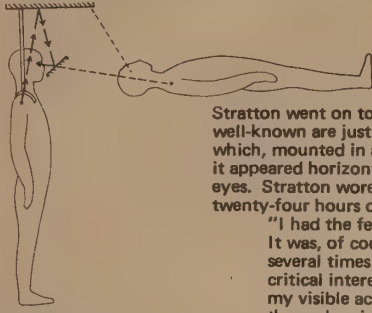

Stratton went on to perform other experiments which though less well-known are just as interesting. He devised a mirror arrangement which, mounted in a harness, visually displaced his own body, so that it appeared horizontally in front of him, and at the height of his own eyes. Stratton wore this mirror arrangement for three days (about twenty-four hours of vision) and he reported:

"I had the feeling that I was mentally outside my own body. It was, of course, but a passing impression, but it came several times and was vivid while it lasted. . . . But the moment critical interest arose, the simplicity of the state was gone, and my visible actions were accompanied by a kind of wraith of themselves in the older visual terms.

Why should the perceptual system be as active in seeking alternative solutions as we see it to be in ambiguous situations? Indeed it seems more active, and more intellectually honest in refusing to stick with one of many possible solutions, then in the cerebral cortex as a whole—if we may judge by the tenacity of irrational belief in politics or religion. The perceptual system has been of biological significance for far longer than the calculating intellect. The regions of the cerebral cortex concerned with thought are comparatively juvenile. They are self-opinionated by comparison with the ancient striate area responsible for vision.

Held found that only the active kitten developed perception, the passive animal remaining effectively blind. He thus suggested that active touch is essential to perceptual development.

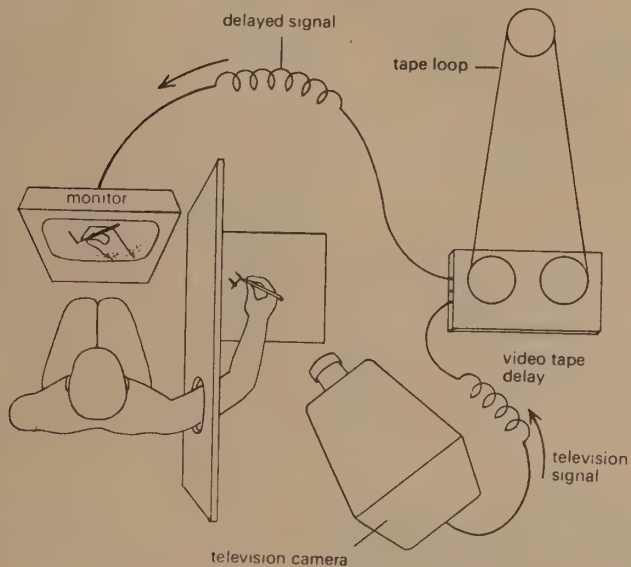

An elaboration of the television technique makes it possible to displace retinal images not only in space, but in time. Temporal delay of images is a new kind of displacement, and promises to be of the greatest importance. The method is to use a TV camera and monitor, with an endless tape loop so that there is a time-delay between the recording from the camera and the playback to the monitor. The subject thus sees his hands (or any other object) in the past; the delay being set by the gap between the Record and Play-back heads.

This situation is not only of theoretical interest, but is also of practical importance because controls used in flying aircraft, and operating many kinds of machine, have a delay in their action: if such delay upsets the skill, this could be a serious matter. It was found that a short delay (about 0.5 seconds) made movements jerky and ill co-ordinated, so that drawing became almost impossible, and writing quite difficult. Practice gives little or no improvement.

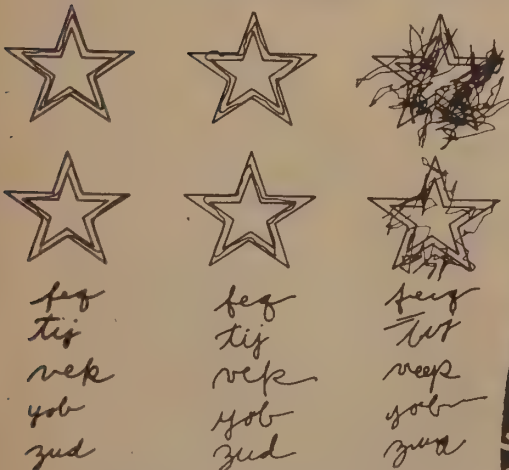

**Eye and Brain — The Psychology of Seeing**  
R. L. Gregory  
1966; 254 pp.

**\$2.45** postpaid from:  
McGraw-Hill Book Company  
Princeton Road  
Hightstown, N. J. 08520  
Manchester Road  
Manchester, Missouri 63062  
8171 Redwood Highway  
Novato, CA 94947

or WHOLE EARTH CATALOG

**★ Physical Control of the Mind**

*I do not like this guy. He has insufferable hubris and he tramples on all my fondest notions about the independent life of the mind. Consequently he is highly useful to me. The book is full of harsh physical evidence and harsh hypotheses that I have got to either surround or accept (or quit). Thanks, jerk.*

Pleasure is not in the skin being caressed or in a full stomach, but somewhere inside the cranial vault.

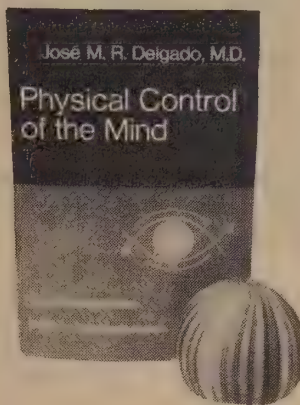

**Physical Control of the Mind**  
Jose M. R. Delgado, M. D.  
1969; 280 pp.

**\$7.95** postpaid

from:  
Harper & Row, Publishers  
49 E. 33rd Street  
New York, N. Y. 10016

or WHOLE EARTH CATALOG

When the patient was warned of the oncoming stimulation and was asked to try to keep his fingers extended, he could not prevent the evoked movement and commented, "I guess, Doctor, that your electricity is stronger than my will."

The old dream of an individual overpowering the strength of a dictator by remote control has been fulfilled, at least in our monkey colonies, by a combination of neurosurgery and electronics, demonstrating the possibility of intraspecies instrumental manipulation of hierarchical organization. A monkey named Ali, who was the powerful and ill-tempered chief of a colony, often expressed his hostility symbolically by biting his hand or by threatening other members of the group. Radio stimulation in Ali's caudate nucleus blocked his usual aggressiveness so effectively that the animal could be caught inside the cage without danger or difficulty. During stimulation he might walk a few steps, but he never attempted to attack another animal. Then a lever was attached to the cage wall, and if it was pressed, it automatically triggered a five seconds' radio stimulation of Ali. A female monkey named Elsa soon discovered that Ali's aggressiveness could be inhibited by pressing the lever, and when Ali threatened her, it was repeatedly observed that Elsa responded by lever pressing. Her attitude of looking straight at the boss was highly significant because a submissive monkey would not dare to do so, for fear of immediate retaliation. The total number of Ali's aggressive acts diminished on the days when the lever was available, and although Elsa did not become the dominant animal, she was responsible for blocking many attacks against herself and for maintaining a peaceful coexistence within the whole colony.

The brontosauri became extinct because of their extremely limited mental powers; faced with an increasingly unfavorable climate and diminishing food supply, these animals were incapable of adaptation and could not survive in the changing environment.

The fate of these giants may have symbolic value for twentieth century civilization, which is also attempting to direct tremendous potential with disproportionately small brains. While our mental faculties are incomparably superior to those of the early land animals, we still lack adequate self-knowledge and control, and natural history teaches that when underdeveloped brains are in charge of great power, the result is extinction.

In my opinion, without stimuli (or without the brain), the mind cannot exist; without behavior, the mind cannot be recognized. Because of its essential dependence on sensory inputs, both at birth and throughout adult life, the mind may be defined as the intracerebral elaboration of extracerebral information. The problem is then focused on the origins, reception, dynamics, storage, retrieval, and consequences of this information. The basis of the mind is cultural, not individual.

The newborn brain is not capable of speech, symbolic understanding, or of directing skillful mobility. It has no ideas, words, or concepts, no tools for communication, no significant sensory experience, no culture. The newborn baby never smiles. He is unable to comprehend the loving phrases of his mother or to be aware of the environment. We must conclude that there are no detectable signs of mental activity at birth and that human beings are born without minds.

... the microneurons of the cerebellum, which serve as association elements, develop after birth under the influence of the infant's behavioral activities. Therefore it can be said that the environment is absorbed as a structural part of the neurons in the developing brain.



Watching a rat or monkey stimulate its own brain is a fascinating spectacle. Usually each lever pressing triggers a brief 0.5-to 1.0-second brain stimulation which can be more rewarding than food. In a choice situation, hungry rats ran faster to reach the self-stimulation lever than to obtain pellets, and they persistently pressed this lever, ignoring food within easy reach. Rats have removed obstacles, run mazes, and even crossed electrified floors to reach the lever that provided cerebral stimulation.

It is surprising that in science as well as in literature more attention has been paid to suffering than to happiness. The central theme of most novels is tragedy, while happy books are hard to find; excellent monographs have been published about pain; but similar studies of pleasure are nonexistent.

One of the moving pictures taken in this study was very demonstrative, showing a patient with a sad expression and slightly depressed mood who smiled when a brief stimulation was applied to the rostral part of the brain, returning quickly to his usual depressed state, to smile again as soon as stimulation was reapplied. Then a ten-second stimulation completely changed his behavior and facial expression into a lasting pleasant and happy mood. Some mental patients have been provided with portable stimulators which they have used in self-treatment of depressive states with apparent clinical success.

- (1) **Lack of predictability:** When a point of the brain is stimulated for the first time, we cannot predict the effects which may be evoked. . . .
- (2) **Lack of purpose:** In some cases the evoked response is directed by the animal in a purposeful way, but the movements and sequential responses are usually out of context, and there is no reason or purpose for yawning, flexing a hand, or walking around, apart from ESB. . . . [Electrical Stimulation of the Brain]
- (3) **No robot performance:** Brain stimulation activates cerebral mechanisms which are organized for motor performance, but it cannot replace them. With the present state of the art, it is very unlikely that we could electrically direct an animal to carry out predetermined activities such as opening a gate or performing an instrumental response. We can induce pleasure or punishment and therefore the motivation to press a lever, but we cannot control the sequence of movements necessary for this act in the absence of the animal's own desire to do so.

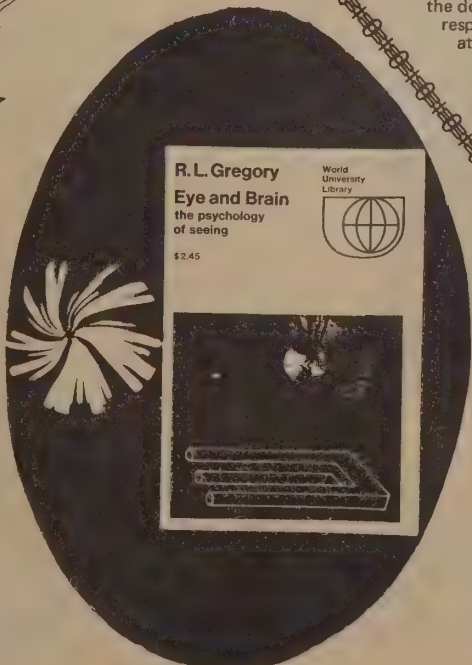

Accurate, specific information on what's new in equipment, techniques, standards, and the attitudes of technicians using them. Also gossip and news about who's doing what where. Covers all aspects of professional filmmaking from Hollywood Super Panavision 70mm to 8mm educational loops. The ads, fully as important as the text, are mouthwatering for those with an appetite for Eclairs and such. If you read it regularly you'll never need Baddeley—you'll know how it's really done. Often the information is directly and simply usable; sometimes it stimulates visions of the super-cinema of the future. When in school I consulted back issues for a psychology paper on perception. The articles are really interesting and, best of all, there is no film criticism so you avoid all those negative emotions.

[Suggested by Gordon Ashby  
Reviewed by Sandra Tcherepnin]

American Cinematographer  
\$6.00 for one year (monthly)

from:  
American Cinematographer  
1782 North Orange Drive  
Hollywood, California  
90028

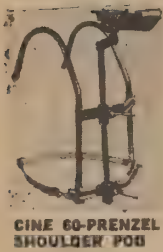

CINE 60-PRENZEL SHOULDER POD

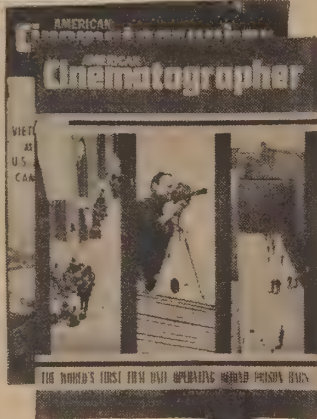

# eclair

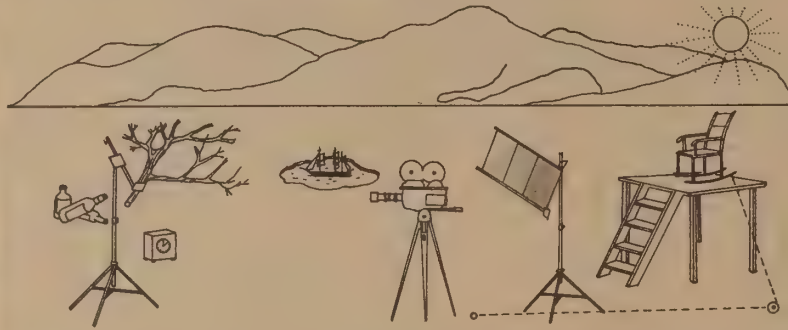
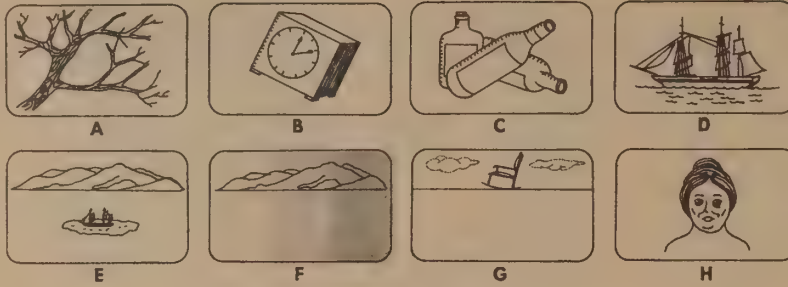

Diagrams illustrating one of the most complicated continuous scenes in the film, a dream fantasy photographed in Death Valley. (TOP) A—Dissolve in to out-of-focus bush, which then racks into focus. B—Focus racks through bush to big closeup of clock. C—Camera pans to bunch of bottles in snow. D—Camera pans to close shot of yacht in water. E—Zoom lens racks back to reveal yacht as miniature model floating in puddle-sized desert pond. F—Camera pans landscape through series of three progressively denser 85 orange gels. G—Camera comes to rest on ghostly sunset shot of chair rocking on horizon. E—Scene dissolves to "Oedipus type" closeup of character's mother. (BELOW) Diagram of the complicated set-up for filming scene in Death Valley. Remote cord arrangement made possible rocking of chair from camera position.

Toward the end of Stanley Kubrick's "2001: A SPACE ODYSSEY"—in that somewhat psychedelic sequence audiences like to call "the trip"—there are scenes in which the camera seems to be speeding through flat corridors having walls made up of multi-colored abstract patterns of light, an effect which we called the "Star-gate" while we were working on it.

The slit scan camera mechanism incorporates a normal motion picture camera equipped with a stop motion motor, along with various selsyn motors and timers, to produce the streak photograph frame by frame as mentioned in the summary of the slit scan technique. The most important part of the mechanism is the motion picture camera. The normal shutter mechanism within the camera is taken 180° out of phase so that between frames in the stop motion sequence, the shutter remains in the open position. The exposure is then controlled by the auxiliary diaphragm-type shutter in front of the lens which is activated by the main sequencer.

We got down there and I took about three deep breaths and said, "It's melting! It's melting! It's melting! The light is just right. Strip, baby!" I climbed into all this camera equipment and this poor young lady went running in the nude in about a 33° temperature and we got the thing in one take.

2. Moving one step and several hundred dollars up, we come to the production camera. This camera is best typified by the Arriflex and Eclair. Both have registration pin movements to assure rock-steady image quality. Both are widely adaptable, by means of accessories, to cope with varying assignments.

In cameras of this type, you will always find electric motor drives, usually interchangeable, to allow an extra-ordinary range of speeds and applications.

Also, cameras of this type have interchangeable magazines, so the film maker can shoot whatever emulsion he chooses, switching as the need occurs, without inconvenience.

## American Cinematographer Manual

Indispensable data book, used by American cinematographers. Expensive, because it is absolutely comprehensive, up to date, from Hollywood, and has no competitors.

American Cinematographer Manual  
Joseph V. Mascelli, A.S.C., ed.  
newest edition 1969; approx. 600 pp.

\$15.00 postpaid

from:  
The American Cinematographer Manual  
P.O. Box 2230  
Hollywood, California 90028

or WHOLE EARTH CATALOG

More than 600 pocket-size pages of concise, practical, informative text, tables, charts, diagrams, drawings and listings of all the latest production equipment and filming techniques in use today! Key word printed on the edge of every right-handed page provides INSTANT INDEX for quickly locating desired data!

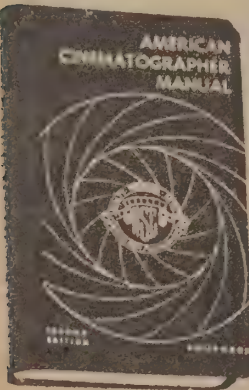

## Behrend's Book

One disadvantage of mail order is that you don't get to rap with the clerk and find out how to use the thing you're buying. That disadvantage is somewhat overcome in this catalog of film equipment (sales and rental). They explain matters more than is usual with remote merchants.

Behrend's Book  
1969; 108 pp.

free

from:  
Behrend's Incorporated  
161 East Grand Avenue  
Chicago, Illinois 60611

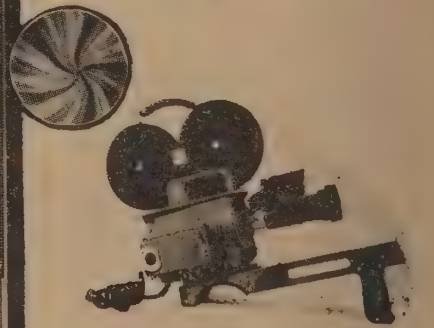
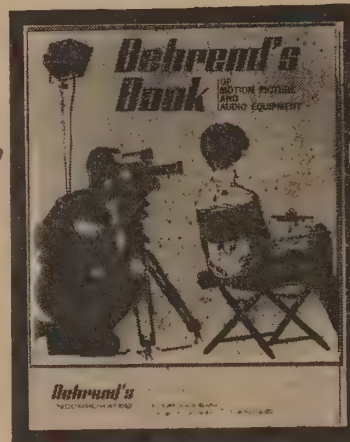

## Behrend's Information for Film Editors

Marking Workprints to Indicate Effects



PREPARATION OF ORIGINAL A AND B ROLLS

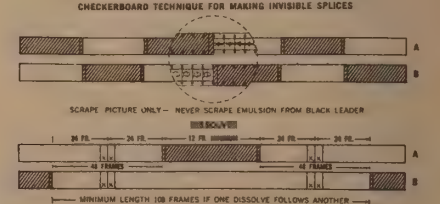

## Avoiding Paper Rustle

There is, for instance, that very basic requirement of ensuring that the turning of pages or the rustling of the script is not picked up by the microphone. This is usually got around by mounting the pages of the script separately on cardboard. There is still the problem of how to attach the sheets to the boards. Rubber bands are commonly used, but they can become caught in the adjacent board and emit a loud "twang"! Paper clips are an alternative, but there is a great tendency for one board to become attached beneath the clip on the next just at the moment when it is necessary to move quickly to a fresh page. A possibility is to use an adhesive such as Cow gum, but this may take longer. An ingenious alternative is to type the script on blotting paper which will not, of course, rustle. The drawback here is that it is not easy to take a carbon copy when typing on blotting paper—unless the blotting paper is the carbon copy, in which event the commentator may not find it clear enough to read.

## The Technique of Documentary Film Production

Try not to be put off by the word "documentary."

This is a book for times when you are starved for some lean and specific information. It covers all conventional aspects of filmmaking: subtle items, which can really best be learned by the experience of seeing and working on films (use of dissolves, effect of different lens lengths, etc.); necessary conventions, like systems of marking workprints, and technical facts about equipment; and the hundreds of little hints and tricks, some whimsical some incredibly mundane, which technicians have hit upon by trial, error and inspiration over the years. All of these are discussed in the same thorough, detached, insensitive way. But at least the basic information is there so you can get it if you need it. This book will not help you to learn filmmaking—you'll have to bring along the enthusiasm and involvement—so start filming and then use it when you have to.

[Reviewed by Sandra Tcherepnin]

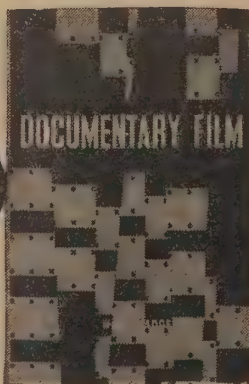

## The Technique of Documentary Film Production

Hugh Baddeley  
1963; 268 pp.

\$10.00 postpaid

from:  
Communications Arts Books  
Hastings House Publishers, Inc.  
10 East 40th Street  
New York, N. Y. 10016

or WHOLE EARTH CATALOG

If we see a man in medium shot and then take a closer look at him in close-up, he must be in the same position in both shots—or, to be more precise, he must be in the same position at the end of the medium shot as when we cut to him at the beginning of the close up. In real life this would automatically be so; when we film him we must somehow ensure that it is so despite the fact that, in changing our lens or camera position, there has been a lapse of time. On the face of it, this point appears obvious. It is all the more surprising, therefore, that many beginners fail to appreciate it and assemble their shots with serious continuity errors between them, thinking that the audience will not be bothered by them.



**Tape recorders**

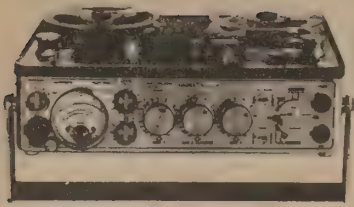

The top of the heap in sound recording is Nagra. Their prices start at \$1123.

For general purpose high-quality mobile recording, the Uher 4000 L is still in front of everyone else for reliability and economy (approx \$440.). The new Uher 1000 Report Pilot, designed for sound/film synchronization, costs about \$695.

For access, try local dealers and compare with Behrend's, (p. 69).



Portable listening is another matter entirely than recording. Here I'm inclined to agree with Bob Fass that cassette is the medium and Sony the manufacturer. Specifically, the TC 124 (stereo, w/o extra speakers): \$149.



**King Karol Records**

This looks like the best mail order source of records. They send you a comprehensive Schwann catalog to order from. Fairish discounts, postage paid. They also carry pre-recorded and blank tapes, cartridges, and cassettes. Now the question is how quick and reliable are they?

[Suggested by Lloyd Martin]

Catalog free

from: King Karol Records  
P. O. Box 629  
Times Square Station  
New York, N. Y. 10036



ALL ORDERS IN THE U.S.A., A.P.O. AND F.P.O. ORDERS FREE OF MAILING AND HANDLING CHARGES (Add 15% for all other foreign handling and mailing—minimum charge \$1.50)

SCHWANN CATALOG MAILED FREE ON REQUEST

Schwann Catalog List Prices	Your Discount Price	Schwann Catalog List Prices	Your Discount Price
\$1.98	\$1.55	\$3.98	\$2.75
2.50	1.85	4.98	3.35
2.98	2.20	5.98	4.16
		6.98	4.65

PLEASE NOTE: N. Y. RESIDENTS ADD TO THE ABOVE PRICES THE NEW YORK CITY OR STATE SALES TAX

**Horns, Strings, and Harmony**

This is a very clear and fairly comprehensive introduction to musical physics, with suggestions for experiments to be performed by the reader at home. It is a paperback of 260 pages with a good bibliography for further study. The author is a physicist and musician; the book is written for musicians and amateur physics teachers.

There are three main divisions of subject matter:

- 1) Theoretical discussions of the principles of vibration, Chapters II, III, and VII
- 2) Practical applications, Chapters IV and V — the physics of hearing Chapters VI, VIII, and IX — instrumental design (strings, brass, woodwinds)
- 3) Homemade wind instruments, Chapter X.

Familiarity with algebraic concepts is necessary throughout; access to musical instruments is helpful. Most of the experiments can be done at home without too much difficulty or expense (whistles, string, beads, etc.). The chapter on homemade instruments is for accomplished wind instrumentalists who are also confident with hand tools.

[Reviewed by Peter Lynn Sessions. Suggested by Allen Watson III]

Thus we see that the real test of a good violin is not in the ears of the listener, but rather in the hands of the player. If he can get the range of effects he wants, without strain, then he has a good instrument. Except in a minor way, by clearing away some of the most obvious stupidities, physics has not been able to help him very much more than has the witchcraft that has grown up lush and rank around this beautiful instrument.

Once again the flute is different from other woodwinds; it needs no bell for two reasons: first because the vibration recipe of any flute, old or new in style, is so lacking in the higher components that very little sound energy is present above the change-over frequency, and second, the very large holes of the modern Boehm flute serve to cut off the tube so effectively that all the notes think of themselves as coming out of the end of an ordinary pipe!

**Horns, Strings, and Harmony** from: Arthur H. Benade Doubleday & Co. 501 Franklin Garden City, N. Y. 11531

\$1.45 postpaid

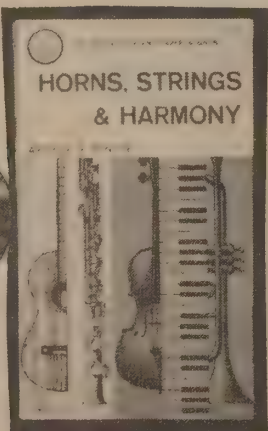

72

**King Karol Records**

**Moog Synthesizer**

*New instruments → new music, and nothing can be done about it except fight or flow. Multi-channel sound recording studios are one new instrument. The Moog synthesizer is another. The following are excerpts from Edmund O. Ward's excellent review of Moog in the 3 May 69 Rolling Stone.*

[Suggested by Lloyd Kahn]

Fifteen years ago, Moog started out with a handful of people—about a dozen or so. Today, the company is still very modest, employing about three dozen people. The Synthesizers are built slowly with a great deal of care, and before each one goes out it is left on for a week and then dropped on the floor. "This procedure," a company representative told me, "helps to locate any construction flaws and insures that the instrument is rugged." Prices on Moog Synthesizers range from about \$3500 to \$8000 for a giant mother with all kinds of special features, but they won't sell you one unless you've had ample opportunity to play with one and fondle it. To find out how this might be best accomplished, you can write to them (R.A. Moog Co., Trumansburg, N. Y.), or go to Trumansburg yourself (phone ahead) and talk with them.

Basically, then, the Moog Synthesizer provides a very compact version of what is known as the classical electronic studio, which consists of various types of signal generators (frequency producers), modifiers, and mixers. Moog instruments employ a system known as voltage control in all of their operations. Voltage controlled instruments produce a voltage as a signal that may be controlled by other voltages from other instruments—and which varies in step with them, permitting rapid amplitude (loudness) and frequency change, making calculation and calibration a veritable snap.

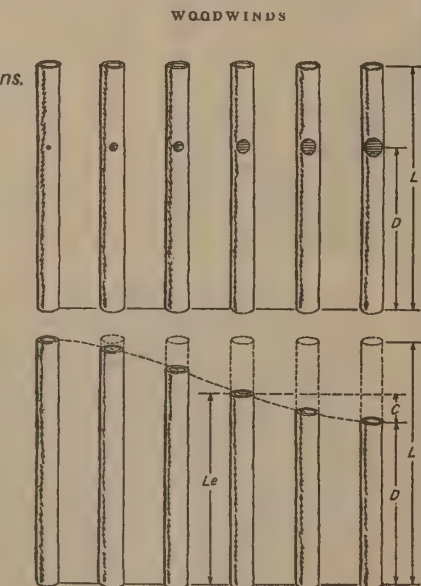

Fig. 46. The size of a side hole affects a pipe's vibrational frequencies. The extent of the effect is illustrated here by comparing different hole sizes with pipe lengths that give matching frequencies. Each pipe in the lower row has a frequency matching that of the holed pipe immediately above it.

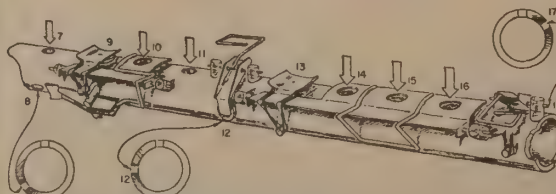

Fig. 66. Over-all layout of machinery for a Boehm-style flute. The large arrows show the finger and thumb holes, while the numbers refer to particular hole positions as explained in the text. The right-hand part of this diagram also applies to the clarinet.



★ The Rolling Stone

There's responsive media and non-responsive media. Non-responsive media (e.g. most newspapers, magazines, all TV, movies) bear a simple relation to the market: the users buy or don't buy the whole package; they have little influence on the piecemeal contents. Responsive media bear a complex relation to the market: users not only influence the whole package, they largely determine the contents by their actions in a market apart from the particular medium. One such responsive medium is the Wall Street Journal (see p. 66), which is sculptured by the behavior of the stock market.

Another such is Rolling Stone, which owes its existence and appeal to what's happening in the intensely competitive market of popular emergent music. Whose music is popular (or becoming popular) is the result of a zillion individual choices: "that's me, that's my music." The economy of the record industry squirts and flows and masses like weather. Rolling Stone nets into that whole dynamic, provides picture/text supplemental information on the strongest music sources, gives access information and some anticipation via reviews, and helps clarify the emergent terrain on which the emergent dancers are finding each other.

John and Paul can shoot looks at each other and exchange thoughts. John, full of Da Vinci-esque chutzpah and Lewis Carroll whimsy and Joycean logic, projects authority, sovereignty. Can you dig that Paul is his princess? Paul giggles. John smiles like Oedipus.

Paul is full of gestures, fluttering dissolves. The two of them rule benignly. George maintains the court. He is silently called upon to approve their musical approach to a song. And finally, the honorable Richard Starkey, a solid magnet, whose patiently churning guts hold the quartet inside the edges of possibility.

On a more obvious level, they express joy. Little jokes, banter, cracks in the heavy atmosphere. It must be hard to resist the temptation to take oneself seriously as a Beatle, but they do it every time. When they are not addressing each other personally, they referred to themselves not as We, but They.

"What do They do now?" (George.)  
 "Now They sing." (Paul.)

# ROLLING STONE

Rolling Stone  
 Jann Wenner, ed.  
 (bi-weekly)  
 \$6 /yr. U. S.  
 \$8 / yr. Canada  
 \$12/yr. overseas

from:  
 Subscription Department  
 Rolling Stone  
 746 Brannon Street  
 San Francisco, CA 94103

Just my luck: Paul McCartney, M.B.E. was standing there talking to four business-suited VIP's when I walked in. He was also in the mood to be interrupted by a strange lady with a film property.

I'd never seen him in person before. The impact was surprising. Diffused. Magical. Yes, he's very pretty. Yes, he's very charming. But who the hell is he? We talked small talk in that room, and I went away without script, totally Beatlized.

Definition of Beatlized: In an instant, you are aware of a confusing magnetism. You feel needed. Stoned. Flattered. Infatuated. Curious. You want to work there.



The Beatles? "I think it's impossible for them to do a tour. Mick has said it before, but it's worth repeating . . . the Beatles are primarily a recording group.

"Even though they drew the biggest crowds of their era in North America, I think the Beatles had passed their performing peak even before they were famous. They are a recording band, while our scene is the concerts and many of our records were roughly made, on purpose. Our sort of scene is to have a really good time with the audience.

"It's always been the Stones' thing to get up on stage and kick the crap out of everything. We had three years of that before we made it, and we were only just getting it together when we became famous. We still had plenty to do on stage and I think we still have. That's why the tour should be such a groove for us."

In a Silent Way, Miles Davis (Columbia CS 9875)

This is the kind of album that gives you faith in the future of music. It is not rock and roll, but it's nothing stereotyped as jazz either. All at once, it owes almost as much to the techniques developed by rock improvisors in the last four years as to Davis' jazz background. It is part of a transcendental new music which flushes categories away and, while using musical devices from all styles and cultures, is defined mainly by its deep emotion and unaffected originality.

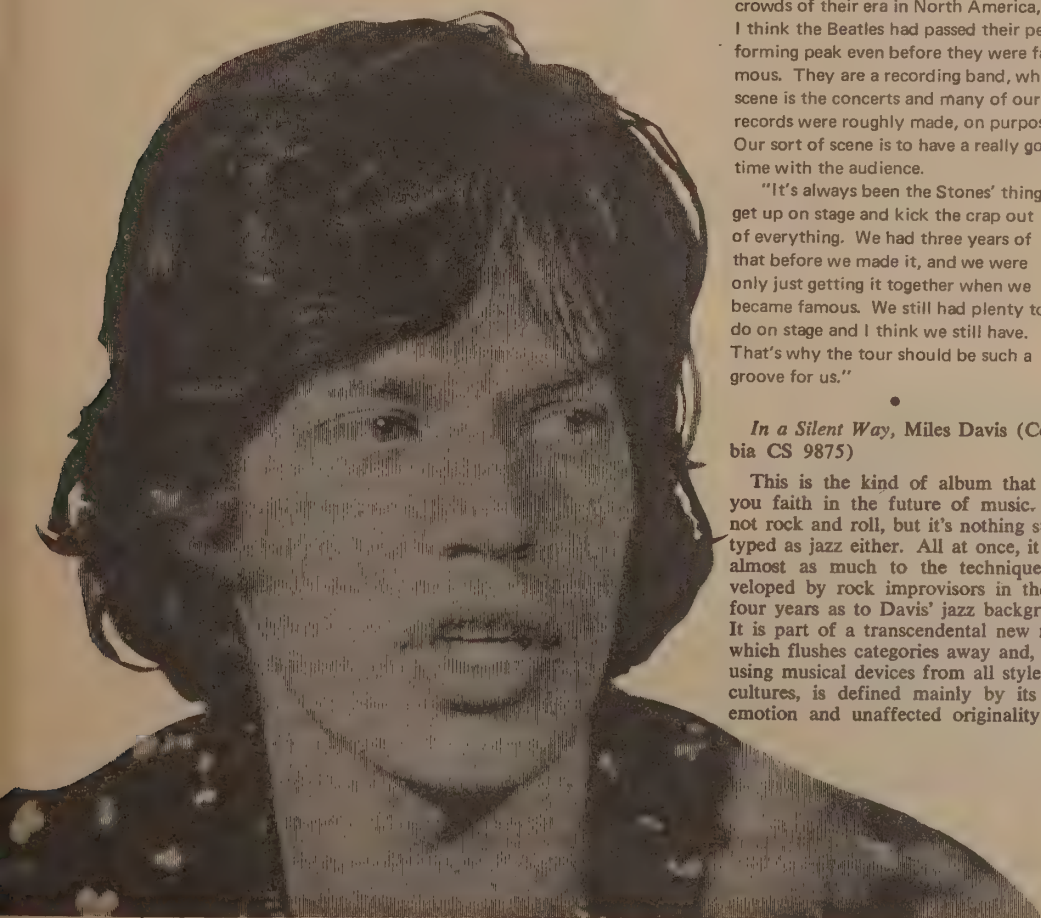

★ Improvising Jazz

An exceptionally clear explanation and analysis with original examples of the concepts basic to modern jazz composition and instrumental improvisation. But the title is deceptive. Modern jazz is 20th Century harmony superimposed on traditional types of chord progression, and this book should be of use to any student (or teacher) of musical practice.

The fundamental ideas of chord structure, notation, chord progression, modulation, and variation of motivic and thematic material, including a simplified chord symbolism, are presented in edible portions. The discussion of the more exotic concepts of chord/scale relationships, chord superimposition, and functional chord substitution, are among the best I have seen, including college texts. This book is a solid value that becomes more and more useful with every rereading.

[Suggested and reviewed by Peter Lynn Sessions]

Jazz has brought about a renaissance in improvisation, providing a style which is conducive to spontaneous creation by utilizing standard musical elements, such as 4/4 time, songs of uniform length and form (usually 32 measures in length, with an A-A-B-A structure), fairly standardized instrumentation, steady tempi, consistent and logical harmonies, stylized melodies and rhythms, and even an established order of introductions, statements of themes, sequence of soloists, and codas and endings. Such an established framework as we find in jazz improvisation is as useful to the jazz player as the twelve tone system is to the atonalist composer. The characteristics of the style make for swift decisions, enabling the music to move along without interruption.

What is the soloist doing when he attempts to "build"? Actually the ideal process hardly ever takes place—that is, it is hardly ever the case that a conscientious soloist plays a thinking solo for a hard-listening hearer—but when this does happen, the key process is memory. The soloist has to establish for the listener what the important POINT, the motif if you like, is, and then show as much as he can of what it is that he sees in that motif, extending the relationships of it to the basic while never giving the feeling he has forgotten it. In other words, I believe that it should be a basic principle to use repetition, rather than variety—but not too much. The listener is constantly making predictions; actual infinitesimal predictions as to whether the next event will be a repetition of something, or something different. The player is constantly either confirming or denying these predictions in the listener's mind. As nearly as we can tell (Kraehenbuehl at Yale and I), the listener must come out right about 50% of the time—if he is too successful in predicting, he will be bored; if he is too unsuccessful, he will give up and call the music "disorganized."

The tonic chords are like magnets, tugging at the other types of chords, giving the dominants and minor sevenths tension that must be resolved. The tonic is the only chord which offers complete rest. The dominants are so near to the tonic that they are intense and powerful, and must be resolved to the tonic. The minor sevenths, which function as subdominants, are remote from the tonic and act as a secondary tonic, offering repose, but not inertness. Therefore, subdominants lead to dominants, which move to tonics or back to subdominants. Once the progression reaches the tonic it usually ends or starts another cycle by moving out to a subdominant.

In further analyzing the blues, we find the tune to be twelve measures long, and in the key of C major. (For the present, let it suffice to say that we guess it to be in C major because it starts and ends on a C major seventh chord.) Since there is no given melody in Figure 1, we cannot determine the motivic construction; however, notice that the progression seems basically to contain four measures in C, then an implied feeling of F for two measures, followed by six measures of C chords and chords which are closely related to the key of C. These sections might be labeled A-B-A. We will discuss key modulations in a later section, when you have digested the terminology and information needed for such analysis. The term blues, in jazz, usually denotes a chord progression twelve bars in length, and also describes its mood.

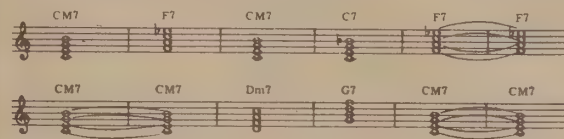

Ninth, eleventh, and thirteenth chords are produced by superimposing third intervals above the seventh chord, thereby adding color and a thicker texture to the seventh chord without changing its function. This practice is commonly used in jazz, because the extension of the seventh chord provides more harmonic choices.

Note that the ninth degree above the tonic corresponds to the second degree, except that it is written an octave higher; in like manner the eleventh and thirteenth correspond to a fourth (augmented fourth, in this instance) and sixth scale degree, respectively. These superimpositions have a certain potential for alterations, as do the third, fifth, and seventh of the seventh chords. It is up to you to remember which types of chords can use ninths, elevenths, and thirteenths, and which of these superimpositions can be altered in certain chords. The superimposition is considered unaltered if it is within the scale that accompanies the chord.



Improvising Jazz  
 Jerry Coker  
 1964; 115 pp.

\$1.95 postpaid

from:  
 Prentice-Hall, Inc.  
 Englewood Cliffs, N. J.  
 07632

**Allied Radio**

After considerable mail and discussion by CATALOG users, it seems clear that Allied is the best mail order source for electronic gear. They also print an industrial electronic catalog that is particularly rich in components, (especially noteworthy: integrated circuit components). Plug in, link up, incorporate.

Allied Electronics for Everyone

Allied Industrial Electronics Catalog

free

from: Allied Radio  
100 N. Western Avenue  
Chicago, Ill. 60680

[Reviewed by Larry Greisel.  
Suggested by Arthur Brand]

Other sources of electronics supplies include:

Lafayette Radio Electronics  
111 Jericho Turnpike  
Syosset, L.I., New York 11791

Catalog free. Much more imported equipment and components. We hear complaints about their service.

Olson Electronics  
260 South Forge Street  
Akron, Ohio 44308

Catalog, free, issued monthly. Olson tends toward imported and surplus items. Many small quantity, "special" items. Service was fair last time I ordered from them. Many stores throughout the U. S.

**Heathkit**

Eico kits feature better engineering, but use some old, 'surplus' parts. Heathkits always have fresh, recently manufactured parts; and the customer service (at least in 1958-60) gave patient, thorough advice and exchanged parts which the customer believed defective, with no questions asked. Best Heathkit buys are items designed by other manufacturers (e.g. the Magnecord tape deck; I own the 1960 model Heath-designed TR-1E tape deck and it's a lemon). On the other hand, Heath test instruments are thick in the test/quality control sections of precision-instrument manufacturers such as Tektronix, so the engineering must not be all bad (Heath copied the Tektronix panel for their oscilloscopes—cheap and fine, if not ethical, engineering).

**Heathkit Catalog**

1969; 115 pp. from:  
Schlumberger Products Corporation  
P. O. Box 167  
St. Joseph, Michigan 49085

**Famous Low-Cost "Benton Harbor Lunch Boxes" Compact 6 & 2 Meter Transceivers**

HW-29A

\$5750

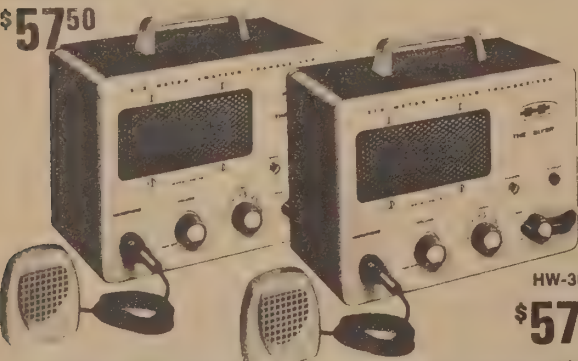

HW-30  
\$5750

• Perfect for the ham-on-the-go • Ideal for CAP, MARS, local net, or emergency operations • 5-watt input crystal-controlled A.M. transmitter • HW-30 2-meter model capable of operation on new USCG Auxiliary frequency 143.28 MHz

GO VHF FOR LESS . . . complete transceivers, lunch-box size. Feature crystal controlled transmitter with straight-through final amplifier. Crystals (not supplied) are in the 8 MHz range. Receiver is super-regenerative with RF stage . . . features 1 uv sensitivity! The built-in 120 VAC power supply, speaker, press-to-talk switch on front panel, and ceramic mike included make these units ready to go on the air with your antenna. Power cables for mobile and A.C. operation are included.

Kit HW-29A (6 meter), 9 lbs. . . . . \$57.50  
Kit HW-30 (2 meter), 9 lbs. . . . . \$57.50

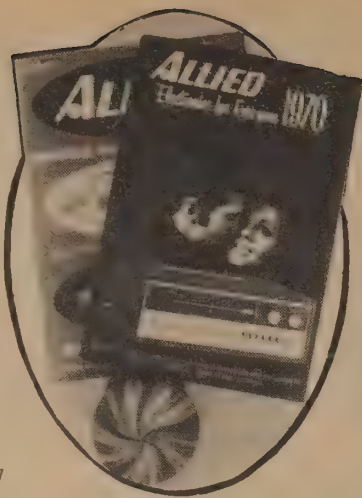

Allied Data Handbook is a handy little book useful to just about anyone fooling with electricity or electronics. Gobs of information for the Engineer as well as common man. \$1 postpaid from Allied, 112 pp.

Tables for tube substitution, nomographs for coil winding, nominal wire size charts, formulas of all electrical and electronic sorts, color codes.

I have had a copy around ever since I started tearing radios apart when I was 11 or 12. [Reviewed by Fred Richardson]



**Lightweight "Stereophones"**

Model K-6. Provide breathtaking full-dimensional sound. Accept up to 60 watts per channel from any normal music program source. Padded ear-band, vinyl-covered foam-filled ear-cushions. Lightweight (only 15 oz.)—listen for hours in complete comfort. Earcushions are removable for easy cleaning. Response, 10-15,000 Hz. 4-16 ohms. With 10-ft. cord, plug. 20 A 8358. Shpg. wt., 2 lbs. . . . . \$24.00

PS120 Nutdriver Set. Includes: 10 color-coded drivers from 1/16" to 3/8" in 1/16" steps. 3 1/2" drivers. Plastic case fits pocket. 26 A 2194. Wt., 11 oz. . . . . \$5.85



**MODEL 631 BATTERY-POWERED VTVM-VOM . . . TWO TESTERS IN ONE**

- One Selector Switch For Entire Unit
- Complete VOM in Combination With Battery-Operated VTVM
- 11-Megohm Input Impedance to VTVM

Single switch selector for VTVM or VOM operation. Has large, easy-to-read 5 1/2" meter with unbreakable face, and spring-backed jewels for ruggedness. Accuracy: VOM, ±3% DC, ±4% AC; VTVM, ±4%. VTVM, DC volts: 0-1.2-6-30-120 (11 megs input impedance). VOM, DC volts: 0-3-12-60-300-1200 (20,000 ohms/volt). AC and audio volts: 0-3-12-60-300-1200 (5000 ohms/volt). DC current: 0-60 µA; 0-1.2-12-1200 mA; 0-12 amps. dB: -20 to +63. Ohms: 0-1500-15K; 0-1.5-150 megs. Size, 7 1/2"x5 1/2"x3 1/2". Supplied complete with test leads, alligator clips, rubber feet, batteries and instructions. Shpg. wt., 5 lbs. 51 E 9113. . . . . \$78.00

Practice your guitar playing in private . . . only you can hear when you use this handy little unit. Or use two pairs of headphones so just you and your teacher can hear your playing. The all-transistor circuit is powered by a miniature 9 v. battery (not included) which will last up to 60 hours. This compact amplifier plugs directly into your guitar and will drive one or two pairs of stereo or monophonic headphones. Tone and volume may be varied by your guitar controls. The amplifier automatically turns on as you plug it into your guitar. Build it in one evening  
Kit TA-58, 2 lbs. . . . . \$11.95

**New Heathkit Guitar Headphone Amplifier For Private Practice and Instruction**

Kit TA-58  
\$11.95

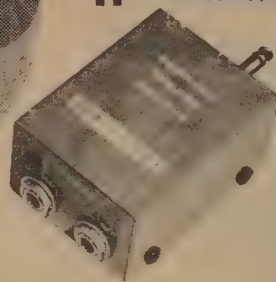

**XCELITE**

PS88 Screwdriver Set. 5 slot-tip types from 3/32" to 1/4"; 3 Phillips drivers, #0, #1, #2; 1x3 1/8" standard handle. 3 1/2" drivers. 26 A 2579. Wt., 11 oz. . . . . \$4.20

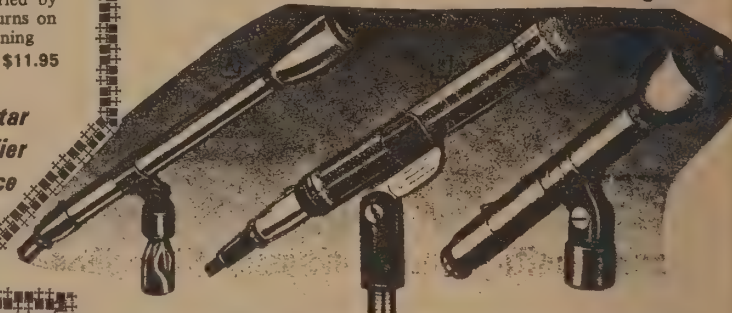

**Electro-Voice omnidirectional Mikes**

Model RE55 Professional Dynamic Mike. Omnidirectional response mike especially suited to full-range music recording and other exacting professional applications. For hand and stand use. Pop-proof; built-in blast filter. Response is extremely stable; mike can be calibrated for use as secondary lab standard. 40-20,000 Hz. 150 ohms. Output: -55 dB. 18' three-conductor cable. Satin nickel finish. 10 1/2"x1 1/2"x 3/4" shank. 12 A 7250. Wt., 1 1/4 lbs. . . . . \$126.00

Model 635A Performers' Dynamic Mike. Widely accepted professional omnidirectional mike for hand or stand use. Four-stage pop and blast filter eliminates need for external windscreen. Smooth, shaped response; 80-13,000 Hz. Low impedance. Output: -55 dB. Magnetically shielded diaphragm, turned-steel case. Cannon XLR-3-11 connectors. Non-reflecting nickel finish. 6x1 1/2" dia. 18' three-conductor cable. Stand adapter. 12 A 7481. Wt., 1 lb. . . . . \$49.20

**DRY REED SWITCHES**

Stock No.	Mfr's Type	Form	Size, Dia. x Lgth.	Max. DC Contact Watts	Max. Amps	Max. DC Volts	Actual Ing Magn	EACH
56 A 6603	MRR-2-185	A	.130x.800"	10	.5	200	H-33	1.15
56 A 6605	MRR-2-185	A	.090x.800"	10	.5	200	H-33	1.15
56 A 6606	MTRR-2-185	A	.092x.635"	3	.250	100	H-33	1.32
56 A 6607	MRG-DT-175	C	.130x.610"	3	.250	28	H-33	4.20
56 A 6608	MMRR-2-185	A	.090x.375"	1	.010	28	H-31	1.84
56 A 6609	DRG-2-425	A	.210x1.950"	15	1.0	400	H-34	.89
56 A 6610	DRR-1-425	A	.210x1.950"	15	1.0	250	H-34	.79
56 A 6611	DRT-5-425	A	.210x1.950"	50	3.0	1000	H-34	2.10
56 A 6612	SRR-2-425	A	.195x1.425"	15	1.0	400	H-32	.89
56 A 6613	DRG-DTH-445	C	.218x1.562"	10	.5	250	H-32	2.63
56 A 6614	DRVT-10-658	A	.218x1.950"	50	3.0	5000	H-34	4.20

**MERCURY-WETTED REED SWITCHES**

Stock No.	Mfr's Type	Form	Size, Dia. x Lgth.	Max. DC Contact Watts	Max. Amps	Max. DC Volts	Actual Ing Magn	EACH
56 A 6616	HRC-1-535	A	.218x1.950"	50	3.0	400	H-34	2.10
56 A 6617	MRC-3-387	A	.330x.710"	28	1.0	100	H-33	4.20

**MAGNETS FOR ABOVE SWITCHES**

Stock No.	Mfr's Type	D. x L.	EACH	Stock No.	Mfr's Type	D. x L.	EACH
56 A 6618	H-31	1/2"x1/2"x1/8"	.30	56 A 6620	H-33	1/2"x1/2"x1/8"	.30
56 A 6619	H-32	1/2"x1/2"x1/8"	.35	56 A 6621	H-34	1/2"x1/2"x1/8"	.40

**HAMLIN MAGNETIC REED SWITCHES**

- Hermetically Sealed
- Actuating Time—One ms or Less
- Life—10,000,000 Operations
- High Sensitivity
- Compact Size

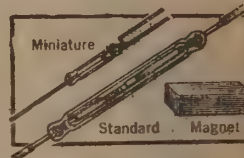

Premium-quality dry reed and mercury wetted switches for reliable operation under all operating conditions. They are hermetically sealed for safe, dependable use in any type of atmosphere or even under explosive conditions. Switches are unaffected by high or low temperature extremes or pressure.

Compact size, high sensitivity and rapid cycling rate make them ideal for applications in position indicators, counting instruments, limiting switches, flow meters, commutating instruments and relay relays. Fully inspected.

Actuating time of one millisecond or less. Dry reed switches have life expectancy of ten million operations; mercury wetted switches have life expectancy of one billion operations. All switches may be actuated by permanent or electro-magnets. Order optional permanent magnets from the table listed at left. Average shpg. wt. per switch, 1 oz.

DEFLEX GROUNDING PLUG. Lets you operate 3-wire appliances from 2 or 3-hole outlets without adapter. Button on plug deflects grounding blade for 2-hole outlets. Tension spring holds blade against metal faceplate. 26 A 3066. Wt., 3 oz. 79¢

**11 Tektronix Catalog**

11a Textronix has become the electronics industry standard for oscilloscopes. They are consistently ahead of the competition and their attention to "user" features in functions and control design make the instruments a joy to use. This catalog includes the complete line of scopes and of their other test equipment, particularly pulse generators and amplifiers, all solidly designed.

11b The equipment is expensive - \$735 for the cheapest scope - but well worth its price.

74

[Reviewed by Bill English.  
Suggested by Mike Brand]

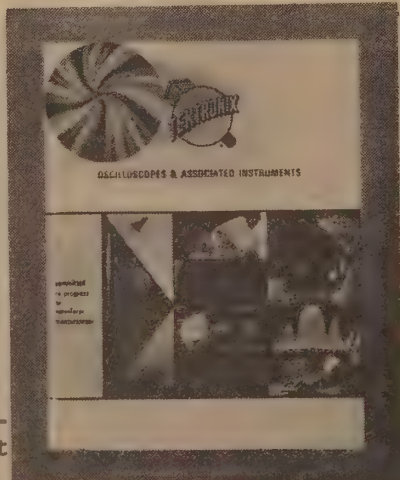

**3 The Radio Master**

3a A collection of advertizing material from manufacturers of electronic parts and equipment. It primarily covers components and test equipment and is a good reference to what is available. In many cases prices are not given and you may have to hunt for a local supplier of some items.

3b The Master is available from major distributors of parts and equipment, free if you are a good customer. [Bill English]

Tektronix Catalog  
1968; 336 pp.

free

from: Tektronix, Inc.  
P. O. Box 500  
Beaverton, Ore. 97005



TYPE 310A OSCILLOSCOPE . . \$725

**Bookmaking**

A textbook for book designers.

Should enable anyone from author to customer to communicate intelligently about any aspect of the design or production of a book. Probably the only existent reference for someone who needs to deal with printers and publishers, and isn't quite sure he knows an offset from a castoff. Perhaps the best thing that can be said about this book is that it is beautifully designed, but by the time you finish reading it you'll probably know enough to start criticizing its design.

**Bookmaking**

Marshall Lee  
1965; 399 pp.

**\$12.75** postpaid

from:  
R. R. Bowker Company  
1180 Avenue of the Americas  
New York, N. Y. 10036



To reconcile the sometimes divergent needs of the various aspects of bookmaking, decide first on what should be done creatively, then modify these decisions as necessary to accommodate the practical considerations. In other words, plan the ideal first and retain as much of it as you can. This works better than any other procedure because the creative process functions best when it is free of practical considerations. The moment you accept mechanical or economic limitations, your imagination tends to freeze. Not that it merely restricts itself to the practicable—it tends to act as though the limiting walls were made of glass, and it swings in a cramped arc far short of those walls. This is a safe enough procedure, but it precludes any chance of extending the possible.

Illustrations scattered through text

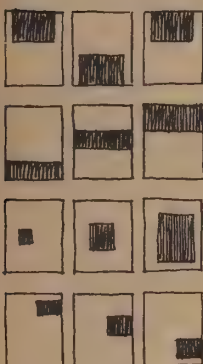

Four kinds of development in sequence.



Circular

*Electra Italic*  
[Oblique]  
*Electra Cursive*

*Janson Janson*  
*Baskerville Baskerville*  
*Caslon Caslon*  
*Granjon Granjon*

*Spartan*  
*Metro*  
*Erbar Light Condensed*  
*Optima*  
*News Gothic*  
*Vogue*  
*Gothic Condensed No. 2*  
GOTHIC NO. 31

*Memphis*  
*Cairo*

**PROOFREADERS' MARKS**

Marginal sign	Mark in text	Meaning	Corrected text
3	Proofreading	Delete, take out letter or word	Proofreading
(e)	Legibility is the requirement of a proofreader's marks.	Delete and close up	Legibility is the first requirement of a proofreader's marks.
first		Insert marginal addition	
( )		Close up entirely	
—	Symbols should be made neatly and	Less space	Symbols should be made neatly and
—		Push space down to avoid printing	
#	inline with the text to which they refer.	Add space	in line with the text to which they refer.
eg. #		Space evenly	
¶	Place marks carefully.	New paragraph	Place marks carefully. Paragraphs may be
no ¶	Paragraphs may be	No new paragraph	

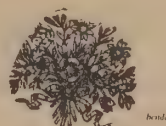

The readability of a page is affected by no less than 9 factors:

- (a) typeface,
- (b) size of type,
- (c) length of line,
- (d) leading,
- (e) page pattern (which includes "margins"),
- (f) contrast of type and paper (which includes color),
- (g) texture of paper,
- (h) typographic relationships (heads, folios, etc.), and
- (i) suitability to content.

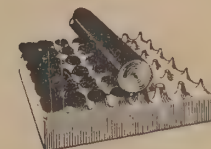
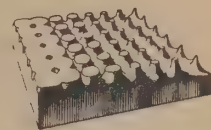

Color has 3 aspects: (a) hue, (b) intensity, and (c) value.

Hue—This is the 'color' of the color (red, blue, yellow, green, orange-red, etc.).

Intensity—This is the purity of the color (intensity is lowered as the color is grayed or 'softened').

Value—This is the darkness of the color (even in pure primary colors there is variation in value—yellow is lighter than blue, blue is lighter than red, etc.; however, an intense yellow may be darker than a blue whose intensity [and value] has been lowered by the addition of white).



There are many considerations involved in matching printer to job, but the main ones are:

- (a) the kind of presses he has (letterpress, offset lithography, gravure),
- (b) the size presses he has,
- (c) the number of presses he has (this relates to capacity to produce),
- (d) the kind of work he has done,
- (e) the quality of his work,
- (f) his schedule, and
- (g) his prices.

**Blackwell's Books, England**

Blackwell's Bookstore in Oxford, England, is a service which the Catalog should list. Their collection is probably the world's most comprehensive and they run a global service, providing lengthy, free, separate catalogs on about 25 subject areas, including children's books, books in other languages, science, literature, philosophy, religion, mathematics, etc. Their prices are significantly lower and they will not send a book which can be obtained more cheaply in America unless you so request. They will open an account for you, accept your personal check, and bill you semi-annually. They also buy up old libraries (occasionally famous ones, recently John Masefield's) and issue catalogs on second-hand books and first editions. They have a cable code OXFAM and a code system which enables you to place an order with a minimum of cost in a hurry. The books arrive slowly but the catalogs keep coming in all year long and are a great delight themselves.

[Suggested and reviewed by Larry Schwartz]

Catalog

free

from: **BLACKWELL'S**  
Broad Street, Oxford, England

**Internews**

Interesting service. For \$12.00 a year you get local English language newspapers from Ireland, England, Scotland, France, Canada, Mexico, Panama, Brazil, Ghana, South Africa, Israel, Spain, Mallorca, Italy, Japan, Hong Kong, India, Bahama, Australia, New Zealand, Isle of Man, Greece, Venezuela, and Holland.

[Suggested by Patrick Leavens]

Internews

**\$12.00/yr.**

from:  
Internews Co.  
P. O. Box 3138  
Aspen, Colo. 81611

**American Booksellers Association**

If you're thinking about retailing books, there's a service you should know about. For \$25 (first-year rate) you can join The American Booksellers Association (ABA) and get two very useful things. 1) The Book Buyer's Handbook, which lists all the publishers and all the necessary trade information—addresses, discounts, credit terms, returns policies, officers, etc. 2) Single Copy Order Forms, which facilitate orders for single books and get approximately the same discount you would expect for an order of five books. Among other things, the form makes it possible to have a book sent straight from the publisher to the customer.

[Suggested by The Checkered Frog]

American Booksellers Association, Inc.  
175 Fifth Avenue  
New York, N. Y. 10010

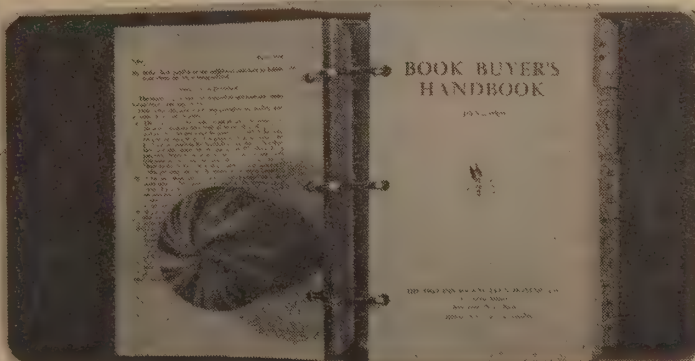

**Wittenborn and Co.**

When it comes to buying books by mail I've had few times when it's been really necessary. Mostly they've been when I've been away from New York and I wanted the book NOW. If the book involved the visual arts and came from anywhere in the world, I've sent the price or its approximation to Wittenborn and presto! They have always responded immediately and more than satisfactorily. They're the kind of book store that has most of the staff mailing or typing—busy—not getting in your hair if you want to browse but always helpful. We've never been able to think of a book they haven't been able to help us with; they are always ready to refer you to someone else if they can't help out. They have always been a regular stop for information re-charge with us. Introducing new customers is always a charge: they get kind of watery knees as they begin browsing and suddenly bank accounts fail.

Wittenborn publishes free lists of recent arrivals on their shelves; they are mailed irregularly. They give a 10% "courtesy discount" with some arm twisting. They are the best source in the U. S. for back issues of art and architecture magazines from both the U. S. and most everywhere else. They also publish and/or distribute many small publications such as Ed Ruscha's Royal Road Test and large publications such as Tantra Art. In short, it's a book freak's heaven.

[Suggested and reviewed by ONYX]

Catalog

free

from:  
Wittenborn and Co.  
1018 Madison Avenue  
New York, N. Y. 10021

"Of Theatrical Materials Services & Information." Where to find play leases, actors' agents, costumes, make-up, scenery, curtains, projection systems, lighting, props, sound equipment, signs, photographers, books, periodicals, foundations, and so forth. Covers U. S. and Canada.

[Suggested by Bob Shelli]



**THEATRICAL MAKE-UP**  
Complete Assortment  
Catalog on Request  
Mail Orders Filled  
**ZAUDER BROS., INC.**  
75 W. 45 St. NYC 36  
PL 7-2155

**CHLOE'S COSTUMES**  
CREATORS AND SUPPLIERS  
— WHOLESALE AND RETAIL — OF  
**PAPIER-MACHE HEADS AND MASKS**  
Made to Order —  
For Rent or Sale  
We rent and sell COSTUMES, accessories and wigs. Illus. CATALOG!  
41 Hempstead Turnpike  
Farmingdale, N.Y. 11735  
Tel. (516) MY 4-0599



- THEATRE BUILDING**
- 537. **ACOUSTICS.** By Leo L. Beranek. \$13.75
  - 530. **CONTEMPORARY THEATRE ARCHITECTURE.** A survey illus w. photos, plans, cross-sections of some outstanding recently built theatres & auds. By Maxwell Silverman. \$10.00
  - 540. **ENCYCLOPEDIA GUIDE TO PLANNING & ESTABLISHING AN AUDITORIUM, ARENA, COLISEUM OR MULTI-PURPOSE BUILDING.** By Herman J. Penn. \$45.00
  - 526. **IDEAL THEATRE, THE.** Eight designers present their concepts of theatres to serve varying functions. P \$2.00
  - PLANNING FOR THE THEATRE.** By Ned A. Bowman, Dept. of Speech/Theatre Arts, Carnegie Tech, Pittsburgh.
  - RECENT PUBLICATIONS ON THEATRE ARCHITECTURE.** Compiled by Ned A. Bowman & Glorienne Engel. Amer. Educa. Th. Assn., Wash, D.C. P \$1.50

**The Stanislavsky Heritage**

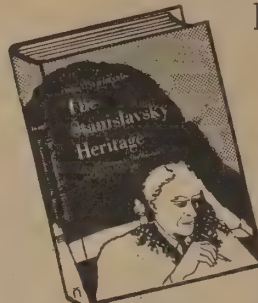

Its Contribution to the Russian and American Theatre. By Christine Edwards, foreword by Robert Lewis.  
Clears away many current misconceptions about "The Method," provides a comprehensive discussion of the meaning of Stanislavsky's System for the American theatre, clarifying the influence of the 'System' on contemporary concepts of acting and staging. New York Univ. Press. Cloth \$10. Paper \$3.50.

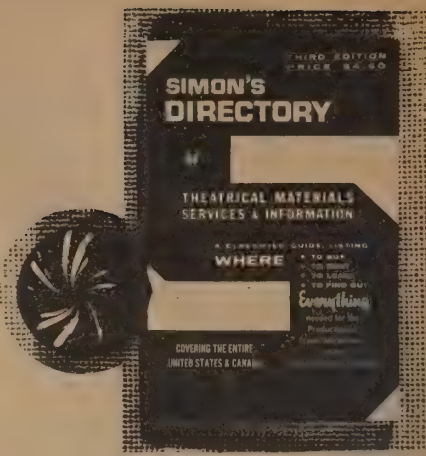

**Simon's Directory of Theatrical Materials Services & Information**  
1966; 240 pp.  
\$4.60 postpaid  
from:  
Package Publicity Service  
1564 Broadway  
New York, N. Y. 10036

**Subject Guide to Books in Print**

We use it; maybe you can. In one fat book are all the titles in print, along with cost and publisher, listed by subject category. Addresses of publishers are given in the front of the book. Outside of a library, there's no better way to find out what's available in a particular area. If you're trying to stay current in your field, the bi-monthly Subject Guide to Forthcoming Books may be preferable.



**Subject Guide to Books in Print**  
Annually in the Fall; 2724 pp. (1967)  
\$18.25 postpaid

**Crafts**

- Adventures in Scrap Craft. Dank, M. Dec 9, 1968. pap. 1.75. Dover
- American Art & Crafts Movement. Freeman, J. C. Oct 15, 1968. pap. 1.95. Century House
- America's Knitting Book. Taylor, G. Nov 25, 1968. 9.95 Scribner.
- Art of Blacksmithing. Bealer, A. W. Mar, 1969. 7.95. Funk & W.
- Art of Papier-Mache. Kuykendall, K. Oct. 1968. 8.95. Hearthside.
- Art of the Oriental Rug. Aanavi, D. Nov, 1968. 17.50. Corinthian.
- Basic Crafts. Lindbeck, J. et al (Eli). Oct. 1968. price not set; prepub. 5.96. BennettCo.
- Blanc De Chine: The Porcelain of Tehua in Fukien.
- Book of Rookwood Pottery. Peck, H. Oct 31, 1968. 7.50. Crown.
- Bronzes of West Africa. Underwood, L. Nov 15, 1968. 3.50. Transatlantic.
- Buffalo Pottery. Altman, S. & V. Feb, 1969. 10.00. Crown.
- Buttons. Epstein, D. Oct 23, 1968. 3.50. Walker Weath.
- Chess Sets. Graham, F. L. Oct 23, 1968. 3.50. Walker Weath.

**Art Prints**

Since 1949 UNESCO has been trying to update and internationalize the world of Art Prints. They have a central archives of prints, and a committee of experts who decide which prints to include in their catalogs. The criteria are: quality of print, significance of the painter, and importance of the painting.

There are two UNESCO print catalogs: Catalogue of Colour Reproductions of Paintings Prior to 1860 and the same of paintings from 1860 to 1965. Both are understandably limited in scope by what quality prints are available, and the choice of painters and paintings is often poor. Too much trivial or repetitive work by minor painters takes the place of better paintings by major artists. The catalog does function as a useful access device, and includes reproductions of many inspired paintings, not all of which are expensive. Each entry includes the artist's name, dates, a black & white photo of the painting, its title, date, medium, size and collection in which it rests. In addition, there are lists of publishers and printers, and information on purchasing prints.

Catalogs are trilingual in French/English/Spanish and print dimensions are given in both inches and centimeters. But price conversions are not given so you must deal with each foreign price. - [Reviewed by Joe Bonner & Annie Helmuth]

If you want good prints of Giorgione, Van der Weyden, Klee etc., see the Unesco catalogs at your library or:

**Catalogue of Colour Reproductions of Paintings Prior to 1860**  
1968; 451 pp.  
\$8.50 postpaid

**Catalogue of Colour Reproductions of Paintings 1860-1965**  
1966; 561 pp.  
\$7.00 postpaid

both from:  
International Publications Service  
303 Park Avenue South  
New York, N. Y. 10010

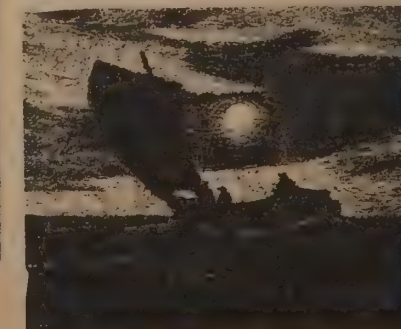
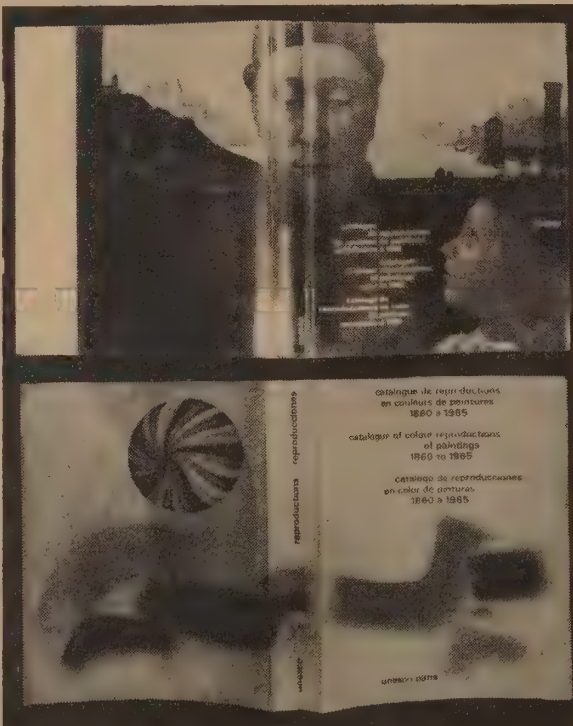
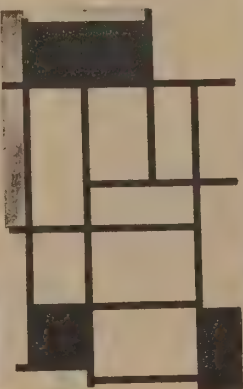

# Previously listed in Communications and still beloved:

## The Mind of the Dolphin

Lilly knows that it is to everybody's advantage for one kind of computer to link up with another, and that's his program with dolphins. This book reports his speculations and experiments with dolphins in recent years. Included is a thorough account by a girl, Margaret Howe, who lived alone with Peter Dolphin for 10 weeks. As usual with research on communication, everything discovered has broad implications.

Sometimes I feel that if man could become more involved in some problems of an alien species, he may become less involved with his own egocentric pursuits, and deadly competition within his species, and become somehow a better being.

**The Mind of the Dolphin**  
John Cunningham Lilly, M. D.  
1967; 286 pp.

from:  
Avon Books  
250 West 55th Street  
New York, N. Y. 10019

\$1.95 postpaid

or WHOLE EARTH CATALOG

## A Model of the Brain

Inside every brain there is a model of the world. How does all the elaborate wiring help us, or any other creature, make our model of the world? A noted British anatomist, J. Z. (Jay Zed) Young has spent many pleasant summers in Naples studying the behavior of octopuses, and has also done a great deal of work on the anatomy of their nervous system. The result is a fascinating picture of how to teach octopuses to do things, and some interesting—though not yet very deep—speculation on how cybernetics might help us to relate brain structure to external behavior. Especially interesting are the many hypotheses about the building of networks which can learn. At this early stage all such models are wrong, but we learn from our mistakes. One approach to all this is mental introspection. Here, on the other hand, we learn what we can learn about learning by literally introspecting: looking inside the head of an octopus to see what networks there could possibly change as the animal learns.

[Reviewed by Michael Arbib.  
Suggested by David Evans]

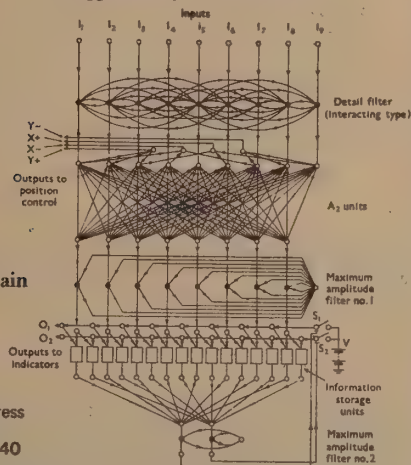

**A Model of the Brain**  
J. Z. Young  
1964; 348 pp.

\$8.50 postpaid

from:  
Oxford University Press  
16-00 Pollitt Drive  
Fair Lawn, N. J. 07140

or WHOLE EARTH CATALOG

FIG. 107. Signal flow diagram of experimental automatic pattern-recognition apparatus. The inputs to the nine detail filter terminals are supplied by photoelectric multipliers arranged in a 3x3 matrix. Patterns are centered automatically by combining outputs of the detail filters to form position controls. The filtered inputs are then connected to eight 'A2' units, one of these will show a maximum amplitude for each pattern (Fig. 108) and this is selected by the first maximum amplitude filter. The outputs of these supply eight pulse generators and these in turn sixteen capacitor storage units. During the teaching process the switches S1 and S2 are closed manually or by means of some artificial external classification system. After learning the switches are closed by electromagnets supplied by the outputs of maximum amplitude filter 2. In both cases the closed switch applied the voltage V to one of the output terminals O1 or O2. The same voltage is also connected to an input of the information-storage unit. (After Taylor, 1959.)

## Data Study

Information that isn't organized isn't signal in your life, it's noise. You waste yourself searching the full length of a file for something, feeling as stupid as a driver in crosstown New York, and for the same reason: your access is brute linear and laborious. This book can help you if not New York. It presents theory and practice on how to keep stuff straight, at least in terms of organization. Display is another matter, however, in which the information sciences are still poor.

**Data Study**  
J. L. Jolley  
1968; 254 pp.

\$2.45 postpaid

from:  
McGraw-Hill Book Company  
Princeton Road  
Hightstown, N. J. 08520

Manchester Road  
Manchester, Missouri 63062  
8171 Redwood Highway  
Novato, CA 94947

or WHOLE EARTH CATALOG

## McBee Keysort System

What do you have a lot of? Students, subscribers, notes, books, records, clients, projects? Once you're past 50 or 100 of whatever, it's tough to keep track, time to externalize your store and retrieve system. One handy method this side of a high-rent computer is McBee. It's funky and functional: cards with a lot of holes in the edges, a long blunt needle, and a notch. Run the needle through a hole in a bunch of cards, lift, and the cards notched in that hole don't rise; they fall out. So you don't have to keep the cards in order. You can sort them by feature, number, alphabetically or whatever: just poke, fan, lift and catch. In addition the cards have a feature which will print an address (or whatever) per card with two swipes of a hand-held strong-smelling gizmo—about 50 good copies before the print returns to primordial fuzz. Doug Engelbart tells us that animal ear notchers are better and cheaper for card notching than the nippers McBee sells.

[Suggested by Doug Engelbart and Joe Bonner]

Costs go like this:

- 1000 (print-type) keysort cards — 35.75
- 1000 Hecto carbon black (for printing) — 3.60
- 1 Keysorter (needle) — 5.05
- 1 Handpunch — 9.55
- 1 Handprinter (gizmo) — 41.40

Check your phonebook for McBee or write  
Litton Automated Business Systems  
Route 50 East  
Athens, Ohio 45701



## Music by Computers

Music by Computers. Goddamn right. When can we get our hands on them without having to tiptoe around some 18th century Department Chairman? This book and four records edited by the worthy Von Foerster and others assembles James W. Beauchamp, Herbert Brun, M. David Freedman, Lejaren Hiller, M. V. Mathews, J. R. Pierce, J. K. Randall, Arthur Roberts, L. Rosler and Gerald Strang. What I want to know is, can Frank Zappa use it?

**Music by Computers**  
Heinz von Foerster and  
James W. Beauchamp, ed.  
1969; 139 pp., 4 records

\$14.95 postpaid

from:  
John Wiley & Sons, Inc.  
One Wiley Drive  
Somerset, N. J. 08873  
West:  
1530 South Redwood Road  
Salt Lake City, Utah 84104

or WHOLE EARTH CATALOG

## Colour Guitar

If you've ever wanted to play a guitar without memorizing all the chords first, then get Colour Guitar, stick the colour tone location labels (paired with the 12 notes of the major scale) on the fingerboard and go to it. For example, a yellow tone location label shows you where to fret a string to make an F tone; a combination of "sunset-colours" for an F major chord. Besides the colour labels, Colour Guitar includes a colour key to patterns; pictures, charts and positioning diagrams; the colour matrix board (to be used with punched overlay charts for fingering patterns); exercises, and an explanation of the musical theory and playing techniques you will be exploring.

Once you recognize the patterns your fingers make as they move up and down the fingerboard you're playing with a tone-model of universal relationships that are repeated everywhere in some form—from waves of sound to whitecaps in the ocean.

[Reviewed by Annie Helmuth]



**Colour Guitar**  
Dave Guard  
1967; 23 pp.; illus.

\$15.00 postpaid

from:  
Britannia Enterprises, Ltd.  
c/o Brobeck, Phleger & Harrison  
111 Sutter Street  
San Francisco, CA 94104

or WHOLE EARTH CATALOG

## The Radio Amateur's Handbook

### 10 The Radio Amateur's Handbook

10a This has been the practical guide for radio amateurs for 43 years. It begins with the fundamentals of electric circuits and follows a simple development of the radio theory necessary to understand communications. There is brief section on laws governing amateurs and references to other books that are valuable aids in obtaining a license.

10b Throughout the book actual circuits are shown, always with enough information to build them. Later sections cover complete construction details for various transmitters and receivers but don't be misled by their apparent simplicity. It takes a lot of time and know-how to make these things work and unless circuit building is your thing you are better off to buy commercial equipment or kits. (Heathkit is one of the best sources for ham gear.)

[Reviewed by Bill English.  
Suggested by Arthur Brand]

The above review was prepared and printed on a computer by Bill English—as you can see, the fluidity of computer interaction makes spelling more casual than with direct hard print.

The Radio Amateur's Handbook may be of interest to the communities and enclaves who've been fantasizing an underground radio net. Like a night of the week or month when all the world's long-hairs are on the air, vibing to each other and the stars.

### The Radio Amateur's Handbook

American Radio Relay League  
1925... 1969; 611 pp.

\$4.00 postpaid

\$4.50 Canada, \$5.50 elsewhere

from:  
The American Radio Relay League  
Newington, Conn. 06111

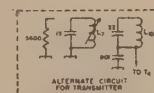
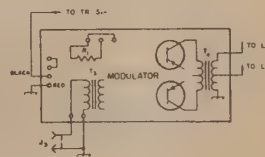

## Printing as a Hobby

Most books that deal with printing are of a highly technical nature; aimed at the professional printer, or someone aspiring to be one. This book, on the other hand, is aimed specifically at the beginner with very little money. With this book and \$10 you can set up your own private print shop. And if you want to graduate later to a small printing press, Mr. Lieberman explains the processes involved with that also.

[Suggested and reviewed  
by Lloyd Martin]

**Printing as a Hobby**  
J. Ben Lieberman  
1963; 128 pp.

\$1.95 postpaid

from:  
Signet-New American Library  
1301 Avenue of the Americas  
New York, N. Y. 10019

or WHOLE EARTH CATALOG

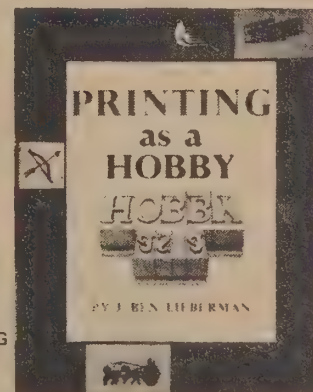

# Community

## Foods by Mail

Sources for foods that are not treated with DDT, fumigants, etc. Most of these outfits are family affairs, and dedicated to supplying customers with real foods, mostly by mail.

### Wheat

Deaf Smith County, Texas is a mineral-rich area that produces wheat with high amounts of protein—the best wheat available. 50 lbs: \$7.00 plus postage.

From:  
Vitamin Products Company  
2401 South Atlantic Blvd.  
City of Commerce, CA 90022  
or  
Lee Foundation  
2023 W. Wisconsin Ave.  
Milwaukee, Wisc. 53233

### The Food Mill

Large stocks of bulk foods.  
Gallons of avocado honey,  
fresh peanut butter.

Leaflet from:  
The Food Mill  
3033 MacArthur Blvd.  
Oakland, CA

★  
Erewhon Trading Company

New England source of  
natural foods.

Brochure from:  
Erewhon Trading Company, Inc.  
342 Newbury Street  
Boston, Mass. 02115

### List of 325 Natural Food Sources

Organic Gardening Magazine has compiled a list of organic food suppliers throughout the U. S. Includes fresh and frozen vegetables, fruits, grains, etc. For 1969-70.

**\$1.00** postpaid

from:  
Shopping Guide  
Rodale Press  
Emmaus, PA 18049

### Rice

Best short-grain brown rice grown in U.S. (although not organic according to Fred Rohe) is available at the mill, about \$12 for 100 lbs. No mail orders.

Koda Brothers  
Russell Road  
Dos Palos, CA

### New Age Natural Foods

Headed by Fred Rohe, this is now San Francisco's largest natural food store. Their first mail order catalog is now available.

Catalog from:  
New Age Natural Foods  
1326 Ninth Avenue  
San Francisco, CA 94122



### ★ Perma-Pak

The best source we've seen for storeable foods is this outfit in Utah which caters to keep-a-year's supply Mormons. The prices look remarkably good on a wide range of stuff from brown rice (\$14.95/100 lbs) to crispy chips of spun vegetable protein (\$44.95/25 lbs). They have a "Year's Food Supply" deal for \$129.95 (360 lbs). We're carrying two of their smaller food kits (below) to show what it's like.

[Suggested by Gary Snyder]

### Jaffe Brothers

Oils, dried fruits, nuts, seeds, grains.

Brochure from:  
Jaffe Brothers  
28560 Lilac Road  
Valley Center, CA 92802



### Walnut Acres

Best, most reputable source in U.S. Foods like you've never tasted: unrefined corn germ oil, 40 lb. tubs of peanut butter, krinkled rye cereal. If you order with friends, bulk orders are economical.

Brochure from:  
Walnut Acres Mill & Store  
Penns Creek, Penna. 17862

### Catalog free

from:  
Perma-Pak  
40 East 2430 South  
Salt Lake City, Utah 84115

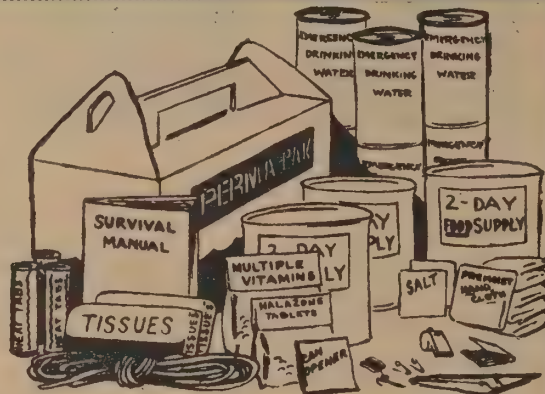

Food for one for 6 days. No cooking. Freezing does not harm. Emergency survival kit including yukon biscuits, tropical chocolate, energy tablets, permican, halazone, vitamins, canned water, heat tabs, nylon rope, whistle, fish hooks, etc.

**Karry-Kit \$8.50**, wt. 12 lbs

from Perma-Pak or WHOLE EARTH CATALOG

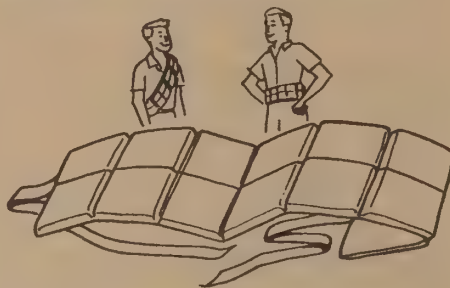

3 days of balanced rations. No cooking. Ties around waist or over shoulder. Add water to prepare.

**Chow Belt \$3.50**, wt. 2 lbs

from Perma-Pak or WHOLE EARTH CATALOG

### Lee Electric Flour Mills

The best bread is made from wheat ground just before baking.

This is a small electric grain grinder manufactured by an old dependable company. A unique feature of this machine is that it grinds the entire grain kernel, including the germ and bran, into fine flour. (Other mills generally discard the germ). You fill the hopper and an automatic feed admits the proper amount of grain into the stone grinding chamber. The carborundum grinding stone never needs redressing, the mill does not get warm enough to impair the nutritional value of the flour, and fresh stone ground flour...pass the bread!

[Suggested and reviewed by Lloyd Kahn]

### Catalog free

from:  
Lee Engineering Co.  
2023 West Wisconsin Ave.  
Milwaukee, Wisc. 53201



MODEL	MOTOR SIZE	OUTPUT PER HOUR		PRICE
		FINE FLOUR	COARSE MEAL	
500	1/6 H.P.	3 TO 5 LBS.	NOT ADJUSTABLE	\$95.00
600	1/6 H.P.	3 TO 5 LBS.	20 TO 25 LBS.	\$125.00
S-500	1/4 H.P.	6 TO 10 LBS.	NOT ADJUSTABLE	\$145.00
S-600	1/4 H.P.	6 TO 10 LBS.	40 TO 45 LBS.	\$170.00

Operating Voltage\* 115 AC-DC  
Current Draw 3.0 amperes  
Overall Height 20 inches  
Shipping Weight 20 pounds

### Corona Hand Mill

From all we can gather, this is the best of the hand mills for grains, etc. With two grindings you get not bad flour.

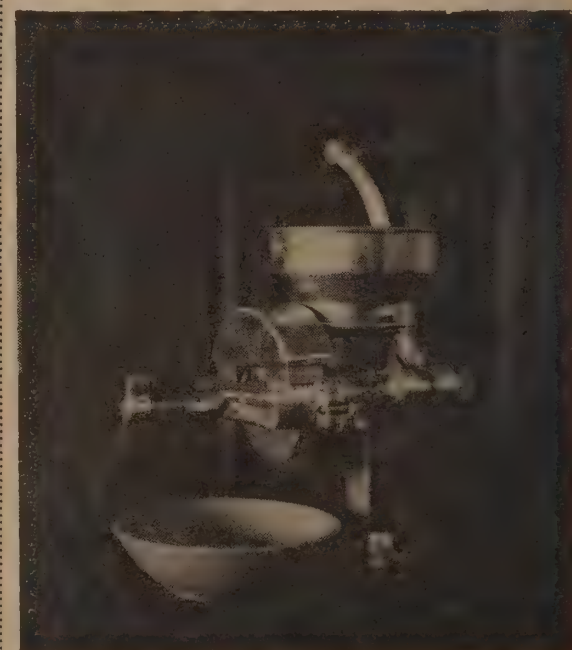

### Corona Hand Mill

**\$12.75** postpaid (**\$10.00** in the store)

from:  
WHOLE EARTH CATALOG  
558 Santa Cruz Avenue  
Menlo Park, CA 94025

**★ Joy of Cooking**

Adele Davis and Ohsawa to the contrary, I'm of the school that dietary schemes are out-front paranoia. A healthy mind insures a healthy body & vice versa; and what's needed more than special diets are common sense and good cooking. No food badly prepared is good for you. If you simply insure that all you eat is fresh, unpoisoned, and well prepared, the vitamins and proteins will take care of themselves. Rombauer's Joy of Cooking is the American bible of food & is essential in any household where food is enjoyed. Not only are her recipes enjoyable, but she goes into the basic structure of food & food preparation techniques that give the novice a good idea of what's happening in the kitchen.

[Reviewed by Johan Mathiesen.  
Suggested by Charlotte A. Wolter.]

Certain vegetables and fruits should not be stored together. Apples give off an ethylene gas that makes carrots bitter, for example, and onions hasten the spoilage of potatoes. Watch for other such relationships. Do not wash vegetables until you are ready to use them and then do not soak them, except as indicated, because moisture tends to leach away the water-soluble vitamins.

If you are willing to cut down on refined starch and sugar items, especially fancy baked goods, bottled drinks and candies, a higher percentage of the diet dollar will be released for dairy products, vegetables and fruits. Do not buy more perishable foods than you can properly store. Use leftovers cold, preferably. To reheat them with minimal loss, see page 139.

A new therapy for the treatment of small burns about the hands is to plunge the burned area into cold water.

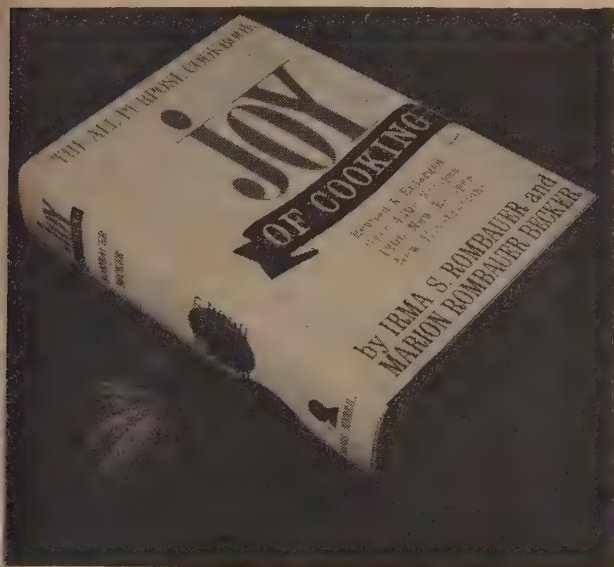

**Joy of Cooking**  
Irma S. Rombauer,  
Marion Rombauer Becker  
1931 . . . 1967; 849 pp.

**\$6.95** postpaid

from:  
Bobbs-Merrill Co., Inc.  
4300 West 62nd Street  
Indianapolis, Ind. 46206

or **WHOLE EARTH CATALOG**

Climate and age also change protein requirements. The colder the climate the greater the need. And no matter what the climate, growing children, pregnant women and nursing mothers need a larger proportion of protein than the average adult.

Cooking in mountainous country is an art all in itself. If high altitudes are new to you, watch for the high altitude cooking symbol which will give you formulas for adjusted ingredients or temperatures.

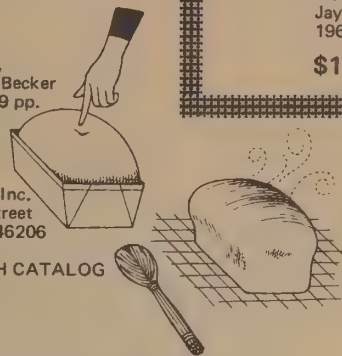

**★ The Impoverished Students' Book of Cookery, Drinkery, & Housekeeping**

A brief intelligent introduction to cheap food preparation.

[Suggested by Derek Shearer]

**What to Do with Left-Over Bread**

Never throw out any dry, left-over bread. Slice it, dip it in a mixture of egg-milk-sugar-vanilla-and a dash-of-salt, fry it in butter and you have French Toast. Cube it, sprinkle with melted butter and garlic salt, brown it under the broiler, and you have Croutons. Roll or grind it into crumbs, put them in a plastic bag, and refrigerate, and you'll never have to buy bread-crumbs. Or just use it dry as a doorstop.

**The Impoverished Students' Book of Cookery, Drinkery and Housekeeping**  
Jay F. Rosenberg  
1965; 48 pp.

**\$1.25** postpaid

from:  
Doubleday & Co.  
501 Franklin Avenue  
Garden City, Long Island, NY 11531

or **WHOLE EARTH CATALOG**

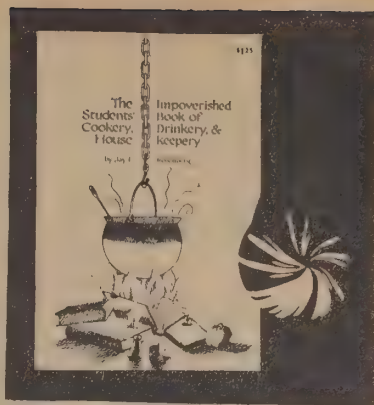

**Zen Macrobiotic Cooking**

A good place to start with Macrobiotics (the philosophy of eating as a means to vitality and rejuvenation).

This book is more recent, pleasantly readable, liberal and digestible than the writings of the system's founder-master Georges Ohsawa. However, once you read this, you may get into the others. Also a monthly publication.

[Reviewed by Lloyd Kahn]

In Japan it is known as yin and yang. Here, in America, it goes by the rather chemical terms of acidity and alkalinity. For instance, you eat something acid and have heartburn; common knowledge tells you to take something alkaline, Alka-Seltzer, perhaps. Acid foods are rich in potassium; alkaline, in sodium.

**A few do's and don'ts**

Learn above all to cook rice and to cook it well. One condition is to use a heavy cast-iron pot. Prior to cooking, wash the rice with cold water in a strainer. While cooking, never stir the rice, and keep it covered.

Sometimes when you cook rice, the bottom of the pot is slightly scorched. This part is yang. It is very rich in minerals and very good for yin people.

**Zen Macrobiotic Cooking Book of Oriental and Traditional Recipes**  
Michael Abehsera  
1968; 205 pp.

**\$6.25** postpaid

from:  
The Order of the Universe  
Publications  
Box 203, Prudential  
Center Station  
Boston, Mass. 02199

or **WHOLE EARTH CATALOG**

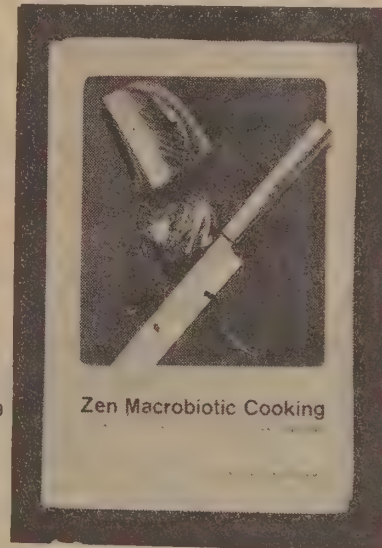

**Ball Blue Book**

Though this guide to home canning has been in print since 1909, it easily avoids the Grandma image and gets you into your own canning. It has illustrated, step-by-step directions and recipes and handy guides for jar estimating. When something goes wrong, there's trouble-shooting guides. If you have a good growing summer, this book can help you have a well-fed winter. A buy.

**Ball Blue Book**  
1966; 100 pp.

**\$3.35** postpaid

from:  
Ball Bros. Co., Inc.  
Muncie, Indiana

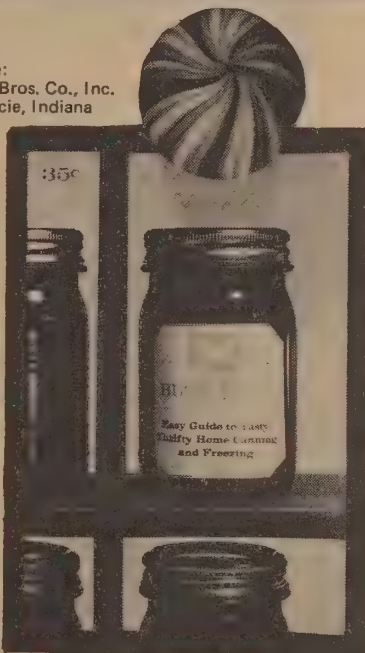

**★ Quantity Recipes**

In a commune I lived in in New Mexico we had two major problems: food and sex. This book will go a long way to helping you solve the first. What a drag to take down the Joy of Cooking, find something really groovy to fix for yourself and friends and have to spend a half an hour multiplying all the ingredients by seven or eight knowing that you couldn't possibly need a cup of oregano in the chile, but that's what your figures say. We ate some pretty bad experiments and several of the women and men shied away forever from anything but the lettuce salads. Enormous pots of food take a certain skill or they become enormous pots of glop.

This book starts off with the assumption that you need advice on measurement adjustment and conversion, that you don't know anything about quantity size utensils, that you never fixed fifty servings of tapioca pudding. How many people have, before moving into a commune?

The orientation is basically institutional but a lot of that kind of procedure and method is right at home in a commune family serving type situation. The most important thing the book does is show the cook that it's done all the time.

In my opinion the recipes are basic, that is, I would add here and there seasonings, etc. to make the food special, new, hopefully an experience and not just another meal. Like all cookbooks this finally becomes a guide rather than a road but it will show you a road and act as a guide until the process becomes intuitive. Also, after a few weeks, or months, cooking creatively can get a bit strained. Cookbooks will pull you through with the advantage of this one already being adjusted for a large group. One of the best dollar tools a community could buy.

[Reviewed by Steve Katona]

**Quantity Recipes**  
Marion A. Wood, Katharine W. Harris  
1945, 1966; 233 pp.

**\$1.00** postpaid

from:  
Cornell Home Economics Extension  
New York State College of Human Ecology  
Mailing Room  
Building 7, Research Park  
Cornell University  
Ithaca, N. Y. 14850

Another means of decreasing the cost of a recipe is by extending the more expensive items with cheaper ones. Meat stew is used as an example:

**MEAT AND VEGETABLE STEW**

Yield: 50 servings

3 servings per pound of meat	Price per unit	5 servings per pound of meat	Price per unit
15 pounds beef . . . . .	\$10.65	10 pounds beef . . . . .	\$7.10
1 cup onions . . . . .	.01	1 cup onions . . . . .	.01
2 quarts carrots . . . . .	.14	3 quarts carrots . . . . .	.21
2 quarts potatoes . . . . .	.12	3 quarts potatoes . . . . .	.18
1 quart celery rings . . . . .	.09	1 1/2 quarts celery rings . . . . .	.14
1 1/2 quarts (2 1/2 pounds) peas, frozen . . . . .	.45	2 1/2 quarts (4 pounds) peas, frozen . . . . .	.72
Total cost . . . . .	\$11.46	Total cost . . . . .	\$8.36
Cost per serving \$0.23 (\$11.46 ÷ 50)		Cost per serving \$0.167 (\$8.36 ÷ 50)	

The cost of left-over foods used in recipes should be included when figuring costs.

Average serving size and cost of serving, 1966, are given in the appendix.

While you're at it, get their free catalog of Bulletins, which lists innumerable titles on food, kitchens, shopping, clothes, flowers, etc., at low cost.

[Suggested by Roger Knights]

**FRUIT BROWN BETTY**

Yield: 50 servings  
10 pounds prepared fruit\*  
2 quarts crumbs  
1 teaspoon cinnamon  
1/2 teaspoon nutmeg  
1 1/2 pounds (3 1/2 cups) sugar, brown  
2 quarts fruit juice and/or water  
1/4 cup lemon juice  
1/2 cup butter or fortified margarine

Size of serving: 1/2 cup

1. Prepare the fruit and the crumbs.
2. Combine the spices, sugar, fruit juice, and lemon juice. Arrange the crumbs and sliced fruit in layers in greased baking pans. Begin and end with crumbs. Over each layer pour some of the above mixture.
3. Place dots of butter over the top layer. Bake at 350° F. for one hour. Add more water or fruit juice if mixture seems too dry.

Garnish with:  
Whipped cream or lemon or other fruit sauce or hard sauce  
\*Fresh, canned, frozen, or dried (stewed) apples, peaches, apricots, or plums may be used.

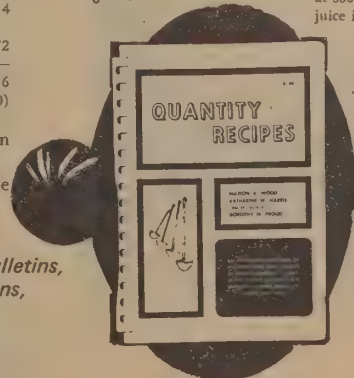

**\* Earth Flag**

A gentleman named John McConnell came into the Truck Store a few weeks ago and said that since all the nations have flags, and the UN has a flag, and states and businesses have flags, maybe there ought to be a flag that's just for people. So he got together with artist Norman LaLiberte and one of the Apollo Earth photographs and came up with the Earth Flag. I don't know if I'd die for it, but it's the first flag I've seen that I don't feel it somehow excludes me. The Earth Flag feels nice to wave.



Earth Flag (11" x 13" with staff)

\$1.50 postpaid from:

"WE" Inc.  
19 Troutman Street  
Brooklyn, N.Y. 11206

OR WHOLE EARTH CATALOG

**\* Vocations for Social Change**

This nifty service has been going for about a year now and is clearly growing in effectiveness. They earn your donation.

**INTRODUCTION**

Vocations for Social Change is a decentralized clearing house for persons struggling with one basic question: How can people earn a living in America in 1969 and ensure that their social impact is going to effect basic humanistic change in our social, political and economic institutions? Nobody has any "real answers" to this question, but many ideas are being developed out of people's experiences. VSC helps make these ideas available to the general public so that each person's individual search can be enriched.

This newsletter serves as the main gathering point for ideas with which we have come in contact. Not only do we include descriptions of job openings with groups working for social change from a wide variety of viewpoints, but also proposals for new projects that need help in getting started, descriptions of places where you can learn more about social action in an educational setting, and articles on topics related to working for social change on a full-time basis. What all of the people behind these various ideas have in common is a genuine concern for stimulating basic change in American institutions.

Informing you of available opportunities for involvement in social change is only part of our goal. We also hope that the information that we have gathered here will stimulate you to think about what new roles need to be created and to consider the possibility of actually finding a new role for yourself. Many more dedicated people are needed if we are to see significant change in our lifetimes.

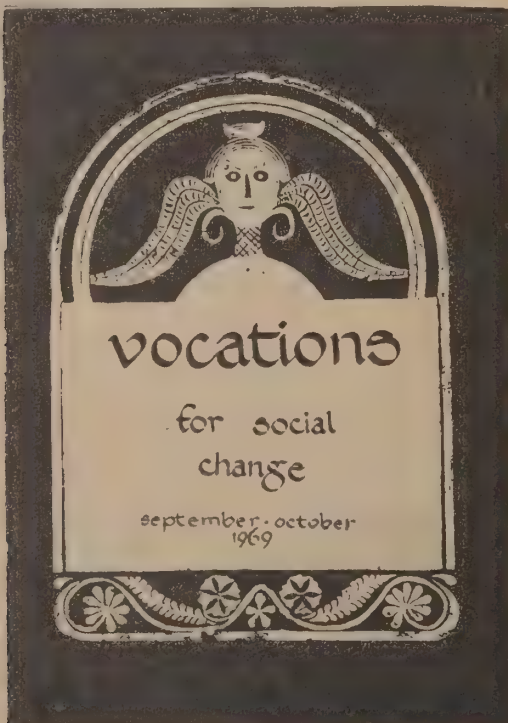

IF YOU WANT TO RECEIVE THE NEWSLETTER we'll be happy to send you a sample copy. We send VSC regularly for six months to people who support us financially with donations of \$5.00 or more, or send us monthly pledges. This helps cover the costs of mailing and enables us to send sample copies to those who cannot afford to send any money. Institutions, such as libraries and schools are charged \$10.00 a year.

**\* A Manual of Simple Burial**

Not everybody has an opportunity to depart this world gracefully, and those that do usually blow it. The people left behind fumble just as badly, for largely the same reasons: ignorance, fear, a lack of foresight and preparation. None but the dead can know for sure the full consequences of the failure. But even if there are no consequences for the dead, there are enough of them for the survivors in the forms of trauma and ruptured bank accounts, to make this Manual of Simple Burial seem something like a life-saver.

For this little manual of death is firmly on the side of life. As part of the literature of funerals, it's like a living rosebud in a bouquet of plastic flowers. In 64 pages it quietly tells you how to avoid the ghastly system of converting human left-overs into products packaged as "funerals." In simple language backed by intelligent sympathy, it suggests ways to surround the act of passage with appropriate rites of passage that offer real meaning to people in need of meaning.

According to the manual, the main alternative to expensive, hastily-improvised funerals is membership in a memorial society. A memorial society is "a voluntary group of people who have joined together to obtain dignity, simplicity and economy in funeral arrangements through advance planning." The manual provides a list of several societies by name and address. It also has information on cremation, autopsies, eye-banks, bequeathal of bodies, and the business and legal matters that usually attend a death, as well as chapters with titles like "Interpreting Death To A Child," and "What to Do When Death Occurs."

Men choose their horrors. We choose war. We choose pollution. And, by default, we choose to make the rituals surrounding death grotesque. But what is chosen can be unchosen, once an alternative is clear. The Manual of Simple Burial describes a clear alternative to one of our chosen horrors.

Reviewed by  
Gurney  
Norman

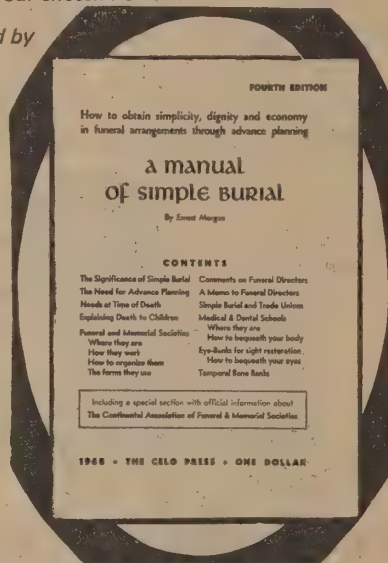

A Manual of Simple Burial  
Ernest Morgan  
1968; 64pp.

from:  
The Celso Press  
Burnsville, North Carolina 28714

\$1.00 postpaid



Figuring out how much to mark-up the price of the goods over what we paid for them was another real mystery. We were aware that many co-ops are short lived because they try to be a miracle store in the beginning by charging very little for the food before they fully understand how much money it takes to run the store. A number of other small grocers in town told us that we couldn't survive on less than a twenty percent mark up. Yet at that mark up we would be pricing ourselves at least five cents above the average supermarket price. We didn't know how much our overhead was going to be so we couldn't calculate it on that. What we ended up doing was taking a chance. If we could operate on volunteer help for several months then we could charge supermarket prices and try to get a lot of people to continue buying at the store out of something more than simple loyalty. Using every night's receipts to increase the stock, we managed to attract even more people by having a larger and larger stock every time they came in. We also did things like compensating for marking staples down by keeping luxuries at about a 20 per cent mark up. Having everyone a volunteer made the store a real community project with many different people working in the store day and night - a constant party or freak show depending on what time of day you came in.

**\* The Moonlighter's Manual**

Moonlighting means having a second job. Lots of people don't have a first job or want one. Birds of this feather flock economically together and pool resources for rent, food, dope, etc.—which still requires some modest income. Moonlight-type work may be the answer. Most of the income-sources in this book are part-time, or do-at-home, and involve low commitment of psyche (an advantage they have over stealing or dope peddling). The book includes a good list of technical training schools.

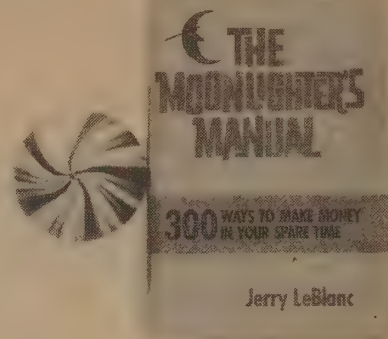

**BE A LOCKSMITH**

Picking locks, installing them, or making keys, freeing people from locked rooms, or getting them into their locked homes and cars, is an art that mystifies most people, thus making the locksmith in any town a respected craftsman. But actually, almost anyone who can work with tools and has a steady hand for dealing with tiny objects can master this craft and make a secure and profitable living from it. Generally this is a job for a self-starter, whether he pursues it full time or part time. The more than three hundred tools of the trade are the secret; they really do the work.

**Earnings**

Some beginners report averaging \$3 to \$10 an hour in their spare time, while learning, and those who set up their own shops, either in their homes or in a small, rented downtown store, come closest to the higher figure. And it's almost 100 per cent profit.

**Hours**

Variable. This job can be placed on a regular workday basis if you concentrate on installing and replacing locks and key-making, and there are always many jobs that can be done in spare time at home. But there will always be emergency calls, too, and these can mean an hour's rush work at any time of day or night.

**Requirements**

If you can concentrate on simple diagrams, follow instructions and handle small tools, you can learn this trade quickly, studying in your free time at home and gaining practical experience by working with actual car locks, home locks, safe locks, and padlocks. You'll also need a car for transportation, of course.

**Future**

Some large-traffic supermarket and department stores are glad to set up a locksmith with the space he needs, just for the service to their customers, although they will expect a commission or rent for their ideal situation. But opening your own shop is a distinct future calling, and you can double your earnings by selling locks, keys, and safety devices, too.

**For Information**

Write Locksmithing Institute, Little Falls, New Jersey 07424.

American Tuning School, Gilroy, California 95020. Home study in piano tuning.

Anderson School of Scientific Massage, Princeton, Illinois. Professional massage taught by mail; diploma awarded.

The Moonlighter's Manual from:  
Jerry LeBlanc  
1969; 150 pp.  
Nash Publishing Corporation  
9255 Sunset Blvd.  
Los Angeles, Calif. 90069

\$4.95 postpaid

OR WHOLE EARTH CATALOG



Sample copy  
free

from:  
Vocations for Social Change  
Canyon, CA 94516



**The Modern Utopian**

Intentional communities by now constitute a realm of activity worth having a magazine. This could be it, except it seems to be coming out at greater and greater intervals. It's well edited, with each issue on a specific aspect of the trend (communal schools, street people, etc.).

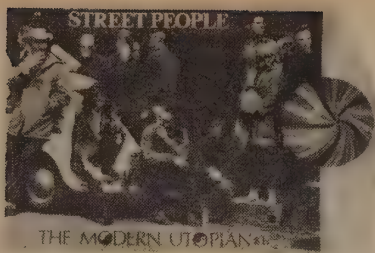

The Modern Utopian / A Way Out  
Dick Fairfield, ed.

\$4.00 for one year (quarterly)

from:  
The Modern Utopian  
2441 Le Conte Avenue  
Berkeley, California 94709

Starting a community farm is an incredibly difficult thing. We didn't fully realize this when we began. Setting up a new farm -- or rather, rehabilitating an old and neglected one -- was at least a season's work. Not to mention compensating for the work which should have been done the previous autumn.

Whether it is guarding a shrine, making electric music, applying Gestalt Therapy or feeding transient hippies, all viable communities have a conscious intent and meaningful function. As opposed to the lack of meaningful direction in today's American society, a conscious sense of purpose is the actualizing force if the community is to be more than a particularization of the social malaise it seeks to answer. Functions may change, sometimes with a rapidity which causes misunderstanding within the community; these changes, how they occur, and the control of change must be understood throughout the community.

Dear Friends,  
I have spent over twenty years in what is now called the "Hippie Movement", living in short-lived communes based on an anarchistic freedom and long-lived communes based on religion, taking part in political activities such as CORE work in the early 50's and the political action era of the Sexual Freedom League, and writing for, drawing for and editing little literary reviews and underground newspapers. This experience has brought me, gradually and reluctantly, to certain conclusions that I'm pretty sure some of your readers will dispute, yet to me they seem inescapable.

First, those communes based on freedom inevitably fail, usually within a year.  
Second, those communes based on authority, particularly religious authority, often endure and survive even against vigorous opposition from the outside world. (The best example of the strength of religious authoritarianism is the monasteries and nunneries of the Catholic Church.)  
Now, then, can an intentional community possibly be superior to conventional society? If the intentional community hopes to survive, it must be authoritarian, and if it is authoritarian, it offers no more freedom than conventional society. I am not pleased with this conclusion, but it now seems to me that the only way to be free is to be alone.

ORO, El Cerrito, Calif.

**Wildcrafters**

If you think longhairs are the only people running for the woods before the smoggy sky falls in, *The Wildcrafters* publications may broaden your view. They're the work of old geezers who groove on hunting and gathering food and fantasizing and opinionating about independence just like thee and me. Maybe we ought to get together and have a geezer conference.

**SURVIVAL HINTS**

AWARE of slipping, tripping or falling.

**Wildcrafters World**

\$1.00 yearly  
Homesteaders and  
Wildcrafters Newsletter  
\$2.00 per year (6 issues)

and assorted \$1.00 manuals

from:  
Wildcrafters Publications  
P.O. Box 118  
Rockville, Ind. 47872

USING AGAR AGAR AND VITAMIN B1 to start a peach tree. The kernels are removed from the hard pits of the peach seed and soaked in a solution of agar agar and vitamin B1 for three weeks. They sprout rapidly and are moved to clean washed sand, where they are kept moist for three weeks longer. Seedlings are then husky and large enough to be placed in soil filled pots. By the time they are nine months old they are ready for field planting and by their second birthday they should produce peaches. Sent in by Mrs. Zoller, Canada.

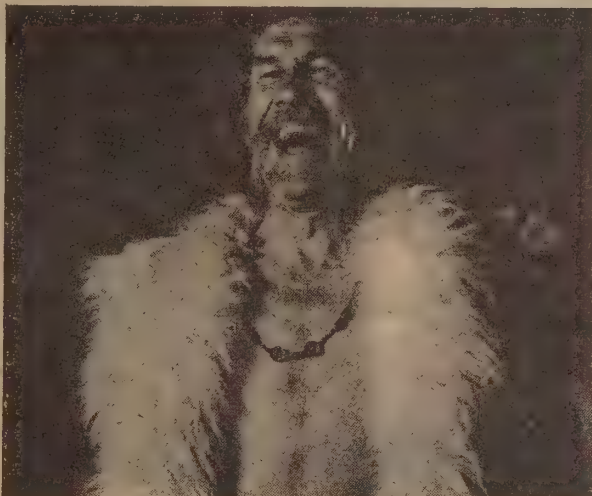

Far away I could hear the roar of the falls. Catatonic and gibbering I rose to the rear. Also Butch lifted me up. We climb a final knoll and ooowee. Natural fuckin wonder Jim! The majesty of all that water flashing and crashing like a moving post card. Without camera or guard rail or tour guide or beer can . . . not even the plastic music that pervades most national scenery marts.

This place was special because you had to earn it. Here come Bonnie Jean and White rabbit and David LeBrann all wasted from the walk. But the falls fixes all. Quivering with dying sun shouts rose and orange, rusty like the lord's own snot she set us down to worship while the sun sunk into sleep.

Let's take a quick look at the black-board. All us earth people are holding hands in a circle. Whether we know it or not. We are all dancing and chanting and making our own individual sound which makes up the whole racket of life. Now somewhere along the line the circle turned in on itself so the folks in the middle are squished and screaming like hell. Maybe that's where Hell is . . . in the middle of that circle . . . Hiroshima . . . Dachau . . . Vietnam . . . Bellevue. Just close your ears and you can hear 'em. Now what we can do is help relieve the pressure by absorbing a taste of the tug. Pass it on. Trust your neighbor. Trust your trust. Practice makes perfect and everybody wants to be practice. Open the whole thing up so everybody's comfortable. Take a deep breath and start all over.

It gets real cozy in the center when everybody's watching out for everybody else like at Yale University. In the middle of all rock and roll my brother-in-law let loose 5 live frogs . . . on cue . . . I grab a mike. "Don't anybody move! Some nut has just let loose 5 live frogs!" And the hunt was on . . . like looking for jumping contact lenses but we brought 'em back alive. It was a calculated risk and it worked. Later we all laid on the floor with his head on her tummy and her head on somebody else. Not freaky at all but warm and snuggly. After a while I asked to be passed around. Over the top of the pile. Everybody lend a hand . . . and I'm skimming

BEAUTIFUL NATURAL GRAIN CEREAL - PUT ALL THE GRAINS IN A LARGE CAN - MILK - THIS CAN WILL LAST 4 PEOPLE 2 MONTHS - EAT IT EVERY DAY AND STRENGTH WILL COME TO YOU - WARM MILK AND HONEY OVER IT - MILK AND SUGAR - COOK IT LIKE OATMEAL - FOR CAMPING ADD WATER

- 6lbs. of OATS
- 6lbs. WHEAT FLAKES
- 6lbs. RYE FLAKES
- 3lbs. WHEAT GERM
- 3lbs. SUNFLOWER SEEDS
- 1 1/2 lbs. PUMPKIN SEEDS
- 4-6 lbs. RAISINS
- 3-5lbs. DRIED FRUIT
- 3oz. RICE POLISHINGS
- 2oz. SOY LECITHIN
- 3oz. GROUND CHIA SEEDS (USE BLENDER TO GRIND)
- 2lbs. NUTS
- 1 lb. SOY FLOUR (OR CORN FLOUR)
- 3lbs. SESAME SEEDS
- ORGANIC FAMILIA

ADD ANY SOFT CHEWABLE GRAINS YOU LIKE - KEEP ADDING TO IT - ALWAYS CHANGING

*eat and enjoy*

"Dinner begins with a song followed by a short meditative silence. Sometimes a record is played, or the news listened to. During dinner we report on the day's happenings at our jobs, things we've read, and discuss the news. Around dessert we share the day's mail. Then dishes and lunch-packing. Usually Connie and Rae--either separately or together--prepare dinner. The men usually either wash or rinse dishes. Connie packs lunches one week, Rae the next.

**THE GREEN REVOLUTION**

A WORLD-WIDE EFFORT FOR DECENTRALIZATION AND RURAL REVIVAL

Volume 7, Number 7 September, 1969 \$6 per copy, \$24 per year

**Environmental Defense Fund**

EDF is one of the growing number of ways in which you can participate in the growing struggle against pollution of our world. In addition to the efforts of EDF and its local supporters brought changes in polluted parks and the earth has been established.

**Rules For A Community**

This is a breakdown of the rules of the Green Revolution. It is not a list of rules, but a list of principles. It is a list of things that we think are important to the success of a community. It is a list of things that we think are important to the success of a community.

**How To Compost**

This information, and the events that followed it, resulted in the

**The Realist**

If The Realist is the father of recent underground newspapers, Green Revolution is the mother of community newsletters. Both are kind.

The Realist  
Paul Krassner, ed.  
\$3.00 postpaid

from:  
The Realist  
595 Broadway  
New York, N.Y. 10012

**Green Revolution**

Green Revolution  
Mildred Loomis, ed.  
\$3.00 for one year (monthly)

from:  
School of Living Center  
Heathcote Road  
Freeland, Md. 21053

Cardinal principles: (1) If it's late try to get out at an all night cafe or truck stop (truckers aren't supposed to pick you up due to insurance rules, but especially at night they do it anyhow and sometimes you can curl up in a long-haul sleeper). If there's no cafe, try at least for a 24 hour gas station—you can ask the people who come in for gas to take you along.

(2) Carry food. The kind that's good for you. Raisons and nuts and seeds and fruit and cheese and bread as unrefined as you can get it. Otherwise, travel as light as you can.  
(3) Always have identification and someplace you can call if it comes to that. Make sure not to carry alcohol or anything else not nice. Avoid Delaware and the State of Washington altogether if you're going by thumb. Arizona is risky too. Check your route if you can with somebody's who was just there.

(4) Remember that you can often offer something in exchange — companionship, most likely. One thing about hitch-hiking — you can go night and day, nonstop, either riding or scratching for rides. That's how you get speed. But if you're on one of those marathons it's likely you'll get tired. Sleep when you have to, but apologise first. People pick you up for somebody to talk to more often than not. Maybe it's just to help them stay awake. Maybe they want you to help with the driving. Do it if you can.

**teddy kennedy does the breast stroke**



**The Hog Farm**

by Hugh Romney  
"This is a story about the Hog Farm. It is a story about a group of people who are living in a commune. It is a story about a group of people who are living in a commune. It is a story about a group of people who are living in a commune."

**The Oakland 7**

by Frank Burdick  
"This is a story about the trial of the Oakland 7. It is a story about a group of people who are living in a commune. It is a story about a group of people who are living in a commune. It is a story about a group of people who are living in a commune."



along at a pretty good clip and it really felt nifty. Then we sent Tooker aloft. The baby of Barry and Moe. He's maybe two and bald like the buddha. Talk about total attention. Hand over hand . . . it was really quite grand with Tooker on top of us all. We can fly with the help of our friends.

The earth is ours, we aren't supposed to ride indentured when we travel on her.

## Boffing Equipment

We hereby nominate Jack Nottingham for a Nobel Peace Prize for the first significant advance in weaponry since the encounter group. As Gerd Stern used to say a lot, "contact is the only love," and these foam swords permit contact—with an un-pulled punch and no corporal damage. However the release of interpersonal energy is only one of the uses of boffers. They are a fine game, builder of psychic and physical skill. For one thing you learn about temper: it's an obstacle and a hazard—you get cut to pieces every time. You learn about other stuff as well, no teacher required; the wisdom is inherent in the doing. As the inventor proclaimed at the end of a public boffing match at the Fillmore West recently: "The sword is mightier than the pen."

[Suggested by Heliotrope]



1 set boffing equipment  
(2 foam swords, 2 hand protectors, 2 goggles)

\$11.00 postpaid

from:  
Jack Nottingham  
190 Emmet Court  
San Francisco, CA 94110

or WHOLE EARTH CATALOG



## \* Kama Sutra Oil

This material lubricates, warms, feels good, smells good, and tastes good. It's for making love with.

Kama Sutra Oil  
4 oz. bottle

\$4.25 postpaid

from:  
Kama Sutra Oil  
1800 North Highland  
Los Angeles, CA 90028

or WHOLE EARTH CATALOG

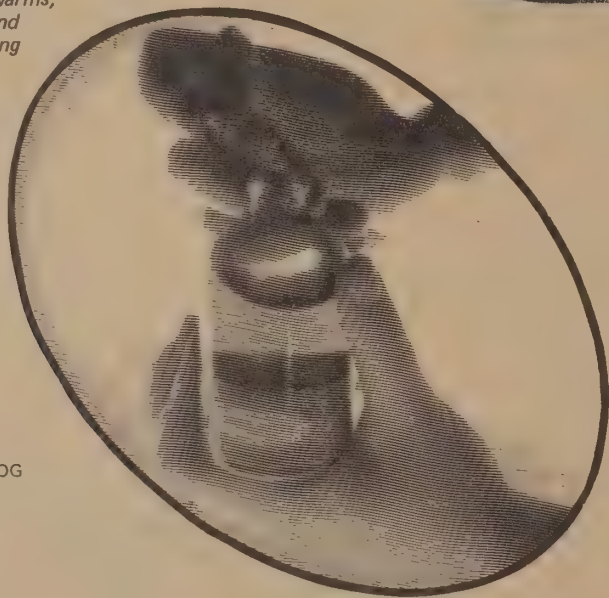

## \* Trimcomb

The barbershop has been obsolete for several years. Now trimmers and hair cutters follow. This absurdly simple item uses a double-edged razor blade (one edge trims, the other dry-shaves) to sculpt your hair with simple amateur dabs at your head. It works better if your hair is wet. Trimcomb costs about \$3 at most dime stores.

[Suggested by Dave Evans]



## Handbook of Prescription Drugs

A drug ordered by brand name can cost several times as much as the same drug ordered by generic name. This book spells out the difference, its reasons, and how to get generic name prices. One way is, ask your doctor when he's prescribing a drug to prescribe the generic name.

[Suggested by Hal Hershey]

The Handbook of Prescription Drugs  
Richard Burack, M. D.  
1967; 181 pp.

\$1.95 postpaid

from:  
Random House, Inc.  
201 East 50th Street  
New York, N. Y. 10022

or WHOLE EARTH CATALOG

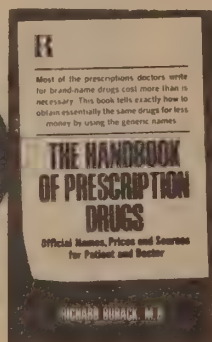

Mrs. Mary Brown, thirty-five, suffers from seasonal asthmatic attacks. One morning in the late summer she woke up with the familiar wheeze and shortness of breath which in the past had always signified the start of three weeks of misery. This year Mrs. Brown's doctor decided that there was no contraindication to trying a short, three-week course of a steroid drug. The treatment was dramatically effective. The doctor might have written either of the following prescriptions:

- (A) **R:** Mary Brown  
Meticorten 5 mgm  
Dispense 100 tablets  
Sig: Label. Take according to special daily dosage schedule as directed.
- (B) **R:** Mary Brown  
Prednisone 5 mgm  
Dispense 100 tablets  
Sig: Label. Take according to special daily dosage schedule as directed.

Prescription A would have cost between \$28 and \$30. Prescription B could have cost as little as \$3 at many drugstores.

We can refer to the drug dextroamphetamine, widely used for its appetite-curbing properties. The substance was patented by Smith Kline & French Laboratories, who alone sold it in vast amounts for a seventeen-year period under the brand name Dexedrine. The patent has long since expired, and as of now, half a hundred companies are marketing dextroamphetamine, nearly all at lower prices than Smith Kline & French. But the many new producers of dextroamphetamine may not advertise it as Dexedrine. If Dexedrine is the word the doctor writes on the prescription blank by force of habit, the druggist must by law in thirty-nine states (except within institutions) dispense Dexedrine—and at its brand-name price. It must be pointed out, however, that even if the prescription read "dextroamphetamine," the druggist would be free to dispense Dexedrine at the higher price, and that is exactly what many of them do, since it is not yet common practice for drugstores to keep in stock the less expensive—but for practical purposes identical—dextroamphetamine tablets marketed by other companies without the trade name Dexedrine. Such less expensive, non-brand name dextroamphetamine tablets are the "generic equivalents" of Dexedrine.

**Sauna**

The only book available on Saunas: what they are, the history, how to use and enjoy, and how to build one. Although the construction details are not extensive, there is a list of about 20 Sauna manufacturers who will send you free construction plans, in hopes that you'll buy a heating device from them.

[Suggested by Stan Gould]



The whole purpose of the sauna is to induce perspiration.

The simplest form of the family sauna is a one-room hut built of logs, with a large rudimentary stove upon which rocks are placed.... The heat of the sauna is non-radiant: that is, it does not radiate directly toward the bather but rather is absorbed in the stones which emit the heat into the air. The indirect heat is gentle and constant.... The stones are heated until they become red hot...ideal temperature 190-200 degrees...water is thrown on the stones but the air remains dry because moisture is instantly absorbed by the wooden walls... traditional sauna includes beating with leafy birch branches, washing, and a plunge in a nearby lake or roll in the snow outside. Then follows a necessary rest while the body cools down completely.

The need for a perspiration bath has arisen in those countries where people have had to do exceptionally heavy physical work.... After heavy work the limbs had to be made supple and strengthened before work could be continued.

There are several different kinds of platform. In some, a series of steps of which the top one is wider than the rest, where there is room to both sit and lie. In others, a wooden stairway leads up to the platform which is like a gallery on which stools and benches are placed.

If possible the sauna should face west, as people usually go into the sauna in the evening, very often at sunset. Then the rays of the setting sun streaming into the sauna room give one a feeling of intense calm. And, lying on the platform, looking out to the lake, one experiences a delicious foretaste of what the cool waters will offer the bather who plunges from the heat of the sauna into their depths.

**Sauna: The Finnish Bath**  
1965; 87 pp.

**\$3.95** postpaid from:  
Stephen Greene Press  
120 Main Street  
Brattleboro, Vt. 05301

or **WHOLE EARTH CATALOG**

Interior walls and ceiling are often built of kiln-dried, unfinished redwood, which does not shrink, does not warp, and is a poor heat conductor. Another excellent wood is cedar, which not only shares redwood's good properties but also emits a pleasant odor and does not stain with moisture.

Nailing should be done with hot-dipped galvanized nails to avoid stains from rust; nails should be counter-sunk whenever it is likely that a bather will touch them in the hot room. Tongue-in-groove paneling disposes of this problem in wall construction; benches can be screwed from below.

**BUILDING A FINNISH SAUNA**

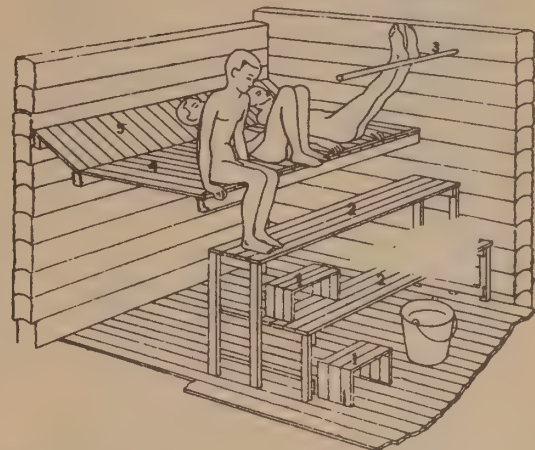

A practical arrangement: 1) small stools used as steps; 2) steps; 3) rail for propping up feet; 4) platform; 5) headrest.

**Massage**

People rubbing people is always nice. People rubbing people with skill is an order of magnitude nicer. The problem is acquiring skill; there don't seem to be books that really enter the subject in a friendly way. *Ida Rolf, I gather, teaches good technique, but you can't get her through the mail. So, until something better is inspired, this is the best massage book we've seen. It's medical, thorough, somewhat textbooky, but the illustrations are many and informative and what they teach feels very good indeed.*



Certain persons seem to possess a natural ability to relax their hands and to move them rhythmically, and they will learn the technique of massage more readily than others. However, anyone who conscientiously spends sufficient time in practice will learn contact and rhythm and acquire good technique.

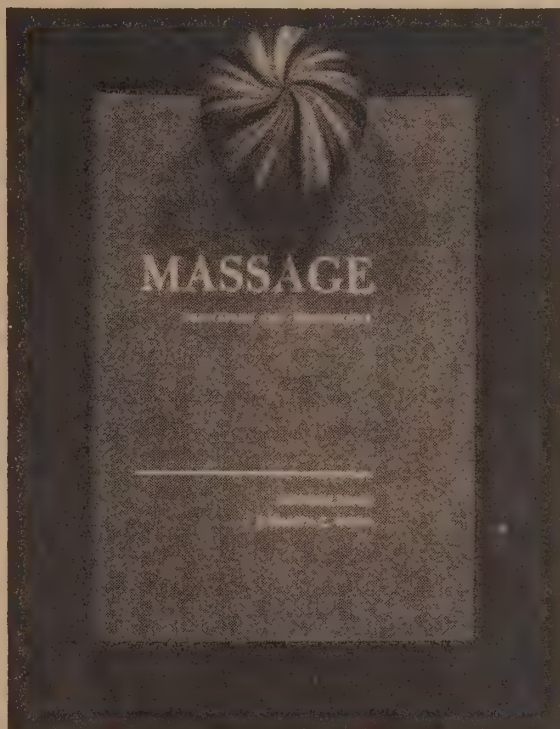

**Massage: Principles and Techniques**  
Gertrude Beard and Elizabeth Wood  
1964; 163 pp.

**\$6.00** postpaid

from:  
W. B. Saunders Company  
West Washington Square  
Philadelphia, Pa. 19105

or **WHOLE EARTH CATALOG**

In some instances, a fine unscented talcum powder or French chalk may be substituted for cold cream as a medium to prevent irritation of the patient's skin, but usually it does not permit as satisfactory a grasping of the tissues as does a cream lubricant.

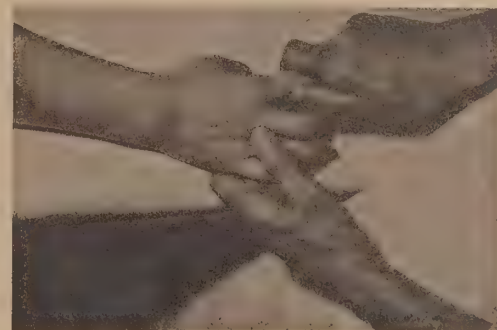

(a) The thumbs remain in the air, and the finger tips [without breaking the contact they have maintained at the temples in (2), (3), (4), (5), and (6)] simultaneously knead in small circles, starting at the temple (Fig. 134) and, following the hairline, continuing back of the ears until the fingers meet at the cervical spine (Fig. 135).

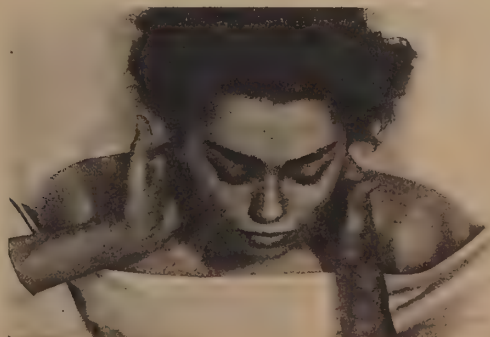

For the limbs, the stroke is usually in the centrifugal direction. The growth of hair naturally falls in this direction, and stroking performed in an opposite direction is unpleasant. The direction of the movement, once established, should be continued throughout the treatment.

**Dear Dr. Hippocrates**

Long-hairs are doing new stuff with their bodies and nervous systems that occasionally needs medical attention or perspective. Communication was blocked, however, by the social understanding that they aren't supposed to be doing that stuff. Dr. Schoenfeld and his medical advice column in the underground press cut through the blockage, and here came a spout of information as weird as it was useful. Good answers made the questions good.

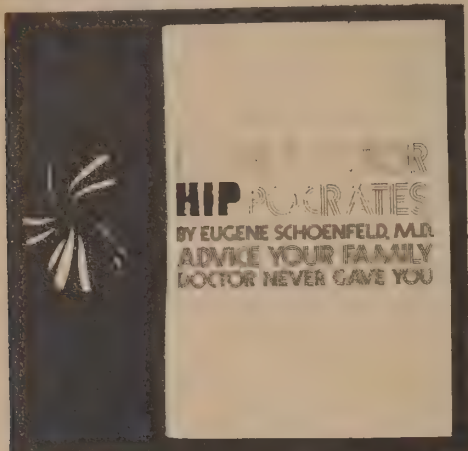

Dear Doctor Hippocrates  
Eugene Schoenfeld, M. D.  
1968; 112 pp.

\$5.00 postpaid

from:  
Grove Press, Inc.  
315 Hudson Street  
New York, N. Y. 10013  
or  
WHOLE EARTH CATALOG



Tell us about 'speed.' What happens to the body and brain when 'meth' (crystals and tabs) is taken in small and large doses?

'Meth' (methamphetamine) is used in medicine for appetite control, mood elevation, and to raise blood pressure when indicated. The drug is usually ingested in five-milligram tablets one to three times a day. Medical reasons for injecting methamphetamine are specific and few.

Tolerance to the amphetamines develops rapidly and increasingly large amounts must be used to achieve the same results. When large amounts are used, blood-pressure may be raised sufficiently high to blow out a blood vessel in the brain, thus causing a stroke.

True addiction, as well, seems to occur. Recently a patient in a drug-abuse clinic stated that it was harder for him to kick the 'meth' habit than it was to get off heroin. At the time he was shooting up two hundred milligrams of 'crystals' every two hours. He was found dead a few weeks later, apparently from an overdose.

An eighteen-year-old boy on methamphetamine climbed out of a third-story window in Berkeley not long ago. He is now confined to a neurological institute, completely paralyzed from the effects of a broken back.

Both general and student hospitals are seeing increasingly greater numbers of sixteen-to-twenty-five-year-old people who have caught hepatitis from a needle used to inject methamphetamine. Neither boiling water nor soaking in alcohol will necessarily kill the hepatitis virus found in too many spikes.

Speed kills.

For cosmetic reasons and sex appeal, I have been interested for some time in removing my pubic hair. I initially tried scissors which left stubbles; a safety razor leaves red marks and bumps which are both unattractive and painful. An electric razor is better but still unsatisfactory. I called an electrologist who removes hair, but she found my request most peculiar and refused to undertake the work.

Can you suggest a solution to the problem? Is there any reason to believe removal of pubic hair would be either unhealthy or dangerous?

Most Middle Eastern women routinely shave their pubic hair but I leave to you and your chafed friends the question of whether this practice will enhance your sex appeal. It does not seem medically dangerous.

Cautious use of a depilatory or one of the newer electric razors would seem the best solution to your problem. I would advise against permanent removal since you might someday move to a colder climate.

(Note: Judging from the volume of mail received in response to the preceding question and answer, shaving pubic hair is definitely not confined to the Middle East. Excerpts from three letters follow.)

A leading manufacturer of safety razors (Gillette) recently placed on the market something called a 'Scardy Kit.' The ad dealt with the problem of very brief bathing suits but the letter from the girl who shaves made me wonder. Perhaps she needs instruction in the use of lather or brushless cream.

She will have far better results if she uses an electric hair clipper such as the ones barbers use. The OOOO blade is the finest one and will not leave unsightly stubble, irritate the skin or cause abrasions.

For shaving, use alcohol - it eliminates abrasions and little bumps. This was told to me by a psychiatrist.

Have you ever heard of something called a 'hum' job? During fellatio or cunnilingus one vigorously hums a tune such as 'Jingle Bells.' What do you think of this?

Hmmm. Merry Christmas.

Can infectious hepatitis be contracted through cunnilingus?

This is an excellent way—if the recipient of your affection has the disease.

There's been a lot of talk lately about a new drug called MDA. What are its effects? Do the initials MDA mean anything or are they another put-on like the STP initials?

MDA is methylenedioxyamphetamine, a mind-altering drug derived from amphetamine. Both drugs were first synthesized (amphetamine in 1933) by Gordon Alles, who died recently in California.

MDA is an example of a mind-altering drug apparently specific to certain functions of the brain. If the LSD experience can be described as one including both perceptual or sensory changes and inner experiences such as insight, the effects of MDA could be said to be similar to LSD with few of the sensory changes. In other words, illusions and other changes in perceiving 'reality' are infrequent or absent with the use of MDA. The drug is said to promote harmonious interpersonal relationships.

MDA has not been extensively tested in humans and may have unrecognized harmful effects, as with any unproven drug. Moreover the MDA available on the black market may contain impurities.

Some men find that the application of an anesthetic ointment to the head and shaft of the penis half an hour or so prior to intercourse allows them to prolong their coital experience. Nupercainal is one such anesthetic ointment available without a prescription.

The Merck Index  
1968; 1713 pp.

\$15.00 postpaid

from:  
Merck & Co., Inc.  
Rahway, N. J. 07065

We've been told that the Merck Index can be even more useful than the Merck Manual. The Index is an encyclopedia of chemicals and drugs, now in its 8th edition since 1889.

[Suggested by William Bonner]



**N,N-Dimethyltryptamine. DMT; 3-[2-(dimethylamino)ethyl]indole.** C<sub>12</sub>H<sub>16</sub>N<sub>2</sub>; mol wt 188.26; C 76.55%, H 8.57%, N 14.88%. Occurs naturally in plants with hallucinogenic properties. Isola from the leaves of *Prestonia amazonica* (Benth.) Macbride (*Haemadictyon amazonicum* Spruce & Benth.), *Apocynaceae*: Hockstein, *Paradies*, *J. Am. Chem. Soc.* 79, 5735 (1957). Synthesis: Szára, *Experientia* 12, 441 (1956) using the method of Speeter, Anthony, *J. Am. Chem. Soc.* 76, 6209 (1954). Relationship between hallucinogenic activity and electronic configuration: Snyder, Merrill, *Proc. Natl. Acad. Sci. U.S.A.* 54, 258 (1965).

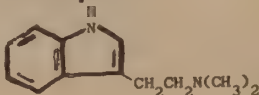

Crystals, mp 44.6-46.8°. pK<sub>a</sub> 8.68 (ethanol-water).  
Freely sol in dil acetic and dil mineral acids.  
Picrate, mp 169.5-170°.  
Methiodide, mp 216-217°.

**The Merck Manual**

In 1850 type-packed pages this book covers most of the possible illness and injuries that can occur to human beings. Each difficulty is described, symptoms are discussed and suggested treatments are indicated.

The writing is extremely technical and is designed as a ready reference for practicing nurses and physicians. Unless you are at ease with the unusually colorful language of modern medicine you will need a medical dictionary to fully understand this book.

While a considerable portion of the advice given is sensible and does not require a doctor's presence, much of the book will not be of use to persons who do not have access to medical supplies. This book is not intended in any sense for primitive or simple living conditions; it does not describe alternatives if medical treatment is not available nor does it suggest folk treatments in lieu of hospitalization. However, if you want to understand what is going on when a member of your family or community is seriously ill, this volume can be helpful. There is an excellent index as well as a special section devoted to specific prescriptions and special therapies. The excerpts given below illustrate both the common-sense and the technical aspects of this volume.

[Reviewed by James Fadiman]

[Innovator reports that many prescription drugs can be obtained without a prescription and at low cost from veterinary supply houses. —SB]

**DYSPEPSIA ("indigestion")**

**Treatment**

General: The patient should eat a balanced diet (see DIETS, Normal Diet). At least 1 hr/meal should be allowed. Food should be chewed thoroughly without haste and not constantly 'swilled down' with liquids. When possible meals should be taken in a pleasant, quiet, relaxing environment. Smoking immediately before meals should be prohibited. Food should be properly cooked, appetizing and eaten in moderate amounts. Following a meal, the patient should avoid excitement.

**HEAT HYPERPYREXIA (sunstroke, heatstroke, thermic fever, sirsiosis)**

Etiology: prolonged exposure to excessively high temperature or the direct rays of the hot sun, combined with exercise and lack of air circulation are the responsible factors. . . .  
Symptoms and Signs: Onset may be sudden or may follow complaints of weakness, headache, vertigo, anorexia, nausea and precordial distress. . . . The temperature rises rapidly to 105 or 106 F. or higher. Convulsions and projectile vomiting may develop and are of serious import. . . .  
Treatment: heroic measures are indicated and must be instituted immediately. If the rectal temperature is 106 F. or over, an ice water tub bath or a blanket soaked in water is indicated, and the skin should be rubbed vigorously until the temperature falls. . . .

**DISTURBANCES IN ELECTROLYTE (Mineral) METABOLISM** Dilutional hyponatremia will occur when excessive water is given to a patient in whom antidiuretic hormone activity (postoperatively, or in bronchogenic carcinoma, head injuries, or porphyria) or a low glomerular filtration rate is present. Movement of the water from cells in E.C.F. with a high glucose concentration may produce a temporary hyponatremia.



The Merck Manual  
11th Edition 1966; 1850 pp.

\$7.50 postpaid

from:  
Merck & Company, Inc.  
Rahway, New Jersey 07065

**PITUITARY-ADRENAL**

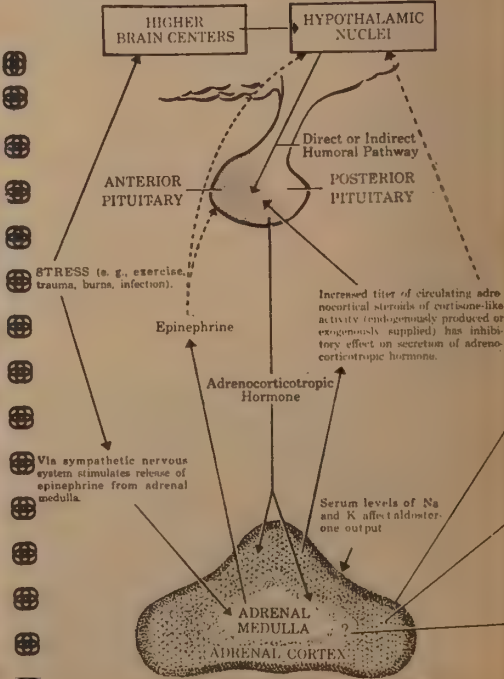

**Emergency Medical Guide**

No book can substitute for a physician's care. Self-treatment of disease can be worse than no treatment at all. But the proper use of a home health manual may be invaluable in recognizing serious diseases and emergencies, rendering first aid, and treating common medical problems which do not require a physician's assistance. Outdoorsmen and members of isolated farms and communes, especially, should have on hand as much medical information as possible.

Henderson's Emergency Medical Guide is a useful book, including illustrated sections on bandaging techniques, mouth to mouth resuscitation, injuries to extremities, poisoning, snake bites, emergencies of infancy and childhood, and home care of the ill. Emphasis is placed on the prevention of accidents and disease. Some situations are covered which are not generally considered emergencies (except by the patient) such as painful menstruation. A chapter on normal human anatomy and physiology is included in order to make the rest of the book more intelligible to those giving first aid.

[Suggested and Reviewed by Eugene Schoenfeld]

**Emergency Medical Guide**  
John Henderson, M. D.  
1963, 1969; 556 pp.

**\$3.95** postpaid

from:  
McGraw-Hill Book Co.  
Princeton Road  
Hightstown, N. U. 08520  
Manchester Road  
Manchester, MO 63062  
8171 Redwood Highway  
Novato, CA 94947

or WHOLE EARTH CATALOG



FIG. 8-9. Procedure for reducing a simple dislocation of a finger, applying pull on each side of the affected joint.

Thumb. Do not attempt to set a dislocation of a thumb. Because of its complicated anatomy, reduction may require a minor operation. Cover the thumb with a protective compress, support the hand in a sling, and seek medical aid.

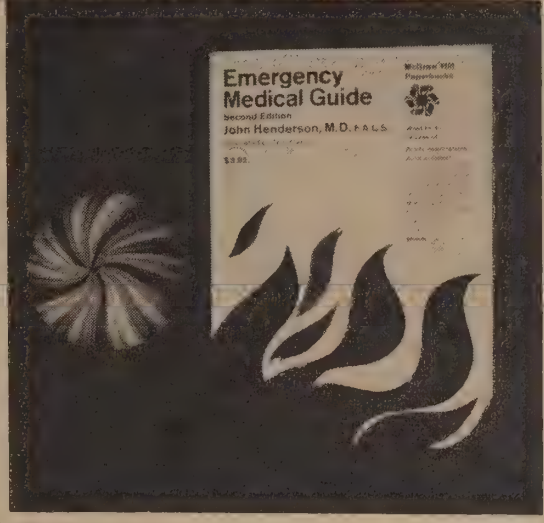

**SUMMARY AND CHECK LIST OF IMMEDIATE MEASURES**

Always treat the most dangerous and urgent condition first. Remember the four B's: breathing, bleeding, broken bones, and burns.

- A summary and check list of the fundamental general procedures follow:  
Whether or not the injured person is conscious:
1. Make sure that he is breathing. If he is not, begin artificial respiration immediately.
  2. If breathing is satisfactory, see whether he is bleeding. If the bleeding is profuse, take measures to control it immediately.
  3. When breathing is satisfactory and there is no evidence of bleeding, look for signs of shock and fractured bones.
  4. Obtain medical aid quickly—phone a doctor, get someone else to phone him, or get the injured person to a doctor or hospital.
  5. Work quickly, but carefully.
  6. Loosen tight clothing—collar, waistband, or belt.
  7. If the victim vomits, lower his head and turn it gently to one side so that the vomitus will not be aspirated.
  8. Remove any loose objects, such as artificial dentures, from the mouth of an unconscious person.
  9. Keep the victim quiet and warm. Do not over-heat.
  10. Don't give an unconscious person anything to drink.
  11. Don't aggravate an injury by unnecessary movements.
  12. Don't allow a person with a fracture or suspected fracture to be moved until splints have been applied or he has been fixed to an adequate back board in the case of possible spinal injury.
  13. Never urge an injured person to sit up, stand up, or walk until you are sure he can safely do so.

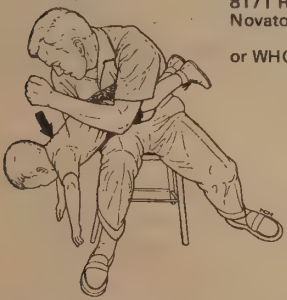

FIG. 4-1. Ejecting a foreign body stuck in child's windpipe by a sharp blow between the shoulder blades.

Those who are accustomed to handling epileptic seizures make little of the convulsions and do not become excited.

It is important to keep the victim of the attack from aspirating or choking on vomited matter, but since most attacks will terminate harmlessly by themselves, regardless of what you do or do not do, just protect the victim from injury and bide your time. When he recovers, do not be unduly sympathetic—you may only embarrass him. Give him a drink of water or tea, protect him from curious onlookers, and be sure that he is well enough to go on his way or that he is taken home. If the condition is more serious, see that he gets to a hospital.



FIG. 15-1. A cradle to keep bedclothes off legs and feet, made from a cardboard carton.



FIG. 4-11. Correct position of hands for external cardiac massage, using the heel of the hand to exert pressure on the breastbone.

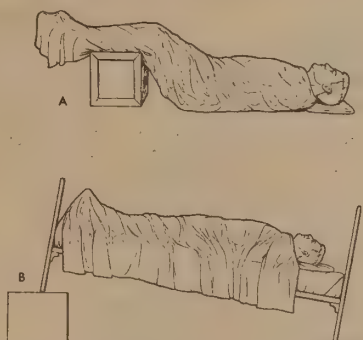

FIG. 8-1. Two methods of placing a victim in the shock position. A. Under emergency conditions, use a box or other device to elevate the legs. B. Under hospital or home conditions, use 'shock blocks' under foot of bed.

In the typical case the first definite symptom is usually a gripping, colicky pain in the pit of the stomach, followed in two to four hours by nausea and vomiting, which may be accompanied by a diarrhea-like feeling. After another four hours or so the pain shifts to the right lower side of the abdomen, which becomes acutely tender and spastic to touch. This latter symptom, following the above sequence of events, very strongly suggests the presence of acute appendicitis.

The treatment is prompt surgery. Never give anyone suspected of having appendicitis anything to eat or drink, except possibly little sips of water. Never give a laxative or any other medication by mouth until the true diagnosis has been clarified by a physician.

The patient should be placed in a semireclining position, head and trunk raised about 30 degrees from horizontal, with a pillow under his knees to keep them flexed, and an ice bag, wrapped in a towel, applied to the lower right side of the abdomen.

The patient should be seen by a doctor as quickly as possible and arrangements should be made to get him into a hospital.

**\* Pregnancy, Childbirth and the Newborn, A Manual for Rural Midwives**

This manual was first published in 1950 to teach women and girls in China who had very little education. Since then it has been enlarged and adapted to other countries, so that it is now also published in Portuguese, Spanish and English.

Lessons include anatomy, physiology of the female reproductive organs, the progress and conduct of pregnancy and childbirth, and the care of the newborn. The illustrations and directions will certainly aid anyone interested in a home delivery, since the manual is written for rural midwives without access to modern, sterile hospitals. The suggestions are practical and economical.

[Suggested and reviewed by Haru Bekker]

**Pregnancy, Childbirth and the Newborn, A Manual for Rural Midwives**  
Leo Eloesser, Edith Galt and Isabel Hemingway  
1959; 150 pp.

**\$1.25** postpaid

from:  
Niños Héroes, 139  
México 7, D. F.  
MEXICO

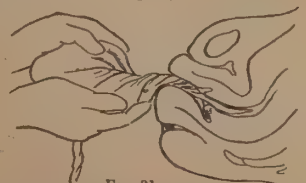
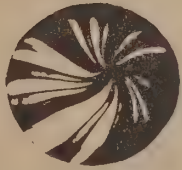
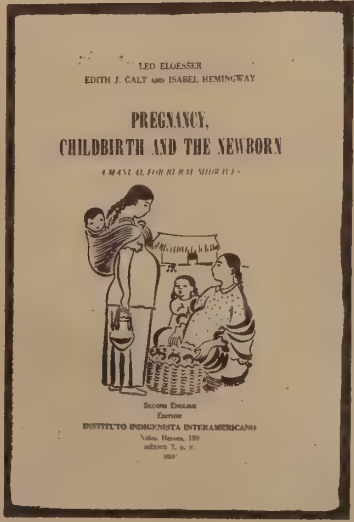

FIG. 31. Delivery of the placenta. Twisting the membranes after expulsion of the placenta helps prevent tearing and retention of membranes.



**COMPLICATIONS OF DELIVERY**

**Breech Delivery**

In about 3% of all deliveries the breech presents. There is not much danger for the mother, but 10% of breech babies die, many of them from trouble with breathing (asphyxia). If properly handled the danger is much less.

**Conduct.** If a breech presentation is diagnosed in a first pregnancy, get help for the delivery or send the patient to a hospital, if possible.

If the patient has had other babies, or is in active labour, do your best to deliver the baby.

Measures to hasten delivery, such as an enema or having the mother walk, should be omitted.

When the presenting part is in sight do not hurry but let the buttocks stretch the perineum slowly. Let the mother deliver the baby. When the whole body is born, support it on your left hand and forearm, using the middle finger of your left hand to find the baby's mouth and make complete flexion of the baby's head. At the same time, press on the fundus with the right hand, or ask a helper to do so, and the head will be born. Do not pull on the baby at any time.

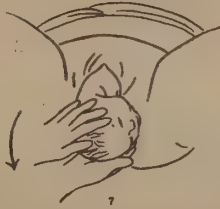

Delivery of anterior shoulder.

★ **The New Childbirth**

The book is complete with many explanatory diagrams and some photos of an exuberant mother giving birth to her child with little aid from the mid-wife. The chapter on B-Day is especially vivid, simple, and beautiful. It is difficult to remain unmoved as the faith of this woman in the naturalness of birth unfolds. But not only does she have a faith; she has a system that works.

[Reviewed by Jane Stallings]

**The New Childbirth**  
Erna Wright  
1964, . . . 1968; 246 pp.  
\$1.25 postpaid

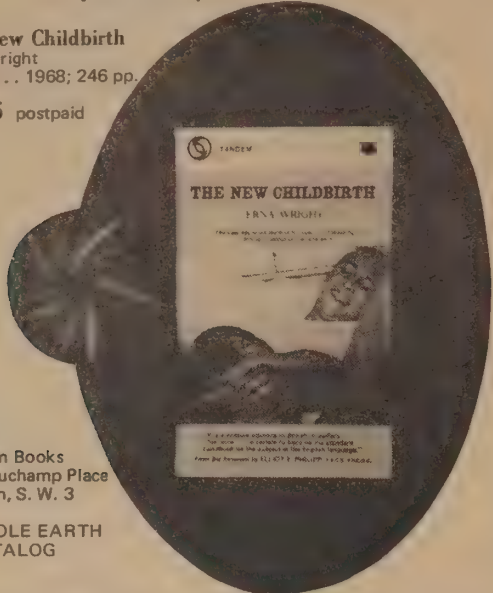

from:  
Tandem Books  
33 Beauchamp Place  
London, S. W. 3

or WHOLE EARTH  
CATALOG

What can a "trained" mother hope to accomplish? From the labour reports sent to me by my ex-pupils, it would seem that 35% of them have experienced a painless labour. Not a sensation-less labour because any body-experience will result in some sensations; but a labour during which none of the sensations, however strong, were interpreted as pain by the woman herself.

I always tell husbands not to argue with a woman in transition stage. It's useless. You might as well talk to a brick wall. You may even get to a point where on this emotional level you feel that the whole world is wrong, that everyone is treating you frightfully badly. If you do feel weepy, for heaven's sake have a little weep. Don't sit there swallowing it. If you do you will only feel more miserable than ever.

If your baby has longish hair, you may feel it tickle as the baby turns inside the vagina. But you may not be aware of it. But if you do feel it don't shout at everyone "Stop tickling!" They are not there to tickle you, and their hands are usually occupied elsewhere. This is only the first of many situations where your child will be doing ticklish things to you. The baby may also cry; it is a very odd sensation, hearing your baby cry before you've even seen it, and you don't know whether it is a boy or a girl.

At the height of this kind of contraction, which you will generally not experience until after three fingers' dilation of the cervix, you need Level D breathing. (The light natural breathing which your chest will automatically adopt if you concentrate hard on your tune and beating its rhythm with your fingers.) As the contraction fades again, you come down through the levels with it, making up the oxygen debt created by the vigorous activity of the uterus. When you feel that the contraction has gone, take an extra breath in Level A to ensure that your tummy-muscles are at rest.

After that, you can wipe your brow, sip some water and discuss the Italian Renaissance if you want to. The trade union rules for women in labour say that when the uterus is not working you don't work either!



If you want to have some rough idea of how much work will be done, look at the size of your sitting room. Imagine it has no carpet but just a wooden floor. Imagine you are a Victorian woman and with a bucket of lukewarm water, a bar of soap and a scrubbing brush, you are going to get this floor clean on your hands and knees. None of this TV commercial business with a modern mop and a detergent that whisks over the floor in 60 seconds flat. But real old-fashioned elbow grease. If you can imagine even faintly how much work this would take, then you have a rough idea how much work your body will undertake. Because as I said, 80% is done by the uterus. Even though it may not seem like it at the time, nevertheless it is true. So it is hard work. But it is satisfying work because you know you are getting places at last.

**How to Save the World: have fewer children and better ones.**

The population problem is simple. If you have more than two children of your own, you're part of the problem. Two children or fewer or adopted kids, you're part of the solution.

★ **How to Adopt a Child**

If infertility or population concerns are frustrating your desire for children around the place, adoption can be an adventurous solution. This book details what you can expect in adoption procedure, compares the adoption regulations in the various states, and lists all the U. S. adoption agencies. Roy Rogers and Dale Evans adopted a whole rainbow of kids from overseas.

In recent years, once a home is approved by the agency, placement of a child almost always follows. Further, the time necessary to determine home eligibility has been steadily decreasing. The average time necessary for a private agency to approve or disapprove a home for adoption has dropped from nine months to six months in the period 1958 to 1962. In the same period, public agency time required dropped from six months to four months.

Agencies have also grown more flexible about their age requirement in recent years. Similarly, the number of years a couple has been married is not as important as it used to be. Religion is another area where agency policy has become increasingly more flexible. Even the fact that applicants have natural or other adopted children is of declining importance. Agencies are becoming more concerned, as well they should be, with finding the proper home, one where the child can grow up in a stable and understanding environment. Of course, the adoptive parents still have to satisfy certain statutory requirements (as well as other requirements that the agency might impose), and these requirements are less susceptible to change.

To sum up, there are an increasing number of children available for adoption, and agencies are reacting to this trend by being more flexible in many critical areas.

**How to Adopt a Child**  
Robert A. Farmer  
1967, 1968; 153 pp.

\$4.95 postpaid

from:  
Arco Publishing Company  
219 Park Avenue South  
New York, N. Y. 10003

or WHOLE  
EARTH  
CATALOG

The proper procedure for adopting a foreign orphan is by means of an authorized placement agency. Two such agencies have handled the major part of United States placements of foreign children. These are the International Social Service and the National Catholic Welfare Conference. These agencies have been able to supply foreign children to American couples in most cases for a fee of less than three hundred dollars.

In recent years, the number of white children adopted has been approximately ten times greater than the number of nonwhites adopted. However, nonwhite adoptions are increasing at a faster rate than white adoptions.

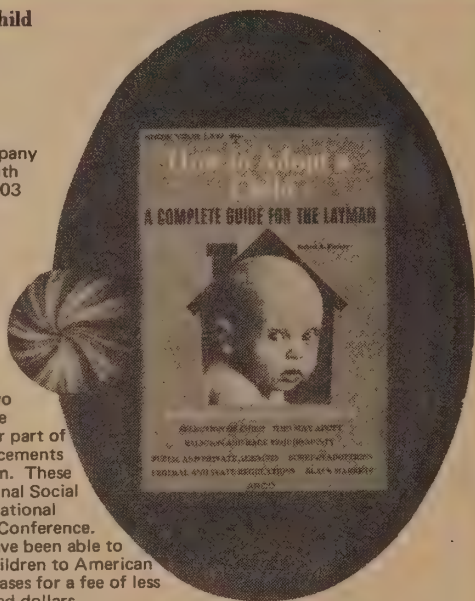

★ **Preparation for Childbearing**

This is a thoroughly practical handbook. The suggestions if followed for carrying, climbing, lifting, breathing, and conscious relaxation are sound suggestions for the pregnant woman or anyone, for that matter. One chart on the Relief of Common Discomforts that May Occur During Pregnancy matches a discomfort with an exercise or position to alleviate it. The book does not advocate "Natural Childbirth" but rather suggests that each person is individual in his need for anesthetics; its aim (by use of many illustrations) is to make pregnancy, childbearing, and post partum as comfortable as possible.

[Reviewed by Jane Stallings.  
Suggested by Haru Bekker]

**Preparation for Childbirth**  
1963, 1969; 47 pp.

FREE OR CHEAP

from:  
Maternity Center  
Association  
48 East 92nd St.  
New York, N.Y.  
10028



<p><b>ONSET OF LABOR</b> You may notice any one or a combination of Regular contractions felt as back-ache, pelvic pressure, gas, menstrual cramp, etc.) Show Rupture of membranes</p>	<p>Check sign; time contractions. Call doctor and report. If day/time continue usual light activity activity. If night, rest.</p>
<p><b>EARLY FIRST STAGE</b> Cervix effacing, dilation beginning Contractions become strong enough that you feel need to do something. Dilation continuing; contractions becoming somewhat closer and stronger</p>	<p>When contractions start, breathe out and relax. Continue slow deep breathing through contraction. Try sitting positions (9). In between contractions rest, read, watch TV, etc. Go to hospital as doctor directs. Relax as much as possible in sitting or lying positions during travel and admitting procedures. Lie on side, breathe deeply and slowly while rocking pelvis very gently throughout contraction (11).</p>
<p>If contractions are causing backache</p>	

★ **The Womanly Art of Breastfeeding**

Want to nurse your baby? The Womanly Art of Breastfeeding prepared by the La Leche League offers a complete guide of "how to", as well as a philosophical treatise on "why to".

Chapters include suggestions on how to prepare the breasts, how to get reluctant hospitals to cooperate with breastfeeding, how father can help, and weaning processes. In our opinion the book represents the most complete and useful information available concerning breastfeeding.

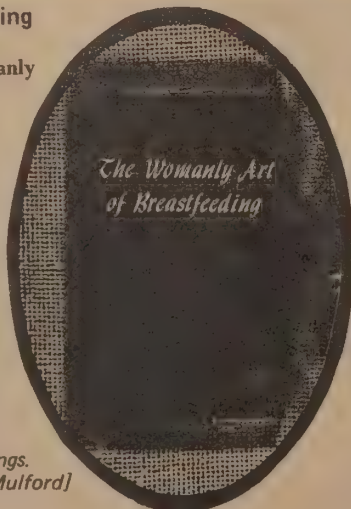

86 [Reviewed by Jane Stallings.  
Suggested by Christine Mulford]

**The Womanly Art of Breastfeeding**  
1958, 1963; 166 pp.

\$3.00 postpaid from:  
La Leche League International  
Franklin Park, Ill. 60131

We who nurse our babies have often been agreeably surprised to note that when the rest of the family comes down with a cold or flu, the baby remains free of it, or has only a mild case. Studies have shown that breastfeeding definitely prolongs the period of natural immunity to virus diseases. These include mumps, measles, polio, some kinds of pneumonia and other respiratory infections, and some diarrhea.

Many studies indicate that nursing your baby will improve your chances of avoiding breast cancer.

Won't Nursing Spoil the Shape of My Breasts?

On the contrary; if breastfeeding has any effect, it will be to improve your figure. The bugbear here is the fear of developing pendulous breasts. Proper support during pregnancy and the avoidance of obesity (both needed whether you plan to nurse or not) are all that is necessary to keep you in good shape.

★ **Happy Baby Food Grinder**

When it comes to tools for child-rearing, this item is second only to the human breast in solving feeding problems. Better than a blender, it can easily be carried wherever parents go, to grind table foods up to proper consistency for small infants through toddlers.

[Suggested and reviewed by Mrs. Ruth Rutherford]

**Happy Baby Food Grinder**

\$4.20 postpaid

from:  
Dolly Lundberg  
4036 Waterhouse Road  
Oakland, CA 94602

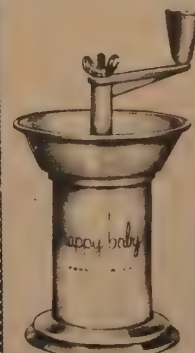

## Consumer Reports

Consumer Reports is a comfort. When the time is come to buy some goodie—color television, or a hi-fi, or a sewing machine—CU (Consumers Union) is there with the information on what's the best, or the best buy, or the healthiest of the brands available. I.e.: how not to get burned (one anticipates the CU research on brand-name psychedelics). Consumer Reports is a monthly magazine with articles on various classes of products and various cases of marketing misbehavior; the December issue is the Buying Guide—a dense compendium of all the quality/price information, available separately for \$1.95. I only wish the magazine would print ads, give the manufacturers a place to beef back, liven up the Liberal Hour.

### They're playing our song

After reading the letter in the July issue about the record that turned out to be "Howdy Doody Time" played backwards, I thought of a weird-sounding record that belongs to my sister. Like the other record, it's on the Bud-dah Records label, by Kasenetz-Katz Association, Inc. The number is 5183. The main side, "Sweeter than Sugar," sounded right. But the flip side, called "Bitter Lemon," sounded like a weird moaning. So I reversed the turntable and played "Bitter Lemon" from the center out. It was "Sweeter than Sugar."

PORT MYERS, FLA. G.M.L.

Sounds as though Kasenetz-Katz has come up with a neat way to cut down on recording expenses, but we wonder if they've considered the interesting question of royalties.

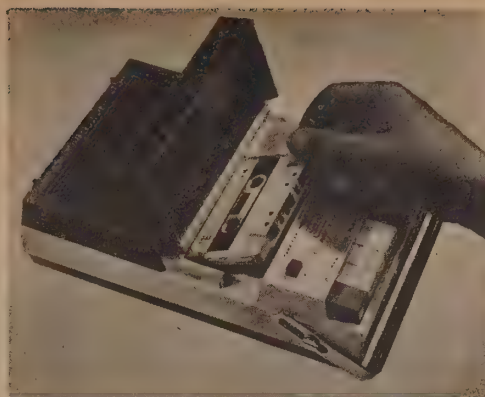

The cassette in the Sears must be pulled out; some other recorders have a convenient ejector button

### CU'S KEY FINDINGS

Cassettes look like the wave of the future in tape-recorded music. But right now the sound of cassette players (or at least of the portable models CU tested) is equivalent only to that of a good AM portable radio—pleasant casual listening. The four highest-rated models—the Sears at \$67.95 plus shipping, the Norelco at \$79.95, the Westinghouse at \$89.95 and the Ampex at \$99.90—had the best tone. For voice recording at, say, a conference, where the input will vary widely in volume, consider the Craig, \$69.95, or the Panasonic, \$59.95. Each has an automatic recording-level control that we found very effective in smoothing out variation in volume. (But beware of the Panasonic's extraordinarily short battery life.) Check any recorder before you buy for excessive flutter, or unevenness of pitch, and for a misaligned head, which can result in loss of treble tones. The full report tells you how.



The Craig (left) and the Panasonic are useful for voice recording, but beware of the unusually short battery life of the Panasonic

### Consumer Reports

\$6.00 / yr. (monthly) U.S.  
\$6.50 Canada, Latin America, Spain  
\$7.00 elsewhere

from:  
Consumers Union  
Mount Vernon, N. Y. 10550

### Consumer Reports Buying Guide

\$1.95 postpaid

from:  
Consumers Union  
Mount Vernon, N. Y. 10550

or WHOLE EARTH CATALOG

### CONSUMER REPORTS

Electric Toasters  
Cassette Tape Recorders  
Durable Press Shirts  
Freezers  
Stainless-Steel Flatware  
Champagnes  
Melamine Dinnerware  
Metronomes  
Hot Plates

For an honor & Clifton too  
We also have many other products!

## Birth Control Handbook

*Fantastic. Definitive, thorough, heads-up, loving treatment of the whole birth control picture. A book by the future for the future. There's nothing in the past like it.*

Birth Control Handbook  
McGill Students' Society  
1968, 1969; 46 pp.

individual copies **free** plus postage (10¢),  
bulk-cost price \$35 per 1,000 copies

from:  
Students' Society of McGill University  
3480 McTavish Street  
Montreal, Quebec  
CANADA

WHOLE EARTH CATALOG has individual copies for **10¢** postpaid

Conception control necessarily carries liberating potential for women.

A woman may safely engage in pleasurable sexual relations without automatically submitting to the humiliating protective-dependent relationship with a man which is ordinarily imposed. Also, a woman now has the option of bearing and socializing children—it is no longer the sole source of her sexual and social identity. Once "out of the kitchen" a woman can begin to use her mind and body towards socially productive ends by joining labor forces and professions on a level of equality with men.

Condoms can be bought from a drug store without a prescription. The most common retail price for a good brand is about 3 for \$1.25 although the price varies considerably, especially with lubricated and skin condoms.

It is common practice to keep a condom in a wallet or pocket until it is needed. This is a serious mistake. The combination of moisture and heat provided by contact with the body leads to deterioration of the condom. The sheath should never be kept in a wallet or pocket for any length of time; it is best to leave condoms in the small cardboard containers in which they are usually sold. Kept this way, without excessive heat or moisture, condoms can be stored for several months.

"Tip" condoms, or condom caps, which fit only around the glans of the penis should never be used, since they are likely to slip off after orgasm.

The diaphragm should not be inserted more than 2 hours before coitus. Also, since it takes up to 6 hours for the spermicidal preparation on the rubber dome to destroy sperm, the diaphragm must not be removed until six hours after the last ejaculation. The diaphragm may be left in place for as long as 24 hours after which it should be removed and washed with soap and water.

Although there is much disagreement among doctors as to which is the best IUD available, it seems that the Lippes loop (size D, a little more than 1 inch in diameter) is the best one. The Lippes loop is preferred because it has lower expulsion and pregnancy rates, and fewer side effects. Other advantages of the loop, which it shares with such devices as the Margulies coil include: the ease of insertion and removal, and a nylon appendage which allows the woman to check for the IUD's presence. Although sufficient research has not been done, it appears that effectiveness and acceptability of the Saf-t-coil are similar to those of the loop.

There has not been a single case reported in which an IUD caused cancer. IUDs are not the cause of any kind of cancer.



In every large Canadian or American city there is usually one, and often four or five qualified gynecologists or surgeons who are willing, for a price, to perform safe abortions (D. and C. or vacuum aspiration). Other doctors in the area, too afraid to do such operations themselves, learn of the existence of such colleagues and refer patients of their own to them. Pregnant women, looking for medical abortionists, usually find one by asking several doctors who will not perform the operation themselves to refer them to a doctor who will. Usually, after three or four attempts the woman finds one doctor who knows a qualified medical abortionist. Very often, medical students, interns or social workers working in hospital clinics are prepared to refer pregnant women to abortionists. In some cities, there are abortion referral services, such as those organized on university campuses, or a Clergymen's Council on Abortion. Doctors who regularly perform abortions are usually highly skilled. They are careful to use local anesthetics during the operation and to prescribe antibiotics and pain killers (for cramps) to be taken after the abortion.

## Snugli Baby Carrier

*This is the most useful baby carrier I have ever seen. It can be used with a day-old baby, because of the head support, as well as a 2 year old—but not simultaneously since to enlarge the pack tucks are taken out as the baby grows.*

*A Snugli provides a mother with a baby carrier that allows her to have both hands free. New mothers can attend classes, work, shop, do housework, etc. without having to find a babysitter. Needless to say babies love it. If you can't stand to live with a colicky baby, put it in this pack and fix dinner or whatever.*

*The Snugli is of extremely high quality (will bear several machine washings and dryings per week and teething; being stuffed in purses and being left in the rain.) It is very comfortable as long as the shoulder straps are kept tight so that the weight is not carried on the small of the back.*

*I recommend this as second only to diapers to prospective parents.*

[Reviewed by Mary Jane Markley,  
Suggested by Chris Brown]

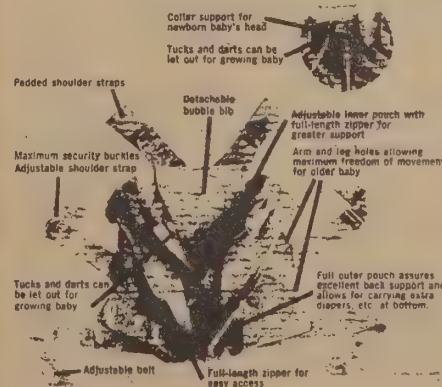

### Snugli Baby Carrier

\$28.95 postpaid from:  
Snugli  
Route 1, box 685  
Evergreen, Colorado 80439

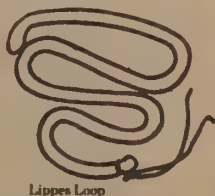

Lippes Loop



Margulies Coil



## Champagne Living on a Beer Budget

If your vision of an alternate life style includes a dome in the mountains, raising your own food and making your own clothes from homespun wool, you probably ought to pass this book up and wait til somebody writes Beer Living On A Bay-Rum Budget.

But if you are pioneering in or near a city, and if money passes through your hands with some regularity; if, that is, you consider yourself what I have come to think of as a 'suburban guerrilla,' then Champagne Living On A Beer Budget would be a handy tool to have around your camp.

(Someday, after I've lived in the suburbs longer, I'd like to write an essay about my vision of the suburban guerrilla. He's a definite phenomenon. There's a sizeable population of them here in the San Francisco Bay area, men and women out to enjoy the advantages of town life without paying the customary penalties. Every suburban guerrilla probably has his own definition of himself, but my own sense of him is this: he has a job, but not a career. He likes the comforts, but doesn't want to go into debt for them. He makes distinctions between things that are good and things that are merely expensive. He may go in for elegance, or he may dig the funky scene. Hippies, after all, are urban guerrillas. But hippies are kids mainly grooving on each other in special enclaves, and that isn't quite what I'm talking about. I'm talking about people who see the possibility of a rich and abundant adult life within the context of those same suburban communities generally condemned as such hopeless wastelands that 'real' life cannot be supported there. The suburban guerrilla I have in mind is one of the suburbs, as well as in them.

He challenges the assumption that the suburban context is hard, absolute, impenetrable, like plastic. To him, more like a piece of cheesecloth, full of holes to breathe through, and to wind in and out of, like a morning glory, or a pole bean. He borrows much of his point of view from the orientals. He realizes that life goes on in the suburbs just like every other place, even if most of the people there are too blind and deaf to see and hear it. The guerrilla lives by his wits, one day at a time. This makes him alert and alive. He has a talent for cultivating the holes in his cheesecloth. One hole might simply be the way the world is at six a.m. Another might be first-hand knowledge of all the footpaths in the neighborhood. He creates his freedom here and there and now and then, and by diligence winds up with as much as any conscious man

anywhere. His landscape is small and patterned, but there are discoveries to be made on it, discoveries that can feed his own life at the same time they are important to the culture. I know of one elderly couple that subsists almost entirely on the food they raise in their organic garden in the backyard of their home in suburban Menlo Park. As far as I'm concerned, the trip those two people are on, the life they are proving possible, is the most inspiring radical activity in all of San Francisco's radical environs).

One needn't romanticize his life as much as all that, however, to find the book we're talking about a worthwhile manual. Anybody interested in bargains ought to have it. It's loaded with facts, tips and information on good deals in all the important categories. Food, clothing, shelter, real estate, automobiles, household appliances, medical things, taxation, funerals, recreation, retirement, consumer co-ops, travel, babies, insurance, charities, and more. It's entertainingly written; yet the rhetoric never gets in the way of the information. The people who wrote it obviously want to beat the money rap as much as any of us. They also want to live well. Their book will be of considerable help to other people trying to do both, simultaneously.

[Reviewed by Gurney Norman]

**Champagne Living on a Beer Budget**  
Mike and Marilyn Ferguson  
1968; 247 pp.

**\$0.75** postpaid

from:  
G. P. Putnam's Sons  
200 Madison Avenue  
New York, N. Y. 10016

or WHOLE EARTH CATALOG

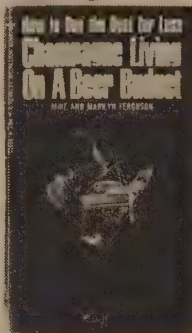
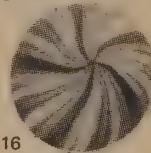

For a dollar a year, you can subscribe to Our Public Lands, a quarterly magazine telling how to buy public lands, where to hunt, fish, or camp; also details of 'Alaskan opportunities.' Order from the Superintendent of Documents, Washington, D. C. 20402

Finally we called eight establishments under Typewriters, Rental. For comparable models of a Smith-Corona electric portable, two companies wanted \$25 per month; two wanted \$22.50; three were asking \$20; one, \$15; one, \$12.50. We finally rented a nearly new machine from a firm that charged \$9 monthly on a two-month basis.

'Overexposed steaks' are a find for those who will literally look beyond the surface of things. The fluorescent lighting used in grocery store meat shelves darkens the steaks quite rapidly. Once a steak turns maroon, it's usually marked down by 25 percent or so—and it's fine.

Some expensive canned fruits, like Elberta peaches and fine Bartlett pears, can be bought in cans of 'chunks and pieces' for a fourth or less than you'd pay for canned halves.

Or, if you'd rather, the National Association of Housing Cooperatives, Inc., invites your query. Address: 465 Grand Street, New York City, N. Y. 10002. Latest information on new cooperatives would be available from the United Housing Foundation, same address; or from the Association for Middle Income Housing, 217 Park Row, New York; or the FHC Company, 322 Main, Stamford, Conn. (FHC International, 1001 15th Street NW, Washington, D.C., is an affiliate of the FHC Company and helps develop housing cooperatives overseas.)

Homes in the paths of proposed freeways have usually been bought by the city or county and are rented on an annual lease basis until time for demolition. Friends of ours are renting a \$30,000 home for \$85 a month—until the bulldozers claim it. They simply called the city switchboard and asked to speak to someone about renting city-county-owned homes.

Homes being rented are often not due for demolition for eight or ten years. They're bought up far in advance of need so there won't be last-minute snags or holdouts.

Avoid the cheap \$10-\$17 brake jobs advertised by some service stations and shops. At the price, the linings are most likely of inferior quality, and wheel cylinders won't be rebuilt.

When it comes to air travel you can avail yourself of bargains if you'll fly major airlines on weekdays, regional airlines on weekends...fly by night...forgo the two glasses of champagne in first-class quarters...buy a 'run-of-the-airline' ticket on a regional western carrier if you live in the eastern half of the country...travel to Europe in off-seasons...fly a triangle, with a stop at an intermediate glamour city thrown in for a few dollars extra...travel a heavy-volume, frequently scheduled commuter flight...forgo reservations and fly for half fare, on a standby basis, on at least one airline...or register as a first-time airline rider on another and make any round trip in the system for \$25...buy a package which wraps up hotel, entertainment, and air fare.

To locate a Memorial society in your area, or for bequeathal information, write to:

Continental Association  
39 East Van Buren Street  
Chicago, Ill. 60605

For \$1, this nonprofit organization will send you A Manual of Simple Burial (64 pages).

For 25 cents, the Continental Association will send you Memorial Associations: What They Are and How They are Organized. The association will also be happy to inform you if any societies are newly active in your area.

## Unity Buying Service

All my life I heard about factory prices, always mentioned in hushed tones or resentful tones, depending on whether one had been obtained or not. But I never saw one in person til this catalog came along, and, by god, there they are: factory prices, half or two-thirds of store prices. This catalog has slick pictures of mostly slickery items, with a truthful store prices, and then—over here in this plain jane book—the factory prices for same. You add 5%, order, wait two weeks, and here comes all right stuff, righteous cheap.

[Suggested by Muldoon Elder]

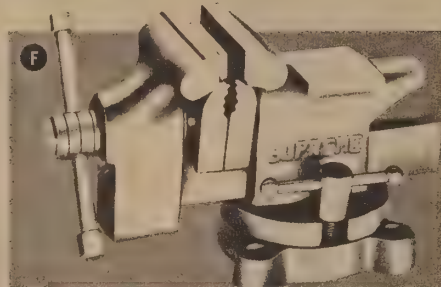

**F A HEAVY DUTY SWIVEL BASE MACHIN-IST'S VISE** Jaws 4" wide open to 3 1/2". Ship. wt. 13 lbs. Size: 9 1/4 x 5 1/4 x 5 1/4. **2417A635**

Store \$10.50 Unity \$3.98 + 5% = \$4.18

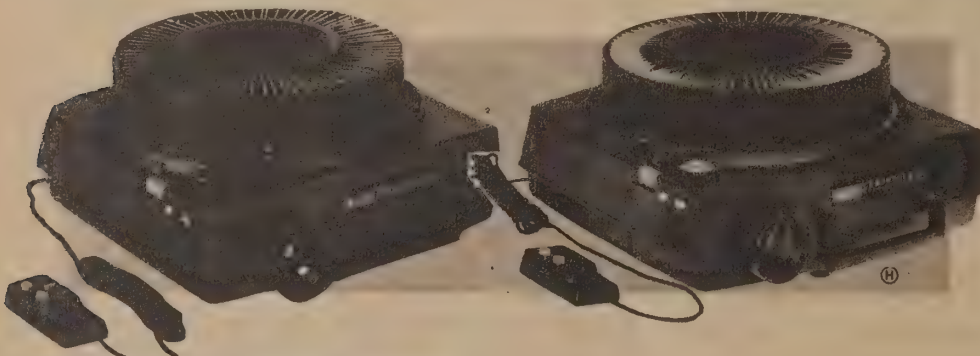

Kodak Carousels are THE standard of the image projection world. We've seen nowhere a better price than here.

**© KODAK 800 CAROUSEL PROJECTOR WITH 5" F/3.5 LENS** Has 11 basic features plus fully automatic remote slide control: focus; advance; reverse; stop slides by 12 ft. cord. Automatic slide change at 5, 8, or 15 second intervals for unattended continuous projection. Slide change, forward and reverse by buttons at projector. 4 position switch including Hi-Low brightness control. Ship. wt. 19 lbs. **3699A13270** Store \$144.50; Unity \$ 91.51 + 5% = \$96.09

SAME AS ABOVE WITH 4" TO 6" ZOOM LENS. **3698A10980** Store \$174.50; Unity \$110.51 + 5% = \$116.04

**© KODAK 850 CAROUSEL PROJECTOR WITH 5" F/2.8 LENS** Incorporates 11 basic projector features with automatic focus. Focuses slides automatically after the first slide. 3 way slide control. Remote—change, forward, reverse, stop by 12 ft. cord, push button controls at the projector and automatically at 5, 8, or 15 second intervals. Tungsten-halogen (quartz) lamp for longer life. Ship. wt. 19 lbs. **3700A14400** Store \$189.50; Unity \$120.01 + 5% = \$126.02

SAME AS ABOVE WITH 4" TO 6" ZOOM LENS. **3701A16300** Store \$214.50; Unity \$135.85 + 5% = \$142.65

**88**

- Office-size, 84-character keyboard
- Touch-Set margin controls
- Calibrated paper ball
- Rugged, all-metal construction

**Economy portable comes with your choice of Pica or Elite type styles. Convenient "console" carrying cover included. Shipping weight 11 lbs. Attractive smooth gray finish.** Store **6976A3900 Pica \$49.95** **6977A3900 Elite \$49.95** Unity **\$32.44 + 5% = \$34.06**

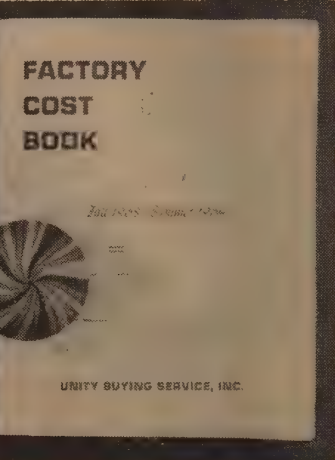

## Unity Buying Service

Annual membership **\$5.00**

for membership from:

Unity Buying Service, Inc.  
Mount Vernon, N. Y. 10551

**© DRAFTSMAN'S DRAWING SET** Deluxe mechanical drawing set is an invaluable aid for everyone: student; artist; instructor; etc. 19 professional quality tools packed in a smart leatherette case. Special straightening device on compass' and dividers. Set contains: 1-6" compass; 1-4 1/2" compass; 5/4" ruling pen; 6" Swedish detail ruling pen; 6" hairspring divider; 5" drop bow with pen and pencil parts; 3 1/4" steel spring bow pen, pencil and divider with center screw. Case size: 12 x 5 1/2 x 1". Store **6277A1650** Ship. wt. 2 lbs. **\$ 30.00**

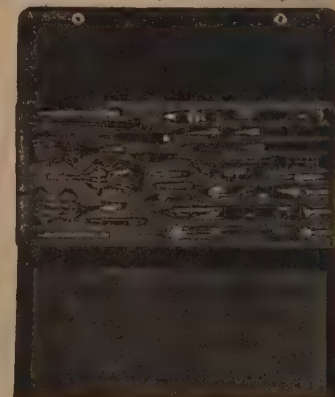

Unity **\$12.60 + 5% = \$13.23**

**Sears/Wards mail order**

If you live away from cities, where telephone calls and quick car trips aren't possible, the Sears and Wards catalogs are indispensable. Clothes, tools, building materials all via mail and service is rapid. Both catalogs are intelligently organized. Although we take such for granted, the Sears catalog was on display in the U. S. pavilion at the Brussels World's Fair and continually mobbed by people of other countries.

Both have farm catalogs, with contractor's and light industrial equipment and all types of farm equipment, including live poultry. Until last year Sears had a separate catalog for Craftsman tools; now, however, these are included in the general catalog. Most electric tools have a year's guarantee and other tools are unconditionally guaranteed. If you break a hammer handle after three years' use, they'll give you a new hammer.

Order from nearest Sears or Wards store. Two catalogs a year: spring-summer and fall-winter. Free. To stay on the mailing list you must make two orders every six months.

**Sears**

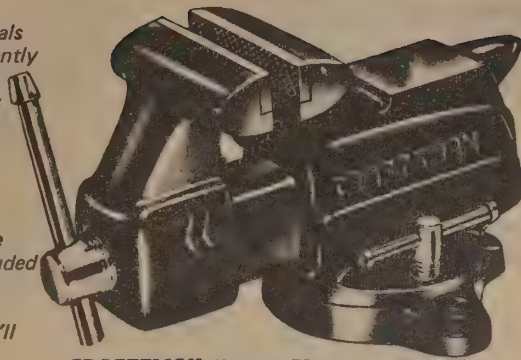

**CRAFTSMAN Bench Vises** \$13.99  
Beam encloses screw . . can't clog 3 1/2-inch jaw

Heavy-duty steel channel. Jaws can't wobble sideways or up and down. Convenient, built-in pipe jaws. Slanted swivel locking lever, angled away from vise. Vise swivels 165° and locks tight.

Screw handle tapered ends forged from handle stock . . can't come loose. Zinc-plated handle, screw, lock nut. Fast-acting, Acme-threaded steel screw seated in replaceable malleable iron nut . .

**Wards**

**6-ton standard hoist**

**84<sup>95</sup>** cash or \$5 a month

Wards low priced handyman

Full 63-in. lifting height. Has exclusive patented linkage described above. 5-qt. cylinder capacity—if tractor hydraulic reservoir is too small for capacity of cylinder, bolster hoists can be operated with either single or double action. Big 5-in. I.D. cylinder. Recommended for 10 and 12-ft. wagon boxes. Shipped same as (A) above.  
X89 FX 25901 F—Ship. wt. 220 lbs. 84.95

All wagon boxes, hoists fit Wards lo-loads, pages 50-51

Truckers' or knier rope for roping animals, tying loads, etc. Finest Manila fibers are tightly laid for durability; treated to resist moisture, mildew, severe weather. 7/8-in. diameter. Cut to order. Ship. wt. 6 lbs. per 100 ft. State length on your order.  
84 FX 9648 H-3 Strand. Per ft. 7c  
84 FX 9649 H-4 Strand. Per ft. 7 1/2c

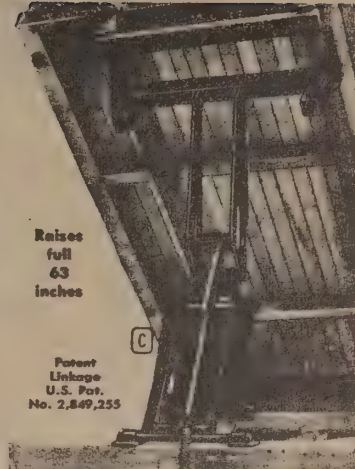

Raises full 63 inches

Patent Linkage U.S. Pat. No. 2,849,255



**Economy 6-speed blender**

6-speed blender ranges from 11,500 to 16,000 RPM. Economically and efficiently mixes drinks, purees food for baby or a special diet; also chops vegetables. 38-oz. clear plastic jar is graduated in 1/2-cups. Liffoff 1 1/2-oz. measuring cap. Convenient pouring spout. Chrome-plated base, black plastic lid. No-mar feet. Cord. Abt 12 1/2 in. high. 316 watts. Wt. 5 lbs. 4 oz.  
86 C 45818 . . . . . 19.49

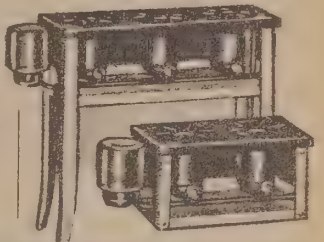

**Portable kerosene stoves in 4 models**

Sturdy steel construction with durable black and white baked enamel finish. 4-in. burners have solid brass sealed adjustable valves to regulate heat. Partially closed backs. Removable screw-end permits easy draining of fuel line. 2-qt. glass fuel bottle. 3-ply asbestos wicks. Both 3-burner stoves take full-size wash boilers.

12Dx28 1/2 in. high.  
68 C 1155AAT—Ship. wt. 24 lbs. 16.50  
2-burner high-leg stove (not shown) 27Wx12Dx28 1/2 in. high.  
68 C 1154AAT—Ship. wt. 19 lbs. 13.50  
(7) 2-burner table stove. 27 in. wide, 12 in. deep, 10 1/2 in. high.  
68C1144AT—Ship. wt. 13 lbs. 11.50  
3-burner table stove (not shown) 37Wx12Dx10 1/2 in. high.  
68 C 1145 AT—Ship. wt. 18 lbs. 14.50

3-point hitch tractor-mounted concrete mixer \$279 cash or \$14 monthly

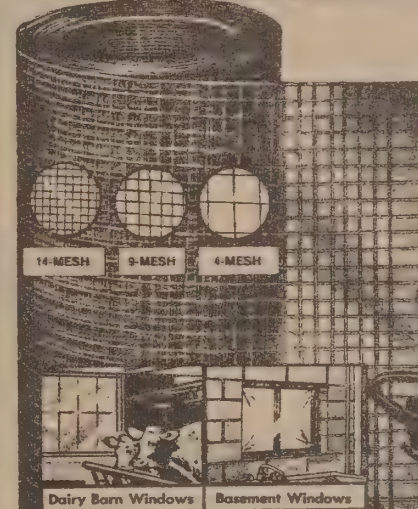

**Reinforced plastic, translucent**

—extra strong Low as 5c per sq. ft. 100 ft.

Mixes 8-cu. ft. batch—maximum cap. 1000 lbs. Like owning your own ready-mix truck, but even more versatile. Mount this 15-cu. ft. mixer on the back of your tractor, go places even a truck can't. Small enough to go through doors, into tight areas—pour after rain and in mud that would mire a truck. Fits standard 3-pt. hitch, no bolting; off in 3 minutes.

Just dial width of groove desired with **CRAFTSMAN Adjustable Dado** \$19.99



Precision-cut adjustable hub lets you dial width from 1/4 to 3/4 inch without removing dado from saw. Calibrated in 16ths of an inch. Maximum depth of cut is 2 inches. Once dado is set following cut will not vary. Use to plough, dado, lap, groove, joint and rabbet.

7-inch tempered, selected tool steel blade. 8 precision-ground carbide-tipped teeth . . bevel ground on front face for free cutting on plywood, and crosscutting on all hard and soft woods. Also use on Formica® laminated plastic, other laminates and sensitive materials. 1/2-inch arbor with 3/8-inch bushing for use on 8, 9, 10, 12 and 14-inch radial arm and bench saws.  
9 AT 3267—Shipping weight 2 lbs. 12 oz. . . . . \$19.99



**5 CRAFTSMAN Pocket Sighting Surface Level.** As a sighting level, can be used for grading, leveling, preliminary surveys. As a surface level, can be used for leveling shelves, refrigerators, counter tops and many other items. Objective window has center line plus line to determine pitch. . . stadia lines with 1:12 ratio to estimate distance. Built in sunshade. Only 5 inches long. Lightweight aluminum with steel tension clip. Instruction manual included. Plastic case.  
9 AT 4624—Shipping weight 13 ounces. . . . . \$5.79

**Our best Tool Box \$18.99**

3 Extra-heavy gauge steel body. Divided tote tray. Handle on top, both ends. Two 1-piece drawbolts. Center lock, 2 keys. Red-enamel finish. 24 1/2 in. long; 9 1/2 in. wide; 9 1/2 in. high. See the "Craftsman Commercial" story on page 8.  
99 AT 65141C—Wt. 23 lbs. . . \$18.99



**Italian Bees** . . favorites for their industriousness and low price

2-pound package with Italian Queen Low as \$7.95



A 2 or 3-pound package of bees with bred queen gets your new hive off to a good start. And just watch it grow . . in one season it's possible to multiply your original investment. Earnings from honey and beeswax can make beekeeping a profitable side line as well as a rewarding hobby.

Natural coloring of drone, queen and worker is black and yellow. Extra bees included with every package to cover natural losses in transit. From apiary in southern United States. See shipping note below. State date wanted.

2-lb. Package of Bees with one bred Italian Queen. Good choice for hobbyist. F32 KF 55441V—One Package. Postpaid. (Shipping weight 7 pounds) . . . . . \$7.95

3-lb. Package of Bees with one bred Italian Queen. Excellent producers. F32 KF 55415V—One Package. Postpaid. (Shipping weight 8 pounds) . . . . . \$9.95

F32 KF 55416V—Ten Pkgs. Postpaid. (Wt. 80 lbs.) \$8.50 monthly. Cash \$89.00

**Tri-Set® Post Anchors** Stronger support than with concrete footings, and easier to install. No holes to dig, fill or tamp.



**8-quart Fruit Press**

Presses most fruits into fresh, flavorful juices with no preservatives added

\$21.95 cash \$4 monthly

Press fruit at the peak of its flavor and can it or enjoy it right then at home. Extracts all juice with minimum waste. Even the kids have fun with this press. Patterned after the old familiar farm cider press. All wooden parts of western hardwood, specially chosen because of its moisture resistance . . you get no taste transfer that way.

Rustic natural wood finish with red metal trimming. Built to take heavy pressure. Sturdy welded cast-steel frame. Tub of hardwood stays fastened by strong iron hoops. Heavy steel crosshead and press screw with accurately cut threads.  
32 KF 80052K—Shipping weight 18 lbs. . . . \$21.95

**The Armchair Shopper's Guide**

This cheerful book is an uncommonly practical compendium of access. Listed here are all of the major and many of the minor mail order shippers in the world. To a large extent the shippers carry items not available locally. Each source is very well described and compared with its competitors. The Armchair Shopper's Guide is more general than us, and geared to wealthier readers, but if you use the WHOLE EARTH CATALOG very much, you can almost certainly use the Shopper's Guide.

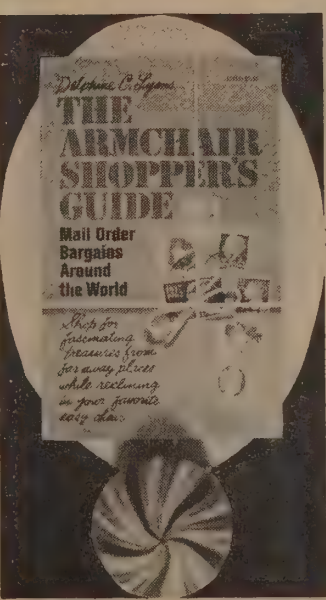

**The Armchair Shopper's Guide from:**

Delphine C. Lyons 1968; 218 pp. \$1.50 postpaid

You'll have to pay the sales tax if the mail-order house is located in your own state or municipality, but you aren't required to pay it to firms in other states, nor may they charge you their local sales taxes. Although this has always held true for most mail-order firms, in the past such big houses as Sears, Roebuck and Co. made a practice of collecting the various local sales taxes from their customers and passing them on to the state or city involved. However, a recent court ruling has declared this illegal. So, if you live in a place such as New York City you can save a pretty penny (5 percent) by buying by mail from out-of-state firms.

The Ollech and Wejs Watch Co., 8039, Zurich, Switzerland (catalog free) deals mainly in specialty watches for sportsmen and technicians. Men's watches begin at \$13 for a 17-jewel skindivers' shockproof model that has a revolving bezel for giving time in two zones simultaneously or for counting elapsed time. There's a watch that doubles as a slide rule and, most expensive of all, the 'SMT Roboter 17-jewel Pilot and Diving Chronograph,' which looks like something out of the future with its revolving bezel, telemetric scale, five-minute yacht racing calibration, and whatnot, costing \$65. (Only one style is offered for women at this house, a 17-jewel diving watch at around \$13, \$33 if you want a self-winding model.)

Pine Hills Herb Farm, P. O. Box 307, Roswell, Ga. 30075 (brochure free) also has an extensive collection of herbs, all organically grown. In addition, they put out a book for tyro herbalists which is \$1 by itself or 50¢ with an order.

Orientalia Bookshop, Inc., 11 East 12th Street, N. Y., N. Y. 10003 (catalogs free): This house specializes in books on Asia and the East, in all areas (and many languages).

Eddie Bauer, 417 East Pine St., Seattle, Wash. 98122 (catalog free): Although some items of trail equipment are available here, notably sleeping bags manufactured by the firm, clothes are the main offering. Handsomely styled casuals, as well as outfits for the serious outdoor man and woman, featuring insulated garments made in the firm's own plant, are available, as well as some festive long underwear. Hall Boot Co., P. O. Box 17246, El Paso, Texas 79917 (catalog free) has a huge selection of made-to-measure Western and English type boots, both American-made and imported, including unusual as well as traditional styles.

For used encyclopedias and other reference books, free price lists are available from The Reference Book Center, 159 West 33 St., N. Y., N. Y. 10001, and The Literary Mart, 1265 Broadway, N. Y., N. Y. 10001.

**Government Publications**

This paperback is titled **Over 2000 Free Publications**: which is sort of true, but mainly gross boosting. Skip that. The book is a good, recent, cheap compendium of information easily available from the Government—inexpensive sometimes practical sometimes trivial sometimes precisely what you need for an important task. As far as we're concerned, this \$.95 book replaces the \$12 book on Government publications we used to list.

[Suggested by Michael Rosenthal]

**Over 2000 Free Publications**

Frederic O'Hara  
1968; 352 pp.

**\$.95** postpaid

from:  
WHOLE EARTH CATALOG

**\$1.05** postpaid

from:  
The New American Library  
1301 Avenue of the Americas  
New York, N. Y. 10019



**Making Household Fabrics Flame Resistant** (rev. ed. 1963). I454. Tells how household fabrics may be made flame-resistant by treating them in the home with various flame-retardant solutions. Describes how to prepare and apply these solutions.

**The Use of Sawdust for Mulches and Soil Improvement** (1951). (Circular 891). 15¢. For sale only.

**Hepatitis** (rev. ed. 1966). PHS Publication #446.  
**Hepatitis** (1967). Unnumbered PHS fact sheet.

**Child's Self-Help Overall** (1948). L251.

**Hot Weather Comfort**, HIS-3, 5¢; \$2.25 per 100.

**Rope, Knots, and Climbing**. Catalog No. I29.26:7. 15¢. Contains useful information on important knots and hitches, rope splices, the skill of throwing a rope, rope-climbing techniques, and other related subjects.

**Wood-Frame House Construction** (1955). AH73. 65¢. For sale only. Textbook for house builder, from foundation to roof.

**Solar-Type Farm Cottage, Plan No. 7148** (1965). M1001.

**A-frame Cabins, Farm Building Plan Nos. 5964 5965** (1964). M981.

**Concrete Manual** (7th ed.—rev. reprint). \$3.25. Properties of concrete, investigation and selection of concrete materials, mixes, manufacturing, inspection, handling, placing, finishing, curing, weather precautions, concrete repair and maintenance, use of epoxy resins, special types of concrete and mortar, prestressed concrete.

**Plumbing for the Home and Farmstead** (1966). F2213.  
**Pole Building Construction, Type "B," Plan No. 5831** (1958). M750.

**Portable Shade for Hogs, Plan No. 5947** (1964). M975.

**Farmstead Sewage and Refuse Disposal** (1963). AB274. All about septic-tank systems. Discussion of other refuse-disposal methods.

**What You Should Know About Oysters, Clams and Mussels**, PHSP-1393, 5¢; \$2.50 per 100.

**Facts About Nutrition**, PHSP-917, 25¢; \$18.75 per 100.

**Conserving the Nutritive Value in Foods** (1963). G90. Effects of storage, cooking. Tips on best procedures.

**Recipes for Quantity Service** (1958). HERR5. \$2.50. For sale only. O.P. Directions for quantities for twenty-five, fifty, or one hundred portions.

**Rope on the Farm** (1966). F2130. How to splice, tie hitches and knots. Caré and use.

Day, Cyrus Lawrence. **The Art of Knotting and Splicing** (1955). 2d ed. Step-by-step photographs with accompanying descriptive text on facing pages, covering hundreds of knots, splices, bends, etc. It has 738 photographs. Bibliography and index. \$5.00.

**Government Printing Office**

O'Hara (above) doesn't begin to list all of what's available from the GPO. If you're really interested in a particular area, you might as well get the free list of publications in that area. Or you can get the free biweekly list of "Selected U. S. Government Publications." Or, for totality, for \$6, the "Monthly Catalog of U. S. Government Publications." All, all from Carper Buckley,

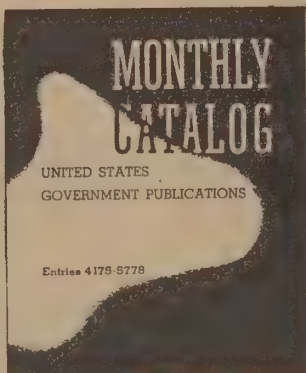

Superintendent of Documents  
U. S. Government Printing Office  
Washington, D. C. 20402

- 10. Laws, Rules, and Regulations.
- 11. Home Economics. Foods and cooking.
- 15. Geology.
- 19. Army. Field manuals and technical manuals.
- 21. Fish and Wildlife.
- 25. Transportation, Highways, Roads, and Postal Service.
- 28. Finance. National economy, accounting, insurance, securities.
- 31. Education.
- 33. Labor.
- 33A. Occupations. Professions and job descriptions.
- 35. National Parks. Historic Sites, National Monuments.
- 36. Government Periodicals and Subscription Services.
- 37. Tariff and Taxation.
- 38. Animal Industry. Farm animals, poultry, and dairying.
- 41. Insects. Worms and insects harmful to man, animals, and plants.
- 42. Irrigation, Drainage, and Water Power.
- 43. Forestry. Managing and using forest and range land, including timber and lumber, ranges and grazing, American woods.
- 44. Plants. Culture, grading, marketing, and storage of fruits, vegetables, grass, and grain.
- 46. Soils and Fertilizers. Soil surveys, erosion, conservation.
- 48. Weather, Astronomy, and Meteorology.
- 50. American History.
- 51. Health and Hygiene. Drugs and sanitation.

- 51A. Diseases. Contagious and infectious diseases, sickness, and vital statistics.
- 53. Maps. Engineering, surveying.
- 54. Political Science. Government, crime, District of Columbia.
- 55. Smithsonian Institution. National Museum, and Indians.
- 58. Mines. Explosives, fuel, gasoline, gas, petroleum, minerals.
- 59. Interstate Commerce.
- 62. Commerce. Business, patents, trademarks, and foreign trade.
- 63. Navy. Marine Corps and Coast Guard.
- 64. Scientific Tests, Standards. Mathematics, physics.

- 65. Foreign Relations of the United States. Publications relating to foreign countries.
- 67. Immigration, Naturalization, and Citizenship.
- 68. Farm Management. Foreign agriculture, rural electrification, agricultural marketing.

- 70. Census. Statistics of agriculture, business, governments, housing, manufactures, minerals, population, and maps.
- 71. Children's Bureau, and other publications relating to children and youth.
- 72. Homes. Construction, maintenance, community development.
- 78. Social Security. Industrial hazards, health and hygiene, safety for workers, pensions, workmen's compensation and insurance.
- 79. Air Force. Aviation, civil aviation, naval aviation and Federal Aviation Administration.
- 79A. Space, Missiles, the Moon, NASA, and Satellites. Space education, exploration, research, and technology.
- 81. Posters and Charts.
- 82. Radio and Electricity. Electronics, radar, and communications.
- 83. Library of Congress.
- 84. Atomic Energy and Civil Defense.
- 85. Defense. Veterans' affairs.
- 86. Consumer Information. Family finances, appliances, recreation, gardening, health and safety, food, house and home, child care, and clothing and fabrics.
- 87. States and Territories of the United States and Their Resources. Including beautification, public buildings and lands, and recreational resources.



**Federal Domestic Assistance**

The Catalog is a guide to Federal programs. It describes the purpose, eligibility requirements for an incredible variety of aids, along with the 'how-to-apply.'

I recommend it as a wishbook and as a tool. For the surprise is that many of the aids exactly fit the needs of the new communities (loans for home industries, for example, pp 27-28) and are specifically open to non-profit groups or low-income persons. Urban groups will find similar luck, I think, in linking their goals to an existing program.

The catalog has no cost. It can be requested from your Congressman/Senator or the Public Information Office in the Office of Economic Opportunity, HUD or HEW.

[Suggested and reviewed by Richard R. Reed]

Catalog of Federal Domestic Assistance 1969; 619 pp.

free from: OEO Regional Offices

72 West 45 Street New York, N. Y. 10036 (Conn., Me., Mass., N.H., N. J., N. Y., P.R., R.I., Vt., Virgin Islands)

Marsh Bldg. 1832 M Street NW Washington, D.C. 20506 (Del., D.C., Ky., Md., N.C., Pa., Va., W.Va.)

730 Peachtree Street, NE Atlanta, GA 30308 (Ala., Fla., Ga., Miss., S.C., Tenn.)

623 So. Wabash Ave. Chicago, Ill. 60605 (Ill., Ind., Mich., Minn., Ohio, Wisc.)

Lowich Bldg. 314 W. 11 Street Austin, Tex. 78701 (Ark., La., N.M., Okla., Tex.)

911 Walnut Street Kansas City, Mo. 64106 (Colo., Idaho, Iowa, Kan., Mo., Mont., Neb., N.D., S. D., Utah, Wyo.)

100 McAllister Street San Francisco, CA 94102 (Alaska, American Samoa, Ariz., Calif., Guam, Hawaii, Nev., Ore., Wash., Trusts)

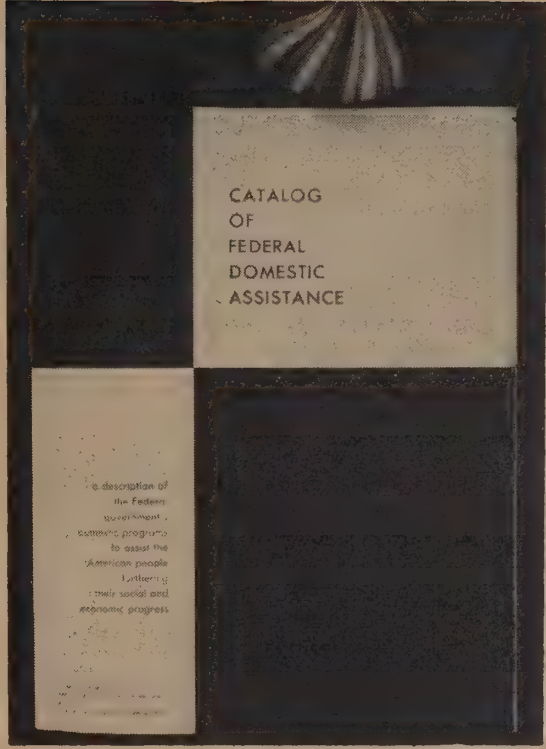

PROGRAM TITLE	ECONOMIC OPPORTUNITY LOANS TO COOPERATIVES	POPULAR NAME
Nature and Purpose of Program	This program provides 30-year, 4 1/4 percent loans to cooperatives that furnish essential processing, purchasing, or marketing services, supplies, or facilities to low-income rural families. It also provides technical assistance in establishing, operating, and managing cooperatives.  The loan may be used to: 1. Process products grown on members' farms 2. Assemble, market, and transport home-produced goods 3. Purchase and make available to members essential machinery and equipment for the production of goods and services 4. Provide services to market agricultural products 5. Purchase and make available to members farm operating and home industry items 6. Purchase land and buildings to carry out processing, purchasing, and marketing services 7. Pay costs of organizing cooperative associations 8. Refinance certain debts.	
Who Can Apply and How To Apply	Cooperatives may be eligible if (1) two-thirds of the members are from low-income rural families living in areas where the population is under 5,500; (2) they are unable to obtain credit on rates and terms they can meet; and (3) the services to be supplied are not otherwise being adequately provided in the community.  Applications are made at local county offices of the Farmers Home Administration.	

library resources . . . . .	104	Commodity distribution . . . . .	13	Community renewal program . . . . .	321
work-study programs . . . . .	105	Communications . . . . .		Community service and continuing education . . . . .	106
Commerce . . . . .		allocation of broadcast frequencies . . . . .	448	Comparative education services . . . . .	161
business assistance, services, and information . . . . .	68	common carrier services regulation . . . . .	448	death, veterans . . . . .	547
business intelligence . . . . .	60, 63, 68, 85	information services . . . . .	448	dependent parents of veterans . . . . .	547
census and statistical reports . . . . .	64	investigation of complaints . . . . .	448	indemnity, veterans' dependents . . . . .	528
census mapping and statistical areas . . . . .	65	regulatory activities . . . . .	448	service-connected disability, veterans . . . . .	548
census special tabulations and services . . . . .	66	telephone rates . . . . .	448	veterans' dependents . . . . .	547
commercial intelligence . . . . .	60, 63, 68	Communities . . . . .		widows, veterans' . . . . .	547
economic development, distressed areas . . . . .	70	assistance to Spanish-surnamed . . . . .	463	Comprehensive health planning grants to States . . . . .	194
economic development, loans to businesses . . . . .	72	continuing education . . . . .	106	training, studies, and demonstrations . . . . .	195
economic development, public works . . . . .	71	civil defense, shelter plans . . . . .	89	Computer activities in education and research . . . . .	476
economic development, technical assistance . . . . .	73	demolition grants . . . . .	322	Computer, development of uses . . . . .	476
export licensing service . . . . .	60	development grants . . . . .	332	Computer science . . . . .	476
export trade promotion . . . . .	61	economic adjustment . . . . .	96	research in . . . . .	476
foreign investment development . . . . .	62	emergency health activities . . . . .	197	special projects program . . . . .	476
geodetic control surveys . . . . .	74	human resources development planning . . . . .	166	student and teacher training program . . . . .	476
importation of duty-free educational and scientific materials . . . . .	69	mental health centers . . . . .	192	Conservation . . . . .	
international commercial information . . . . .	68	mental retardation facilities . . . . .	256	anadromous fish resources . . . . .	337
maritime development and promotion . . . . .	77	open space grants . . . . .	281	Appalachian region . . . . .	6
maritime manpower training . . . . .	78	physical fitness programs . . . . .	504	Federal surplus real property . . . . .	435
measures and analyses of economy . . . . .	85	renewal program . . . . .	321	flood plain management services . . . . .	92
nautical charts . . . . .	74	services to aging, grants . . . . .	237	flood prevention . . . . .	58, 92
		water and sewer grants . . . . .	279, 333		
		workable improvement program . . . . .	317		
		Community Action Program . . . . .	491		
		Head Start . . . . .	493		
		legal services . . . . .	493		
		neighborhood facilities grants . . . . .	327		
		neighborhood health centers . . . . .	487		
		Community development federal land for . . . . .	328		

PROGRAM TITLE	MORTGAGE INSURANCE FOR EXPERIMENTAL HOUSING	POPULAR NAME
Nature and Purpose of Program	This program provides mortgage insurance on individual homes and multifamily properties that incorporate new or untried construction concepts intended to reduce housing costs, raise living standards, and improve neighborhood design.  It is designed to speed the development of new concepts by reducing the risks involved in underwriting mortgages on housing incorporating experimental materials, designs and techniques	
Who Can Apply and How To Apply	Interested sponsors able to prove that the property which is proposed is an acceptable risk for testing advance housing design or experimental property standards are eligible.	
For Information Contact	Application is made through a commercial lending institution approved by the FHA as an eligible mortgagee to the local insuring office.  Federal Housing Administration or -Local FHA Insuring Office Department of Housing and Urban Development Washington, D.C. 20410  FHA's Experimental Housing Program, HUD IP-30	
Authorizing Legislation	12 U.S.C. 1715x, National Housing Act, Sec. 233, as added by the Housing Act of 1961, Sec 103, Public Law 87-70, 75 Stat. 149, 158	
Administering Agency	Federal Housing Administration Department of Housing and Urban Development	

PROGRAM TITLE	MORTGAGE INSURANCE FOR LOW AND MODERATE INCOME HOUSING—MARKET RATE	POPULAR NAME
		231 MR

**Surplus Defense Supply**

Surplus stores are a handy source of general purpose stuff. Even more economical is buying the stuff straight from Uncle: The Defense Surplus Sales Offices scattered hither and yon through the U.S. and world. Whatever you pay at the downtown surplus stores, you can expect to pay considerably less buying where they buy. Also you can bid on large fantasy items: a mile of cable, a dump truck, a landing craft, one lot assorted propellers, etc.

[Suggested by Alan Kalker]

Pamphlet How to Buy Surplus Personal Property

\$0.20 postpaid

from: GPO bookstores

**ADDRESSES OF SALES OFFICES  
DEFENSE SURPLUS SALES OFFICES  
AND GEOGRAPHICAL AREAS SERVICED**

Mailing Address	Location
11. Defense Surplus Sales Office P.O. Box 8019, 30th Building 652, U.S. Naval Street P.O. Base Philadelphia, Pa. Philadelphia, Pa. 19101	
16. Defense Surplus Sales Office P.O. Box 660 Building #115 Newport, R. I. 02840 Naval Base, Gate 51 Portsmouth, R. I.	
18. Defense Surplus Sales Office P.O. Drawer 1 830 Third Avenue— Bush Terminal Sta.- 7th Floor tion Brooklyn, N.Y. Brooklyn, N.Y. 11232	

- 21. Defense Surplus Sales Office  
P.O. Box 644 Atlanta Army Depot  
Forest Park, Ga. Building 906  
30050 Forest Park, Ga.
- 23. Defense Surplus Sales Office  
P.O. Box 31261 Building 450  
Jacksonville, Fla. U.S. Naval Air Station  
32230 Jacksonville, Fla.
- 25. Defense Surplus Sales Office  
Bldg. SDA-224, Naval Supply Center  
South Annex Building SDA-224,  
Hampton Roads South Annex  
Branch Post Office Norfolk, Va.  
Norfolk, Va. 23511

Sample prices in Oakland:

Solid picnic table: \$5	Soft arm chair: \$2
Propane field kitchen: \$30	Plate glass 3 ft x 4 ft: \$2
Office arm chairs: \$3	Step ladder: \$2
Secretary chair: \$3	Foam rubber mattress: \$2.50
Wheel Chair, wood: \$15	Fatigue shirts: \$0.45
Wood desks: \$10	Overcoats: \$3
	Wool pants: \$2
	Parachute harness: \$2.50

TRACTOR SCOOP LOADER: 2 1/4 Yard, 1959, Hough Model H-90-D, Chassis 27 AC-1381, Tire size 1600 x 24, Cummins 6 cylinder diesel engine. Backhoe Model WRH90-R. USN 45-01137. Outside Bldg. 127 - Used - Fair Condition - Repairs Required.



27. Defense Surplus Sales Office  
P.O. Box 13110 Building 27, Section 6  
Columbus, Ohio Defense Construction  
43213 Supply Center  
Columbus, Ohio

37. Defense Surplus Sales Office  
P.O. Box 6297 Corner Felix &  
Fort Worth, Texas Hemphill Sts.  
76115 Building 2  
Fort Worth, Texas

41. Defense Surplus Sales Office  
P.O. Box 58 Building 2A  
Defense Depot Defense Depot Ogden  
Ogden Station Ogden, Utah  
Ogden, Utah 84401

44. Defense Surplus Sales Office  
P.O. Box 4000 Naval Supply Center  
Bayshore Station Building 502  
Oakland, Calif. Oakland, Calif.  
94623

46. Defense Surplus Sales Office  
937 N. Harbor Drive 937 N. Harbor Drive  
San Diego, Calif. (Bldg. 1, 2nd Floor)  
92132 San Diego, Calif.

49. Defense Surplus Sales Office  
P.O. Box 15035 Building 7713  
Tucson, Ariz. 85708 Davis-Monthan AFB,  
Ariz.

- OTHER SALES OFFICES**
- Alaska**  
(Anchorage)  
Redistribution and Marketing Activity  
Elmendorf Air Force Base  
Anchorage, Alaska  
APO Seattle 98742
  - (Kodiak)  
Commanding Officer  
U.S. Naval Station  
FPO Seattle 98790
  - Bermuda**  
Redistribution and Marketing Activity  
Kindley Air Force Base  
St. George, Bermuda  
APO New York 09856
  - Canada**  
Crown Assets Disposal Corporation (CADC)  
219 Argyle Avenue  
Ottawa 2, Ontario, Canada
  - (Argentia, Newfoundland)  
Commanding Officer  
U.S. Naval Station  
FPO New York 09597

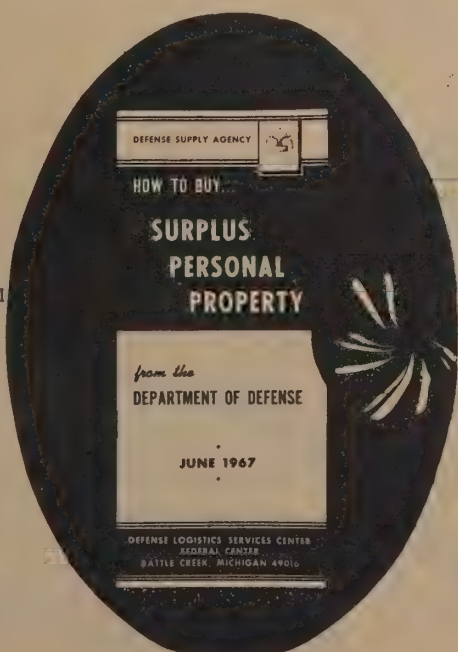

**PLANNING AND CITIES**

**VILLAGE PLANNING IN THE PRIMITIVE WORLD**

DOUGLAS FRASER



**Village Planning in the Primitive World**

Successful small community design must fit the local physical environment and at the same time render clear the community's social system and its religious system. This book has 78 pictures and eight detailed written accounts of village systems that have worked for bushmen, Cheyenne Indians, Trobriand Islanders, the Yoruba, Mbuti pygmies, and others. The systems are diverse, compelling, and mind-opening for approaching the design of one's own community.

Authority in the Bushman band rests with a headman who is responsible for controlling food and water resources. Headmanship involves no special regalia, titles, military or juridical power, and the headman receives no particular rewards; the job is inherited by the previous headman's eldest son, unless the latter chooses to renounce it by moving to another band. The principal task of the headman, apart from that of controller of natural resources, is the choosing of the site for a new settlement and the kindling of the ceremonial fire there. If he is too young, too weak, or too old to exercise office, the actual role of leadership may devolve on another man of demonstrated ability. The headman of a Bushman band is therefore only first among equals, and in many ways his function is merely that of inventory-keeper in an area where the miscalculation of resources is tantamount to disaster.



The Nias village plan is not merely modeled on the cosmos; it has all the symbolic attributes of the world. For example, the stone stairways leading to the village are carved with images of crocodiles, lizards, and other symbols of the lower world, some of them devouring fish, dogs, and other animals. This end of the village (jou) is regarded as 'downstream,' which is synonymous with death, commoners, aquatic animals, 'west' and 'north.' Sibalo, or river source, upstream, corresponds to life, chieftainship, aerial creatures, 'east,' 'south,' and the sun. The village axis is further conceived of as the sky-river, or world axis, which runs between upper world and underworld. This sky-river is both the cosmos and the world snake (i.e., the Milky Way) that rings the world (or village). The world tree grows at the center of the 'universe,' the Fuso Newali, at which spot the fusion of opposing forces is believed to take place. Such joinings or reconciliations characterize the climactic moments in Nias thought.

Another Cheyenne ceremony of comparable significance was the Sun Dance, which was known throughout the Plains. The purpose of this rite was world renewal. During the ceremonies the priest symbolically recreated the five worlds of the Cheyenne cosmology, beginning with a barren earth which has to be stocked successively with water, vegetation, buffalo, and healthy, happy Cheyenne. Another ritual, the Animal Dance, followed a similar pattern, although during it there was much clowning and good fun. These ceremonies were not necessarily given annually but depended on the presence of an individual who pledged himself (particularly when he or a relative faced death) to undertake the responsibilities of sponsoring a particular rite.

**Village Planning in the Primitive World**

Douglas Fraser  
1968; 128 pp.

\$5.95 postpaid

from:  
George Braziller  
One Park Avenue  
New York, N. Y. 10016

or WHOLE EARTH CATALOG

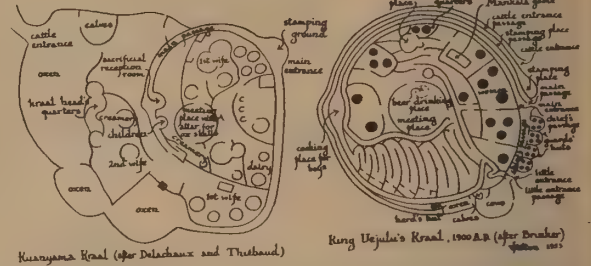
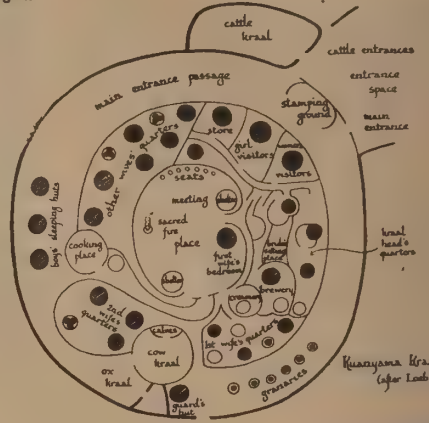

**Kibbutz: Venture in Utopia**

This book is a straightforward description of one Kibbutz. It is the history, the problems, and the moral codes of a community which began in 1920 and has grown steadily since that time. Over a span of several generations it has grappled with problems, both economic and social, which are similar to problems faced by the community movement in the United States today.

The book examines critically and sympathetically the issues of poverty, marriage, education, comfort, and communication as it has been dealt with over the various periods of this Kibbutz.

While the book is of limited practical value as a how-to-do-it text, it offers a long term perspective on the difficulties and advantages of the community way of life.

[Reviewed by James Fadiman]

**Kibbutz: Venture in Utopia**

Melford E. Spiro  
1956, 1963; 266 pp.

\$2.25 postpaid

from:  
Schocken Books, Inc.  
67 Park Avenue  
New York, N. Y. 10016

or WHOLE EARTH CATALOG



This is a community which was founded, for the most part, by middle-class intellectuals who deliberately chose to be workers. . . . Instead of aspiring to "rise" in the social ladder, they aspired to "descend." . . . This Tolstoyan attitude toward work could be evolved, it is not hazardous to say, only by romantic, urban intellectuals.

But this emphasis on youth and on the equality that exists between the young and the old create a potentiality for a condition of inequality—an inequality in which the young assume the superior, and the old the inferior, status.

Instead of cooking and sewing and baking and cleaning and laundering and caring for children, the woman in Kiryat Yedidim cooks OR sews OR launders OR takes care of children for eight hours a day. She has become a specialist in one aspect of housekeeping. But this new housekeeping is more boring and less rewarding than the traditional type.

The kibbutz, it will be remembered, was originally conceived as a means to an end—the creation of the new man. Instead of the selfish, aggressive personality created by urban capitalism, there would emerge, as a result of the new social order, a kindly, altruistic personality. This end has not been achieved.

**The Office: a facility based on change**

Nobody involved in this book is an architect, which is pretty interesting, because most of its implications are architectural. The design principles here apply splendidly to any work or living area which traffics in information or human interaction, from offices to small communities. It's a fine presentation of new theory, and Herman Miller, Inc. now has a line of office hardware behind it. We bought the book and hammered our own furniture out of scrap doors and 2x4's.

[Suggested by Dave Evans]

**The Office: a facility based on change**

Robert Propst  
1968; 71pp.

\$8.00 postpaid from:  
Taplinger Publishing Co., Inc.  
29 East Tenth Street  
New York, N. Y. 10003

or WHOLE EARTH CATALOG

Face to face across a surface maintains formality and a tone of discretion. Ninety degree location, the most natural of all conversational positions, encourages exchange. Side by side positioning allows joint viewing of papers or objects intelligibly.

The most serious health problem in offices is its sedentary nature. Compelled by lack of choice, we are forced to conduct most office activity in a sitting position. The result, as medical studies and insurance data make clear, is a steady decline in vitality, energy and general body tone.

Of even greater significance is the importance of sight as a window to mental recall. An office with no relevant visual display deprives the human performer of a spectacular recall tool: the human eye as a receptor for the mind.

For free copy, write on letterhead stationery to:

Herman Miller, Inc.  
Zeeland, Michigan 49464

Say you saw their ad in Fortune magazine.



Three sides with a slightly widened opening appears to be the best enclosure of all as a generality. There is good definition of territory or domae . . . privacy is well expressed and the ability to survey or participate is well maintained.

The management of symbolic representation of reality is the function of offices.

The office in its short evolution has adopted every kind of communication abstraction. Resultantly, we are concerned with reality simulation.



★ Atlas Shrugged

Boy I'm fond of this book. It's the only fiction alive that lets you identify with glee on the industrial, Earth-moving level of action—Fuller's domain. It's the grandest drop-out fantasy ever: the cream of civilization sense that they're being used against themselves, so they split and build a dandy mountain community to hide in. It's got big fat plot and idealistic romantic characters and mean philosophy. Ayn Rand spits on altruism and mysticism, which is kind of a relief after all the mystical goo that's going down these days. Her ethic is interesting: Thou shalt not use force, nor assume that you know what's good for somebody else. There's lots of literary flaws in this huge weird book, and lots of peculiar insights obtainable nowhere else.

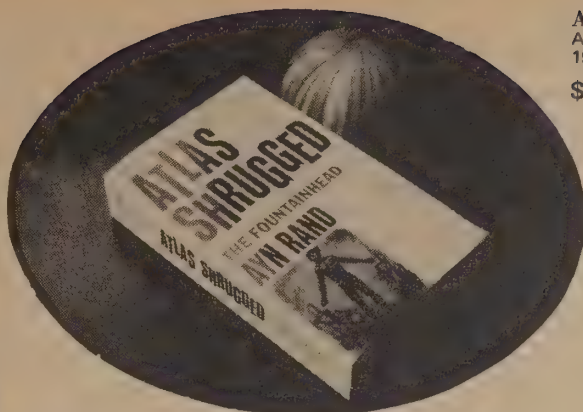

Atlas Shrugged  
Ayn Rand  
1957; 1084 pp.  
\$1.50 postpaid

from:  
New American Library  
1301 Avenue of the Americas  
New York, N. Y. 10019  
or WHOLE EARTH CATALOG

"Every man builds his world in his own image," he said. "He has the power to choose, but no power to escape the necessity of choice. . . ."

"... Now that you know the truth about your world, stop supporting your own destroyers. The evil of the world is made possible by nothing but the sanction you give it. Withdraw your sanction. Withdraw your support. Do not try to live on your enemies' terms or to win at a game where they're setting the rules. Do not seek the favor of those who enslaved you, do not beg for alms from those who have robbed you, be it subsidies, loans or jobs, do not join their team to recoup what they've taken by helping them rob your neighbors. . . ."

"If you find a chance to vanish into some wilderness out of their reach, do so, but not to exist as a bandit or to create a gang competing with their racket; build a productive life of your own with those who accept your moral code and are willing to struggle for a human existence. You have no chance to win on the Morality of Death or by the code of faith and force; raise a standard to which the honest will repair: the standard of Life and Reason. . . ."

★ The Effective Executive

Wherever there's a bunch of people doing something, somebody is bearing executive relation to the group, usually badly, so that he's unhappy and the group is unhappy, and nothing much is going on besides frustration. But some leaders are good, and with them a lot happens and everybody feels good. This book takes a deep look into how "good" executives behave in common. The generalizations that emerge are useful to anybody with responsibility, from the honcho of a commune to the goddam Pope.

"Did you really think that we want those laws to be observed?" said Dr. Ferris. "We want them broken. You'd better get it straight that it's not a bunch of boy scouts you're up against—then you'll know that this is not the age for beautiful gestures. We're after power and we mean it. You fellows were pikers, but we know the real trick, and you'd better get wise to it. There's no way to rule innocent men. The only power any government has is the power to crack down on criminals. Well, when there aren't enough criminals, one makes them. One declares so many things to be a crime that it becomes impossible for men to live without breaking laws. Who wants a nation of law-abiding citizens? What's there in that for anyone? But just pass the kind of laws that can neither be observed nor enforced nor objectively interpreted—and you create a nation of law-breakers—and then you cash in on guilt. Now that's the system, Mr. Rearden, that's the game, and once you understand it, you'll be much easier to deal with."

The least-known of the great American business builders, Theodore Vail, was perhaps the most effective decision-maker in U. S. business history. As president of the Bell Telephone System from just before 1910 till the mid-twenties, Vail built the organization into the largest private business in the world and into one of the most prosperous growth companies.

That the telephone system is privately owned is taken for granted in the United States. But the part of the North American continent that the Bell System serves (the United States and the two most populous Canadian provinces, Quebec and Ontario) is the only developed area in the world in which telecommunications are not owned by the government. The Bell System is also the only public utility that has shown itself capable of risk-taking leadership and rapid growth, even though it has a monopoly in a vital area and has achieved saturation of its original market. . . .

"Our business is service" became the Bell commitment as soon as Vail took over. At the time, shortly after the turn of the century, this was heresy. But Vail was not content to preach that it was the business of the company to give service, and that it was the job of management to make service possible and profitable. He saw to it that the yardsticks throughout the system by which managers and their operations were judged, measured service fulfillment rather than profit performance. Managers are responsible for service results. It is then the job of top management to organize and finance the company so as to make the best service also result in optimal financial rewards. . . .

Vail's third decision led to the establishment of one of the most successful scientific laboratories in industry, the Bell Laboratories. Again, Vail started out with the need to make a private monopoly viable. Only this time he asked: "How can one make such a monopoly truly competitive?" Obviously it was not subject to the normal competition from another supplier who offers the purchaser the same product or one supplying the same want. And yet without competition such a monopoly would rapidly become rigid and incapable of growth and change.

But even in a monopoly, Vail concluded, one can organize the future to compete with the present. In a technical industry such as telecommunications, the future lies in better and different technologies. The Bell Laboratories which grew out of this insight were by no means the first industrial laboratory, not even in the United States. But it was the first industrial research institution that was deliberately designed to make the present obsolete, no matter how profitable and efficient.

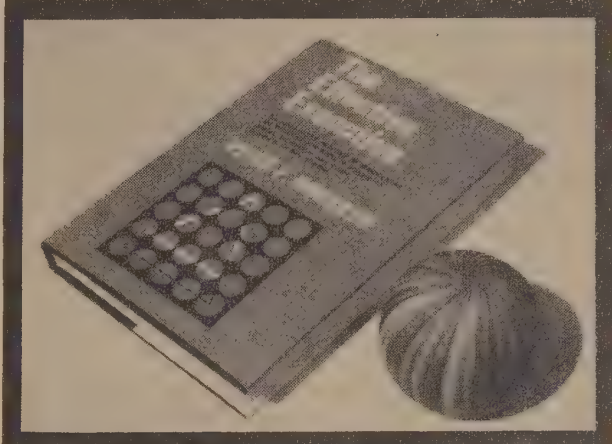

The Effective Executive  
Peter F. Drucker  
1966; 178 pp.  
\$4.95 postpaid

from:  
Harper & Row  
49 East 33rd Street  
New York, N. Y. 10016

or WHOLE EARTH CATALOG

To tolerate diversity, relationships must be task-focused rather than personality-focused. Achievement must be measured against objective criteria of contribution and performance. This is possible, however, only if jobs are defined and structured impersonally. Otherwise the accent will be on "Who is right?" rather than on "What is right?" In no time, personnel decisions will be made on "Do I like this fellow?" or "Will he be acceptable?" rather than by asking "Is he the man most likely to do an outstanding job?"

In every area of effectiveness within an organization, one feeds the opportunities and starves the problems.

No one has much difficulty getting rid of the total failures. They liquidate themselves. Yesterday's successes, however, always linger on long beyond their productive life.

There is serious need for a new principle of effective administration under which every act, every agency, and every program of government is conceived as temporary and as expiring automatically after a fixed number of years—maybe ten—unless specifically prolonged by new legislation following careful outside study of the program, its results and its contributions.

One hires new people to expand on already established and smoothly running activity. But one starts something new with people of tested and proven strength, that is, with veterans.

The effective decision-maker, therefore, organizes disagreement. This protects him against being taken in by the plausible but false or incomplete. It gives him the alternatives so that he can choose and make a decision, but also so that he is not lost in the fog when his decision proves deficient or wrong in execution. And it forces the imagination—his own and that of his associates.

REFUSAL TO SUBMIT TO INDUCTION

The conscientious objector who is under orders of induction, but who will follow his original conscientious scruples and will refuse to obey that order, must decide at what point he will draw the line. If he draws it too soon, he will lose the possibilities which exist for him to get a judicial review of his classification in the courts (see below); thus, it is almost certain that if he fails to appear at all when ordered for induction the courts will refuse to review his classification, no matter how arbitrary, unjust, or illegal it may be, on the grounds that he has not exhausted his administrative remedies. But, if he reports and goes too far, and submits to induction, then he is in the Army and subject to military law.

A registrant who has failed to report for induction, or who has reported but refused to submit to induction, will be reported by his local board as a delinquent to the United States Attorney. Arrest may follow immediately; usually, a period of from three weeks to three or more months elapses between violation and arrest.

The opinions on the law which follow are for the general information of C.O.'s, and are not intended as a substitute for legal counsel.

1. Effective executives know where their time goes. They work systematically at managing the little of their time that can be brought under their control.
2. Effective executives focus on outward contribution. They gear their efforts to results rather than to work. They start out with the question, "What results are expected of me?" rather than with the work to be done, let alone with its techniques and tools.
3. Effective executives build on strengths—their own strengths, the strengths of their superiors, colleagues, and subordinates; and on the strengths in the situation, that is, on what they can do. They do not build on weakness. They do not start out with the things they cannot do.
4. Effective executives concentrate on the few major areas where superior performance will produce outstanding results. They force themselves to set priorities and stay with their priority decisions. They know that they have no choice but to do first things first—and second things not at all. The alternative is to get nothing done.
5. Effective executives, finally, make effective decisions. They know that this is, above all, a matter of system—of the right steps in the right sequence. They know that an effective decision is always a judgment based on "dissenting opinions" rather than on "consensus on the facts." And they know that to make many decisions fast means to make the wrong decisions. What is needed are few, but fundamental, decisions. What is needed is the right strategy rather than razzle-dazzle tactics.

These are the elements of executive effectiveness—and these are the subjects of this book.

The definition of a "routine" is that it makes unskilled people without judgment capable of doing what it took near-genius to do before; for a routine puts down in systematic, step-by-step form what a very able man learned in surmounting yesterday's crisis.

We know very little about self-development. But we do know one thing: People in general, and knowledge workers in particular, grow according to the demands they make on themselves. They grow according to what they consider to be achievement and attainment. If they demand little of themselves, they will remain stunted. If they demand a good deal of themselves, they will grow to giant stature—without any more effort than is expended by the nonachievers.

★ Handbook for Conscientious Objectors

The most comprehensive and authoritative single guide to the legal requirements and procedures for C. O.s under the present draft law. This book does not advise you to become a conscientious objector, but it does help in thinking through your beliefs and realistically making a decision about the draft.

If you are considering asking your draft board for conscientious objector status, considering resistance, or just exploring your alternatives with the draft, this book is valuable. It also has information for C.O.s in the military, and describes the possible eventualities of court and prison.

CCCO also provides counseling, legal advice, help with bail, and publishes information useful to counseling agencies, lawyers and objectors. CCCO is non-church related, and lives on voluntary contributions.

[Reviewed by Fred Richardson. Suggested by many.]

Handbook for Conscientious Objectors  
Edited by Arlo Tatum  
110 pp.; Updated frequently.

\$1.00 postpaid  
\$4.00 for five, postpaid

from:  
Central Committee for Conscientious Objectors  
2016 Walnut Street  
Philadelphia, Pa. 10103

or the west coast office:  
437 Market Street  
San Francisco, CA 94105

- (1) Keep copies of everything sent to your local board; keep everything received from the local board.
- (2) Make all requests, appeals, etc., in writing. Protect yourself further by mailing them by certified letter, return receipt requested. Keep receipts.
- (3) Accept no oral promises from draft board clerks or members. Follow the printed instructions on forms and notices explicitly; or secure competent counsel if you do not understand the instructions, or if you cannot conscientiously follow them.

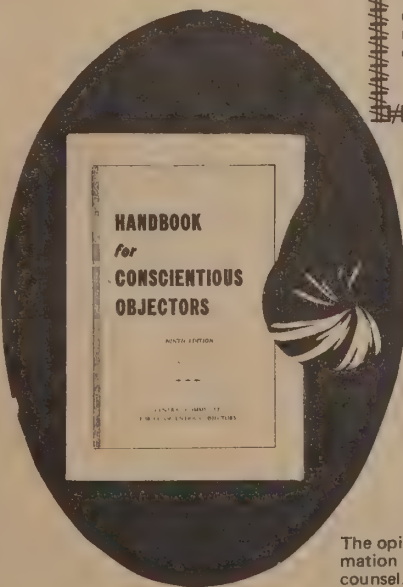

**\* How to Live on Nothing**

This book has a lot in common with *Champagne Living On A Beer Budget* (p. 88), but there's enough difference between the two to make them more companion pieces than competitors. The emphasis in *Champagne Living* is on the cheap accumulation of necessary things. *How To Live On Nothing* covers some of that ground too, but its main concern is the development of personal skills to help you get free of the need to pay people like carpenters, plumbers, doctors and real estate agents to live your practical (that is to say, your "real" or "concrete") life for you.

Of course there's no such thing as "living on nothing." The book would be more properly titled, *Living for Something*. For in a curious, unintended, Zen sort of way, that's what this book is about: living simply to establish familiarity with the details of your world, with ordinary local mysteries and miracles such as the wiring system in your house, the fabric of the garments you wear, the truth of the food you eat, and the fuel you burn. Behind the information, the advice the hints, and the facts, this book is about coming to see things as they are, through your own eyes, instead of the hired eyes of some expert or other. It's about training yourself to trust yourself, and trusting yourself to train yourself, until you're able to claim your right as a human to be competent with your hands.

Finally no one is ever competent with his hands until he uses them, and flipping through how-to-do-it books can hardly be described as manual labor. So perhaps the best way to recommend a book like this is to call it literature and emphasize its inspirational value. I kind of like that idea. I've thought the same thing about the *Whole Earth Catalog* in general, which brings up an interesting question: if the ultimate test of a good manual is its success as art, does that mean that the ultimate test of a good novel is its uses as a manual? We'll see. Meanwhile, here's a good 75 cent how-to-do-it book that could be a help to you on your next trip, real or imagined, into the New Wilderness.

[Suggested by Jim Martin. Reviewed by Gurney Norman]

If you're mathematical-minded, remember that when the smallest-sized egg is less than 85 per cent of the price of the next size, the smaller is the better buy. Brown eggs and white have the same food value, so buy the cheaper. If you live near the source of the supply, get cracked eggs at a fraction of the other eggs' cost. You can boil even cracked eggs by wrapping them individually in waxed paper and twisting the ends of the paper securely. Eggs keep best under refrigeration, stored in a covered egg box with the large end of the egg uppermost. Eggs are so versatile that they can be the basis of your breakfast, the mainstay of your everyday meals, or the proudest company fare in the form of soufflés.

A food and nutrition chapter would not be complete without mention of a food bargain that is unknown to most of us. It is MPF, the Multi-Purpose Food, developed at the California Institute of Technology and merchandised through the Meals for Millions Foundation Incorporated, 115 West Seventh Street, Los Angeles, California 90014. This is a non-profit organization dedicated to relieving and preventing starvation and malnutrition throughout the world. Meals for Millions supplies MPF for 3 cents a meal to famine areas.

Open the faucets on frozen pipes. Wrap the hot towels or rags around the pipes, beginning at the faucet end and working back toward the water source. You can pour more hot water on the rags as they cool if the pipes haven't thawed. Never attempt to thaw a frozen pipe in the middle. Dammed by ice at both ends, the expanding melting water may burst the pipe. This is especially dangerous in the case of using a blow torch to thaw pipes. The steam exploding from the bursting pipe may scald you. Reverse the procedure in melting frozen sewer pipes, beginning at the sewer end and working toward the fixture. Pour boiling water into frozen drains.

**FOR CUTS AND BRUISES**

Puffball (*Lycoperdon giganteum* or *Calvatia gigantea*). Also called devil's-snuffbox and bullfist, this giant puffball, a species of mushroom, is easy to identify on account of its large size, the size of a human head, as it grows almost stemless in pastures, etc. When fully ripe it evaporates in brown smoke when stepped on. It is this brown powder that was dusted on wounds for its styptic quality. Our Indians even stored the "snuff" for time of need and the British were said to have used some of their puffballs as anesthetic in place of chloroform by burning mature ones and using the fumes.

**How to Live on Nothing**

Joan Ranson Shortney  
1961; 336 pp.

**\$.75** postpaid

from:  
Pocket Books  
A Division of  
Simon & Schuster, Inc.  
630 Fifth Avenue  
New York, N. Y. 10020  
or WHOLE  
EARTH  
CATALOG

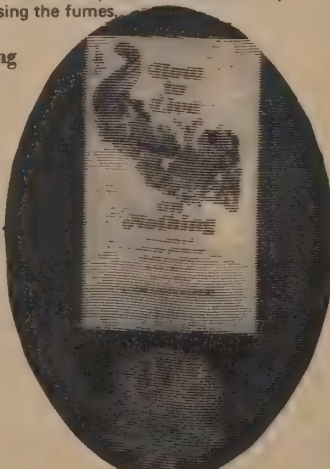

**\* Gestalt Therapy Verbatim**

Fritz Perls makes a career of being usefully insufferable. This book is unvarnished transcript of his groups at Esalen Institute being whipped into shape. How to be a pain in the ass and loved. Kesey likes him a lot. Barry Stevens picks out these Fritz pearls from the beginning of the book:

I have often been called the founder of Gestalt therapy. That's crap. If you call me the finder or re-finder of Gestalt therapy, okeh. Gestalt is as ancient and old as the world itself.

Gestalt philosophy tries to be in harmony with what is.

Take responsibility for every emotion, every movement you make, every thought you have—and shed responsibility for anybody else.

Wanting to be helpful is doomed from the beginning.

Each time you ask the question *Why?* you diminish in stature. You bother yourself with false, unnecessary information. You only feed the computer, the intellect. And the intellect is the whore of intelligence. It's a drag on your life.

Anxiety is the gap between the now and the later.

The organism does not make decisions. Decision is a man-made institution. The organism works always on the basis of preference.

If you feel comfortable in yourself, you don't love yourself and you don't hate yourself, you just live.

The simplicity of the Gestalt approach is that we pay attention to the obvious, to the utmost surface. We don't delve into a region which we don't know anything about, into the so-called unconscious.

Very many people have no center, and without a center you wobble in life.

Any deliberate change is doomed to failure. Change has to come by itself through organismic self-regulation.

We apply enough skillful frustration so that the patient is forced to find his own way, discover his own potential, and discover that what he expects from the therapist, he can do just as well himself.

My whole definition of learning is that learning is discovering that something is possible.

**Gestalt Therapy Verbatim**  
Frederick S. Perls, M. D., Ph. D.  
1969; 279 pp.

**\$3.50** postpaid

from:

Real People Press  
939 Carol Lane  
Lafayette, CA 94549

or WHOLE EARTH CATALOG

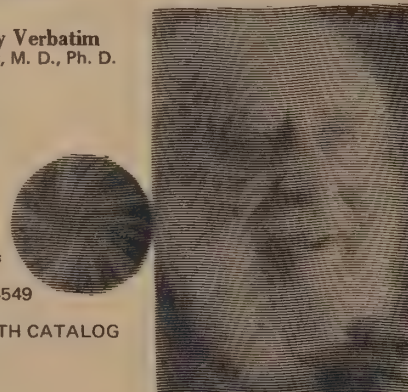

I do my thing, and you do your thing.  
I am not in this world to live up to your expectations  
And you are not in this world to live up to mine.  
You are you and I am I,  
And if by chance we find each other, it's beautiful.  
If not, it can't be helped.

**\* Earth House Hold**

In a clear voice Gary Snyder promotes ecology, communes, and travel. A lot of people are responding in particular to this much-suggested book.

Don't be a mountaineer, be a mountain.  
And shrug off a few with avalanches.

Key to evolution adaptability: the organism alters itself rather than continue fruitless competition.  
... logging camp morning, high clouds moving east, birds, morning light on the pine and sugi;

Comes a time when the poet must choose: either to step deep in the stream of his people, history, tradition, folding and folding himself in wealth of persons and pasts; philosophy, humanity, to become richly foundationed and great and sane and ordered. Or, to step beyond the bound onto the way out, into horrors and angels, possible madness or silly Faustian doom, possible utter transcendence, possible enlightened return, possible ignominious wormish perishing.

The super hunting-bands of mercenaries like Rand or CIA may in some ways belong to the future, if they can be transformed by the ecological conscience, or acid, to which they are very vulnerable.

**Earth House Hold**  
Gary Snyder  
1966; 143 pp.

**\$1.95** postpaid

from:  
New Directions  
Publishing Corporation  
333 Sixth Avenue  
New York, N. Y. 10014

or WHOLE EARTH CATALOG



There is a great truth in the relationship established by hunting: like in love or art, you must become one with the other. (Which is why paleolithic hunting magic is so important historically: the necessities of identity, intuition, stillness, that go with hunting make it seem as though shamanism and yoga and meditation may have their roots in the requirements of the hunter—where a man learns to be motionless for a day, putting his mind in an open state so that his consciousness won't spook creatures that he knows will soon be approaching.)

After breakfast every morning there would be a quiet, natural discussion of the day's work; people would volunteer for various tasks—never any pressuring—somebody might say, "Let's be sure and put the tools back where we got them, I couldn't find the file yesterday" or something—but without acrimony; Westerners have much to learn from this easy cooperativeness and sense of getting the work done without fuss. The Banyan people had less ego-friction (none!) and difficulty over chores than any group I've ever seen.

(Beware of anything that promises freedom or enlightenment—traps for eager and clever fools—a dog has a keener nose—every creature in a cave can justify himself. Three-fourths of philosophy and literature is the talk of people trying to convince themselves that they really like the cage they were tricked into entering.)

We use the term Tribe because it suggests the type of new society now emerging within the industrial nations. In America of course the word has associations with the American Indians, which we like. This new subculture is in fact more similar to that ancient and successful tribe, the European Gypsies—a group without nation or territory which maintains its own values, its language and religion, no matter what contry it may be in.

The Tribe proposes a totally different style: based on community houses, villages and ashrams; tribe-run farms or workshops or companies; large open families; pilgrimages and wanderings from center to center. A synthesis of Gandhian "village anarchism" and I. W. W. syndicalism. Interesting visionary pamphlets along these lines were written several years ago by Gandhians Richard Gregg and Appa Patwardhan. The Tribe proposes personal responsibilities rather than abstract centralized government, taxes and advertising-agency-plus-Mafia type international brainwashing corporations.

How do they recognize each other? Not always by beards, long hair, bare feet or beads. The signal is a bright and tender look; calmness and gentleness, freshness and ease of manner. Men, women and children—all of whom together hope to follow the timeless path of love and wisdom, in affectionate company with the sky, winds, clouds, trees, waters, animals and grasses—this is the tribe.

# Previously listed in Community and still beloved:

## Dune

A more recent Hugo Award winner than *Stranger in a Strange Land*, *Dune* is rich re-readable fantasy with clear portrayal of the fierce environment it takes to cohere a community. It's been enjoying currency in Berkeley and saltier communities such as Libre. The metaphor is ecology. The theme revolution.



**Dune**  
Frank Herbert  
1965; 544 pp.

**\$.95** postpaid

from:  
Ace Books, Inc.  
1120 Avenue of the Americas  
New York, N. Y. 10036

or WHOLE EARTH CATALOG

"These things are so ancient within us," Paul said, "that they're ground into each separate cell of our bodies. We're shaped by such forces. You can say to yourself, 'Yes, I see how such a thing may be.' But when you look inward and confront the raw force of your own life unshielded, you see your peril. You see that this could overwhelm you. The greatest peril to the Giver is the force that takes. The greatest peril to the Taker is the force that gives. It's as easy to be overwhelmed by giving as by taking."

"And you, my son," Jessica asked, "are you one who gives or one who takes?"

"I'm at the fulcrum," he said. "I cannot give without taking and I cannot take without..." He broke off.

## The Politics of the Barrios of Venezuela

Unlike the typical slum quarters of industrialized cities in northern countries, in which old buildings with once-satisfactory facilities have deteriorated over the years, the conditions in most barrios improve with age. In the first stage of development, a barrio consists only of shacks; there are no roads and no water. As time passes, however, such facilities are installed, and houses, instead of degenerating further assume a more stable appearance as their owners invest in improvements. Each new effort adds something that was lacking before. Understanding this feature is essential for understanding barrio culture and for appreciating the difference between living in shantytowns and in traditional slums, where people typically dwell in rented tenements and conditions deteriorate, rather than improve, with time.



**The Politics of the Barrios of Venezuela**

Talton F. Ray  
1969; 211 pp.

**\$7.00** postpaid

from:  
University of California Press  
2223 Fulton Street  
Berkeley, CA 94720  
or  
Room 701  
25 West 45th Street  
New York, N. Y. 10036

or WHOLE EARTH CATALOG

## Synectics

An outline of a method for training creative groups and maintaining their creativity in the business environment. This book provides both the theoretical and experimental background and the practical details of how to put the method to work. Although written for use by business executives, the applications to other situations are obvious and important. Anyone attempting to create a commune or other group of people who will work together creatively will find many useful ideas here. The problem of interface between the creative group and the workaday world is also treated in some detail. Extensive examples of the method in operation, and a lengthy bibliography on creativity.

[Reviewed by Larry McCombs.  
Suggested by Jane Burton.]

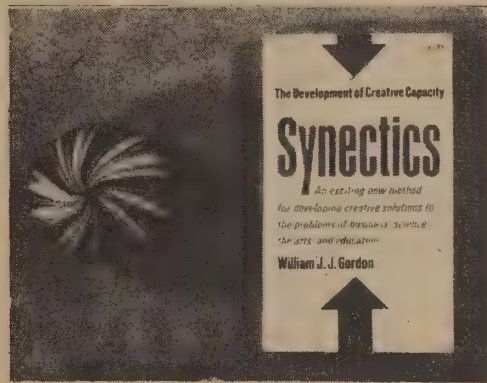

**Synectics**  
William J. J. Gordon  
1961; 180 pp.

**\$1.25** postpaid

from:  
Collier Books  
866 Third Avenue  
New York, N. Y. 10022

or WHOLE EARTH CATALOG

## Person to Person

Barry Stevens is a lady with one of the best popularization formats going. She's taken significant papers of current action in humanistic psychology, and embedded them in a rich collection of her own non-professional living and applying. The papers are by Carl Rogers, Eugene Gendlin, John Shlien, and Wilson Van Dusen.

[Suggested by Barry Stevens]



I saw the Hopi look at Cab so equally that he drew Cab down to his own level—precisely, and not one bit lower—so that they seemed to be two people eye-to-eye. I was so impressed by this that I looked up to the Hopi as though he were some sort of god. The Hopi turned to me with that same strong equalness in his gaze, and I felt myself being drawn up until we were on the same plane.

Abstract talk seems to me not only "in front of the face" but not even in this room or this world. It is like rumors about something real.

**Person to Person**  
Carl Rogers & Barry Stevens  
1967; 276 pp.

**\$3.00** postpaid

from:  
Real People Press  
939 Carol Lane  
Lafayette, CA 94549

or WHOLE EARTH CATALOG

## Tools for Progress

Great Britain does it again (I'm beginning to feel like a Loyalist) way ahead of the let-General-Motors-do-it U. S. Here in one tasty catalog are all the "equipment and materials for small-scale development available in The United Kingdom." Pictures, descriptions, prices, and detailed access information on all manner of do-it-ourself tools, from hand ploughs to air houses. There may be some outrageous bargaining here, or not, I don't know—find out for yourself; a pound equals \$2.40 these days.



### The Emcot

Many thousands of these oxen draught ridging ploughs are being used in developing countries where crops are grown on the ridge to combat soil erosion.

The Emcot ridging plough is used for crops such as groundnuts, cotton, tobacco as well as for cattle feed and vegetables.

The Emcot has replaceable earth wearing parts and is of solid construction for long life.

### Tools for Progress

1968; 192 pp.

**\$2.64** surface postpaid to U. S.

**\$5.00** air postpaid to U. S.

**\$2.10** in London.

from:  
The Intermediate Technology  
Development Group Ltd.  
9 King Street  
Covent Garden  
London, W. C. 2  
ENGLAND

## The Natural Foods Cookbook

Since one of the prime problems of the switch-over from supermarket foods to real foods is where to find them—this book beings appropriately with a check list of basic natural foods followed by a list of supply sources. From there on it's one fine and healthful recipe after another: basics (how to make yoghurt & cheeses, yeast, sprouts, whole grains) to Delights (herbed mushroom casserole, lemon-honey jelly with a few geranium leaves.) Concludes with a list of suppliers of appliances (grinding mills, vegetable steamers, yoghurt incubators). Some of the recipes are clinkers.



### The Natural Foods Cookbook

Beatrice Trum Hunter  
1961; 368 pp.

**\$.95** postpaid

from:  
Pyramid Publications, Inc.  
444 Madison Avenue  
New York, N. Y. 10022

or WHOLE EARTH CATALOG

# Nomadics

## The Complete Walker

Some of them old boys are into making houses out of chicken wire and condoms. Some of them can gather you a salad right off the forest floor. Some can make you a computer out of old Stromberg-Carlson radio parts and have enough wire and tubes left over for two laser death rays and a UFO. But Colin is into walking. His two previous books are mainly about walks: In *THE THOUSAND MILE SUMMER* he tells about one he took up the entire Sierra range, and in *THE MAN WHO WALKED THRU TIME*, he walks the whole Grand Canyon. This one is about walking, not walks. It's not full of lore and woodiness. It doesn't tell you how to get back to nature, or cast civilization from your back and wander out with a bowie knife and a jock-strap. It gives a little walk philosophy, and then proceeds to discuss, in just the right detail, how to put a nice little well-equipped house and its fittings on your back, how to be able to go out and walk for a long time without having to come back for more stuff.

Besides just the stuff, what to take and what to leave behind, it also takes you on a trip through Colin Fletcher, which is quite an outing all by itself. It's hard to imagine a book on backpacking technique that will make you laugh out loud all the way through, but he does it. He really loves poking fun at himself. He gets completely hung up describing some gadget or technique which he then admits he's never tried. He'll spend a whole page defending what seemed at first an impossibly fussy personal idiosyncrasy, and at the end you'll be dying to go out and try it for yourself. He actually has a sizable section on how to urinate and defecate in the outdoors, and it's a fine description. He includes a very complete appendix on suppliers, a list of walking organizations, and even a series of inspiring quotations to read while walking or thinking about walking.

Most important, though, it's the only backpacking book I've ever seen which, if read carefully, will actually tell you how to do it in great enough detail to enable you to just go out and do it. It's also the only one that will really make you want to go out and walk for absolutely no ulterior motive.

Be sure to dig pages 45-52, 123-132, 182-186, 213-218, the whole Furniture and Appliances section, and all the illustrations.

The only adverse comment I would make is that his food preferences seem pretty sanpaku. But he also quotes the old proverb about hell being a place where the politicians are French, the police German, and the cooks English.

[Reviewed by Roland Jacopetti]

First remove any obvious and rectifiable local irritant, such as a fragment of stone or a rucked sock. Then cover the tender place. Cover it even if you can see nothing more than a faint redness. Cover it, in fact, if you can see nothing at all. Being a 'hero' is being a bloody fool. The covering may only be needed for a few hours; if you take it off at night and let the air get at the skin you may not even need to replace it next morning. But if you do nothing at the first warning you may find yourself inside the hour with a blister that will last a week.

## Camping and Woodcraft

How could anything written in 1916 still be so useful? One, it is a masterwork. Two, in Kephart's day when you went camping you really disappeared, so there's a valid nostalgia factor. But the main thing is, the book survives on its wealth of specific practical lore. Game: find the information that is outdated, sort it from the information that is correct and available nowhere else



Camping and Woodcraft \$6.95 postpaid  
Horace Kephart  
1917, 1921, 1967; 479 pp.

from:  
The Macmillan Company  
Front and Brown Streets  
Riverside, Burlington County  
New Jersey, 08075  
or WHOLE EARTH CATALOG

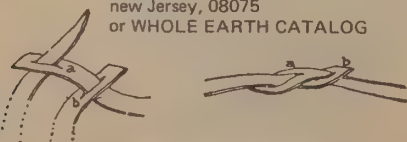
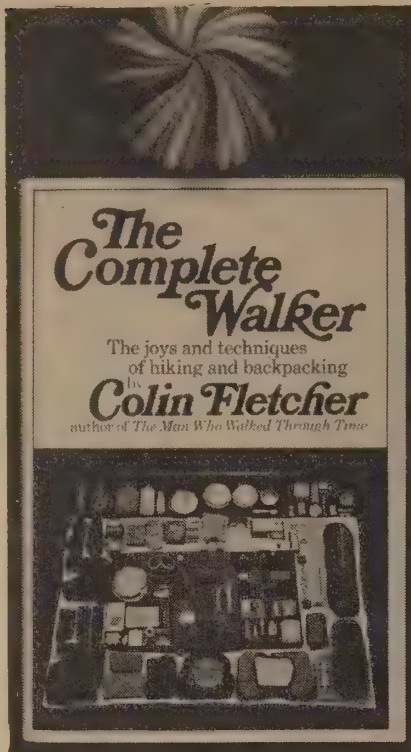

Fig. 185.—Splicing thongs

One of the surest ways to tell an experienced walker from a beginner is the speed at which he starts walking. The beginner tends to tear away in the morning as if he meant to break every record in sight. By contrast, your experienced man seems to amble. But before long, and certainly by evening, their positions have reversed. The beginner is dragging. The expert, still swinging along at the same easy pace, is now the one who looks as though he has records in mind. One friend of mine, a real expert, says, 'If you can't carry on a conversation, you're going too fast.'



The Complete Walker  
Colin Fletcher  
1969; 353 pp.

\$6.95 postpaid from:  
Alfred A. Knopf, Inc.  
33 West 60th St.  
New York, N.Y. 10023

or WHOLE EARTH CATALOG

There is a cardinal rule of travel, all too often overlooked, that I call the Law of Inverse Appreciation.

It states: 'The less there is between you and the environment, the more you appreciate that environment.'

Men working hard in the open, and exposed to the vicissitudes of wilderness life, need a diet rich in protein, fats (especially in cold weather), and sweets. This may not agree with theories of dieticians, but it is the experience of millions of campaigners who know what their work demands. A low-protein diet may be good for men leading soft lives, and for an occasional freak outdoorsman, but try it on an army in the field, or on a crew of lumberjacks, and you will face stark mutiny.

Rabbits are unfit to eat in late summer, as their backs are then infested with warbles, which are the larvae of the rabbit bot-fly.

Green Corn.—If you happen to camp near a farm in the "Roasting-ear" season, you are in great luck. The quickest way to roast an ear of corn is to cut off the butt of the ear closely, so that the pith of the cob is exposed, ream it out a little, impale the cob lengthwise on the end of a long hardwood stick, and turn over the coals.

Skilligalee.—The best thing in a fixed camp is the stock-pot. A large covered pot or enameled pail is reserved for this and nothing else. Into it go all the fag-ends of game—heads, tails, wings, feet, giblets, large bones—also the left-overs of fish, flesh and fowl, of any and all sorts of vegetables, rice, or other cereals, macaroni, stale bread, everything edible except fat. This pot is always kept hot. Its flavors are forever changing, but ever welcome. It is always ready, day or night, for the hungry varlet who missed connections or who wants a bite between meals. No cook who values his peace of mind will fail to have a skilly simmering at all hours.

A woodsman, on the contrary, walks with a rolling motion, his hips swaying an inch or more to the stepping side, and his pace is correspondingly long. This hip action may be noticed to an exaggerated degree in the stride of a professional pedestrian; but the latter walks with a heel-and-toe step, whereas an Indian's or sailor's step is more nearly flat-footed. In the latter case the center of gravity is covered by the whole foot. The poise is as secure as that of a rope-walker.

It is not nearly so much the "make" of rifle as the load it takes that determines the gun's shooting qualities. So, choose first a cartridge, then a gun to handle it.

BENDING WOOD.—Small pieces of green wood can be bent to a required form by merely soaking the



Fig. 54.—Spanish Windlass (for bending wood)

pieces for two or three days in water, but if it is desired that they should retain their new shape, they should be steamed.

When crowds assemble in Trafalgar Square to cheer to the echo the announcement that the government has decided to have them killed, they would not do so if they had all walked 25 miles that day.

Bertrand Russell  
Nobel Prize Acceptance Speech

And the Lord said unto Satan, Whence comest thou? Then Satan answered the Lord, and said, From going to and fro in the earth, and from walking up and down in it.

JOB 1, 7

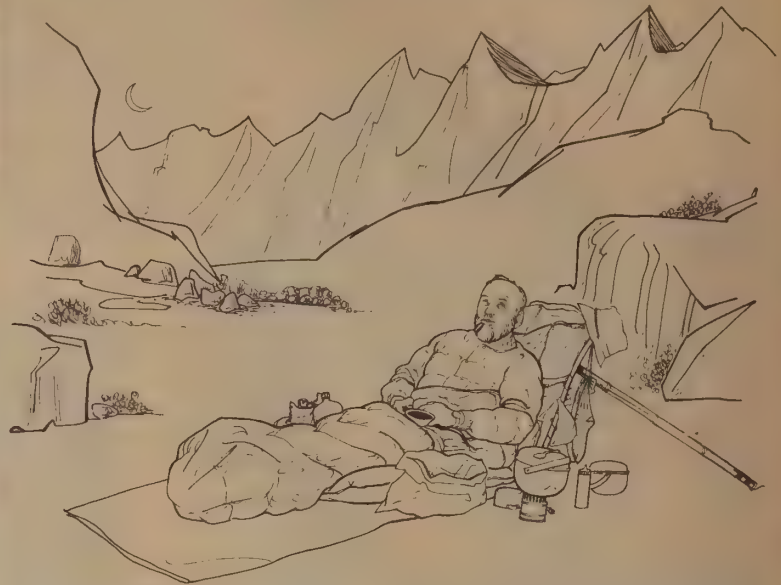

At this point, steam issues from the stew pot. You reduce the heat to dead-low or thereabouts (taking care not to turn the stove off in the process), stir the compound a couple of times, inhale appreciatively and replace the cover. While dinner simmers toward fruition you empty two ounces of dehydrated peaches and a little water into the small cooking pot and put it ready for breakfast, up alongside the pack. Then you jot down a few thoughts in your notebook, stir the stew and sample it, find the beans are not quite soft yet. So you study the map and worry a bit about the morning's route, put map and pen and pencil and eyeglasses and thermometer into the bedside boots, take off your shorts and slide halfway down into the mummy bag out of the wind, and stir the stew again and find all ready. You pour-and-spoon out a cupful, leaving the balance on the stove because the wind is blowing distinctly cool now. And then, leaning comfortably back against the pack and watching the sky and the black peaks meld, you eat, cupful by cupful, your dinner. You finish it—just. Then you spoon-scrape out every last possible fragment and polish-clean the pot and cup and spoon with a piece of toilet paper. You put the paper under the stove so that you can burn it in the morning. Then you put cup and spoon into the breakfast-readied small pot, pour the morning tea water into the big pot, set the big pot alongside the small one and the sugar and milk containers alongside them both, put the current day's ration bag into the pack (where it is moderately safe from mice and their night allies) and...

### Office-on-the-yoke

Because I so often walk without a shirt and therefore without a front pocket, I have had a five-by-six-inch pocket sewn onto the front of my yoke strap, roughly where the shirt pocket comes. Into it go notebook and map, and sunglasses when not in use. Pen, pencil, camel-hair lens brush (page 233), and metal-cased thermometer (page 259) clip onto the front of it. I cannot imagine how I ever got along without such a pocket. Mine is made of ordinary blue-jean material, but anything stout will do.

For which side to put your office, see page 64.

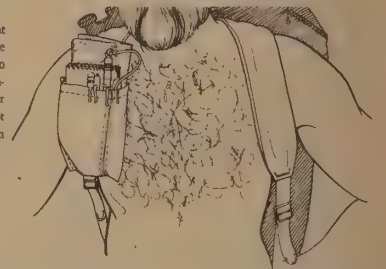

In Alaska, all animals leave for the snow-line as soon as the mosquito pest appears, but the enemy follows them even to the mountain tops above timber-line. Deer and Moose are killed by mosquitoes, which settle upon them in such amazing swarms that the unfortunate beasts succumb from literally having the blood sucked out of their bodies. Bears are driven frantic, are totally blinded, mire in the mud, and starve to death. Animals that survive have their flesh discolored all through, and even their marrow is reduced to the consistency of blood and water. The men who penetrate such regions are not the kind that would allow toil or privation to break their spirit, but they become so unstrung from days and nights of continuous torment inflicted by enemies insignificant in size but infinite in number, that they become savage, desperate, and sometimes even weep in sheer helpless anger.



Fig. 68.—A Masked Camp

Trees and Lightning.—I have never seen, nor heard of, a beech tree that had been struck by lightning, although beeches are plentiful on many battle-scarred mountains where stricken trees of other species can be noted by the score.

One glance at a camper's fire tells what kind of a woodsman he is. It is quite impossible to prepare a good meal over a heap of smoking chunks, a fierce blaze, or a great bed of coals that will warp iron and melt everything else.

## Notes on Nomad Equipment

It is important to have gear that is well made and really does the job. But often the more expensive stuff is more specialized than what is needed—and sometimes actually becomes a liability.

- 1) Sleeping bags—If you're not sleeping where it gets below freezing—and weight and storage bulk is no big problem, then a good dacron filled bag (\$25) may be superior to a down bag (\$75-100). Dacron doesn't mat down very much so there is no necessity for a foam pad or air mattress (needed for insulation and comfort with down bags). Also, dacron is easier to maintain. Rectangular bags are more comfortable but not as warm as mummies.
- 2) Boots—Guys often buy boots much heavier, bulkier, and stiffer than they need. Boots that weigh 3 pounds (like the Voyager "Hiker") are much more comfortable than those in the 5-6 pound range—which are more expensive and only necessary in severe cold or extremely rugged conditions.
- 3) Water-proofing—This is a real problem. Garments that are really water-proof will get you soaking wet from interior condensation caused by your own body heat. The only way to stay dry (out doors) in a good down pour is to wear a parka that "breathes"—passes both air and moisture—underneath a loose fitting poncho. Fabrics that "breathe but are water-proof" are introduced each year. They never seem to work. Tightly woven or knitted wool takes a long time to soak through and still retains insulative quality. Nylon shell down filled stuff is practically useless once it gets wet.
- 4) Four Wheel Drive—Almost everyone wants it but hardly anyone ever needs it. They get low gas mileage and have low high-way speeds. Besides, in most places and cases they shouldn't even be there—cutting up the land, making noise and smog, and being ugly. Snow and mud tires on a truck or microbus are more versatile for general use (and cheaper to buy, run and maintain).
- 5) Sponges—use one to dry off before coming inside. Also to dry tent floors.
- 6) Velcro—that's the stuff where you press a fuzzy tape of hooks onto another tape of loops. A good fastener for homemade clothing and things like attaching curtains to campers. Just sew on or glue.

Drew Langsner  
San Francisco, CA

## ★ Chouinard Equipment for Alpinists

Almost everyone who goes into the mountains eventually develops an urge to try rock scrambling or climbing of some kind. It is therefore important to be aware of the best safety procedures and climbing aids available.

Alpinists Yvon Chouinard and Tom Frost design and fabricate a high quality selection of modern climbing equipment. Along with descriptions and illustrations of gear, their definitive catalog includes sections on history, use, care and precautions. There is even a beautifully illustrated article on ice climbing.

[Suggested and reviewed by  
Drew Langsner]

Catalog  
free

from:  
Chouinard  
Box 150  
Ventura, CA 93001



## BONG BONGS

Bongs were originally used only on the El Capitan walls but have since become a necessity even on some practice climbs. When properly placed they have the greatest holding power of any piton. They are blanked and formed from high strength aluminum alloy, plated for corrosion resistance and have a riveted head to prevent over-expansion while driving. All four sizes have lightening holes which not only save weight but also provide eyes for carabiners or tie-off loops. The 2" Bong is made in alloy steel as well as aluminum.



Many deaths in the outdoors, not only in the mountains, but in hunting, boating, hiking and many other outdoor activities, have always been attributed by the news media to "exposure," a vague and rather misleading non-medical term. It has become increasingly apparent that many, if not most of these deaths are actually due to accidental hypothermia. Even recognition by physicians has not been general, partly because the usual medical thermometer does not read below 94° F., and is even difficult to shake down that low, but mostly to the fact that the clinical manifestations can stimulate traumatic shock, many diseases, or the effects of alcohol or drugs.

## ★ Mountaineering: The Freedom of the Hills

By far the most complete and sensitive treatment of mountaineering available. Oriented around Pacific Northwest mountaineering, where trails often end miles before the peaks begin, it is particularly relevant to wilderness camping and travel. It is much more than a book on how to climb. Reflects several generations of respectful relationship with mountains. If you move (or sit) where there are trees, rocks, snow, and brush, it speaks to your terrain. One limitation: little about dry, arid areas—glaciers are the local functional equivalent of deserts.

[Reviewed by Michael Templeton.  
Suggested by everybody.]

In recent years many a mountaineer has developed the habit or hobby of not only making his own passage invisible but of spending extra effort to obliterate evidence of his predecessors—most of whom were just ignorant and thoughtless.

To the crafts of rock climbing, rock mountaineering adds routefinding—the most difficult and the most rewarding of alpine arts. The art is not mastered quickly. Many a person becomes highly skilled in climbing rock while still utterly ignorant about choosing the best rock to climb.

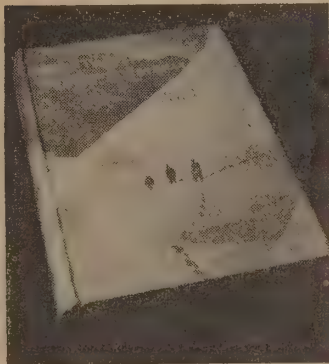

Mountaineering:  
The Freedom of the Hills  
ed. Harvey Manning  
1960, 1967; 485 pp.

\$7.50 postpaid  
from:  
The Mountaineers  
P. O. Box 122  
Seattle, Wash. 98111

or WHOLE EARTH  
CATALOG

Belay (when ready with belay): "Belay on."  
Climber: "Climbing."  
Climber (when rope is too loose): "Up rope."  
(when more rope is needed): "Stack."  
(for a taut rope to hold his weight): "Tension."  
Climber (when safe): "Off belay."  
Belay (responding): "Belay off."  
Both (when needed): "ROCK!"  
Climber (if it happens): "FALLING!"

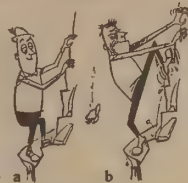

Fig. 22. Footholds.  
a. Correct—close together.  
b. Incorrect—too far apart.

If a skirmish with brush must be accepted there is no technique at all. Brushfighting is not a diversion for civilized, gentle folk. One cannot afford charity toward slide alder or devil's club; one must hate and punish and kill when possible.

## ★ Summit

The only monthly magazine published in the U. S. devoted to mountaineering fortunately covers all phases. Articles range from accounts of "treks" in Nepal and even more remote areas to logs and descriptions of spectacular climbing achievements. Of special interest has been their publication of good medical articles pertinent to conditions such as altitude, cold, and fatigue.

[Suggested and reviewed by  
Drew Langsner]

Summit  
\$6.00 a year (10 issues)

from:  
Summit  
Big Bear Lake  
California 92315

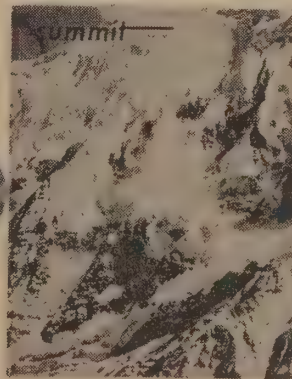
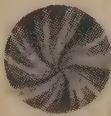

The deadly effects of hypothermia are primarily circulatory and cardiac, with rather characteristic electro-cardiographic changes, and the secondary pulmonary vascular congestion and pulmonary edema tends to simulate the entity of high altitude pulmonary edema, with foaming at the mouth. Hypothermia is generally considered to exist when the body temperature, rectally, falls below 95° F., with degrees between 90-95° F. requiring only vigorous supportive care, while temperatures below 90° F. require immediate and sometimes heroic medical treatment. In the infamous Dachau experiments on seven unanesthetized healthy human subjects intentionally chilled in ice water, death occurred between 75.2-84.2° F. with an average value of 80.6° F.



The quest of the mountaineer, in simplest terms, is for the freedom of the hills, to be fully at home in the high wilderness with no barriers he cannot pass, no dangers he cannot avoid.

The leader must be inspiring, as inspiring as the occasion demands. If the rising hour is 2 a.m., the leader rises then; he may not want to, but he does. If the summit is near and the time is short, he does not merely decide to continue or retreat; he gets everyone to decide the same way. In crisis he is firm; in ordeal he is the example of fortitude; in disaster he controls himself, and leads his companions to control of the situation. He must combat lassitude and despondency; he must curb greed and anger; he must avoid panic and despair. He may be the strong, silent type or the "talk it up, gang!" type; whoever he is, he must inspire and control himself before he can inspire and control others.

## COOKING AND EATING UTENSILS

The least-expensive cooking utensils are tin cans in various sizes, junked (at home, not in the mountains) when rusty. Aluminum utensils cost a little more but are more durable. Bails are desirable for suspending pots over the fire, and lids to keep ashes out and steam in. Aluminum foil is versatile beyond description, under adept manipulation becoming a frying pan, oven for baking foods in a bed of coals, reflector oven for biscuits, and if need be even a cup or a pot.

With a poly bottle, or a canteen of anodized aluminum, a climber can enjoy fruit juices untainted by the toxic metal salts generated in containers of steel or untreated aluminum.

## BREAKFAST

If the climb begins in the middle of the night, breakfast is merely the first installment of lunch. A tiny can of fruit cocktail, or a doughnut and a swallow of milk, are typical menus. Some climbers are convinced their legs won't work without hot food; their neurosis can be quickly pampered with instant cereal or cocoa cooked by chemical fire.

## LUNCH

As soon as breakfast is completed the climber commences lunch, which he continues to eat as long as he is awake, stopping briefly for supper. He has food in his rucksack and knick-knacks in his pockets, main courses for the summit lunch, nibbles for rest-stops, and sweets to suck while walking.

For special purposes a hunting knife is superior, as are double bitted axes, cavalry sabers, Getling guns, and dynamite, but the modest mountaineer contents himself with a modest blade.

## ★ Mountaineering Medicine

It is small enough to carry any time you go into an isolated or hazardous area; well organized, and fairly up-to-date. There are sections on various injuries, snow blindness, bites and stings, sunburn, water purification, etc.. The booklet concludes with a section on making and using a first aid kit. (You'll need a physician to write scrips for certain drugs listed.)

[Suggested and reviewed by  
Drew Langsner]



Mountaineering  
Medicine  
Fred Darvill, Jr., M. D.  
1966, 1968; 35 pp.

\$1.00 postpaid from:  
Skagit Mountain Rescue Unit  
P. O. Box 2  
Mt. Vernon, Wash. 98273

## IMPORTANT!

Some of the information contained herein is a part of the practice of medicine rather than first aid (i.e. reducing a dislocated shoulder, use of morphine and antibiotics, etc.). Use of this data as recommended is more likely to benefit than to harm when INJURY OR ILLNESS OCCUR IN THE WILDERNESS far from a physician or hospital; however, these techniques should not be used by relatively untrained persons if professional assistance is close at hand.

Always carry these essentials for climbing and wilderness travel:

1. Map of area
2. Compass
3. Flashlight
4. Matches & candle
5. Sun glasses & sun cream (Solex or Uval)
6. Knife
7. Extra food
8. Extra clothing
9. First aid kit (see page 31)

**Light Weight Camping Equipment and How to Make It**

*It's all here: design, patterns, assembly techniques, light weight materials, and sources of the materials. Because of good information on what's needed for various environments, it's a useful book even if you aren't making your own stuff. An indispensable book if you are.*

[Suggested by Roland Jacopetti]

**Light Weight Camping Equipment**  
Gerry Cunningham, Margaret Hansson  
1959; 130pp.

**\$2.00** postpaid

from:  
Gerry  
P. O. Box 5544  
Denver, Colorado 80217

or **WHOLE EARTH CATALOG**



**Parka**



**\* Frostline Outdoor Equipment**

Frostline Outdoor Equipment is the manufacturer of do-it-yourself kits of lightweight camping equipment: tents, down sleeping bags and clothing. They also sell the raw materials for making such equipment (pre-packaged down; zippers; nylon fabrics; velcro self-sticking nylon tape fastener; Dacron thread; etc. The company's service by mail has proven prompt and dependable, all of this reviewer's orders having been filled correctly.

This reviewer has made Frostline's "Big Horn" ("Winter") sleeping bag (2 1/2 lb. down filled overlapping tube design with no stitched through seams), stuff sack and poncho. She found each kit to be all that the manufacturer had claimed, the catalog description scrupulously accurate.

Frostline kits are complete, all they require is assembly with a sewing machine. This reviewer used a Singer Featherweight for the purpose.

Before deciding on the Frostline kits this reviewer compared Frostline prices and specifications with those of other companies. (The Ski Hut, Recreational Equipment Inc., Thomas Black and Sons Inc., etc.) She concluded that the Frostline kits were the most economical product without any compromise in quality.

[Reviewed by Roberta Becker Marshall. Suggested by many.]

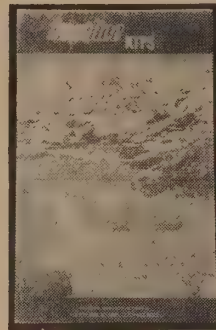

**Catalog free**

from:  
Frostline Outdoor Equipment  
P. O. Box 1378  
Boulder, Colorado 80302

Sample prices:

- 2-man Rain Tent: \$37.95
- "Chamois" down sleeping bag: \$45.95
- "Tundra" down jacket: \$23.50
- Poncho: \$7.95
- Velcro: 30¢ per foot

**L. L. Bean**

The Bean catalog is the model for the **WHOLE EARTH CATALOG**. Mr. Bean had a directness and integrity that shows through his catalog, his products, his service. The catalog has excellent items, especially outdoor clothing. An uncommonly pleasant company to do business with.

**Heavy Duty Grid**

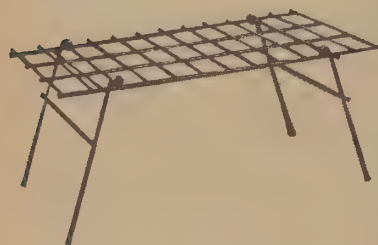

Made to hold cooking utensils over open fires. Has large cooking surface of heavy welded bars. Legs slope outward to stand rigidly on any flat surface and fold against grid for easy carrying. Will hold 250 lbs. Size 12" x 24" x 10 1/4" high. Weight 6 1/2 lbs. Price, \$5.60, postpaid.



**Wallabees®**  
(For Men and Women)

A new design by Clarks of England for complete walking comfort. Fit perfectly on the first wearing. Special "Nature Form" lasts fit the natural contours of the feet. Do not restrict them in any way yet provide firm support. Glove leather uppers of full grained European calfskin suede. Extra thick, soft and supple. Wedge type soles of Plantation crepe rubber have a resilience not found in synthetic crepes.

Moccasin construction with hand sewed toe piece. Molded, orthopedic-type arch support enclosed in sponge rubber and vented leather insole. Firm heel counters, bellows tongue and elasticized laces for snug, non-binding fit. Color, Sand Suede.

**Men's Ankle Height (above):**  
Sizes 7 to 13. Whole and half sizes. (No size 12 1/2.)  
Medium width.  
Price, Men's Ankle Height Wallabees, \$23.95 a pair postpaid.

**Ladies' Low Cut (at right):**  
Sizes 5 to 10. Whole and half sizes.  
Medium width.  
Price, Ladies' Low Cut Wallabees, \$21.95 a pair postpaid.



**Bean's Maine Hunting Shoe**

Mr. Bean first developed this boot in 1912. He combined the lightweight, snug fit of custom made leather tops with the protective, waterproof features of rubber bottoms. The practical advantages of this design made his Maine Hunting Shoe an immediate success. Continuous improvements in material and construction have been added. But the basic design has yet to be improved for all weather and all purpose outdoors comfort. Uppers are of supple, long wearing full grain cowhide. Dry elk-tanned finish or slightly heavier and water repellent oil grain finish. Bottoms of tough, ozone resistant rubber with cushioned innersole. Outersole of durable crepe is permanently vulcanized to the vamp and features Bean's famous non-slip chain tread.



Sizes 3 to 14 D (Narrow) and EE (Medium.)  
6 to 14FF (Wide.) **Whole sizes only.**  
If you do not know your size, give size and width of dress shoe and/or enclose outline of bare foot.  
**Tops come in three leg sizes, Slim or Medium or Full.** State circumference of bare leg at height of shoe ordered. Heights are measured from the floor.  
**Elk-tanned Cowhide Tops (Tan with Reddish Brown Bottoms)**  
6" \$16.00. 8" \$17.00. 10" \$19.00. 12" \$21.00.  
(Size 9 EE in 10" height weighs 2 lbs. 13 oz.)  
**Oil Grain Cowhide Tops (Brown with Reddish Brown Bottoms)**  
6" \$16.85. 8" \$17.85. 10" \$19.85. 12" \$21.85.  
14" \$23.85. 16" \$26.85.  
(Size 9 EE in 10" height weighs 3 lbs. 2 oz.)  
For lacing hooks add 50c. **All prices postpaid.**



Catalog free  
from:  
L. L. Bean, Inc.  
Freeport,  
Me. 04032

**Ski Hut**

Roland Jacopetti is one of our main sources of information and judgment on outdoor equipment. He works at the Ski Hut, a supplier of outdoor equipment in Berkeley, which puts him in a conflict-of-interest bind around reviewing his employer. We shared the bind until enough evidence came in from elsewhere that Ski Hut is a source indeed competitive with others listed here. Colin Fletcher (Complete Walker) gives it top rating for comprehensiveness.

Ski Hut Catalog from: The Ski Hut 1615 University Avenue Berkeley, CA 94703 free

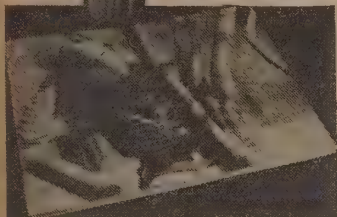

**FOLDING HUNTER—Model 110**  
4" blade pivots on 1/4" bearing and has positive lock in open position. Handle is golden-grain Macassar ebony wood with solid brass bolsters and liner cast in one piece. May be carried in pocket or sheath. An ideal heavy-duty outdoor knife for those preferring a folding blade. Overall length when closed is 5". Weight with sheath, 8 oz.  
J110 ..... \$16.00

**TRAILWISE LOGAN JACKET**  
Designed as an intermediate-weight, all-around down jacket for mountaineering, skiing and camping. We found this jacket to be just as useful at 19,000 feet on Mt. Logan as it is around Yosemite Valley, or on a Sierra ski-tour. The Logan Jacket has the warmth of several sweaters, with less weight—and is easily carried in a corner of your pack until needed. Filled with grey goose down, shell of tough Supernyl, a 3 1/2" high down collar, and elastic knit cuffs. Down insulated pockets and optional down hood. This is the only jacket of its kind that solves the controversial question: Zipper vs. Snaps? The Logan Model has both heavy-duty snaps and a full nylon zipper with a 2" overlap. Colors: Royal blue, chianti, green. Weight: 21 oz. Sizes: small, medium, large. Stuffbag included.  
A111 ..... \$30.00  
A111-H Down hood for Logan Jacket .. \$6.00

**SIERRA CLUB STAINLESS STEEL CUP.** Stainless steel is far superior to other metals because it is less prone to heat up when filled with hot liquids. The open end steel wire handle remains cool and can be hooked easily onto belt. Multi-purpose design for holding stewed fruits, cereals, etc. as well as beverages. 4 1/2" diameter at top, 3 1/8" at base, 1 1/2" deep. Wt. 3 oz. U400 ..... \$ 1.25

**COLLAPSIBLE WATER BAG.** Thick, flexible vinyl container holds 11 quarts. Rolls up to 1" x 1 1/2". Removable spigot at bottom. Handles at both ends. Convenient water supply for an evening's cooking. Wt. 7 oz. U662 ..... \$3.50



**CRUISER CONTOURED ALUMINUM FRAME.** Low cost serviceable model aluminum frame with welded joints. Shoulder straps are 2" wide, padded, and nylon-covered. Back bands are 4 1/2" wide, of heavy cotton duck. This frame is superior in comfort to any other frame in its price range that we know. Two sizes: Large, for people over 5'5"; Medium, for those under 5'5". Weight: 34 oz.  
Large Cruiser Frame: R400/L ..... \$11.75  
Medium Cruiser Frame: R400/R ..... \$11.75



**CRUISER #440 PACKSACK.** Made of durable cotton duck, khaki in color. Two side pockets and one back pocket with tie-down cords. Sack fits on Cruiser frame in seconds. Two sizes fit the equivalent frame size.  
Large #440 Packsack: 14" wide, 22" high, 7" deep. Wt. 20 oz. R401/L ..... \$8.00  
Regular #440 Packsack: 14" wide, 18" high, 6" deep. Wt. 18 oz. R401/R ..... \$8.00



**Sierra Designs**

They are very, very nice people, and I truly believe they make the best available sleeping bags. Design, workmanship, materials, aesthetic beauty, all tops. Prices are high, but not that much higher than everyone else. If you're looking for the best, they've got it.

[Reviewed by Roland Jacopetti. Suggested by Sandra Tcherepnin]

Catalog from: Sierra Designs 4th and Addison Streets Berkeley, CA 94710 free

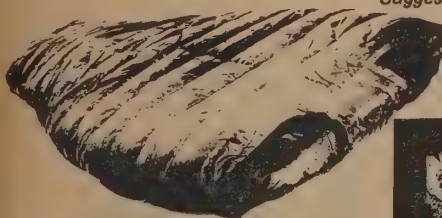

**DOUBLE MUMMY**

Matchless sleeping comfort for two. Double Mummy is lighter, cheaper and more efficient than any combination of zipped-together singles. Its 6 1/2 lbs. is a tolerable pack-weight: packed size of 11"x21" allows the Double to be carried on almost any good pack-frame, and your partner is freed of the largest single part of her pack. Each side of bag has its own 66" nylon zipper, and separate draw closure hoods allow individual ventilation control. Double Mummy comes in a single length—for persons to 6'3". It's not designed for single use, but quite a few heavyweights buy it for that: it provides luxurious space for really hilly people. STUFF SACK INCLUDED

COLORS: Deep Blue or Forest Green. \$126.50  
SPECIFICATIONS:  
Construction: Slant wall, 6" tubular width.  
Weight: 6 1/2 lbs.  
Filling: Prime Silver-Gray goose-down, 3 lbs. 6 oz.  
Stuffed Size: 11"x21"



SIERRA DESIGNS 69/70

**WIND & RAIN**

**60/40 MOUNTAIN RAIN PARKA**

Made of nylon/cotton fabric for maximum wear and excellent comfort due to superior breathing qualities and the pleasant texture of cotton blended with nylon. This parka has stand collar with chinbar and sportswear who will carry a few ounces extra to obtain a lighter garment. A good bit of detail is built into the parka. Cuffs are gusseted and close with Velcro. A wide range of adjustment is possible and ventilation should be considerable at the wrist. Four front pockets are bellows-patch type with Velcro closed flaps. Rear of parka has tapered pocket that allows sweater, etc., to be carried at back. Parka is lined from head to heel. Drawcord at waist, and drawcords for hood with friction sliders of leather. Frost zipper of nylon in #7 industrial size. Upper covered with silicon flap that closes with snaps. Parka cut generously for wear over insulating layer. Sizes: S, SM, M, MD, LG, X-LG. Colors: Navy Orange, Forest Green. Wt.: 34 oz. (Lgt.) \$31.50

Depending on geography and the season there is sometimes a need for a parka of this type. This parka is not recommended for general mountain use because it will not breathe and the wearer is subject to overheating and problems with condensation. To combat this we have designed the parka to have good ventilation control. Cuffs are gusseted and close with Velcro so they can be more loose if desired. A welt is built across the back, it has a screen seam in and covered with a shed. Full nylon zipper front allows ventilation in keeping with conditions. Parka is so constructed as we can make it without using any piece of plastic. Two-ply nylon fabric is treated with an extra thick application of polyurethane and same on the inside. Upper part of parka is lined to protect coating. Two breast pockets provided with zipper closures. Drawcord at waist. Colors: Red or Blue. Sizes: S, SM, M, MD, LG, X-LG. Wt.: 18 oz. \$29.50



**Recreational Equipment, Inc.**

"The Co-op" as it's called, probably offers the widest selection of camping and climbing gear available in the U. S. They carry many outstanding lines of gear; sometimes confusingly too many (their catalog shows 21 different ice axes!) I fully recommend the French Millet rucksacks (especially the ones with tough canvas sacks and leather bottoms) and their own line of Cruiser packs... both good values. Some of their "special imports" (from Japan) are cheap in quality besides price. For instance rubber water-proof coating peeled off scree gaters after 2-3 uses but they took them back for full credit two years later.

Membership is \$1 and you get approximately a 10% dividend each year.

[Reviewed by Drew Langsner. Suggested by Roland Jacopetti.]



Catalog from: Recreational Equipment, Inc. 1525 11th Ave. Seattle, Wash. 98122 free

[F] Millet 370. An expedition sack of blue or grey cotton canvas with a leather bottom that comes 7" up on the sides. All nylon fittings with padded shoulder straps, crampion, ice axe and ski carrying straps and a hauling loop, plus a waist strap. No outside pockets, but with a compartment on top of the head flap and a map pocket inside. Bag size is 7"x17"x24" with long straps on the head flap. The frame is removable for easier packing. 3 3/4 lbs.  
C070A26 ..... 24.95



**CANDLE LANTERNS**

[C] [C] French Candle Lantern. Made of aluminum with a glass chimney, it folds to 2"x4 1/2" long and includes a chain for hanging. Uses the excel candles by cutting about 1/2" off the bottom. Spring mechanism keeps the candle burning at a uniform height. Weight 4 3/4 oz.  
L071C1 ..... 2.85

**BULK PACKED FREEZE-DRIED FOOD**

These larger quantities are suitable for expeditions. They must be re-sealed after only partial use to prevent spoiling.

**3 Quarts in Polybags.** Packed in cardboard cartons.  
Corn, whole kernel, 16 oz. .... K404A13 2.95  
Peas, garden, 16 oz. .... K404A14 3.50  
Strawberries, 8 oz. .... K404A15 5.50  
Peaches, 8 oz. .... K404A16 4.50  
Beef Patties, #10 tin, 1 3/4 lbs. .... K404A33 9.75

**#2 1/2 SEALED TINS**  
Alaska King Crab, net weight 4 3/4 oz. cooked. .... K404A18 4.25

**FENWICK RODS**

[A] Fenwick Rods. Consist of four tubular glass sections which approximate one-piece action when assembled due to the fiber-glass slip joints which eliminate the need for metal ferrule joints. Rods have full cut cork grips, anodized aluminum reel seats, are resin finished and packed in aluminum cases with plastic caps. Fly rod case is 26 1/2" long. Spin-Fly rod case is 23 1/4" long.  
S662B1 7 1/2' Fly Rod, 14 1/2 oz. .... 29.95  
S662B2 7' Spin-Fly Rod, 14 1/4 oz. .... 29.95

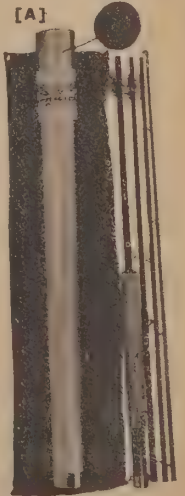
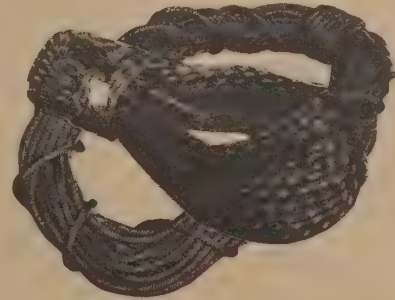

**DYNAMIC ROPE**

In recent years, the Europeans have developed a new climbing rope using a solid core of parallel strands of nylon surrounded by a woven sheath. This has been found to be very strong and easy to handle, having less tendency to kink in use. Called "Dynamic," it has an elasticity of about 80% at rupture, thus giving greater protection to the climber during a fall. The tensile strength is, however, somewhat less. This new rope has been given the stamp of approval by the U.I.A.A. (Union International des Associations d'Alpinisme), who, through their testing, have set standards for maximum safety to climbers. Note: 9mm rope is recommended for double-line use.

[B] Mammut Dynamic Rope. Swiss made, red.  
9mmx120', 5 lbs. .... B218A22 20.95  
9mmx150', 6 lbs. .... B218A21 24.95



**Adjustable Tent Poles.** Lightweight aluminum 2-piece telescoping poles. Folding down to average 4'. Ideal for tarps, tent awnings, etc.  
E459C22 6' length, 18 oz. .... 1.85  
E459C23 7' length, 20 oz. .... 2.10  
E459C24 8' length, 22 oz. .... 2.45

[C] Collapsible P-88 Tent Pole. A four-section pole used with McKinley or Camper tents. Extends to 88" and collapses to 25"x 1 1/4" diameter. Weight 2 3/4 oz.  
E657C4 ..... 4.95

★ **Warmlite Tent**

The Stephenson Warmlite tent is the 2-3 man tent for backpacking and mountaineering. The basic Model 6—Single Wall Tent weighs 36 ounces complete with poles. It has been designed by Jack Stephenson, an aerodynamicist and mechanical engineer, who fabricates them as a part-time operation at home. The tapered hoop shape is very stable and doesn't flap in the wind. It also provides extra interior head room compared to conventional A-frame designs. Interior thermodynamics are designed to provide good ventilation and minimize heat loss. Length is over 10 feet, width of 5 feet. Fits in small size sleeping bag stuff sack. \$94-\$138.

Catalog free [Suggested and reviewed by Drew Langsner]

from: Stephenson's  
23206 Hatteras Street  
Woodland Hills, CA 91364



★ **Eddie Bauer**

Highly-regarded for their down products—parkas, sleeping bags, etc. Very affluent catalog. They developed a flotation wet-suit that I like a lot.

Catalog free

from: Eddie Bauer  
Expedition Outfitter  
1737 Airport Way South  
Seattle, Washington 98134

4-Ply Laminated Tubes



No. 0305 STANDARD. For those under 6-ft. tall. 2½ lbs. 100% New Premium Quality Bauer Goose Down. Bag measures 81" x 30", tapers from 30" at top to 16" at feet. Weighs 3½ lbs. ppd. \$49.50 ©

No. 0306 LONG SIZE. For those over 6-ft. tall. 2½ lbs. 100% New Premium Quality Bauer Goose Down. Bag measures 86" x 30", tapers from 30" at top to 16" at feet. Weighs 3½ lbs. ppd. \$54.50 ©

Men's Long Coverall AMPHIBIOUS† Sports Suits. Colors: Red, Navy, Orange. Sizes: S(34-36), M(38-40), L(42-44), XL(46).

No. 2280 ppd. \$99.50 ©

Women's Long Coverall AMPHIBIOUS† Sports Suits. Colors: Orange, Powder Blue, Red, Pink. Sizes: XS(7-9), S(10-12), M(14-16), L(18-20).

No. 2281 ppd. \$95.00 ©

KELTY PACK PRICES					
PACKFRAME MODEL — All Sizes —	PACKBAG MODEL — All Sizes — Both Colors				
	A2	A4	B2	B4	B85
Mountaineer	45 25	49 50	41 50	45 25	53 50
Backpacker	43 00	47 25	39 25	43 00	51 25

★ **Kelty Packs**

Famous packs.

Catalog free

from: Kelty Pack  
1801 Victory Boulevard  
Glendale, CA 91201

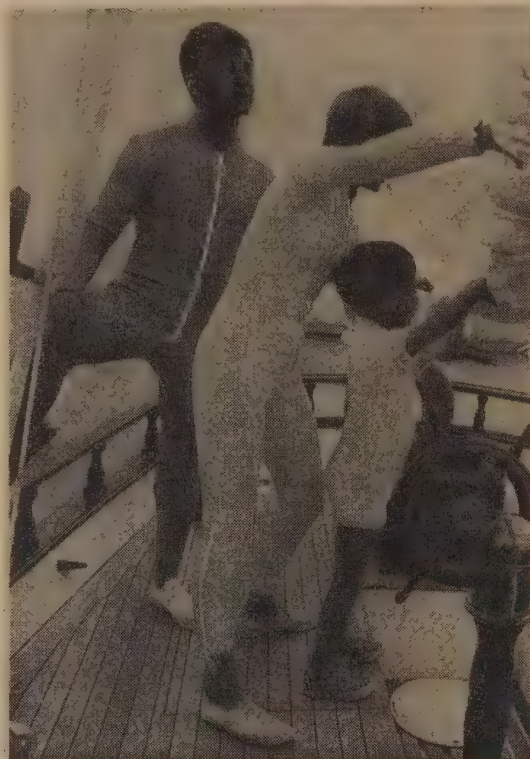

★ **Camp and Trail**

The most beloved of the New York outdoor suppliers.

[Suggested by Annie Helmuth]

Catalog free

from: Camp and Trail Outfitters  
112 Chambers Street  
New York, N. Y. 10007

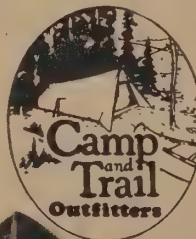

No. 159. LENNAN RUBBER LIGHT.

A 2 cell waterproof, damage proof flashlight. Has a very excellent switch. Wt. empty, 8 ozs. \$2.95



No. 163. MALLORY POCKET FLASHLIGHT.

Complete with two Penlite Alkaline Manganese batteries. 5 Hours continuous light, 8-1/2 hrs. intermittent. Has a 2 yr. shelf life, wt. 4 ozs. 4" long, 1-1/2" thick. \$1.98

Replacement batteries 50¢ each.

★ **Barbour**

Here in California, Barbour all-weather gear looks hopelessly exotic. Appropriate dress for leaning against the straining helm or sneaking into East Germany in November and other romances. Has anyone used their stuff that would tell us if it keeps the rain out comfortably? [Suggested by Jerome Skuba]

L/W Thornproof Racing Oversuit . . . . . \$22.00

Catalog free

from: J. Barbour and Sons, Ltd.  
Simonside, South Shields  
Co. Durham, ENGLAND



★ **Black's**

Said to be the largest camping equipment supplier in England, Black's has an outlet in New York State.

[Suggested by Jerome Skuba]

Catalog free

from: Thomas Black & Sons  
930 Ford Street  
Ogdensburg, N. Y. 13669



**RUSSELL KNIVES**

The original Custom crafted Canadian Design Award Knives for every outdoorsman. Guaranteed quality. Complete with hand moulded oil tanned leather sheaths.

The Belt knife is the original design with unique elliptical blade ideal for game dressing or general purpose. Blade 4 ins. x 1 in. Total length 8½ ins. Weight 5 oz. (68-8101) \$13.95

The Trout and Bird Knife is a smaller version of the Belt knife for smaller game and fish dressing as well as general outdoor needs. Blade 3½ ins. x ½ in. Total 8½ ins. Wt. 4oz. (68-8102) \$11.95

The Boat Knife is a general purpose knife for canoers as well as the camper. With wrist thong. Blade 4 ins. x ½ in. Total length 8½ ins. Weight 6 oz. (68-8103) \$15.95

The Survival Knife is a rugged "man sized" outdoorsman knife developed for armed forces survival requirements. With wrist thong. Tab with stub fastener on holster to prevent loss. Blade 5½ ins. x 1½ ins. Total length 10½ ins. Weight 11 oz. (68-8104) \$27.50

The Folding Knife is a new development of the Belt knife that folds like a pocket knife. Blade Handle Weight (69-8105) \$21.95

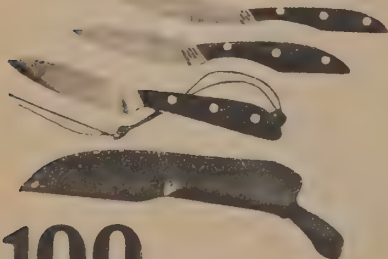

**STRING UNDERWEAR**

Very popular underwear which keeps the body at normal temperature in both hot and cold temperatures by providing an insulating layer of air next the skin. Very comfortable and light. Made in Norway.

Athletic Shirts. Weight 4 oz. (68-7040) \$2.95  
"T" Shirts. Weight 5 oz. (68-7041) \$3.45  
Shorts. Weight 4 oz. (68-7042) \$2.95  
Longs. Weight 8 oz. (68-7043) \$4.95



★ Herter's

If we gave a prize for most-suggested item, we would have to award it to Herter's, the people's choice (maybe 30 suggestions, 15 or so reviews). Everybody says their prices really are low and their quality good on a truly unusual range of products. And Herter's indeed puts out the most entertaining catalog in the business (\$1.00 until you're a regular customer; 656 pp). At mail order distance it's a giggle, all those inflated boasts and fierce gun and trap write-ups and between-the-lines patriotism. We visited their showroom in Minnesota a summer ago, and in the presence of their guards and threatening signs and shoddy goods on display—well, up close we stopped laughing. [By the way, I could see people doing very similar takes on the WHOLE EARTH CATALOG—we pretend to be a consumer service, but it's just a front for fuzzy-headed apologism for dope and sex and subversive activity. No wonder I'm freaky about Herter's. We're sisters under the skin.]

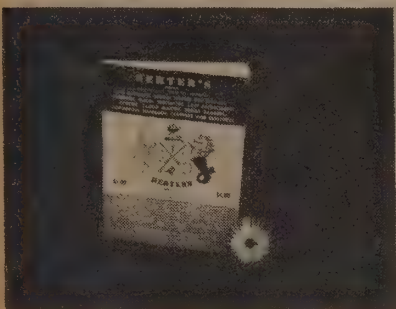

Herter's Catalog 1970; 656 pp.

\$1.00 postpaid

from: Herter's, Inc. Waseca, Minnesota 56093

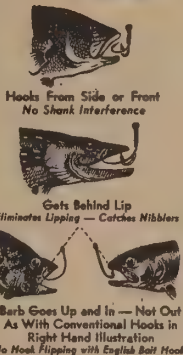

HERTER'S ANCIENT PASSENGER PIGEON DECOYS

Not too long ago the passenger pigeons were very plentiful. A few passenger pigeon decoys hung up in a tree would bring in a flock after flock. The Herter women would go to the decoy tree and pick up the dead pigeons in their aprons and walk back to the house to clean them. Passenger pigeons were nothing special to eat as they were dark fleshed and a little livery but well flavored with onions. They were not too bad especially if you had a lot of children to feed.

These decoys are larger than mourning dove decoys as passengers were about a third larger than a mourning dove and about the size of a western white-winged dove.

These decoys are painted and the leg is mounted in a small piece of high grained black walnut. They make wonderful decorations and are a rare American souvenir.

29-1117 Painted Shpg. wt. 2 lbs. \$4.89

HERTER'S MINNESOTA WHITE OAK WINE BARRELS

Made of first quality Minnesota white oak and waxed inside. These sound, tight barrels are ideal for wine making. They have 6 steel hoops and a bung in the side.

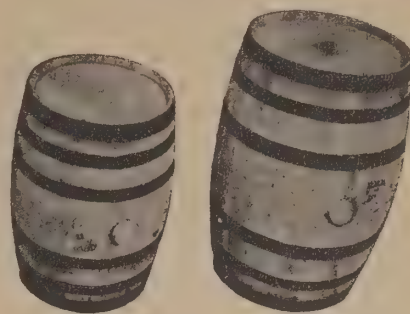

It is recommended to soak these barrels 48 hrs. before using by simply filling with water.

3110 5 gal. Shpg. wt. 15 lbs. \$9.97

3111 10 gal. Shpg. wt. 23 lbs. 11.97

HOW TO GET OUT OF THE RAT RACE AND LIVE ON \$10 A MONTH

This Famous Book Contains Over 200,000 Words, 656 Pages, Over 521 Photos And 304 Illustrations The Equivalent Of Over Three Novels. A Godsend For People Who Are Working At Jobs That They Dislike Under Rat Race Living Conditions That They Dislike. Explains In Detail How To Get Free Land And To Live In Wilderness And Isolated Areas And Actually Make Money Doing It.

AE7C14 Shpg. wt. 2 lbs. \$4.39

HERTER'S BEER YEAST



This powdered lager and ale yeast can be kept about 30 days. One package is enough to start 5 to 10 gallons of beer or ale.

2248 5 grams Shpg. wt. 8 ozs. \$87

Haverhill's

Nifty items. High-rent personal furniture. Haverhill's carries sort of executive tools which because of their general lightness and handiness may be considered nomadic. The main drawback about Haverhill's is their customers, who brag a lot about the nifty little items. 'See. You turn it around and it rubs your back. Then in here it has a caché for pills. I carry it with me all the time now. Why don't you get one? It's only forty-two dollars.'

[Suggested by Alan Kalker]



Haverhill's Catalog free

from: Haverhill's 584 Washington Street San Francisco, CA 94111

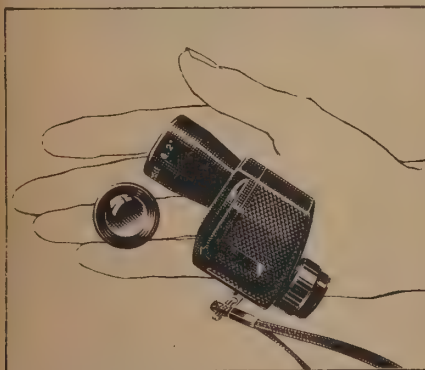

3991 ● M. V. MINISCOPE lets you "hold the world in your palm." It is a monocular of such startling performance that you won't believe it until you see it yourself. With its standard objective it is an 8x, 24mm, wide-angle (8.2°) telescope. For an even larger field, just quick-change objective and you have a 6x, 18mm super-wide angle (11°) scope. As an added bonus, the objectives may be used as 3x and 5x magnifiers of unusual brilliance and crispness. All lenses coated, pinned prisms. Optics of the high quality you have come to expect of the finest Japanese cameras. Only 3 3/4 oz. In a neat, zippered case. A Haverhill's exclusive. \$16.95

8480 ● DYNAMAGIC FLASHLIGHT is a useful pocket-sized light that never runs out of "juice" just when you need it the most, since it generates its own electricity simply by pumping the handle. Just the thing for hunting for fuses etc. Keep one at home and one with camping gear. \$5.95 (shown) 8481 DELUXE MODEL, broad beam. \$9.95

The Smilie Company

For those interested in traditional mule packing and log cabin living—or if you're just hung up on old time type stuff. Everything from sheepherders ovens to genuine heavy iron griddles. They also make those large semi-permanent encampment tents.

[Reviewed by Drew Langsner. Suggested by Jim Wayman]

Catalog \$1.00

from: Smilie Co. 575 Howard Street San Francisco, CA 94105

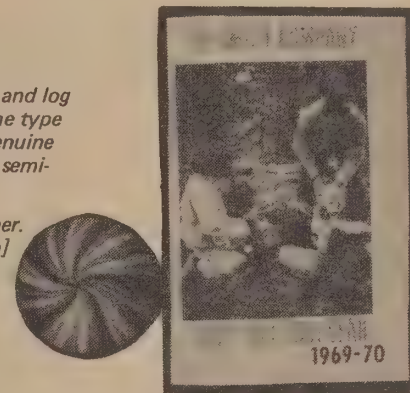

CAMP SEWING KIT - This is a real camper's kit with needles, strong thread, scissors, and thimble all in compact rugged snap covered case. 3 1/2" x 3 1/2" x 1 1/4".

9130 Camp Sewing Kit Wt. 3 1/2 ozs. \$1.25



SHEEPHERDERS WOOD CAMP STOVE - It's the old time Sheepherders Stove, built for hard and long use. Of heavy sheet iron (20 ga.) with 5 piece telescoping pipe (16" lengths) which packs in fire box. Oven size 5" x 8" x 11" with bakepan. Overall size 12" x 9" x 27". Can be packed as top load on pack animal.

- 2-3405 Sheepherders Stove - Wt. 26 lbs. Shipping Weight 35 lbs. . . . . Not PP \$25.00
- 2-3428 4" Stove Pipe Damper . . . Wt. 7 ozs. \$ .85
- 2-3429 5" Stove Pipe Damper . . . Wt. 9 ozs. \$ .95
- 2-3426 4 1/2" Stove Pipe Tent Ring . . . . . \$2.25 Asbestos Wt. 4 ozs.
- 2-3427 5 1/2" Stove Pipe Tent Ring . . . . . \$2.50 Asbestos Wt. 5 ozs.
- 2-3425 6 1/2" Stove Pipe Tent Ring . . . . . \$2.75 Asbestos Wt. 6 ozs.
- 2-3410 Extra Set Telescoping Pipe for Sheepherder Stove - 5 Pieces - Maximum Diameter 5" - Weight 6 lbs. . . . . Not PP. \$6.65

PRESS TOP TINS - These are useful for food storage as they are mouse and squirrel proof and waterproof. Two of these will slide nicely into a mule's pack box. Also with outside painted food can be color-coded. Not for use over fire since these cans have soldered bottoms. Size 9 1/4" square x 13 3/4" high. 7" Dia. opening, includes cover.

3920 Press Top, 5-Gallon Tin . . . Not PP. \$1.95 Weight 2 1/2 lbs. Not Painted



MOISTURE PROOF VINYLITE FOOD BAGS - These bags will actually keep your food dry. Made round and stand up on their flat bottoms, with tie tapes. Of welded tough Vinylite.

No.	Capacity	Size	Wt.	Price
2-6210	1 lb.	2 3/4" Dia. x 9"	1/2 oz.	\$.45
2-6220	2 1/2 lbs.	4 1/2" Dia. x 11"	1 oz.	\$.55
2-6240	5 lbs.	6" Dia. x 12"	2 ozs.	\$.65
2-6260	15 lbs.	9" Dia. x 16"	3 ozs.	\$1.25
2-6261	25 lbs.	9" Dia. x 25"	5 ozs.	\$1.50

JUMBO CAST IRON GRIDDLE - This size for big mulepack parties. 13 1/2" x 25" surface with handles (30" overall).

2-3214 Jumbo Cast Iron Griddle . . . Not PP. \$15.95 Ship. Wt. 28 lbs. Without box. Wt. 25 lbs.



4154 ● AUTO-MINI FOLDING BICYCLE fits into the trunk of even the smallest car. Drive to your favorite cycle spot, park your car, and take off on a scenic bike tour. Takes only a minute to snap up. Same model suits men, women or children thanks to adjustable handle bars and saddle. With lights, generator, 2 brakes, gears, luggage carrier and aluminum wheels. Shiny metal heavily chromed. Red lacquer finish. Shipped freight collect. \$99

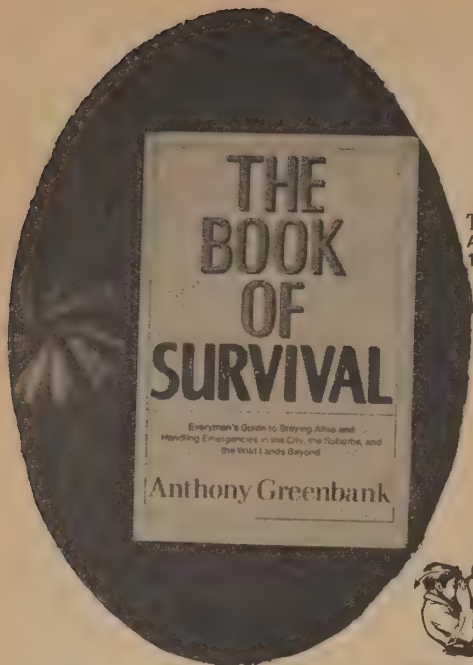

**The Book of Survival**  
Anthony Greenbank  
1967. 223 pp.

**\$5.95** postpaid from:  
Harper and Row  
49 East 33rd Street  
New York, NY 10016

or **WHOLE EARTH CATALOG**

*The Book of Survival will be published in paperback in February, 1970 by New American Library. See January Supplement for price.*

**The Survival Book**  
Paul Nesbitt,  
Alonso Pond,  
William Allen  
1959; 338 pp.

**\$1.95** postpaid

from:  
Funk and Wagnall's  
380 Madison Avenue  
New York, N. Y. 10017

or **WHOLE EARTH CATALOG**

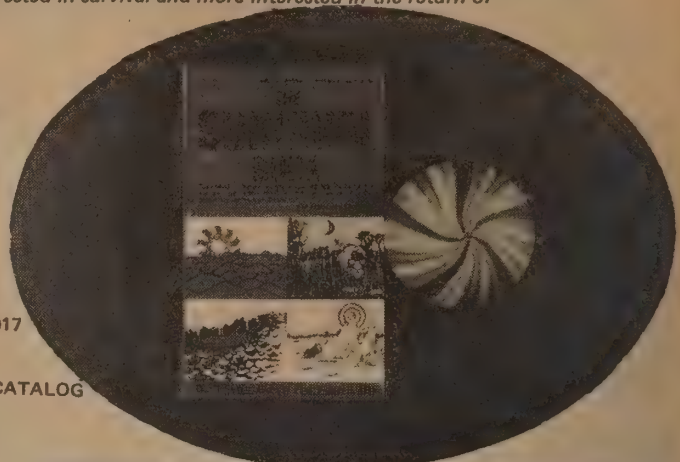

### Innovator

*This publication offers practical information on two strategies of survival if national affairs get funny: hiding, and running.*

*Innovator is published quarterly. Free Trade, a supplement devoted to ads and correspondence, comes out monthly.*

[Suggested by Mu]

**\$1.00** Free Trade for one year  
**\$4.00** Innovator and Free Trade for one year

from:  
Innovator  
Box 34718  
Los Angeles, CA 90034

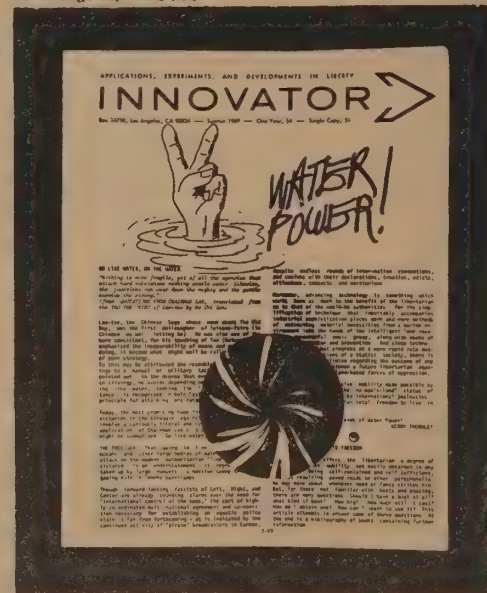

Better buys on houseboats may often be found by shopping, in the 'off season,' at locations where wealthy people congregate. From April until the end of summer, for example, is the ideal houseboat hunting period in and around Miami. This is because many wealthy people buy new houseboats, lose interest in them when the novelty wears off or a new model attracts their fancy, and sell at a sacrifice—a kind of status seeking which works to the advantage of the freedom seeker.

To live with the land means understanding it and the things around you. You must think of yourself as one of the Great Spirit's creatures of the wilderness. The land has no enemies in it. You all share the same earth. You learn to live and blend with nature. You never kill anything that you don't eat. If you follow this way, you will always have food. The wilderness around you is your store house and refrigerator.

As a preference of weapons, I like a .22 bolt action rifle for providing the weekly meat larder with small game. I prefer this to automatic as you are not as inclined to waste shells. When deer or big game hunting, I like a 30-30 for open country and use a shotgun in brush country with slugs or buck shot. Sometimes in the brush country, when deer hunting, I still carry a slingshot for small game. Instead of old auto inner tubes, I use a surgical rubber for the slingshot. The new type of inner tube does not have the stretch that the old post-war tubes had. Many a ruffed grouse, gray squirrel or rabbit has found his way to my table, thanks to the slingshot. Back during the depression—W. P. A. days, there was hardly an Indian working on the road crew that did not carry a slingshot to get a little camp meat.

Noodling is a simple procedure and a great sport. Tie something white and small onto your hand securely and place both hands quietly beneath a fallen log in the water or near a group of rocks. Wait. Soon you will actually see the fish approaching the waving white flag. They will get closer and finally close enough that you can catch them with your bare hands.

## The Book of Survival and The Survival Book

One barometer of people's social confidence level is the sales of books on survival. I can report that sales on *The Survival Book* are booming; it's one of our fastest moving books. What's weird is that it's almost pure romance to buy *The Survival Book*, which is an excellent handbook for Air Force pilots downed in remote regions. The other book we list, *The Book of Survival*, is far more practical and far better organized. The threats it deals with are closer and realer: burning buildings, freaked humans, speeding cars, dogs, floods, electricity, poison—genuine homely hazards. From what we can see, people are less interested in survival and more interested in the return of the frontier or maybe a sudden desert island. Fat chance.

When lying on the ground and being kicked try to keep rolling, shielding parts being kicked with arms. **BUT** always protect head as priority. Clasp base of skull with both hands, bring wrists across ears and side of head and press elbows together. Bring knees up, crossing ankles to save genitals.

In all attacks it pays to shout/gasp/yell more than you need: Feign pain. Especially when on receiving end (lying on ground and being kicked). Attacker may be satisfied sooner when you appear in agony.

### FIGHTING DRUNK

Humor.

If involved in brawl, drunks can offer astoundingly strong grip. Hit hard in stomach and this may make him sick.



Rope climbing using friction knots

### UNCONSCIOUSNESS

Test by touching eyeball gently—a blink means injured is conscious.

Never shout/shake/pummel. Don't try to force down fluids (and never try to give alcohol). If back does not appear broken (see **TOO FAST**)...

1. TURN BODY AND HEAD TO ONE SIDE.
2. CLEAR MOUTH OF DENTURES/VOMIT/DIRT AND CHECK BREATHING.
3. LOOK FOR BLEEDING AND STOP.
4. LOOSEN CLOTHING AND TREAT FOR INJURIES.
5. SEARCH POCKETS FOR IDENTITY—AND NOTICE OF DIABETES, ETC.

Get stretcher/medical help/ambulance.



### EMERGENCY CHILDBIRTH

Happens anytime. Don't panic. Not unique situation. Let nature handle it with you helping it along.

Above all...

1. DON'T PULL BABY OR ITS CORD OR AFTERBIRTH ATTACHED TO OTHER END OF CORD.
2. TIE CORD AS SOON AS BABY IS DELIVERED.
3. CUT CORD ONLY IF NO HELP LIKELY. IF HELP ON WAY, TIE CORD BUT LEAVE AFTERBIRTH ATTACHED.
4. KEEP BABY WARM. PLACE BETWEEN MOTHER'S LEGS..

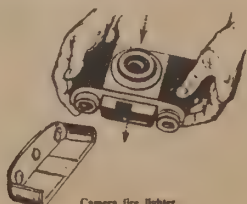

Camera fire lighter

One of the authors once gave a 50-cent Swiss jackknife to a Tuareg noble in the Sahara. Later he received courtesies out of all proportion to the demands of hospitality. Finally the noble explained. "When you first came here you gave me a knife that closes. All my life I have wanted a knife that closes. You are my friend. Anything I have is yours."

### DO'S AND DON'T'S FOR THE TRAVELER IN ARABIAN DESERTS

Here are a few of the most important don't's. In general they apply to the deserts everywhere.

- Don't reprimand an offender in front of other people.
- Don't draw sand pictures or maps with your foot—stoop down and draw with your right hand.
- Don't swear at a native.
- Don't expose the soles of your feet to others. Sit tailor fashion or on your heels.
- Don't ask about a man's wife.
- Don't throw a coin at a man's feet. That is insulting.
- Don't try to gamble. It is forbidden.

And here are a couple of Do's worth remembering.

- Do have patience when dealing with desert people.
- Do act friendly.

### EXPECTED DAYS OF SURVIVAL AT VARIOUS ENVIRONMENTAL TEMPERATURES AND WITH VARYING AMOUNTS OF AVAILABLE WATER

	Max. daily in shade temperature, °F	Available water per man, U.S. quarts					
		0	1	2	4	10	20
NO WALKING	120	2	2	2	2.5	3	4.5
	110	3	3	3.5	4	5	7
	100	5	5.5	6	7	9.5	13.5
	90	7	8	9	10.5	15	23
	80	9	10	11	13	19	29
	70	10	11	12	14	20.5	32
	60	10	11	12	14	21	32
	50	10	11	12	14.5	21	32
WALKING AT NIGHT AND RESTING THEREAFTER	120	1	2	2	2.5	3	
	110	2	2	2.5	3	3.5	
	100	3	3.5	3.5	4.5	5.5	
	90	5	5.5	5.5	6.5	8	
	80	7	7.5	8	9.5	11.5	
	70	7.5	8	9	10.5	13.5	
	60	8	8.5	9	11	14	
	50	8	8.5	9	11	14	

### \* At Home in the Wilderness

Unusual outdoor book, written by Sun Bear, who edits a pan-Indian magazine called *Many Smokes*. His lore is most relevant to North Woods and the Great Basin.

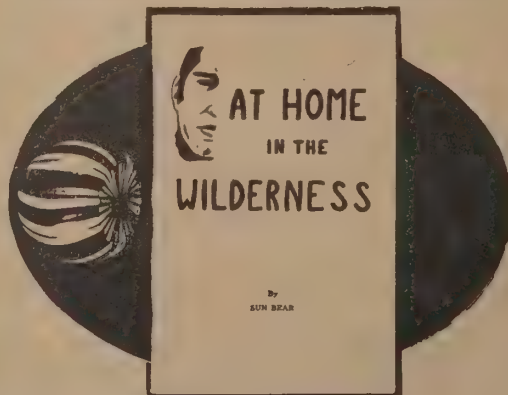

**At Home in the Wilderness**  
Sun Bear  
1968; 90 pp.

**\$3.00** postpaid

from:  
Sun Bear  
P. O. Box 5895—W  
Reno, Nevada 89503

**Horses**

When handling horses there is no substitute for experience, but this book is as close as you can get. In the first 115 pages the author presents encyclopedic information on all phases of horse management. The last fifty pages are devoted to a brief discussion of eastern riding and showing.

[Suggested and reviewed by Michael S. Kaye]

**Horses: Their Selection, Care and Handling**

Margaret Cabell Self  
1943; 170 pp.

**\$5.95** postpaid

from:  
A. S. Barnes & Co.  
Box 421  
Cranbury, N. J. 08512

or **WHOLE EARTH CATALOG**



**I. SELECTION OF THE HORSE**

Familiar breeds of horses, how they came to be developed and for what purposes they may be used—Where to buy your horse—Tests for soundness

**II. SELECTION AND CARE OF EQUIPMENT**

Types of saddles and bridles—Grooming tools and other stable equipment needed—harness—Types of vehicles—Care of tack

**III. THE STABLE**

Location—Materials—Dimensions of stalls—Flooring—Stable accessories—Ventilation and lighting—The tack room—The hay loft—Paddocks and pastures—Converting a garage

**IV. GENERAL CARE**

Principles of feeding and watering—Amounts and kinds of food necessary—Cost—Amount of time needed—Bedding—Grooming—Shoeing—Clipping—Vanning—Methods of-tying

**V. FIRST AID**

Accidents and injuries—Treatment of lameness due to injury—Lameness due to wounds or infections—Lameness due to chronic condition or disease—Wounds—Treatment of common illnesses—For the medicine chest

**VI. HANDLING THE HORSE**

General characteristics and temperament—Fundamental rules for handling and controlling in the stable—How to lead—How to back out of a stall—Working around a kicker—Catching a horse in pasture—Bridling and saddling

**VII. CAUSE AND CONTROL OF VICIES**

Stable Vices: Cribbing—Tearing the blanket—Weaving—Crowding—Kicking in the stall—Backing out of the stall suddenly  
Other vices: Kicking while under the saddle—Kicking while being mounted—Biting another horse—Charging in the pasture—Rearing under the saddle—Bolting—Shying—Refusing to leave his companions, or to leave the stable alone—Eating grass while under the saddle—Shying out at jumps—Getting overexcited at jumps



LEADING A HORSE

With neither bridle nor halter. Grasp the horse's forelock in the right hand and put your left hand on his muzzle over the nostrils. It is the latter which will give control if he tries to pull back or jerk away. Slightly pinching the nose just above the nostrils will distract his attention. With a mean, stubborn animal you may have to pinch hard enough to close the air passage. A horse cannot breathe through his mouth and will soon give up if his wind is cut off.

**Practical Western Training**

In an area where most of the horseshit does not come from the horses, Practical Western Training is a refreshingly useful and sensible book. Dave Jones is a working western horseman and he gives the reader the benefit of years of successful, practical experience. Most important he treads the fine line between senseless counter-productive brutality and letting the horse run the whole show.

[Reviewed by Michael S. Kaye]



Colt backing in draw reins. This is very good, for the pull is low. It's easy for a colt to back if his head is low, almost impossible if he's "star-gazing." Notice that Ken has his weight off the seat, which allows the horse to back fast and straight.

Some guys "knock and spur" a handle on their horses; that's one way. You won't find that kind of stuff in this book. Sure, sometimes you have to get a little rough with a rough horse, and I'll tell you how to do this. But I won't tell you how to beat up a horse.

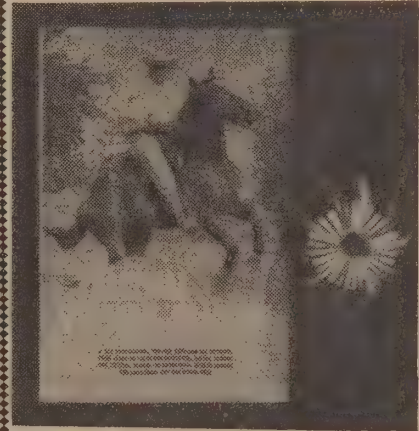

**Practical Western Training**

Dave Jones  
1968; 176 pp.

**\$5.95** postpaid

from:  
Van Nostrand-Reinhold  
450 East 33rd St.  
New York, N. Y. 10001

or **WHOLE EARTH CATALOG**

I think most any trainer can knock and spur a good handle on a colt in thirty days. I can, but I won't. This colt has no place to go but downhill. A horse must want—or at least not be afraid—to work to be any good. Who in the world wants a horse he has to half kill to get him to work?

How can a horse be prevented from running or fighting? Simple. Throw him and tie him down. Show him how helpless he can be made to be. If done correctly, this will work on kickers, buckers, biters, strikers, rearers—you name it.

I won't say that this is effective one hundred per cent of the time—horses amaze me every day. I will say that in my years of training horses I have never seen it fail when done properly.

**King Solomon's Ring**

The classic animal book. Lorenz is a famous student of animal behavior as well as a famous pet-haver.

**King Solomon's Ring: New Light on Animal Ways**

Konrad Z. Lorenz  
1952; 202 pp.

**\$1.95** postpaid

from:  
Apollo Editions  
425 Park Avenue South  
New York, N. Y. 10016

or **WHOLE EARTH CATALOG**



Why has the dog the inhibition against biting his fellow's neck? Why has the raven an inhibition against pecking the eye of his friend? Why has the ring-dove no such "insurance" against murder? A really comprehensive answer to these questions is almost impossible. It would certainly involve a historical explanation of the process by which these inhibitions have been developed in the course of evolution. There is no doubt that they have arisen side by side with the development of the dangerous weapons of the beast of prey. However, it is perfectly obvious why these inhibitions are necessary to all weapon-bearing animals. Should the raven peck, without compunction, at the eye of his nest-mate, his wife or his young, in the same way as he pecks at any other moving and glittering object, there would, by now, be no more ravens in the world. Should a dog or wolf unrestrainedly and unaccountably bite the neck of his pack-mates and actually execute the movement of shaking them to death, then his species also would certainly be exterminated within a short space of time.

The ring-dove does not require such an inhibition since it can only inflict injury to a much lesser degree, while its ability to flee is so well developed that it suffices to protect the bird even against enemies equipped with vastly better weapons. Only under the unnatural conditions of close confinement which deprive the losing dove of the possibility of flight does it become apparent that the ring-dove has no inhibitions which prevent it from injuring or even torturing its own kind.



**First Aid Hints for the Horse Owner**

Anyone owning a horse knows the importance (sometimes immediate importance) of being able to quickly & efficiently check out symptoms. If you can take the British humor, this book is an exceedingly competent guide.

[Suggested and reviewed by Mary McCabe]

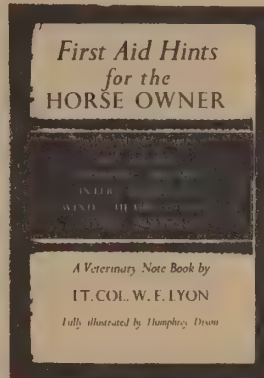

**First Aid Hints for the Horse Owner**  
Lt. Col. W. E. Lyon  
1933, 1950; 151 pp.

Price Unknown

from:  
Blackwell's  
Broad Street  
Oxford, ENGLAND



CLASP TO PREVENT SAND CRACK SPREADING.

**Trout Fishing in America**

There was nothing I could do. I couldn't change a flight of stairs into a creek. The boy walked back to where he came from. The same thing once happened to me. I remember mistaking an old woman for a trout stream in Vermont, and I had to beg her pardon.

"Excuse me," I said. "I thought you were a trout stream."  
"I'm not," she said.

A little way from the shack was an outhouse with its door flung violently open. The inside of the outhouse was exposed like a human face and the outhouse seemed to say, "The old guy who built me crapped in here 9,745 times and he's dead now and I don't want anyone else to touch me. He was a good guy. He built me with loving care. Leave me alone. I'm a monument now to a good ass gone under. There's no mystery here. That's why the door's open. If you have to crap, go in the bushes like the deer."

"Fuck you," I said to the outhouse. "All I want is a ride down the river."

**Trout Fishing in America**

Richard Brautigan  
1967; 112 pp.

**\$1.95** postpaid

from:  
City Lights Books  
1562 Grant Avenue  
San Francisco, CA 94133

or **WHOLE EARTH CATALOG**



**Sacred**

**To the Memory**

of

**John Talbot**

**Who at the Age of Eighteen**

**Had His Ass Shot Off**

**In a Honky-Tonk**

**November 1, 1936**

**This Mayonnaise Jar**

**With Wilted Flowers In It**

**Was Left Here Six Months Ago**

**By His Sister**

**Who Is In**

**The Crazy Place Now.**

## Motor Trend Repair Manual

This manual is intended to be an introduction to automobile mechanics and the more fear-some professional shop manuals. It contains about all the amateur mechanic needs to know in order to diagnose, repair, and maintain domestic cars and VW 1954-1965. It is assumed that the mechanic has no experience at all. All major assemblies are well illustrated and explained both in principle and specifically, with note made of quirks found in certain models. There are chapters or remarks on tools needed and how to use them, working safely, junk yard technique, on-the-road repairs, and general money saving. There is a very good chapter on logical trouble shooting. "If this is wrong, try this first, this second, etc." Included is most likely diagnosis and prescription. Common repairs like 'putting in new points' are covered neatly. Major jobs are presented so that the amateur mechanic can get most of the work done before calling in expensive expert help. It is clearly stated when to give up, and what not to attempt without expertise. They even tell you how much you will save, and how long it will take. This is a great book for that person trying to keep the oldie going and/or who wants to understand cars in general. It fits girls too. Well worth the money.

[Suggested and reviewed by J. Baldwin]

Motor Trend Basic Auto Repair Manual  
1968; 384 pp.

\$3.95 postpaid

from:  
Petersen Publishing Company  
8490 Sunset Blvd.  
Los Angeles, CA 90069

or WHOLE EARTH CATALOG

After all the oil is poured in, the car should be driven with wide-open throttle under heavy load, such as climbing a steep hill at about 50 mph. If no hills are available, short acceleration bursts from about 30 mph up to 60 will do the job. This 'blowing out' is especially effective on a car that has been driven around town. Don't blow out the engine after the tune-up, do it before. New spark plugs can be fouled by this procedure so that they must be replaced.

It's a good idea to use tune-up oil on every car to clean out deposits in the cylinders. The oil is poured into the carburetor air intake with the engine at a fast idle. If you can keep the engine running by opening the throttle wide but keep the rpm down to an idle by pouring the oil faster, you know the oil is doing its job properly.

All yard operators strip some fast-moving or valuable parts from a wreck and stock them for resale. Examples would be undamaged components from an air-conditioning system; batteries, tires and even engines and transmissions from late-model wrecks; and intact sheetmetal parts like hoods, trunk lids, bumpers and grilles. The biggest operators are tied together by a regional teletype system so that if one doesn't have the part, it can be determined in seconds whether anybody has it. In fact, if your needs are put on teletype and no one has the part, odds are that in a few days an accident will happen that will enable your order to be filled. A late model wreck, totalled from an insurance standpoint is by no means 'junk.' It will return at least \$500 if properly salvaged. Then, there are still countless rural yards that fill a cow pasture with derelict cars and let you prowling around until you find the part you want. These are self-service stores in the true sense because you do your own dismantling, but it's a fascinating way to spend a Saturday afternoon.

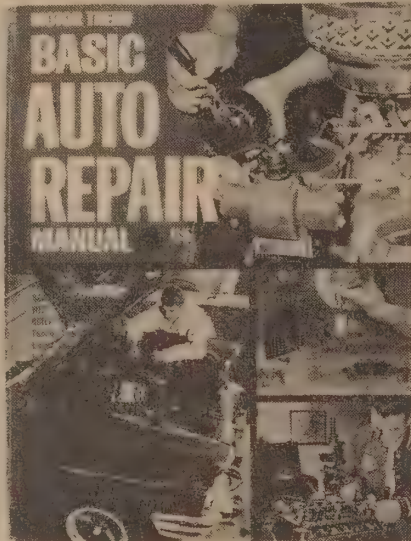

## Volkswagen Technical Manual

There's unusual agreement among all the mechanics we've talked to that this is the best book on VW's. It's good prevention against getting burned by the Volkswagen agencies in Reno and Oklahoma City (name your favorite villain; those are mine) when a dismaying noise starts following you down the road and your trip shifts from 400 miles a day to nothing a week.

[Suggested by Don Burns]

Volkswagen  
Technical Manual  
Henry Elfrink  
1964; 256 pp.

from:  
Henry Elfrink  
Automotive  
P. O. Box 20715  
Los Angeles, CA 90006

\$3.50 postpaid

or WHOLE  
EARTH  
CATALOG

The VW has often been compared to that 'other universal car' of many years ago: the model T Ford of which more than 15 million were built. There is a germ of truth in this comparison; both cars were built for the masses by geniuses in their field, but whereas the old model T was basically a simple car which could be repaired, so to speak by anyone with a screw driver and a pair of pliers, the VW is a high precision piece of machinery. The VW, although simple in its basic conception, actually in many ways is a subtle mechanism, as will be readily apparent after the following pages are perused.

The methods employed to boost the power output of the VW engine follow the usual speed-tuning pattern: dual carburetors, supercharging, high compression cylinderheads, high-compression pistons, long-stroke crankshafts, special camshafts, extra large cylinders and the various possible combinations of these methods.

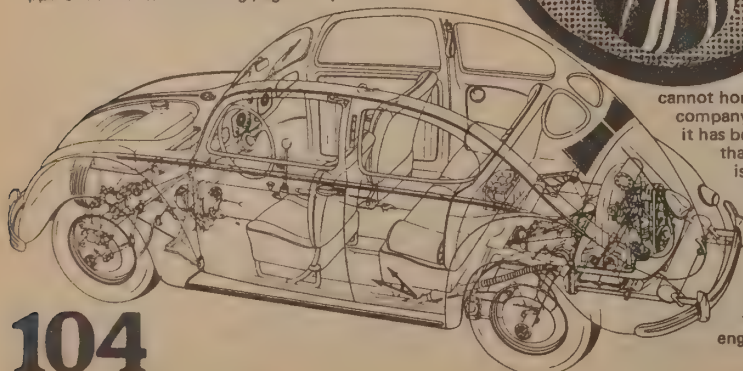
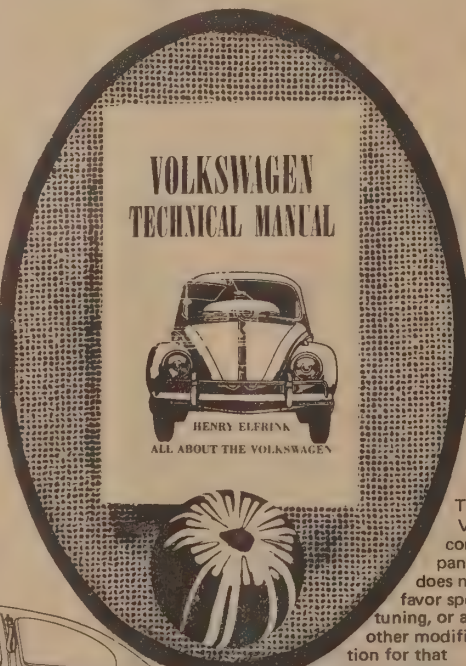

104

The VW company does not favor speed tuning, or any other modification for that matter. Although we cannot honestly blame the company for holding this view, it has been our experience that a mild power boost is not harmful, providing the car is sensibly driven. The VW engine—especially the latest type—is very rugged, and it has a greater built-in reserve strength than the majority of small engines built today.

**TIRE CARE.** the most important as well as the easiest single step in tire care is maintaining proper inflation. Pressures specified by Detroit in owner's manuals, ranging usually from 24 to 28 psi for normal driving, tend to favor comfort and quiet over tire life. A trained, conscientious tire salesman will more likely recommend 30 psi at all 4 wheels for maximum tire life.

Address requests for automotive catalogs to:

Sears Roebuck and Co.  
Local catalog order center

Montgomery Ward and Co.  
Local catalog order center

Spiegel Inc.  
Chicago, Illinois 60609

J. C. Whitney & Co.  
1917 Archer Ave.  
Chicago, Illinois 60616

Honest Charley, Inc.  
Honest St. at North Highway 11  
Chattanooga, Tenn. 37421



## Truck Repair Manual

If you have a truck, chances are marvelous you spend a fair amount of your time under it or in the front end of it. Judicious use of this book might save you some down-time. It covers the gamut of trucks and tractors, 1960-69, and has better than usual illustrations of how to get at what you're working on.

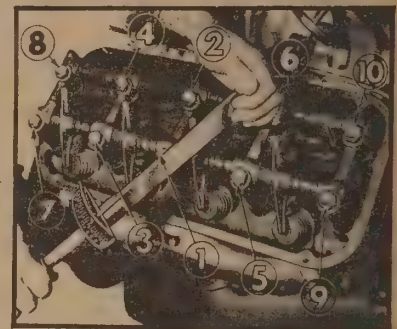

Fig. 1 Cylinder head tightening sequence Double rocker arm V8 engine

Motor's Truck Repair Manual  
1969; 1154 pp.

\$14.00 postpaid

from:  
Motor Book Department  
250 West 55th Street  
New York, N. Y. 10019

or WHOLE EARTH CATALOG

## J. C. Whitney Automotive Accessories & Parts

A really great catalog of car parts, not all of them above suspicion as far as usefulness goes, but on the other hand very complete and especially good for older cars, is the J. C. Whitney Catalog. They stock parts for such things as model A Fords and Borgwards, Jeeps and VWs, and offer used parts.

[Suggested and reviewed by J. Baldwin]

Catalog from:  
free J. C. Whitney & Company  
1917-19 Archer Avenue  
Chicago, Illinois 60616

Convert Your Turn Signals to  
Emergency Warning Lights With  
Deluxe 4-WAY FLASHER  
for All Cars and Light Trucks

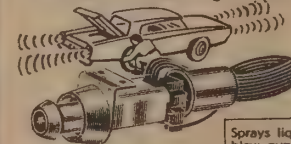

With Illuminated Pull Switch  
Heavy duty flashing system that operates as an independent circuit—cannot overload

car's existing signal light system. Modern design conforms to, or exceeds all SAE standards and state requirements. Features are:  
• Modern pull switch with flashing pilot light—audible click puts unit in operation.  
• Rugged, unbreakable mounting bracket that can be easily installed under dash.  
• Heavy duty plug-in flasher and fuse.  
• Self-insulating quick crimp connectors eliminate cutting, splicing, stripping and taping of wiring system.

Complete instructions included. Shpg. wt. 12 oz.  
75-574—6 Volt. . . . . Each \$4.65  
18-141—12 Volt. . . . . Each \$4.65



3-in-1 Sand  
Blast, Spray  
& Blow Gun

For sand blasting small parts—removing rust and scale—also etching glass and metal.

Sprays liquids, oils, anything that pours. Use as blow gun for cleaning and drying parts. Operates off any air compressor. Operates on 60 to 150 lb. air pressure. With quart container, instructions. (Air hose not included.)  
74-5740—Shpg. wt. 2 lb. . . . . Each \$5.98

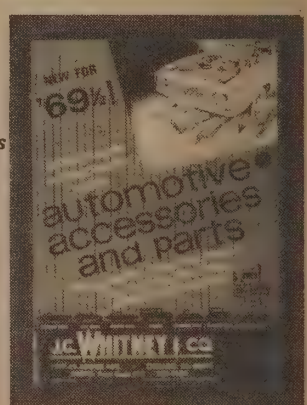

"Make Your Own Gaskets"  
Sheet Gasket Materials  
CORK-FIBRE-ASBESTOS

CORK GASKET SHEETS. Finest clean granulated cork and special treated binder are used in making this sheet cork resilient, flexible and strong.  
Shpg. wt. 8 oz.  
34-094—12"x36"x1/16" . . . . . Each 59c  
34-095—12"x36"x3/32" . . . . . Each 79c  
FIBER GASKET SHEETS. Seals effectively under medium bolt pressures. Recommended for oil pans, air cleaners, radiator core gaskets and vibration dampeners. Shpg. wt. 6 oz.  
34-096—12"x36"x1/32" . . . . . Each 49c  
34-097—12"x36"x1/64" . . . . . Each 29c  
ASBESTOS GASKET SHEETS. Used where extreme heat occurs, such as exhaust manifolds, headers, pipes, etc. Shpg. wt. 2 lbs.  
34-098—10"x40"x1/32" . . . . . Each \$1.19  
34-099—10"x40"x1/16" . . . . . Each 1.89

## Roadside Camping

The best roadside tent by far is the Thermos POPTENT(R), a dome shaped affair that erects in about one minute without ropes, poles, or stakes and will withstand bad weather remarkably well. Comes in two sizes with sewn in floor, screen door and window. Hexagonal floor about 6 1/2 feet across the flats sleeping two and a child, and a larger one about 8 1/2 feet and 6 feet high that will sleep four but with less wind stability. The smaller one is best, folding up into a bag 5 inches diameter and two feet long weighs 13 lbs. Prices vary from store to store, but expect to pay about \$60 for the small one; \$90 for the big one. Don't pay more. Cut urethane foam 2" thick to fit the floor and you have a good camp for a small car or motorcycle.



A really good toilet for minibuses and vans or even cabins is the PORTA POTTI. It does its job as advertised for \$109.00 and there is no installation chore. from ALLIED TRAILER SUPPLY STORES. The same manufacturer makes nice plastic sinks for \$7.50.

Honda has a new 300 watt generator big enough for lighting and small appliances. It's really quiet, you can talk in normal voice with it running on your table. \$185.00. They make a very nice larger one too that is exceptionally easy to operate and though it isn't as quiet as the small one, it still is remarkably quiet. 1500 watts will run Skilsaws and pumps. They are reputed to last an exceptionally long time too.

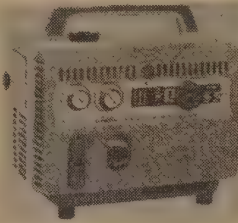

For heating a camper bus or tent there is a small but good silent heater that makes no fumes called the Therm'x. They are safe and they do their job well, but use special fuel that's too expensive for weeks or months. For that job the same company makes excellent propane catalytic heaters for about \$75. The small Therm'x is about \$20 at most camping stores.



### "ADVENTURER"— #30 THERM'X SAFETY HEATER.

Made of sturdy, lightweight anodized aluminum... no rusting! Our most popular model heater for sportsmen and general use. Ideal for hunting, fishing, camping, small trailers, boats, cabins, camper units, station wagons, planes, engine heating and hundreds of other uses. Operates up to 24 hours on a filling of white gas, campstove fuel or Thermasol fuel. Minimum 3,000 BTU output; 9 1/2" high; 8" dia.; wt. 3 lbs. Color, Hunters Red and Ivory. Suggested retail only \$27.95.



CLEAN BURNING

Thermos makes camp stoves that can burn any kind of gas. But if the pumping and hissing bit is a drag to you, look at one of the many bottle gas stoves. Some of the new ones come with a refillable little propane tank; are simple, silent, and safer. These cost about \$30.00 at mountain climbing shops and trailer and boat supply stores. The various brands each have their own advantages, but get one that can use the refillable bottle. [Also bear in mind that dead wood is flammable and free and aesthetic.—SB]

Good equipment costs more, but in nomadic living it is a particular bitch to have devices that don't really do the job bugging you every day. This is especially true of stoves.

Beware of articles made for use in trailers and boats that are "traditional." Often in the past, trailer users have tended to be conservative, and so they have resisted advanced design. There are many pieces of trailer and boat equipment that are just plain silly. Think about it. Travel light.

If you're building a camper bus or converting a truck or just squatting, a gold mine of supplies and parts is the Allied Trail Supply Master Catalog. \$3.00 from ATS PO Box 806 Moun View Calif. 94040. It contains a truly amazing array of things that might be needed in nomadic living (and many that are not) including electrical and sanitation equipment, water purifiers, trailer hitches, lights, fridges, jacks, window and vent hardware, etc. As with most things, it's better to buy it at the store rather than out of the catalog.

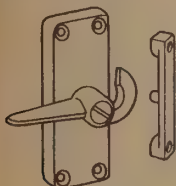

Latch Set Surface Mount w/side strike for sliding screens and windows.



Another good place to find nomad equipment is at the larger marine supply houses. The stuff made for boats will often adapt to land use and is likely to be of better quality. Prices are likely to be higher. Marine catalogs also list an impressive variety of pulleys, cable and rope, eyebolts, caulking compounds, and other nautical stuff that can be useful.

If you are building your own truck body, round off the front corners of all surfaces to a radius of at least 8 inches. This radius will give the least possible air drag (and consequently the best gas mileage) to a basically rectangular shape. You can make the edges of the body curved easily from sheet metal or masonite and fashion the corners from fiberglass over carved styrofoam. Funky log cabins on wheels are users.



pop tent

Camper trucks and busses can be made a lot more comfortable to ride in by replacing the seats with good quality bucket seats out of cars. Most junk yards charge outrageous prices for buckets, but one of the very best seats is from a Renault R8 or 10. These cost as little as \$25 a pair and make a big difference. Get them tracks and all.

Good sunglasses can greatly reduce fatigue and headaches and also save your eyes for night driving. RayBan with g-15 gray lenses take out most of the ultraviolet and infrared rays, but pass most of the light for less eyestrain. They also don't distort colors which is nice for color freaks. These cost about \$12, but are sturdy shock resistant ground glass with no distortion. They also come prescription.

For those of you with money, International makes an aluminum bread truck with power steering and brakes, automatic transmission and V8 engine for about \$4500.

The new model Ford Econoline Bus is by far the biggest bus inside, if that's a travel mode that tempts you. They aren't too good on traction so order "positraction" rear axle. Smaller American bus engines eat about the same as VW, have more power. In all house cars, try to build as light as you can and keep the weight low and distributed evenly. You can have it funky if necessary, but it needn't be ridiculous to drive if you spend a little time designing it.

Cortez is the best large bus type camping rig. It is a lot lower, easier to drive and generally nicer due to having front wheel drive. Used ones are beginning to be seen.

Used or new pickup campers should be on a heavy duty pickup with heavy tires and cooling system. Four wheel drive machines are heavy on gas and expensive to fix. Think if you really need one. "Positraction" rear end on normal pickup is good compromise.

Half ton pickups are really too light for camper rigs.

There are campground guides that list all commercial and State and National park camps. A good one is Rand McNally. The new one appears at larger newsstands about March. There are trailer parks guides too, and mobile home park guides. WOODALL Publishing Co., 500 Hyacinth Pl. Highland Park Illinois 60035 has these for \$3.95 each. [Trespassing is free, aesthetic, and private. Just leave no trace, and the landowner will be friendly to the next guy.—SB]

State electric companies often have camps too at their hydroelectric lakes. Ask them.

If you pull off the road to sleep, if you leave your parking lights on, the police will be less inclined to stop and investigate you. In some states it is illegal to camp along a road but these laws are in the process of change. Back roads are best, but you always run a risk of being yahooped in the rougher parts of the country. In big cities, all night gas stations will often allow you to park in their station to sleep if you buy some gas.

Light tight window covers enable house cars to stay on city streets without police harassment. They think you aren't at home if there are no lights and no neighbor complains. One way is make lids from cardboard instead of having curtains.

J. Baldwin  
Pacific High School  
Saratoga, CA

## Airstream Travel Trailer

No argument; Airstream is the best travel trailer there is—lightest, most beautiful, best designed. It's built like an airplane—monocoque—the skin is the structure, and so it's free of corners inside and out. A pleasure to inhabit. However it's also more expensive than other trailers. If you buy in August, when the sales on this year's models start, you can save \$1,000 or so. Also used Airstreams are worth considering. I & wife live in a 22-footer and prefer it to house, apartment, or tipi. On the road last summer it took 20 minutes to have a dome at Libre.

For nearest Airstream dealer consult:

Airstream  
107 Church Street  
Jackson Center, Ohio 45334  
15939 Piuma Avenue  
Cerritos, CA 90701

Sample prices:

'69	23 ft.	\$6500
'68	24 ft.	\$4900
'63	19 ft.	\$2700
'63	16 ft.	\$2100



## BMW Motorcycle

BMW motorcycles—as far as quality there is not another vehicle on the road that can touch them. Mine is 10 years old and has 143,000 miles on it. Last year I loaded it up with 430 pounds of people, camping gear and luggage and drove to Maine and then went 50 miles into the wilderness. I figure she's good for another 10/143,000. They are a bit expensive but worth every penny. If you're going to go Nomadic, on or off the road, you might as well go all the way. It's the only way to travel. Western distributor is Flander Co., 200 West Walnut Street, Pasadena, CA 91103. Eastern Distributor & sole importer is Butler & Smith, 160 West 83rd Street, N. Y., N. Y. 10024.

[Suggested and reviewed by Larry Kafka]

## Jawa Motorcycle

I was glad to see the BMW mentioned in the Supplement, as bikes are good tools with lots of mythic freedom meanings for most Americans; and for those who are still into the internal combustion reciprocating life style, they have the extra advantage of being: smelly, noisy, sexy, and fast.

I'd like to mention the Jawa, which is at the other end of the scale from the BMW and might be of more interest to rural/community people.

The Jawa is a 2-stroke 125-300 cc lightweight made in Czechoslovakia. Parts are easy to get in the East (a problem in the West) and the bike is dirt cheap to buy and run. Prices run about \$150-\$200 below Italian and Japanese machinery.

But the best thing about the Jawa is that you don't need many parts. The bike was designed to be, and is the staple transportation device of the Communist world. It's simple, slow, reliable and strong.

Like the BMW, the Jawa is an old-fashioned "backwards" machine—unchanged since 1954. The engine is a long stroke, piston port, plain bearing low RPM single (except for the 350 twin), all of which means high torque at low speeds. It's a thumper, a tractor.

The BMW is a great road bike but as soon as you take it in the dirt you're in trouble. With the Jawa, it's the other way around. It'll shake the shit out of you on a long trip, but kick it into low and stand up on the pegs and you can chomp through anything. I like to ride mine in the sand and mud, and I'm sure I could plow with it.

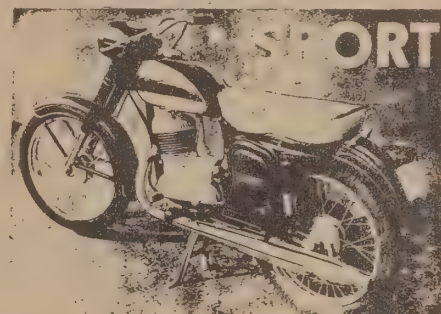

I bought my new 1969 for \$420! Old ones are even cheaper, as they start to rust before you even get them home. Like an East European drip dry suit, it wilts right away but wears forever. This seems like a good cheap draft horse for a community, as you can carry a lot of stuff on a bike after you get used to it, and also hook up a small trailer. I cruise Manhattan looking for firewood on mine.

Check any bike shop in the east or AMERICAN JAWA LTD. 38-15 Greenpoint Avenue, Long Island City, N. Y. 11101.

[Suggested and reviewed by Terry Bisson]

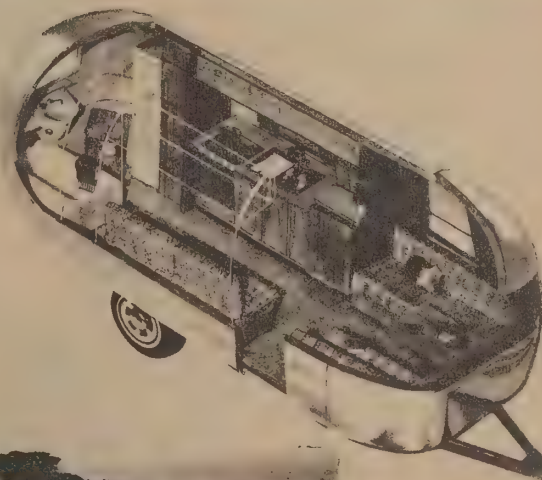

★ **Piloting, Seamanship and Small Boat Handling**

The standard text for U. S. Power Squadrons and U. S. C. G. Auxiliary instruction classes for 47 years. Okay. The "Bible of Boating." Nope. Here's the book for powercraft freaks who dig performance of the machine or crew and craft etiquette. But, heigh-ho the sailing man? And half the chapters must be for people over fifty (what to wear, which flag you fly when, rules aboard, rules ashore). Generally, the text is wordy, and rambles, and alas, makes for dull reading. But wait! What's this? Ten beautiful chapters, on  
Weather  
Compass (2)  
Charts  
Aids to Navigation (2)  
Piloting (3)  
GPO and other maritime publications.

They're packed with the what it is, how to do it and why. How'd that stuff get in here? Yeah, buy the book. But if you put it in the water, it'll sink.

(By the way, U. S. C. G. classes on small boat handling are free; contact your nearest).

[Reviewed by Don Gerrard]

**Piloting, Seamanship and Small Boat Handling**

1969-70 ed. 690 pp; 1000 illus.  
Comprehensive index  
Annually revised

**\$7.95** postpaid

or WHOLE EARTH CATALOG

from:  
Motor Boating  
959 Eighth Avenue  
New York, N. Y. 10019

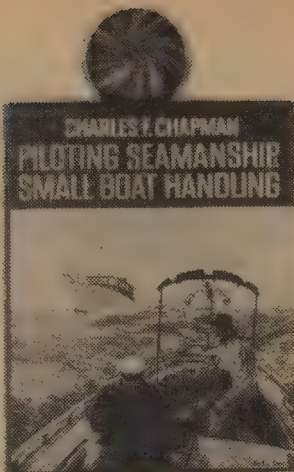

Do not allow your boat to get close to the top of a crest. She might be hurled over the crest and pitch-poled into the trough below.

**Boat Owners Guide**

Published yearly in the winter, this guide gives the full range of what's available in boats, what's new, what prices are, and where to order.

**Boat Owners Guide**  
1969; 320 pp.

**\$1.95** postpaid (\$1.50 more outside U. S.)

from:  
Yachting Publishing Corporation  
50 West 40th Street  
New York, N. Y. 10036

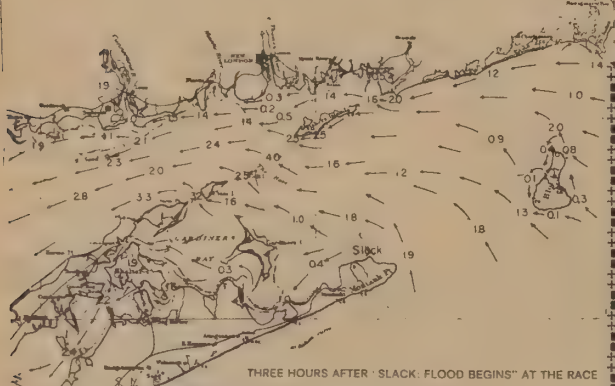

THREE HOURS AFTER "SLACK FLOOD BEGINS" AT THE RACE  
Tidal Current Charts are published for certain major bodies of water. Each is a set of 12 small-scale chartlets whose currents existing at hourly intervals throughout a complete cycle of flood and ebb.

**American Practical Navigator — Bowditch**

There's an episode in Kenneth Roberts' Lydia Bailey where Albion Townsend, having helped lick Napoleon in Haiti, is sailing across the Atlantic with his common-law bride, Lydia, and they're out on deck a lot at night doing sex with Bowditch's book in hand, teaching each other navigation.

This book is big, probably lots more than you care to know about navigation, but it's authoritative, THE word, and it's cheap. Dating origins back to 1799, it has romantic associations to go with its practical lore.

**American Practical Navigator—An Epitome of Navigation**  
Nathaniel Bowditch & U.S. Navy Hydrographic Office  
1966; 1524 pp.

**\$7.00** postpaid

from:  
U.S. Govt. Printing Office Bookstore  
710 North Capitol Street  
Washington, D. C. 20402

U.S. Govt. Printing Office Bookstore  
Rm. 1463, 14th Floor  
Federal Office Building  
219 S. Dearborn Street  
Chicago, Ill. 60604

U.S. Govt. Printing Office Bookstore  
Rm. 135, Federal Building  
601 East 12th Street  
Kansas City, Missouri 64106

U.S. Govt. Printing Office Bookstore  
Federal Building  
450 Golden Gate Avenue  
Rm. 1023, Box 36104  
San Francisco, CA 94102

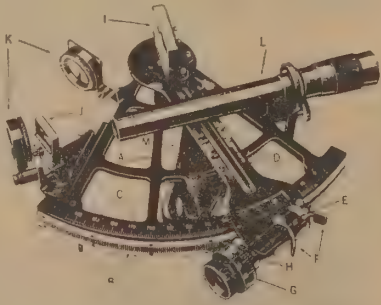

U. S. Navy standard meridian drum sextant

If the craft is to proceed out of sight of land for more than short intervals, celestial navigation equipment should be carried. This includes a sextant, an accurate time-piece, an almanac, sight reduction tables, and perhaps a star finder.

**Sailing Illustrated**

This is a little book with a lot of pictures and an unusually useful layout. It's a nice job of information packing with easy retrieval designed in.

[Suggested by Don Gerard]

**Sailing Illustrated**  
Patrick M. Royce  
1956 . . . 1968; 352 pp.

**\$4.15** postpaid

from:  
Royce Publications  
Box 1967  
Newport Beach, CA 92663

or WHOLE EARTH CATALOG

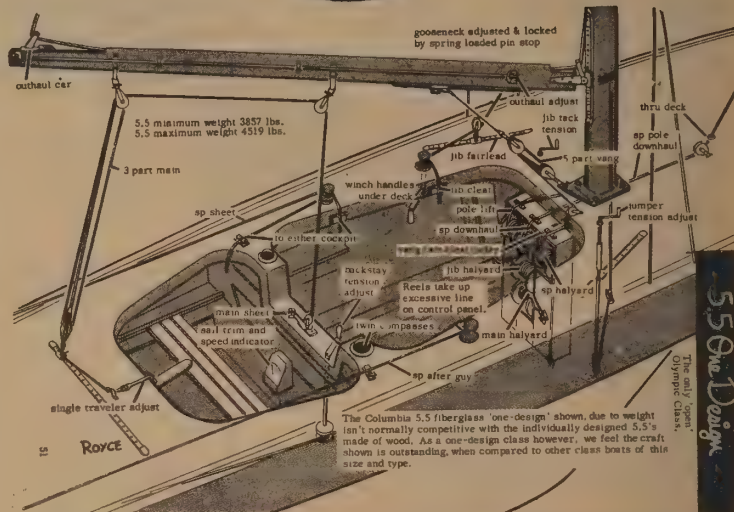
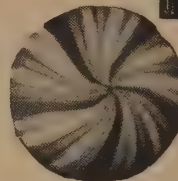
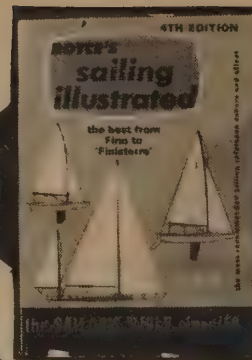

5.5 One-Design  
The only "one-design" Olympic Class.

★ **Skin and Scuba Diving**

Don't expect to read this book and start scuba diving in a month or so. Scuba diving is fun and rewarding sport. But without proper training, it is very dangerous.

This book has grown in time along with the sport of scuba diving. Now in its newest edition, it is more complete than any other book ever written on this subject by anyone. So if you're interested or planning to be involved in this art, you would be best to buy this book; if you don't get it now, your instructor will tell you to later.

[Reviewed by Jay Bonner.  
Suggested by Jack O'Neill]

**The New Science of Skin and Scuba Diving**  
1957 . . . 1968; 224 pp.

**\$2.45** postpaid

from:  
Association Press  
291 Broadway  
New York, N. Y. 10007

or WHOLE EARTH CATALOG



★ **Handy Medical Guide for Seafarers**

This here is a handy medical guide for seafarers.

**Handy Medical Guide for Seafarers**  
R. W. Scott  
1969; 86 pp.

**\$3.85** postpaid

from:  
International Marine Publications  
Camden, Maine 04843

or WHOLE EARTH CATALOG

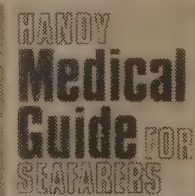

★ **Ocean Living**

For those with sea-going commune or escape-and-evasion fantasies, this newsletter is right in there.

[Suggested by Roberta Becker Marshall]

**Ocean Living**  
William Taylor, ed. from:  
Ocean Living  
Box 17463  
Los Angeles, CA 90017  
**\$1** for 10 issues

**Stick and Rudder**

Subtitle: 'An Explanation of the Art of Flying.' This book was written in 1944 and is still, I understand, the basic flying book. Writing, illustration, comprehensiveness—it's a full-throated classic. I've never flown a plane, but I've flown other stuff, and every page glimmers with useful hints for every kind of flight. Maybe some Sufi pilot would like to do an allegorical review of this profound book.

**Stick and Rudder**  
Wolfgang Langewiesche  
1944; 389 pp.

**\$8.95** postpaid

from:  
McGraw-Hill Book Co.  
East:  
Princeton Road  
Hightstown, N.J. 08520  
Mid-continent:  
Manchester Road  
Manchester, Mo. 63062  
West:  
8171 Redwood Highway  
Novato, CA 94947

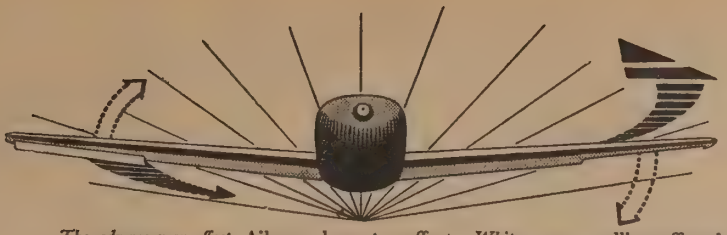

The adverse yaw effect. Ailerons have two effects. White arrows: rolling effect is what pilot wants. Black arrows: yawing effect is an undesired by-product of rolling effect. Here, the pilot banks to (his) left, presumably in order to turn to the left, but the airplane at the same time yaws to (pilot's) right. That's why this yaw effect is called "adverse." Pilot must kill this effect by using rudder.

Hence the Angle of Attack cannot be seen simply by looking out the window; in fact, it cannot be seen at all! For remember, Angle of Attack is the angle at which the wing meets the air—and we can't see air. That is perhaps largely why flying is so much of an art. In baseball the batter keeps his eye on the ball that he is going to hit. Flying is the art of batting the air down with our wings; but in flying, our trouble is that we can't see the air; hence we often fail to hit it right, and hence so many of us break our necks.

Take your hands off a good airplane's stick, and it will do a good job of flying all by itself. Take your feet off its rudder as well, and many airplanes will even then do a fair job. The airplane has a built-in will of its own, and generally speaking it wants to do whatever is necessary to maintain healthy flight.

In actual practice most airplanes have a tendency to hunt. This means that with the controls released, the ship will not fly at constant speed but will oscillate up and down, now dropping its nose, building up speed, diving for perhaps 10, 20, 30 seconds. Then, with its essential stability and better self asserting itself, it will catch itself, raise its nose, try to get rid of its excess speed, and go into a climb. In this climb, a bit too much speed is lost, and the ship noses down again, to repeat the process.

If an untutored person tries to fly an airplane and uses the controls in the manner that seems most "natural" to him, responding most energetically and most quickly to those disturbances that "naturally" impinge most sharply on his consciousness, the flight will almost certainly end in a spiral dive and a crash.

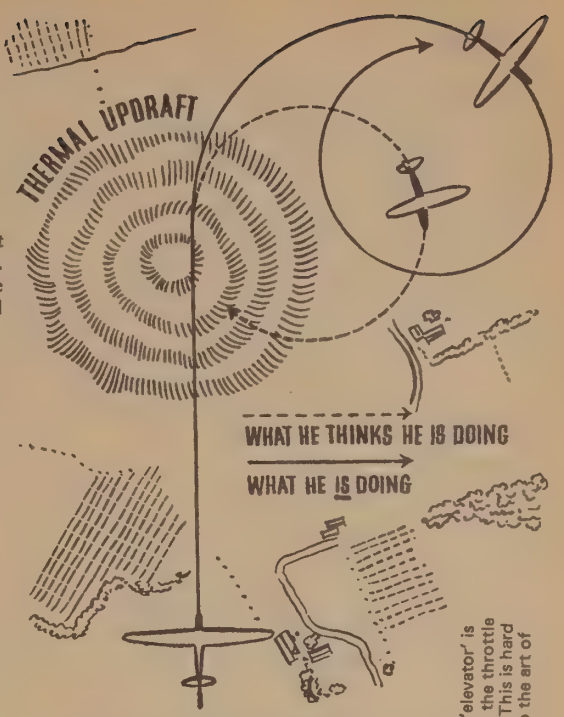

As you approach the ground you must keep your vision relaxed and look all around; you must take in the whole scenery, the perspective of the hangars on the side of the field and the other airplanes on the field, the parked automobiles, the trees, the telegraph poles all around, the grass, the horizon; for it is from the perspective and apparent motion of such things that you will get a vivid perception of your height; and a staring eye will not see what matters. When you get tense, you will almost certainly stare; approaching the ground, most students do get tense; that is largely why the landing is so difficult for most beginners.

Stick and Throttle. The so-called 'elevator' is really the airplane's speed control, the throttle is really its up-and-down control. This is hard to believe but is one of the keys to the art of piloting.

or **WHOLE EARTH CATALOG**

On wings it is safe to be high, dangerous to be low; safe to go fast, dangerous to go slow. Generally speaking, if you want the airplane to go up, you point its nose up; but point its nose up a little too much, and you go down in a stall or a spin. In landing an airplane, to make it sink down on the runway and stay down, you move the controls much as for an extreme upward zoom. In the glide, if you want to descend more steeply, you point your airplane's nose down less steeply; if you want to descend less steeply, you point the airplane's nose down more steeply! And—most spectacular contrariness of all—in emergencies, when the airplane is sinking toward the ground in a 'mush' or falling in a stall or a spin, and you are afraid of crashing into the ground, the only way to keep it from crashing is to point its nose down and dive at the ground, as if you wanted to crash!

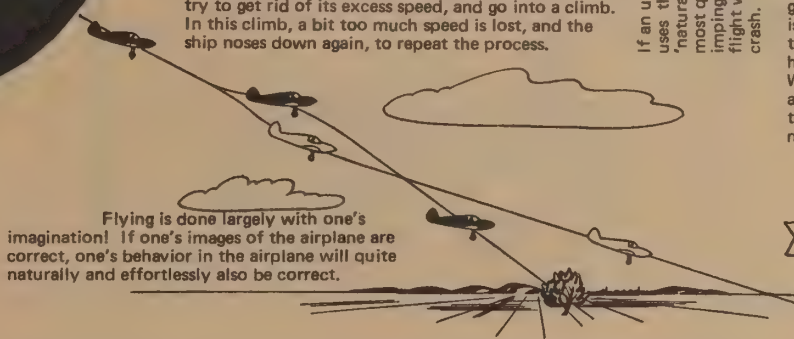

The pitfall of glide control: when doing the right thing, you get the wrong result first, the right result only later. Nosing the airplane up steepens the descent, but first causes a temporary ballooning. Nosing the airplane down shallows the descent, but first causes an extra sink. Be patient for a few seconds.

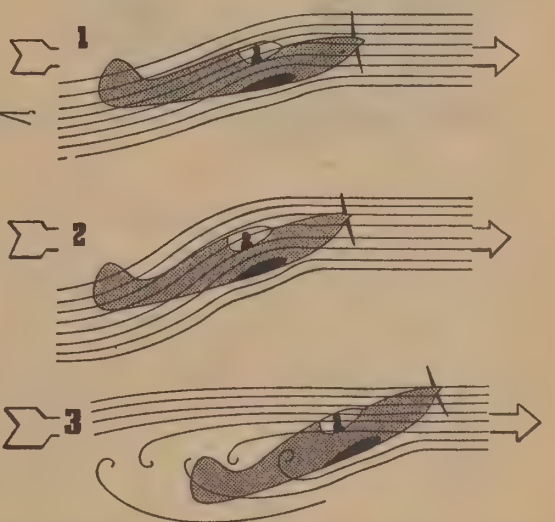

An ordinary stall occurs simply because the pilot forces the airplane as a whole to an excessive Angle of Attack. The pilot is trying to lift his airplane by pulling the stick back. He overdoes it, and thus he drops it.

**Private Pilot's Handbook**

Here's a thorough, well-illustrated, up-to-date run-down on what stuff you need to know to fly an airplane in the U.S.: Principles of Flight, Weather; Navigation; Aircraft & Engine Operation; Flight Instruments; Aircraft Performance; Publications; Flight Computer; Radio Communications; Flight Planning. It's prepared by the Federal Aviation Agency, but it isn't heavy on you. Nice straight work.

**Private Pilot's Handbook of Aeronautical Knowledge**  
FAA  
1965; 174 pp. and sample map

**\$2.75** from:  
U.S. Govt. Printing Office Bookstore  
710 North Capitol Street  
Washington, D. C. 20402  
U.S. Govt. Printing Office Bookstore  
Rm 1463 14th floor  
Federal Office Building  
219 S. Dearborn St.  
Chicago, Illinois 60604

U.S. Govt. Printing Office Bookstore  
Rm 135 Federal Building  
601 East 12th St  
Kansas City, Missouri 64106  
U.S. Govt. Printing Office Bookstore  
Federal Building  
450 Golden Gate Avenue  
Rm 1023 Box 36104  
San Francisco, California 94102

or **WHOLE EARTH CATALOG**



**Used Plane Buying Guide**

An objective rundown on what you can expect buying a used plane is what you can expect from this sensible book. Besides information on purchasing and maintenance it gives comparative data (including price range) on the common light planes in the used market.

**Used Plane Buying Guide**  
James M. Triggs  
1962; 128 pp.  
**\$2.45** postpaid

from:  
Crown Publishers  
419 Park Avenue South  
New York, N. Y. 10016

or **WHOLE EARTH CATALOG**

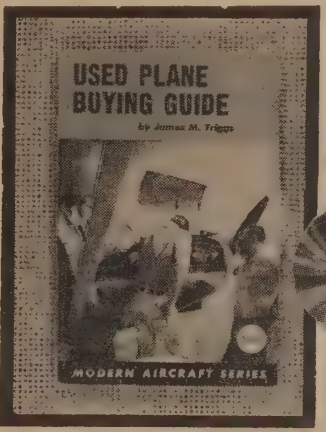

For current buying information your best source is **Trade-a-Plane**, which carries equipment, materials, parts, etc., as well as airplanes.

**\$4.00/yr.** (3 times monthly)

from:  
Trade-a-Plane Service  
Crossville, Tennessee



**Aeronautical Charts**

Mack Taylor is a friend who has a fondness for the blank places on other people's continents. He walks into them in his tennis shoes and makes friends with the chief and walks out and tells stories about how the main hazard in the jungle is dead-eye monkeys who shit on you from the trees. Mack says that often the only maps with information in the blanks are the ONCs—Operational Navigation Charts, available for 50¢ apiece. The Coast and Geodetic Survey Catalog of Aeronautical Charts has a map index for ONCs and sundry other flight maps and publications. The Catalog seems to be

free from:  
Distribution Division C-44  
Coast and Geodetic Survey  
Rockville, Md. 20852

**The Air Almanac**

Here's a book of pure data. If you need to know where sun, moon, planets, stars are, or where you are, this book is prime source. It is published quarterly for the forthcoming 3 months.

**The Air Almanac**  
570 pp.  
**\$3.75**

from:  
Superintendent of Documents  
U. S. Government Printing Office  
Washington, D. C. 20402  
or  
Her Majesty's Stationery Office  
49 High Holborn  
London W.C. 1

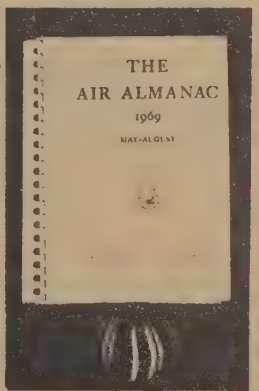

## Hot Springs

It seems incredible that there would be such a book. Here are map locations of all the known hot springs in the world, along with information on temperature, rate of flow, mineral content, and whether commercial or wild. You could travel the rest of your days from spring to spring, stopping at the Tatapani springs, on the west bank of the Sunkasi river ("3 springs forming small pool") 50 miles northwest of Mt. Everest, or the Hamman Ouled Sidi Abdeli ancient Roman baths, still flowing at 500 liters/minute, 81 F, 50 miles southwest of Oran, Algeria.

Published by the U. S. Geological Survey for a song, this directory fails to mention the plastic ice-water afterlife that awaits those who mess up wild hot springs.

### Thermal Springs of the United States and Other Countries of the World—A Summary

Gerald Waring  
1965; 383 pp.

from:  
Superintendent of Documents  
U. S. Government Printing Office  
Washington, D.C. 20402

\$2.75 postpaid

or WHOLE EARTH CATALOG

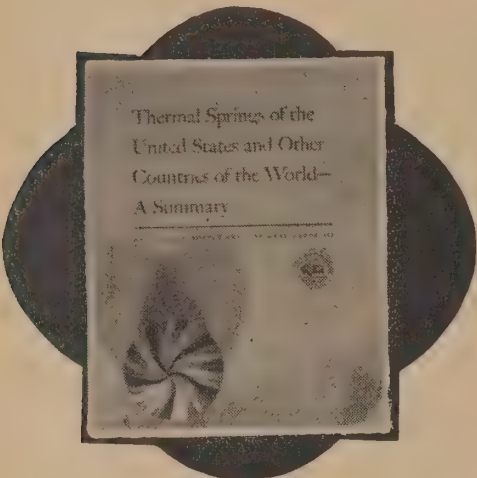
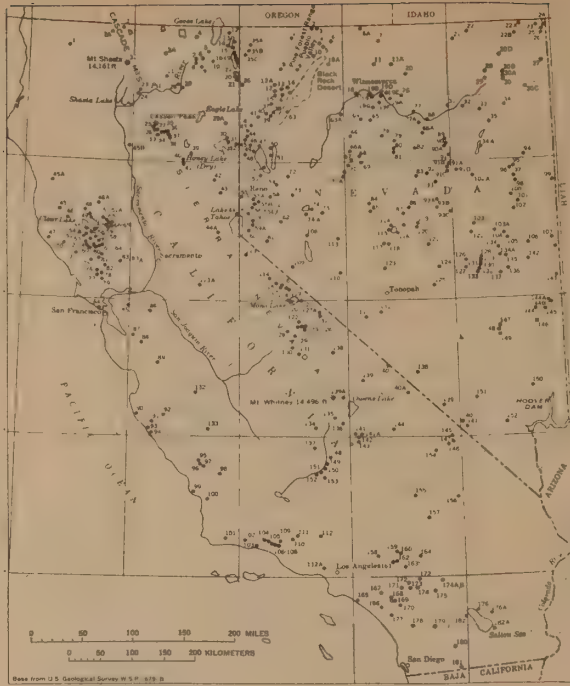

Thermal springs and wells in Argentina—Continued

No. on fig. 16	Name or location	Temperature of water (°C)	Flow (liters per minute)	Total dissolved solids (ppm)	Principal chemical constituents	Associated rocks	Remarks and additional references
55	El Saladillo de los Colorados	34	Moderately large	4,560	Na, SO <sub>4</sub> , Cl	Precambrian(?) strata	1 main spring and several small flowing wells.
56	Surgente de Copal de Guayapa, 15 km southwest of Patquia	22	Large	8,270	Na, SO <sub>4</sub> , Cl	do	Flowing well. Water used for drinking by cattle.
57	Totoritas, in La Rioja	26		400; 356	NaHCO <sub>3</sub>	Paleozoic strata	Water used for bathing.
58	Plismauta, 8 km west of Jachal	40; 45			Na, SO <sub>4</sub> ; free H <sub>2</sub> S	Paleozoic limestone	Water contains much Fe <sub>2</sub> O <sub>3</sub> and Al <sub>2</sub> O <sub>3</sub> . Ref. 912.
59	Quebrada de Huaco (Hedionda)	21-25	100	2,300-2,868	Na, SO <sub>4</sub> ; much free H <sub>2</sub> S	Paleozoic limestone	Several springs. Deposits of sulfur. Water used for bathing. Ref. 905.
59	El Volcan	27.1		Moderately high	Na, SO <sub>4</sub> , Cl; free H <sub>2</sub> S	Tertiary(?) deposits	Water used locally.

## National Geographic

Everyone knows about National Geographic. This is just a reminder, or a tribute. Long live.

### National Geographic

\$7.50 annual membership (\$9 outside U. S.) 12 issues

from:  
The Secretary  
National Geographic Society  
Washington, D. C. 20036

National Geographic publishes excellent maps at reasonable prices. We use two huge maps in the CATALOG office for geographical portrait of subscribers. Write for free publication list to above address.



## U. S. G. S. Topographic Maps

If you're interested in buying land or visiting remote areas you'll be using any maps you can get your hands on. The United States Geological Survey publishes the most accurate and detailed maps generally available for the U. S. (and possessions). Although some are a little dated, they consistently pack a lot of information into a fairly understandable format. Besides contour intervals, these maps indicate type of earth surface, roads, train tracks and trails, buildings, mines and various land marks; plus a whole lot of other stuff.

Two series of maps are available—15 minute quadrants (approximately 1 inch equals 1 mile, with 80 feet contour intervals, covering an area 14 X 18 miles); and 7.5 minute quadrants (approx. 2" = 1 mi., 40' contour, covers 7 X 9 mi.). The 7.5 minute maps are more up-to-date but have not been prepared for the whole country.

[Reviewed by Drew Langsner]

U. S. G. S. also has Distribution Centers at:  
ALASKA: Anchorage, Fairbanks, Juneau and Palmer  
CALIFORNIA: Menlo Park and San Francisco  
COLORADO: Denver  
TEXAS: Dallas  
UTAH: Salt Lake City  
WASHINGTON: Spokane

Canadian Topo maps from:  
Map Distribution Office  
Dept. of Mining and Technical Surveys  
615 Booth Street  
Ottawa, Ontario, CANADA

Maps cost 50¢ each and U. S. G. S. provides an index map of any state free. from:

Distribution Section  
U. S. G. S.  
Washington, D. C. 20242

## The Explorers Trademart Log

Most periodicals that have anything to do with exploring are about it, for people who don't do it: useless. This magazine is for explorers, by explorers. The span of subject matter includes backpacking, diving, sailing, flying, spelunking, prospecting, archeology, photography, treasure hunting, mountaineering, and conservation. The magazine is new and growing. Somewhat jolly in tone, it is full of specific gossip on tools, access, and current explorations.

[Suggested by Mack Taylor]

### The Explorers Trademart Log

\$3.00 per year (monthly)

from:  
Explorers Trademart, Ltd.  
P.O. Box 1667  
Annapolis, Md. 21404



A new edition of the booklet "Chart No. 1" which contains symbols and abbreviations used on all nautical charts issued by the U.S. Government has been published. Prepared jointly by the Coast and Geodetic Survey, the Naval Oceanographic Office, the Coast Guard, and the Lake Survey, the edition shows changes occurring since the publication was last printed in 1963. New chart symbols of primary importance include those designated as marine limit areas, such as shipping safety fairways in the Gulf of Mexico, etc. Illustrations depicting aids to navigation have been revised to reflect new technological advances in their construction. Copies may be purchased from the Coast and Geodetic Survey (C44), Rockville, Md. 20852 for 50¢.

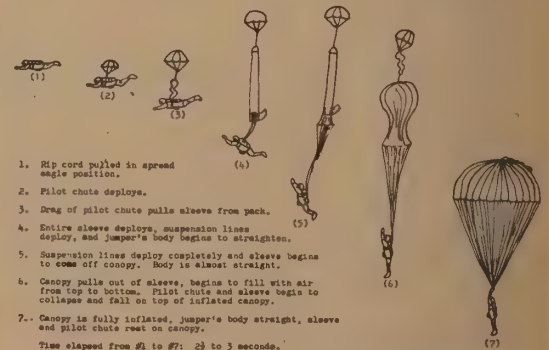

D. PARACHUTE DEPLOYMENT SEQUENCE

Excellent 3-dimensional versions of the smallest scale U.S.G.S. maps are available at \$4.00 postpaid from:

Army Map Service  
San Antonio Field Office  
Building 4011  
Ft. Sam Houston, Texas 78234



## Hitch-hiking in Europe

This primer will prepare you for some of the vagaries of the road in Europe or elsewhere. There is nothing much in it that you wouldn't learn soon enough for yourself—its main point being that there is no substitute for the experience of hitch-hiking. But the book is useful for its good sense, humor, and perspective—written in classic hitching style—a taste of the road which may help you through a down and out scene or two. In addition there are numerous tips on getting to Europe and back, where to go, meeting people, sleeping arrangements, other means of transportation, etc.—all as related to the hitch-hiker.

[Reviewed by Joe Bonner]

### APPENDIX

#### Recommended Guidebooks:

- Let's Go, The Student Guide to Europe Europe on \$5 a Day
- Michelin Guides in general (especially good because they're written for motorists)

#### Recommended Maps:

- Kummerly and Frey (Swiss mapmaker—available everywhere)

#### Other Material:

- Youth Hostel Directory (obtain from IYH)
- List of U. S. embassies
- List of American Express offices
- Phrase books, such as the Dover Publications Pocket dictionaries

Your special advantage is the experience of uncertainty, which you buy at a bargain rate. Uncertainty keeps you on the *qui vivre*, the best stance for seeing and learning. You don't know who you'll meet, what experiences you'll have, which places you'll see off the rut, what things you'll learn that aren't in the guidebooks (this one included). And despite the difficulties, getting started and keeping going is not that hard. Your troubles will usually offer you no alternative but to cope with them. And you do!

Rooms can be had cheaply anywhere in Europe any time of the year. Get them simple, without bath, but with breakfast. One hears so much crap about the need for reservations. I suppose it's true for American-type tourists, but working-men's rooms, student's quarters, plain but clean hotels, and private homes are always available to you as a non-gold-plated human being. The main railroad station of a large city usually has clean cheap rooms.

Whenever hitching is especially bad, try making it at gas stations, or anywhere else that personal contacts are possible—restaurants, truckstops, rest stations, picnic areas, campsites, etc.

**Who To Go With.** If you're going to go with anyone at all, the answer is unquestionably—go with a girl. If you're a guy, she'll be your passport to lots of rides. Take good care of her. If you're a girl, you've got the whole gamut of choice: a guy or another girl. From the standpoint of rides alone, you'll be better off with the girl.

Another essential is a good map. See the appendix for some recommended ones. In Europe, you'll have to know what's along the route you're taking to your destination. To merely know your destination is not enough. You'll have to make quick decisions at times about alternate routes suddenly presented by a stopped—and waiting—motorist. Maybe some Welshman will offer you a ride to Pwllheli, but doesn't know himself if it's on the way to Amlwch, your destination.



**Hitch-hiking in Europe: an informal guidebook**  
Ed Bury  
1969; 72 pp.

\$1.75 postpaid

from:  
Ed Bury  
P. O. Box 31123  
San Francisco, CA 94131

or WHOLE EARTH CATALOG

## New Horizons World Guide

Considering the areas covered by most travel or tourist guides, this one is by far the most inclusive. It covers every conceivable area (131 countries) and almost every small bit of information you may ever need. For example, where to get an English speaking doctor for \$15.00 at 3:30 in the morning.

[Reviewed by Mary McCabe]

### New Horizons World Guide

Pan American Airways  
1951 . . . 1969; 831 pp.

\$3.95 postpaid

from:  
Simon and Schuster, Inc.  
650 Fifth Avenue  
New York, N. Y. 10020

or WHOLE EARTH CATALOG

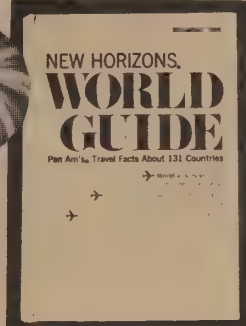
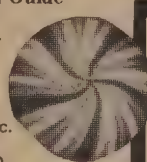

### MEDICAL CARE ABROAD

Intermedic (777 Third Avenue, New York, N. Y. 10017), is an organization formed to enable members while traveling to obtain immediate help from highly qualified, English-speaking physicians.

Members are assured that professional fees will not exceed \$8 for the first office visit, \$10 for the first house call at the hotel, or \$15 for an emergency nighttime hotel call. Intermedic provides a Directory of 340 participating physicians in 174 cities in 80 countries overseas with their day and night telephone numbers. The Directory also has pages which should be filled in at home with the member's medical history, allergies and the like.

Membership in Intermedic is sold directly from its headquarters, and through travel agents. Annual dues are \$5 for a Single Membership and \$9 for a Family Membership.

The Medical Passport Foundation, Inc., 35 East 69th Street, New York, New York 10021 (Telephone 212-879-9470) publishes a System of Medical Records which includes a wallet-size Medical Passport, an invaluable aid for travelers. It contains all facts concerning the individual's medical history—emergency information, laboratory findings, X-ray reports, allergies, sensitivities to drugs, diagnoses and treatments, lens prescription, electrocardiograms. Its plastic case holds other travel documents; costs \$2.75; for child, \$3. Used by U. S. State Department personnel. Complete information from the Foundation headquarters.

**CUSTOMS REGULATIONS AND DOCUMENTS REQUIRED FOR UNITED STATES CITIZENS . . .** Passport, smallpox vaccination certificate needed. No visa is required for 72-hour transit stop. A tourist visa is good for 60 days. A cholera vaccination is required of visitors from infected areas and is recommended for round-the-world and round-Asia tourists. 200 cigarettes, 50 cigars or ½ lb. tobacco, and 1 fifth of liquor are permitted duty free, 3 fifths if visitor is staying two weeks or longer. Tax exemption forms are available at shops (see SHOPS AND STORES).

**DRUGSTORES . . .** The American Pharmacy and Rexall Drug Co. in Tokyo stock American products. Japanese pharmacies have excellent, cheaper local toiletries and medicines.

**ELECTRIC CURRENT . . .** 100 volts, A.C., 50 cycles in Tokyo and Eastern Japan, 60 cycles in Osaka and Western Japan. No transformer plugs are necessary.

**FAUNA . . .** Boar, deer, pheasant, quail, snipe and wild goose in Central and Southern Japan, bear in Hokkaido.

**FLORA . . .** Cherry and plum trees blossom each spring. The national flower, the chrysanthemum, is widely displayed. Many other flowers and shrubs are grown and tended with great care. Tea plantations cover the low hills of Southern Honshu. Persimmons, loquat, figs and delicious tangerines called *mikan* are grown almost everywhere. Japanese strawberries and apples are huge and tasty.

## Reference Guide for Travelers

If you're going to some particular place in the world and want to know about the guide books etc. for that place, go to a library and find this excellent annotated bibliography of all travel books in print.

### Reference Guide for Travelers

J. A. Neal  
1969; 674 pp.

free at sensible libraries everywhere

## 340 Fielding, Temple and Nancy. FIELDING'S SUPER-ECONOMY GUIDE TO EUROPE. Dell, 1968. 880p. 4 x 7 paper. \$1.95.

There was a ready audience awaiting this guidebook when it first appeared in 1967—in fact, over 100,000 copies were sold in the first month after publication. One reason must be that American tourists support the publisher's claim that the annually revised FIELDING'S TRAVEL GUIDE TO EUROPE (see 339) is "the bible of travel." This new, budget-oriented offspring has the same jam-packed, pun-riddled prose and don't-spend-your-money-here-but-here approach of the older, standard work; but, without duplicating the information in that book, Fielding offers the economy guide for "the voyager who plans to s-t-r-e-t-c-h his or her outlay to the absolute maximum—and to spend less money in seeing more."

Chapters on 24 cities are provided in the book. Each city is covered by 12 subjects which include "Pennywise Fat Cats' Overnights" (high budget accommodations); "Medium Budget Overnights"; "Roof, Doornobs, and Bed" (the rock bottom recommendations); "Cap, Gown, and Quad" (for the student traveller); "Sights for Sore Eyes" (sightseeing); and "Budget Browsing and Buying."

### Accommodations

Car Rental  
Clothing  
Consulates  
Currency  
Customs Regulations

### Food & Drinks

Holidays & Festivals  
Night Life  
Passport  
Recreation  
Restaurants

### Shopping

Sightseeing  
Tipping  
Travel To  
air  
sea

### Travel Within

car  
organized tours  
rail  
streetcar  
Visas

## Travelers' Directory

Works like this: you have a 56-page directory of other outlaws you can stay with during your travels, and since you're in the book (or you don't get one) they have access to you. Send a 100-word description of yourself and your services and \$3 is how to get into it. Listings are 2/5 female, 3/5 male.

[Suggested by David Schoengold]

### Travelers' Directory

\$3.00 postpaid

from:  
Peter Kacalanos  
51-02 39th Avenue  
Woodside, New York 11377



## The International Atlas

Let your fingers do the travelling. This excellent new atlas from Rand McNally features fine map design, international perspective (not over-oriented to America or to the English language), and a series of maps of major cities of the planet all on the same scale.

[Suggested by John Holt]

### The International Atlas

1969; 558 pp.

\$34.95 postpaid (\$29.95 before Jan. 1, 1970)

from:  
Rand McNally  
P. O. Box 7600  
Chicago, Ill. 60680

or WHOLE EARTH CATALOG

# Learning

Dr. Spock

Baby and Child Care by Dr. Benjamin Spock is an excellent book to have handy, especially with a first child. The advice and explanations Dr. Spock gives regarding fever, rashes, coughs, inoculations and clothing for the infant is presented in simple language, somewhat wordy and repetitious, but in such a manner that you cannot misunderstand or confuse his instructions. Bathing an infant and sterilization of bottles, etc. seemed far too complicated. The chapters on illness, first aid, and special problems are excellent and probably the most read and re-read chapters in the book. Not only do you get lots of psychological guidance in the areas of toilet training, weaning, thumbsucking, and bed wetting but, as may be expected, there are sermons on aggressive children, no-war toys and growing up in a bomb-oriented world. You couldn't possibly agree with everything Dr. Spock says but after reading this book you are left with the feeling that you should relax, enjoy your baby, do what seems right and natural and that Spock is speaking from experience and common sense.

[Reviewed by Connie Duckworth]

It's a good idea to begin offering a sip of milk from the cup from the age of 5 months, so that the baby gets used to it before he is too opinionated.

More babies are overdressed than underdressed. This isn't good for them. If a person is always too warmly dressed, his body loses its ability to adjust to changes. He is more likely to become chilled. So in general, put on too little rather than too much and then watch the baby. Best guide is the color of his face. If he is getting cold, he loses the color from his cheeks.

To some degree, the first pregnancy spells the end of carefree youth—very important to Americans. The maidenly figure goes gradually into eclipse, and with it goes sprightly grace. Both eclipses are temporary but very real. The woman realizes that after the baby comes there will be distinct limitations of social life and other outside pleasures. No more hopping into the car on the spur of the moment, going anywhere the heart desires and coming home at any old hour. The same budget has to be spread thinner, and her husband's attention, all of which has gone to her at home, will soon be going to two.

155. Gradual weaning from breast to cup in the middle of the first year. If a mother is producing plenty of milk, how long should she plan to nurse? Best of all, most natural of all, is to nurse until the baby is ready for weaning to the cup. Most breast-fed babies are becoming bored between 5 and 6 months.

A 2-year-old baby shouldn't be worrying about the consequences of his actions. This is the period when he is meant to learn by doing and having things happen. I'm not advising that you never warn your child in words, but only that you shouldn't always be leading him out beyond his depth with ideas.

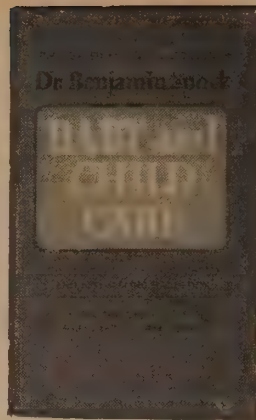

Baby and Child Care  
Dr. Benjamin Spock  
1946, 1968; 620 pp.

\$1.05 postpaid

from:  
Pocket Books  
1 West 39th Street  
New York, N. Y. 10018

or WHOLE EARTH CATALOG

## Creative Playthings

While living in Sydney for a few years, the C.P. catalog was our reliable source of valuable toys, meaning toys with lasting interest or play value and which are sturdy enough to last two—maybe three childhoods. Our orders were filled with no delay and packed well, so they always arrived on time and in good shape.

Some of the toys our mob likes best are a real stethoscope; an Eames-designed set of building cards; an African thumb piano; some rubber hand puppets, not the usual cast, but a whale, a crow, an alligator, and a frog; a rhythm band set—enough for the whole neighborhood, to name only a few of the indoor type. There are fair-weather toys for every child who likes to crawl, climb, hang, jump, slide, ride, rock or swing.

Baffled grandparents appreciate the C. P. catalog. So do kids who don't like to get clothes for Christmas.

[Reviewed by Gretchen Guard]

Husband's note: If you've got tools, you can make a lot of these toys, based on the pictures in the catalog—big simple stuff.

C. P. catalogs are free at Creative Playthings stores or write:  
Creative Playthings  
Princeton, N. J. 08540



## Kalimba

Unique instrument from Africa is for almost everyone, no matter what age or musical experience. Steel vibrators and wooden sound chamber produce delightful rippling music. 1 lb. RM001 \$12.95

A newcomer challenger to the Creative Playthings hegemony looks to be an outfit called Edu Vision. They too have nifty items for children and studied reasons for carrying them.

Catalog free

from:  
Edu Vision Co., Inc.  
682 Union Avenue  
Westbury, N. Y. 11590

## Community Playthings

Specializing in a wide variety of quality hardwood toys, the Society of Brothers (Bruderhof) demonstrates one area of effective community industry.

[Suggested by William Ilson]

## Community Playthings Catalog

free

from:  
Community Playthings  
Rifton, N. Y. 12471

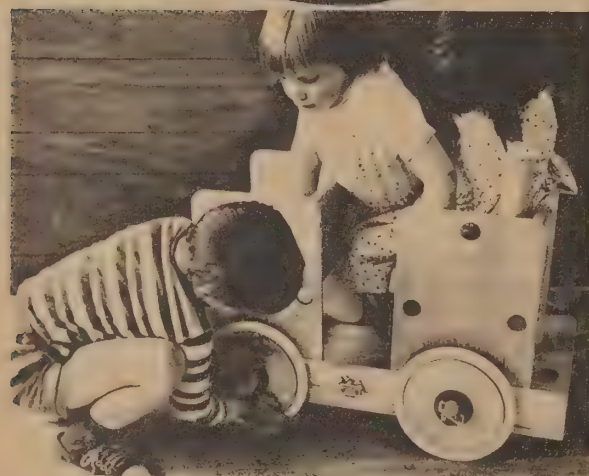

V55 Swedish Variplay Set, 9 pieces, 32 lbs. . . . . \$36.50

Year after year we would see the same thing happen. Here would be a boy in the third or fourth grade who seemed so hopelessly clumsy, unathletic, and ignorant of all the rules and skills of baseball that it looked as if he could never learn to play. Two years later that same boy would be a competent and often an expert player—and many of them did almost all their playing at school. They learned, as I say, by watching the older boys who did it best, and trying to do what they did.

As a matter of fact, they learned, on the whole, much better than the boys at another school, at which I taught, where there was far more play space, more time given to sports, and where teachers tried to teach softball. The boys in this school spent a good deal of their sports time standing around watching while someone 'explained' something to them.

My aim in writing it is not primarily to persuade educators and psychologists to swap new doctrines for old, but to persuade them to look at children, patiently, repeatedly, respectfully, and to hold off making theories and judgments about them until they have in their minds what most of them do not now have—a reasonably accurate model of what children are like.

## Inquarium™

A true departure from conventional crib toys. Live fish swim before the infant's eyes, introducing him to the visual pleasures of color and random motion. Heavy vinyl leak-proof pouch attaches securely to crib and contains iridescent nuggets. Fish not included. 14 oz. RE201 \$3.50

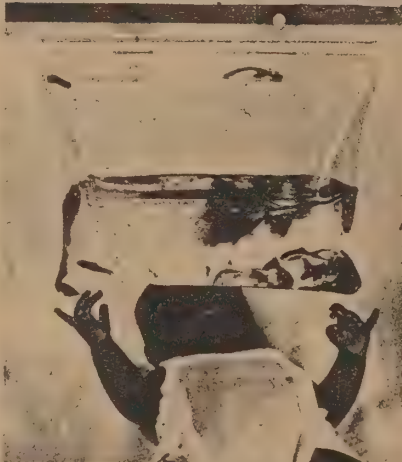

## Bigmouth™ Puppets

Simple rubber puppets for fantasy fun. Easy to use. Designed by Dion Porzlo.  
Alligator RG471 Bullfrog RG473  
Crow RG472 Whale RG474  
Ea. 14 oz. Each \$3.00



## How Children Learn

This rambling series of innocent everyday happenings to a bevy of pre schoolers is described, digested, and given educational depth by an extremely observant and articulate educator, Mr. Holt. The great strength of his book is its readability. His use of preschooler learning situations is ingenious, since it is a common reference point to all teachers and parents. Anyone who doesn't see toddlers in a different light after reading this book probably ought to write a book himself.

[Reviewed by Carol Guyton Goodell]

## How Children Learn

John Holt  
1967; 192 pp.

\$2.25 postpaid

from:  
Pitman Publishing Corp.  
20 East 46th Street  
New York, N. Y. 10017

or WHOLE EARTH CATALOG

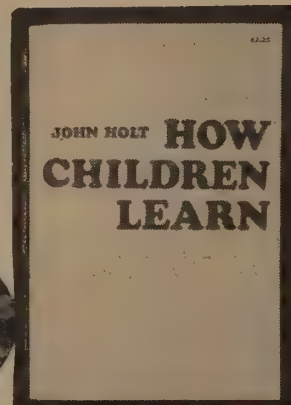

One of my earliest recollections—actually by now I remember the telling of it rather than the event itself—was of playing in the park with a friend my own age—about three, perhaps four—who out of a clear blue sky hit me in the head with his toy shovel. We had been playing peacefully; I never understood, then or later, why he hit me. Perhaps it was this same overpowering urge to see what would happen.

Bill Hull once said to me, "If we taught children to speak, they'd never learn." I thought at first he was joking.

When, through such play and fantasy, the children had taken these materials into their minds, mentally swallowed and digested them, so to speak, they were then ready and willing to play very complicated games, that in the more organized and businesslike situation had left other children completely baffled. This proved to be so consistently true that the experimenters made it a rule always to let children have a period of completely free play with the materials, before asking them to do directed work with them.

**The Lives of Children**

For some months, when speaking to teachers or to anyone else concerned with education, I have said that while there were many recently published books on education (my own among them) that I thought they should read, if they felt they had time for only one it should be **The Lives of Children**. It is by far the most perceptive, moving, and important book on education that I have ever read, or indeed ever expect to. For while I hope that in years to come we may learn much about human growth and development that we do not now know, I doubt that any one book will advance our understanding as much as this one.

It describes the lives of twenty-three children in the small private school in New York in which Dennison taught, and which has since been disbanded. They were black, white, and Puerto Rican in equal proportions. All were poor, half were on welfare, and about half "had come to us from the public schools with severe learning and behavior problems." . . . This school, spending no more money per pupil than the city's public schools, did not fail. The children got well, grew, learned.

[Suggested and reviewed by John Holt. This review is excerpted, at John Holt's request, from his review in Oct 9 N. Y. Review of Books.]

**The Lives of Children**  
George Dennison  
1969; 308 pp.

**\$6.95** postpaid  
from:  
Random House, Inc.  
201 East 50th Street  
New York, N. Y. 10022

or **WHOLE EARTH CATALOG**

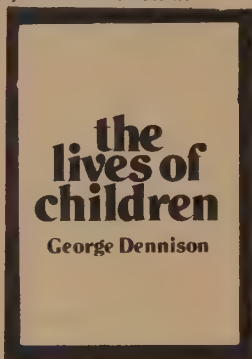

**Dibs in Search of Self**

Could this five year old child who "crawled around the edge of the room, lurking under tables, rocking back and forth, chewing on the side of his hand, sucking his thumb, lying prone and rigid on the floor when any of the teachers or children tried to involve him in some activity" actually be precocious? Could his teachers be right in their hunch that his behavior was too inconsistent to be the result of mental retardation? How could the tense secretive attitudes of his wealthy professional parents help explain Dibs' cultivation of such protective walls against the world? Could anyone help?

Dr. Axline's edited transcripts of the play therapy she used with Dibs is a moving fascinating chronicle. And Dibs—what a gutsy, amazing child!

[Suggested and reviewed by Carol Guyton Goodell]

**Dibs in Search of Self**  
Virginia M. Axline  
1964; 220 pp.

**\$1.75** postpaid

from:  
Ballantine Books  
101 Fifth Avenue  
New York, N. Y. 10003

or **WHOLE EARTH CATALOG**

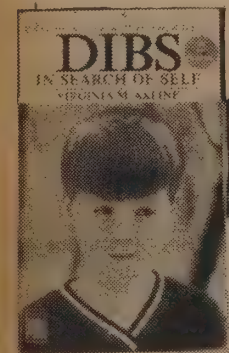

"Oh," I said. "Well, the furnace is out of order today. The men are down there fixing it."

"What is wrong with it?" Dibs asked.

"I don't know," I replied.

"You could find out, you know," he said, after a short interval.

"I could? How?"

"You could go down in the basement and hang around out of the way on the edge of things close enough to watch them and hear what they have to say," he told me.

"I expect I could," I replied.

"Then why didn't you?" he asked.

"To tell you the truth, Dibs," I replied, "It had not occurred to me to do that."

"You can learn lots of interesting things that way," he said.

"I'm sure of that," I told him. And I was just as sure that Dibs had learned many, many things in that manner, hanging around out of the way, on the edge of things, close enough to watch people and hear what they had to say.

In my opinion, the therapeutic value of this kind of psychotherapy is based upon the child's experiencing himself as a capable, responsible person in a relationship that tries to communicate to him two basic truths: that no one ever really knows as much about any human being's inner world as does the individual himself; and that responsible freedom grows and develops from inside the person. The child must first learn self-respect and a sense of dignity that grows out of his increasing self-understanding before he can learn to respect the personalities and rights and differences of others.

. . . [the children's] self interest will lead them into positive relations with the natural authority of adults, and this is much to be desired, for natural authority is a far cry from authority that is merely arbitrary. Its attributes are obvious: adults are larger, are experienced, possess more words, have entered into prior agreements among themselves . . .

When all this takes on a positive instead of a merely negative character, the children see the adults as protectors and as sources of certitude, approval, novelty, skills. In the fact that adults have entered into prior agreements, children intuit a seriousness and a web of relations in the life that surrounds them. . . . These two things, taken together—the natural authority of adults and the needs of children—are the great reservoir of the organic structuring that comes into being when arbitrary rules of order are dispensed with.

Here we come to one of the really damaging myths of education, namely, that learning is the result of teaching, that the progress of the child bears a direct relation to methods of instruction and the internal relationships of curriculum . . . To cite these as the effective causes of learning is wrong. The causes are in the child. When we consider the powers of mind of a healthy eight-year-old—the avidity of the senses, the finesse and energy of observation, the effortless concentration, the voracious memory—we realize immediately that these powers possess true magnitude in the general scale of things. . . . Why is it, then, that so many children fail? Let me put it bluntly; it is because our system of public education is a horrendous, life-destroying mess.

There is no such thing as learning (as Dewey tells us) except in the continuum of experience. But this continuum cannot survive in the classroom unless there is reality of encounter between the adults and the children. The teachers must be themselves, not play roles. They must teach the child, and not teach "subjects." . . . The continuum of experience and reality of encounter are destroyed in the public schools (and most private ones) by the very methods which form the institution itself . . .

**Push Back the Desks**

Every effective teacher has had projects and ideas which really turned kids on, but most of them don't take the time to write about just what it is that makes their classes remembered by former students as "one of the best years ever." Albert Cullum did, and his enthusiasm and involvement with his class of elementary kids over a twenty-year span spill over to the reader in a veritable flood of ideas, theories, and teacher war stories. He is explicit enough about his projects to make them instantly available to any admirer, but the major strength of the book is its ability to awaken a hundred or so related ideas in the teachers who read it. It is teachers like Mr. Cullum who epitomize the best aspects and possibilities of the self-contained classroom for elementary school children.

[Suggested and reviewed by Carol Guyton Goodell]

**Push Back the Desks**  
Albert Cullum  
1967; 223 pp.

**\$2.50** postpaid

from:  
Four Winds Press  
50 West 44th Street  
New York, N. Y. 10036

or **WHOLE EARTH CATALOG**



I have found that children are interested in two things—doing and doing now. Children are looking for the unexpected, not the safe; children are looking for noise and laughter, not quiet; children are looking for the heroic, not the common.

Shakespeare may be for scholars to debate and discuss and philosophize over, but he is also for Corky, a fifth-grader who died beautifully as Julius Caesar. There are 'murderers' galore in the elementary schools ready to help Macbeth kill Banquo; many a fifth- and sixth-grade girl can really whip up a moment of insanity as Ophelia.

**Teacher**

Teacher is as unphony, warm, and appealing as the grubby, tear streaked face of a child; it is also an important technical notebook for educators. Miss Ashton-Warner's organic approach to reading and writing is a detailed enough account to be explored further by teachers anywhere. It is of especial value to teachers working with primary children. Students with a cultural or language barrier, and adult illiterates.

[Suggested and reviewed by Carol Guyton Goodell]

Organic reading is not new. The Egyptian hieroglyphics were one-word sentences. Helen Keller's first word, "water," was a one-word book. Tolstoy found his way to it in his peasant school, while, out in the field of UNESCO today, it is used automatically as the only reasonable way of introducing reading to primitive people: in a famine area the teachers wouldn't think of beginning with any words other than "crop," "soil," "hunger," "manure," and the like.

Backward readers have a private Key Vocabulary which once found launches them into reading.

The power content of a word can be determined better from a backward reader than from an average reader.

Jose's reading problem is Jose. Or to put it another way, there is no such thing as a reading problem. Jose hates books, schools, and teachers, and among a hundred other insufficiencies—all of a piece—he cannot read. Is this a reading problem?

A reading problem, in short, is not a fact of life, but a fact of school administration. It does not describe Jose, but describes the action performed by the school, i.e., the action of ignoring every thing about Jose except his response to printed letters.

My own demands were an important part of Jose's experience. They were not simply the demands of a teacher, nor of an adult, but belonged to my own way of caring about Jose. And he sensed this. There was something he prized in the fact that I made demands on him. This became all the more evident once he realized that I wasn't simply processing him, that is, grading, measuring, etc. And when he learned that he could refuse—could refuse altogether could terminate the lesson, could change its direction, could insist on something else . . . we became collaborators in the business of life. . . . It boils down to this . . . we adults are entitled to demand much of our children . . . The children are entitled to demand that they be treated as individuals, since that is what they are.

**Hooked on Books**

If you've wrestled with ways to teach a non-reader as a teacher, if you've wondered what you could do as a businessman to help an obviously weak reading program in your schools, or if you're the worried parent of a Book Avider, then you'll tear through Hooked on Books with a firelike fervor fed on rekindled hopes.

Fader's program involves the saturation of students' surroundings with newspapers, magazines and paperback books chosen because they are written on subjects relevant to the world outside a classroom. Diffusion of such materials among teachers of all subjects and the use of writing, writing and more writing as the primary ways in which to teach English is another important tenet of this program.

It is a detailed report on an exciting and practical way to teach reading, and it's laced with such well written anecdotes about the inmates of Maxey Boys Training School where this program was first tried that Big Bill, Superduck, Hogman, and Lester the Poet seem as real and as teachable as they were to the authors.

[Suggested and reviewed by Carol Guyton Goodell]

**Hooked on Books: Program and Proof**  
Daniel Fader and Elton McNeil  
1968; 236 pp.

**\$1.75** postpaid

from:  
Berkeley Medallion Books  
200 Madison Avenue  
New York, N. Y. 10016

or **WHOLE EARTH CATALOG**

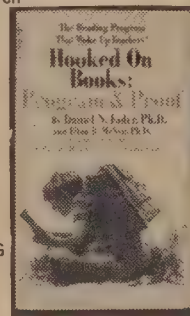

Those of us who participated in selecting the original 1,200 titles for the Maxey paperback library will never again have to be reminded how little we know about the students we teach. None of us will forget the untouched 700 titles that decorated our gleaming drugstore spinners while the boys read and reread the 500 they liked. . . . The 500 winners of our book Derby are included in the Reading List (pp. 148-173).

The boy turns, pulls out of his shirt Dick Gregory's *From the Back of the Bus*, waves it at the teacher, and shouts, "I bought it, man, I bought it! Bought four more while I was home. Didn't steal none!" Bought or stolen, those five books were the first that boy had ever owned.

Noise, noise, noise, yes. But if you don't like noise, don't be a teacher.

But there are two kinds of order, and which is the one we wish for? Is it the conscious order that ends up as respectability? Or is it the unconscious order that looks like chaos on the top? There is a separate world on each side of this question mark.

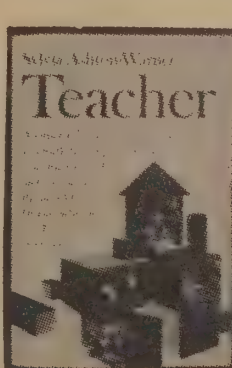

**Teacher**  
Sylvia Ashton-Warner  
1963; 224 pp.

**\$1.95** postpaid

from:  
Simon & Schuster, Inc.  
630 Fifth Avenue  
New York, N. Y. 10020

or **WHOLE EARTH CATALOG**

## Programmed Reading

If you have a pre-school or kindergarten age child who you feel is ready to learn to read but you don't know how to start, this series of programs may be your answer. The series of twenty-two books begins with a set of eight sound-symbol cards. Each 8 x 10" card has a picture and the sound (letter) it stands for.

When the child has learned all eight sounds without the help of the pictures, he is ready to begin the primer, which uses only the eight familiar sounds plus 'I', 'yes', and 'no'. Learning the sounds and getting into the primer may take a long time and plenty of help from you, depending on the age of the child and how much he can absorb in one sitting. Our children started short sessions before age four and it was several months before they reached the self-teaching level, about half-way through the primer. After that they were on their own, going through each book at their own rate and becoming fairly good readers by the time they started kindergarten.

The material in every book is presented in a highly entertaining way; drawings by Carol Andrews are funny and colorful so that learning to read never becomes a drag.

The main characters throughout the series are Sam, Ann, their little brother Walter, Nip the dog and Tab the cat. The beginning books are about their daily adventures and how they get into and out of trouble. In the more advanced books, when the mob is looking for adventure they visit the Roundabouts who live in a land where anything can happen. The last three books, also in the form of self-teaching programs, are stories from Greek mythology meaningfully written for seven and eight year olds.

Cynthia Buchanan has also written a three-part series, Programmed Geography (Macmillan) including The Earth in Space, Continents & Oceans, Latitudes and Climates. Our children were able to do this series successfully at eight years or so. Another excellent program by the Sullivan Associates is Programmed Astronomy (2 books).

[Suggested and reviewed by Gretchen Guard.]

## Programmed Reading

Cynthia D. Buchanan  
Sullivan Associates.

Programmed reading: The pre-reading series. 3 bks. bk. 1, Programmed pre-reader. 1966. \$1.80; 2nd ed. 1968. \$0.92; bk. 2, Programmed pre-reading. 1963. \$2.40; bk. 3, Programmed primer, \$1.32; readiness test, \$2.80; teacher's alphabet cards, \$3.60; student's alphabet cards, \$1.84; sound-symbol cards, \$1.92; teacher's guide to Pre-reader, stage 2, 1968, \$2.72; teacher's guide to Reading readiness, stage 1, 1968. \$2.00.

Programmed reading. 2 series. 1963. series 1. 2 vols. vol. 1, Programmed pre-reading, \$1.48; vol. 2, Programmed primer, \$1.24; reading readiness test, \$2.40 per pkg. of 10; series 2, Programmed reading, bk. 1, \$1.32; teacher's guide, \$0.72.

Programmed reading. 21 bks. 3 ser. 1963-66. Teachers guide to ser. 1, \$2.40; bks. 1-2, \$1.50 ea; teacher's guides to bk. 1, \$0.72; to bk. 2, o.p. bks. 3-7, \$1.68 ea; teacher's guides to bks. 3-7, o.p. pupils response bks. for bks. 3-7, \$0.32 ea; test bklet, \$0.96; teacher's guide, \$0.96; placement test, set, \$8.00; guide to reading tests, \$0.32. 7 filmstrips set, \$30.00; teacher's guide to filmstrips, \$0.96; Series 2, bks. 1-2, \$1.56 ea; bks. 3-7, \$1.68 ea; bks. 8-14 ea; teacher's guide to ser. 2, \$2.40; pupil's response bks. \$0.32 ea; Webster master's bks. 8-14, \$16.00; sound symbol cards, \$4.40; alphabet strips, \$1.48; test bklet, \$0.96; teacher's guide, \$0.96; text films available; Series 3. bks. 8-21, \$1.80 ea; pupil's response bks. 15-21, \$0.32 ea; teacher's guide, \$3.60; tests, \$0.96; teacher's guide to tests, \$0.96; bk. 15. 2nd ed. 1968. \$1.80; programmed reading evaluation set, \$130.00.

Programmed reading classroom starter set. 1967. \$360.00.

from:  
McGraw-Hill Book Co.  
Princeton Road  
Hightstown, N. J. 08520

Manchester Road  
Manchester, MO 63062  
8171 Redwood Highway  
Novato, CA 94947

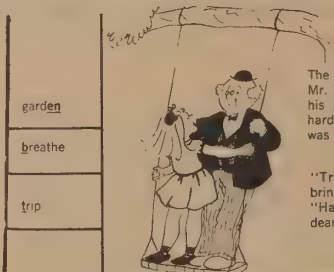

The next thing Ann knew, she and Mr. Roundabout were swinging in his garden. "Oh," she said, hardly daring to breathe, "that was the most wonderful trip!"

"Trip?" said Mr. Roundabout, bringing the swing to a gentle stop. "Have you been on a trip, my dear?"

## Initial Teaching Alphabet

As everyone knows, the English language is inconsistent. For instance, here are four different pronunciations of the letter A.

ape apple arm all.

i.t.a. eliminates all such inconsistencies by spelling with a separate symbol for each "a" sound:

æp appl arm aul

Eliminating contradictions in spelling and pronunciation makes learning to read and write a logical process. Anyone whose mind can grasp logic—and this includes three and four year olds—can learn to read with i.t.a. There are none of the complicated rules of the normal alphabet. Capitals in i.t.a. are just the regular size i.t.a. symbols written or printed a little larger. Each sound has its own symbol; there are 44 altogether.

After learning to read in i.t.a., the switch can be made to the conventional alphabet easily. The irregularities are not troublesome at this point, because the reader can read whole words at a time—not letter by letter—and can read for content.

i.t.a. is great for pre-school age children who want to read. At that age, kids get frustrated easily. The i.t.a. alphabet prevents the frustration by its consistency. We taught our 4 year old the sound of i.t.a. letter. Then we showed him how words could be made by blending sounds together. It took a while before he was able to blend the sounds by himself. But when that happened, he was then able to read.

i.t.a. is also good for teaching English to foreigners (many foreign languages also have one symbol or one group of symbols for each sound) and for remedial reading instruction. It is also a good tool for writing: once all the sounds of the symbols are learned, one can write anything he can say.

[Reviewed by Lora Ferguson]

thær wox næ wind tœ blœ him neerer  
tœ the tree sœ thær hee stæd. hee cœd see  
the huny, hee cœd smell the huny, but hee  
cœdn't kwiet reeçh the huny.

after a littl whiel hee cauld doun tœ yœ.

"Cristofer robin!" hee sed in a loud  
whisper.

"halloe!"

"ie thiŋk the bees suspect sumthiŋ!"

"whot sort ov thiŋ?"

"ie dœn't næ. but sumthiŋ tells mee  
that thær suspisihus!"

"perhaps thær  
thiŋk that yœ'r  
after thær huny?"

"it mæ bee that.  
yœ never can tell  
with bees."

thær wox anuher littl sielens, and then  
he cauld doun tœ yœ agæn.

"Cristofer robin!"

"yes?"



## Cuisenaire Rods

The first rod is a small wooden cube with a 1 centimeter side. The second is twice as long with the same cross section. The third is three times as long as the first. Each length has its own color. With these rods, a child can learn arithmetical operations and mathematical relationships even though he recognizes no mathematical symbols. (Children are capable of grasping mathematical concepts before they have the mechanical ability to write. Therein lies one of the great advantages of Cuisenaire rods.) For example, if a child puts the first (white) and the second (red) rods end to end he can see that together they are equal in length to the third (green) rod. Once he realizes that a white and a red always equal a green, he has learned something quite general about addition and equality. If, later, the numeral '1' is associated with the first rod, '2' with the second rod and '3' with the third, he will be in a position to grasp at once that  $1 + 2 = 3$ . But the rods have no absolute numerical value so that if the value '1' were assigned to the third rod rather than the first, the truth  $1/3 + 2/3 = 1$  would also be forthcoming as 'proved' by the general rule that the child discovered with the rods.

What is happening here is that algebra (the general case) is being learned before arithmetic (specific cases), as logically, it should be.

This is undoubtedly one of the best pieces of teaching equipment ever invented. But it is important that you don't show children the truths that the rods demonstrate. They must be allowed to discover these themselves or it won't work. Mathematics with Numbers in Color, books A, B, C, D, are a worthwhile purchase if you don't feel sure of how to use the rods. Also, For the Teaching of Elementary Mathematics will give an idea of what's going on when a child learns (as opposed to memorizing) math.

[Suggested by Virginia Baker  
Reviewed by Jane Burton]

Catalog free from:

Basic classroom kit for 25 kids (includes above books)  
\$57.50 postpaid

Cuisenaire Home Mathematics Kit \$12.50 postpaid  
from Cuisenaire Co. of America, Inc.  
9 Elm Avenue  
Mt. Vernon, N. Y.

112

Home Math Kit available from  
WHOLE EARTH CATALOG

The ITA Handbook for Writing and Spelling  
Mazurkiewics and Tanyzer  
1964; 50pp.  
\$2.00 postpaid  
from:  
Initial Teaching Alphabet Publications, Inc.  
20 East 46th Street  
New York, N. Y. 10017

From back cover of  
Winni the Po  
\$2.95 postpaid  
from:  
E. P. Dutton  
201 Park Avenue South  
New York, N. Y. 10003

Free literature about i.t.a. is also  
available from:  
Foundation for Educational  
Technology  
World Building  
Silver Springs, Maryland  
20910

discovering  
mathematical relationships  
with  
**RODS**

Fig. 1  
Fig. 2  
Tables of  
partition

Cardinal  
Ordinal  
Complements  
Factors  
Division without a remainder  
Fractions  
Non factors

Addition sum  
Subtraction difference  
Fig. 4

Product  
Cross to represent product  
Fig. 5

★ **I Know A Place**

Good simple idea, good simple book; pure mirror: you write and illustrate a book whose subject (not object) is you. Kids groove. Me too.

[Suggested by Joni Miller]

**I Know A Place (Vols. 1,2,3)**  
Robert Tannen  
1969; 134 pp.

**\$2.45** postpaid ( **\$2.05** to schools) per set

from:  
City Schools Curriculum Service, Inc.  
60 Commercial Wharf  
Boston, Mass. 02110 [Spanish edition is forthcoming.]

or **WHOLE EARTH CATALOG**

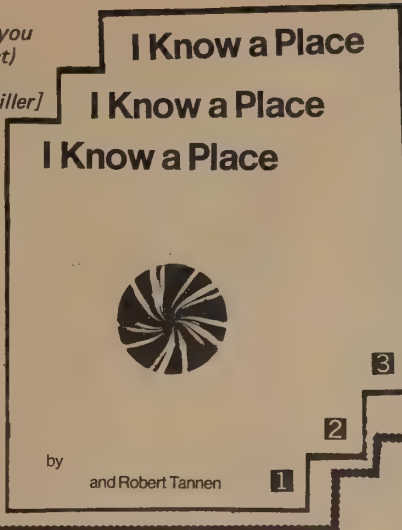

I know a person. A picture of this person is on the next page.

The name of this person is \_\_\_\_\_

The person was named \_\_\_\_\_

because \_\_\_\_\_

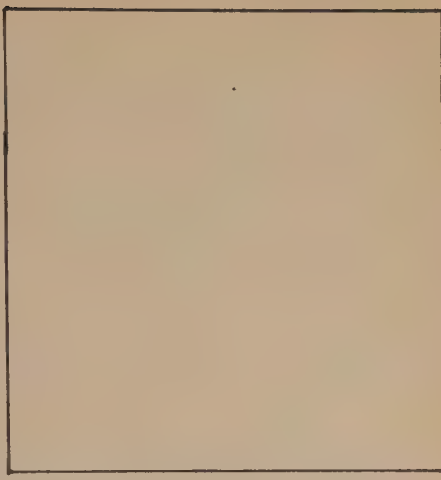

Nobody would suspect a plant like 5 to have anything to do with mathematics; it seems to be too unorganised and irregular. But a simple investigation of its structure and manner of growing, 6, reveals the Fibonacci series.

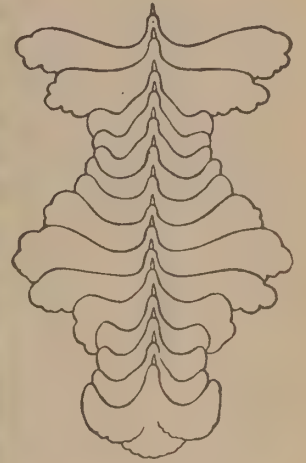
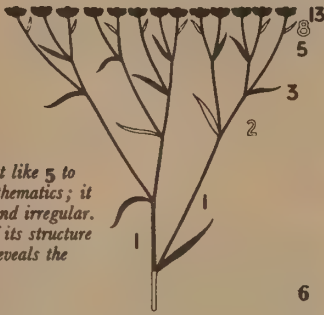

- ★ **Looking and Seeing**
1. Pattern and Shape
  2. The Development of Shape
  3. The Shapes We Need
  4. The Shape of Towns

This series of 4 books was designed for use in British schools. They are absolutely first-rate.

As befits such books, they are filled with excellent illustrations and the text is very explicit. While it would seem to have the 12-16 year olds in mind, the books are packed with stuff of interest to anyone who wants to know about the visual world and isn't too proud to read simple English.

The author's view is, "We have learnt to exert a certain amount of control over our world, over our surroundings and the lives we lead within them. But although we have gained much we have probably lost even more. We no longer possess the knowledge and the understanding to judge the things we make: our houses and factories, our implements and machines, our cities and roads. Because of this failure in judgement, we often find ourselves surrounded with such ugliness as would have horrified men of past ages. . . . It is now more important than ever that we should learn to understand the basic laws of the world around us, the man-made world and the world of nature." (bk. 1, p. 2)

The illustrations are widely drawn, but are consistently relevant to man. Traditional crafts, modern building, technology, graphics, ergonometics, D'Arcy-Thomson-like discussion of structure, social influences and industrial design are all dealt with.

One small foible—not all the illustrations are fully identified, except in the teachers' handbooks which are put out as small companions to the 4 books. These also deal with the short exercises which are set at the end of each section in the books.

[Suggested and reviewed by David and Lyn Roessler]

The same author and publisher have made another excellent series for younger children, **Learning to See** (price unknown). **Looking and Seeing** is shortly to be published in the U. S. by Van Nostrand-Reinhold, 450 E. 33rd Street, New York, N. Y. 10001. **Learning to See** is not. Once we get prices and publishers straightened out, **WHOLE EARTH CATALOG** will stock the books.



**Looking and Seeing** from:  
Books 1-4 Ginn & Company Ltd.  
Kurt Rowland 18 Bedford Row  
1966; 130 pp. each London, W.C. 1  
approx. **\$1.25** each



Both the pine cone, 3, and the dahlia, 4, have two sets of spirals. Count them and see if they are part of the Fibonacci series.



**Creative Drawing**

Ernst Röttger has a fruitful technique for graphic exploration (or any other kind).

He gives the students a medium—usually very simple—and some harsh constraints—usually very simple—and lets them find their own way out of fresh air. I suspect that this kind of medium exploration is better the more "useless" it is. Good book.

[Suggested by Dr. Morton Grosser]

**Creative Play Series**



**CREATIVE DRAWING**

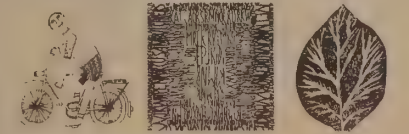

**Point and Line**

Röttger / Klante

Reinhold

**Creative Drawing** from:  
Ernst Röttger, Dieter Klante Van Nostrand-Reinhold Co.  
1963; 143 pp. 450 West 33rd Street  
**\$5.95** postpaid New York, N. Y. 10001

or **WHOLE EARTH CATALOG**

Van Nostrand-Reinhold also has Röttger books on **Paper Design, Wood Design, Clay Design.**

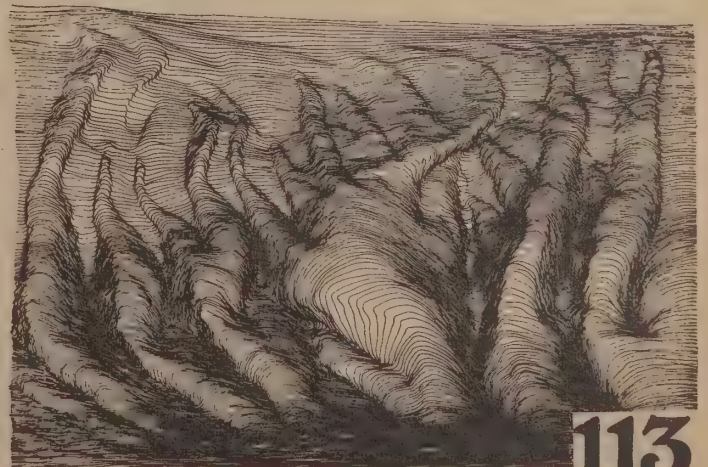

## Thinking Straighter

In an era when information is going to have to replace laws, it's increasingly important to be familiar with the anatomy of bullshit (manipulation by language). Everybody does it, and that's cool; it's just when you don't know it's happening that it gets hazardous. This book does vivid, organized analysis of ads, political statements, and other bubbles of our day. How to build your own shock-proof crap detector.

**Thinking Straighter**  
George Henry Moulds  
1965; 234 pp.

**\$4.75** postpaid from:  
William C. Brown Book Co.  
135 South Locust Street  
Dubuque, Iowa 52003  
or WHOLE EARTH CATALOG

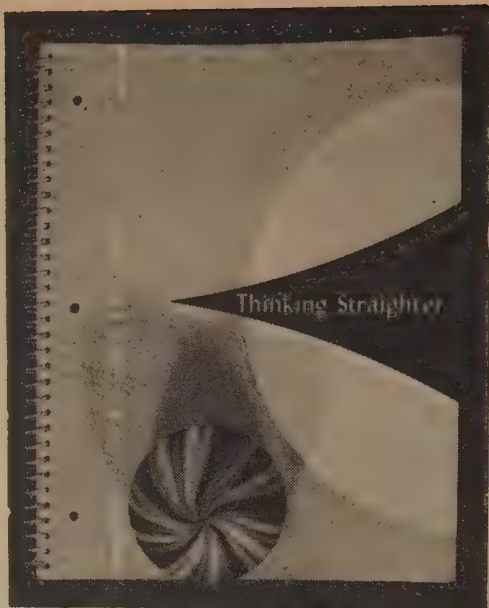

## DRAWING THE LINE

Meaning: Sharp distinctions are drawn where no sharp distinction exists.

Example: "Either you tell the truth or you lie."

The motive is the reason behind the argument; the intent is the reason ahead of the argument.

## QUOTATION OUT OF CONTEXT

Meaning: Quotation out of context is a fallacy when the effect of quoting a given statement without its context is to distort the original meaning in context.

Example: Someone quotes the Bible as saying that "money is the root of all evil" but leaves out the preceding words, "the love of."

## REPETITION

Meaning: We buy or believe because we have heard or seen the idea or the product name so often.

Example: Radio commercial: "Get up with GET-UP. GET-UP's got get up. Got it? Get it! Get GET-UP!!"

## ATTACKING A STRAW MAN

Meaning: Your opponent either (1) restates your position falsely or (2) exaggerates the consequences that may follow from your position.

Example: (1) Smith: "I am opposed to capital punishment."  
Jones: "I'm not."  
Smith: "You ought to be; capital punishment is unchristian."  
Jones: "I'm getting tired of people like you who oppose punishing criminals."  
(2) Smith: "I am opposed to capital punishment."  
Jones: "You fellows that are against capital punishment must want your daughters molested every time they leave the house."

## Jackdaws

A Jackdaw is a big envelope of facsimile goodies on some spectacular bit of history or science. You can shuffle through the artifacts in your own direction. You can see that history is invariably funky in the making. Thereby funky you can feel a little more connected.

[Suggested by Allan Lang]

List of Jackdaws free (individual Jackdaws cost \$2.95) from:  
The Viking Press  
625 Madison Avenue  
New York, N. Y. 10022



## Musical Instruments Made to be Played

Dryad Press in England has a series of craft books that may be particularly apt for school kids. Their Musical Instruments book has clear instructions and full-size plans for the fabrication of simple drums, shakers, xylophones, glockenspiels, dulcimers, psalteries, etc. Looks like fun. Other books of theirs we've seen include one on Netting (40¢) and one on Making and Playing Bamboo Pipes (\$2.70).

[Suggested by Richard Raymond]

### Tuning and Playing the Bowed Psaltery

The notes to which the strings should be tuned are given on the full size drawing on the inserted sheet. See also diagram 70 for the compass of the instrument. Tune the notes of the strings to the notes of a piano. In playing, rest the short side of the triangle against the body just above the left hip, and with the left hand, support the instrument towards the other end. Holding the bow in the right hand, bow the far end of each string. See plate 6. The diatonic scale of C is on the right. Reach over to the other side for the sharps and flats. It is necessary to lift the bow from string to string. True legato playing is impossible but it is easy to play sustained notes, and these are particularly acceptable when used with tuned percussion instruments.

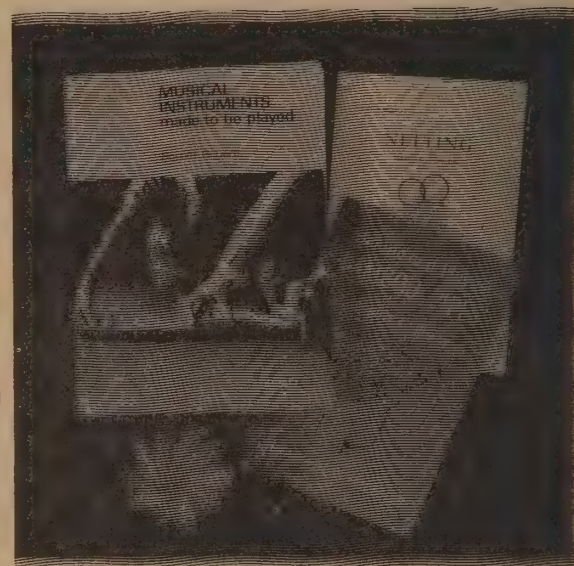

**Musical Instruments Made to be Played**  
Ronald Roberts  
1965; 81 pp. and plans

**\$6.50** postpaid from:  
Dryad Press  
Northgates, Leicester  
ENGLAND

Wood Ridge, N. J. 07075

or WHOLE EARTH CATALOG

## Encyclopedias A page from General Encyclopedias in Print 1968; S. Padraig Walsh; 112 pp.; \$3.00 postpaid from R. R. Bowker Company, 1180 Avenue of the Americas, New York, N. Y. 10036.

Listed below are 22 general encyclopedias in print (and one as yet unpublished and unrated title), which comply, in varying degrees, with the criteria for reference books established by professional librarians and educators. With some exceptions, these sets are currently approved by the Subscription Books Committee of the American Library Association, are listed as desirable purchases in the H. W. Wilson catalogs, and appear on the approved lists issued by several state and local education authorities. Each encyclopedia has been allocated a number rating according to (a) its frequency of inclusion in standard reference book selection guides and bibliographies, (b) where too new to be included in such guides, its compliance with accepted evaluative criteria, and (c) its cost in comparison with other similar and equally rated works. Where two or more sets have been equally rated, they are listed by order of cost within their ratings.

NUMBER RATING	TITLE	LOWEST PRICE	SUGGESTED AGE SUITABILITY	VOLUMES	PAGES	WORDS (MILLIONS)	ILLUSTRATIONS	COST PER MILLION WORDS	COST PER 1,000 ILLUSTRATIONS	COMB. TOTAL COSTS
MULTI-VOLUME GENERAL ENCYCLOPEDIAS										
15	WORLD BOOK ENCYCLOPEDIA (p. 19)	\$179.80	9-Pop. Adult	20	12,100	8.5	25,000	\$21.14	\$ 7.19	\$28.33
15	ENCYCLOPEDIA INTERNATIONAL (p. 22)	199.50	10-Gen. Adult	20	11,908	9.5	19,000	21.00	10.84	31.84
15	NEW BOOK OF KNOWLEDGE (p. 24)	199.50	7-14	20	9,442	6.3	22,400	31.66	8.90	40.56
15	MERIT STUDENTS ENCYCLOPEDIA (p. 27)	289.50	9-17	20	12,144	9	15,000	32.16	19.30	51.46
15	COLLIER'S ENCYCLOPEDIA (p. 29)	329.50	12-Adv. Adult	24	18,920	21	17,000	15.67	19.38	35.05
15	ENCYCLOPEDIA AMERICANA (p. 32)	375.00	12-Adv. Adult	30	27,750	31	18,100	12.10	20.83	32.93
15	ENCYCLOPAEDIA BRITANNICA (p. 35)	459.00	15-Adv. Adult	24	28,264	36.5	22,702	13.56	20.21	33.77
12	GROLIER UNIVERSAL ENCYCLOPEDIA (p. 38)	99.50	10-Gen. Adult	20	6,342	5	12,000	19.90	8.27	28.17
12	COMPTON'S ENCYCLOPEDIA (p. 40)	136.85	9-17	24	10,116	8	22,544	17.10	6.07	23.17
12	NEW CATHOLIC ENCYCLOPEDIA (p. 43)	550.00	15-Adv. Adult	15	16,522	15	7,500	36.66	73.33	109.99
10	BRITANNICA JUNIOR ENCYCLOPAEDIA (p. 45)	149.90	8-14	15	7,878	5.3	11,227	29.00	13.35	42.35
10	CHAMBERS'S ENCYCLOPAEDIA (p. 48)	259.00	15-Adv. Adult	15	14,500	14.5	4,000	17.86	64.75	82.61
10	AMERICAN PEOPLES ENCYCLOPEDIA (p. 51)	259.50	10-Gen. Adult	20	11,068	10	15,654	25.95	16.57	42.52
8	NEW STANDARD ENCYCLOPEDIA (p. 53)	119.50	10-Gen. Adult	14	9,038	6	12,000	19.91	9.95	29.86
8	OUR WONDERFUL WORLD (p. 55)	189.50	9-17	18	8,500	5.5	15,745	34.45	12.04	46.49
6	AMERICAN EDUCATOR ENCYCLOPEDIA (p. 61)	129.50	9-17	14	7,400	5	11,774	25.90	10.99	36.89
6	CATHOLIC ENCYCLOPEDIA FOR SCHOOL AND HOME (p. 64)	184.50	10-Gen. Adult	12	8,473	5	6,500	36.90	28.38	65.28
4	NEW CAXTON ENCYCLOPEDIA (p. 66)	259.00	12-Gen. Adult	20	6,720	6	20,000	43.16	12.95	56.11
2	FUNK & WAGNALLS STANDARD REFERENCE ENCYCLOPEDIA (p. 69)	37.25	15-Gen. Adult	25	9,660	7	5,000	5.32	7.45	12.77
2	ILLUSTRATED WORLD ENCYCLOPEDIA (p. 71)	39.95	8-14	21	7,000	4.5	15,000	8.87	2.66	11.53

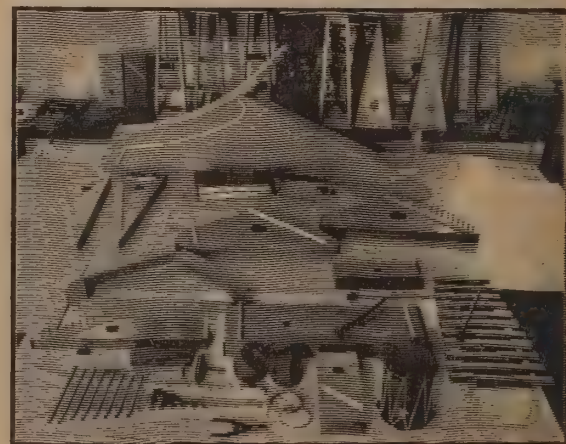

A pattern of instruments. In addition to showing many of the instruments described in the book, this photograph shows the frame and soundboard assembly of a Spinet and a Fidel with its bow. Nearby lies the template for a viola back.



**Media & Methods**

*A slick good education magazine. I can see that running a soft magazine in the hard-sell education media market is difficult, but Frank McLaughlin is doing all right.*

Media and Methods  
Frank McLaughlin, ed.  
\$5.00/yr. (nine issues)  
\$6.00 in Canada

from:  
Media & Methods  
134 North 13th Street  
Philadelphia, PA 19107

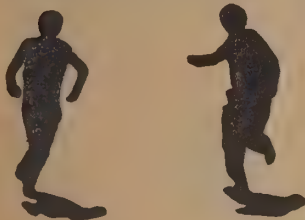

There can be no black-white unity until there is first some black unity. (Malcolm X Speaks, p. 21)

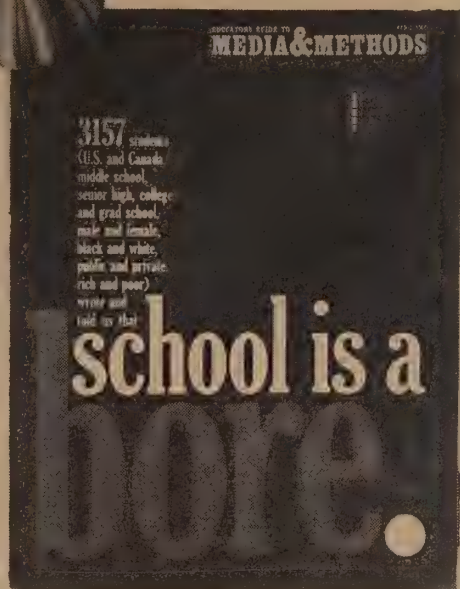

The mood of the whole conference was implicit in Culkin's style and attitude: Cut the crap . . . create a relaxed atmosphere . . . communicate with each other . . . share experiences . . . have some fun, and the learning will take care of itself.

school SCHOOL school SCHOOL school SCHOOL school SCHOOL  
FAKE fake FAKE fake FAKE fake HI hi HI hi HI hi HI hi HI  
CRACKED cracked CRACKED cracked SMILE smile SMILE smile  
cold COLD cold COLD cold BARE bare BARE bare BARE bare  
HALLWAYS corridors HALLWAYS corridors HALLWAYS corridors  
assignments ASSIGNMENTS assignments ASSIGNMENTS assignments  
SILENCE silence SILENCE silence SILENCE silence SILENCE  
BEHAVE behave BEHAVE behave BEHAVE behave BEHAVE behave  
discipline DISCIPLINE discipline DISCIPLINE discipline DISCIPLINE  
rules RULES rules RULES rules RULES rules RULES rules  
boredom BOREDOM boredom BOREDOM boredom BOREDOM  
GOSSIP gossip GOSSIP gossip GOSSIP gossip GOSSIP gossip  
BLUES MONDAY BLUES MONDAY BLUES MONDAY BLUES MONDAY  
test COLLEGE TEST grades college test college grades  
grades marks marks rank rank grades marks tests marks  
monotonous monotonous MONOTONOUS monotonous MONOTONOUS  
correct correct correct wrong wrong like hate hate  
hate hate hate hate hate hate hate hate hate hate hate  
pretend pretend pretend pretend try try try try try  
dumb dumb stupid stupid stupid dumb stupid stupid  
EMBARRASS EMBARRASSEMBARRASSEMBARRASS EMBARRASS

—Valerie Thibaudeau (St. Mary's Academy, Milwaukee, Wisconsin)

If "educators" are to be "liberators," they must become strategists of change. Students want to learn the skills and tools of change. Under the present system, violence seems to be the only tool available to them. If other methods are studied, there may be less "head-cracking" on campuses and city streets, and fewer incidents of warfare among nations.

The feeling of contempt so many college professors feel toward high school teachers and high school teachers in turn feel toward elementary teachers is shot through with irony. What has been consistently borne out in my experience is that the best teaching takes place at the elementary level (especially nursery school through 3rd grade). The best environments for learning are reflected in these "elementary" situations, the most natural employment of media are demonstrated, and the most humane relationship between adult and child exist.

**Educator's Guide to Free Films**

*This is an invaluable reference if you are interested in film education. The book has indices of contents, film listings, cross-index; titles, subject, and source and availability. The source and availability index saves hours of time, although it does not indicate whether or not you need a special order form. It also indicates whether you pay mailing cost one-way or two-way. Every school or proto-school should have a copy.*

[Suggested and Reviewed by Chip Chappell]



**Educator's Guide to Free Films**  
1968; 784 pp; 49443 films

\$10.75 postpaid

from:  
Educators  
Progress  
Service  
Randolph  
Wisconsin  
53956

**CIRCLE OF THE SUN**

16mm Sound 29 min.  
This film, in full color, records one of the last gatherings of the Blackfoot Confederacy. It shows the sun dance, but it also reflects the predicament of the younger generation—those who have relinquished their ties with their own people but have not yet found a firm place in the changing world. (Available from the Boston, Chicago, Detroit, Los Angeles, New Orleans, and Washington offices. See Source Index for addresses and areas served by each.) (Not cleared for TV)  
Consulate General of Canada

**CONQUEST OF LIGHT**

(1964) 16mm Sound 10 min.  
This film tells the story of the laser (sometimes called an optical maser), a device with almost unlimited potential in many areas. Although the film explains basically how a laser works and what it is, it does so in language clearly understandable to a non-technical audience. (Not cleared for TV)  
Bell System Telephone Offices

**WFF 'N PROOF**

*The WFF 'N PROOF games came out of the ALL project (Accelerated Learning of Logic) at Yale Law School. This project was established in 1960 to develop materials to teach mathematical logic to elementary school students. The authors' first principle in designing the games was that they be fun to play.*

*WFF 'N PROOF is a series of 21 games. The first ones can be played by children (starting around age eight), the last ones are difficult enough to interest logicians. The first game can be bought separately under the name of just 'WFF.' It is the best game and children always like to play it. In it you learn what a WFF (well formed formula) is, and there is no nicer way of doing that. The rest of the games teach you about constructing logical proofs. They are more tedious and a good teacher can find ways of doing this which are more fun. There's no harm in getting the whole set, however, and using it as long as it works.*

[Reviewed by Jane Burton]



WFF \$1.50 postpaid  
WFF 'N PROOF \$8.00 postpaid  
Tee Tickle \$1.00 postpaid  
The REAL Numbers Game \$2.00 postpaid  
On-Sets: The Game of Set Theory \$5.00 postpaid  
The Propaganda Game \$6.00 postpaid

from:  
WFF 'N PROOF  
P. O. Box 71  
New Haven, Conn. 06501

or WHOLE EARTH CATALOG



**Krazy Leg**

*Watching the magnetic pendulum swing this way and that over the target of other magnets I kept thinking of Hero's steam engine—just a toy. This toy, like Hero's, lets you play with an invisible dynamic and get used to invisibility and dynamics and how just a little shift here makes a big change there.*

[Suggested by Jeff Wilson]

Krazy Leg  
\$10.00 postpaid

from  
Rathon, Inc.  
2931 Irving Blvd., Suite 103  
Dallas, Texas 75247  
or  
WHOLE EARTH CATALOG

Soothe your nerves and while away the time watching this seemingly intelligent swinger trying to find a stable field.



**Playground Equipment**

*A list of playground equipment sources is available free from:*

Council for Parks and Playgrounds,  
15 Gramercy Park  
New York, N. Y. 10003

**Index to 16 mm Educational Films**

*For those who want to know what the whole situation is this index compiled by the National Information Center for Educational Media (NICEM) contains ca. 26,000 titles. These are recent films from the lists of the Library of Congress and film distributors.*

[Suggested and reviewed by Chip Chappell]

**Index to 16 mm Educational Films**  
2nd edition, May 1969

ca. \$50.00 postpaid

from:  
McGraw-Hill, or at Libraries, film distributors

from:  
Rathon, Inc.  
2931 Irving Blvd., Suite 103  
Dallas, Texas 75247

or WHOLE EARTH CATALOG

**THIS Magazine is about Schools**

*This is a double-good magazine about schools. Made in Toronto, it's global in context and it's superbly written and edited. Everything else we've seen on education looks stale and sad next to it.*

[Suggested by Jane Burton]

**THIS Magazine is about Schools**

**\$3.50** for one year (quarterly)

from:  
THIS Magazine is about Schools  
P. O. Box 876, Terminal A  
Toronto 1, Ontario, CANADA

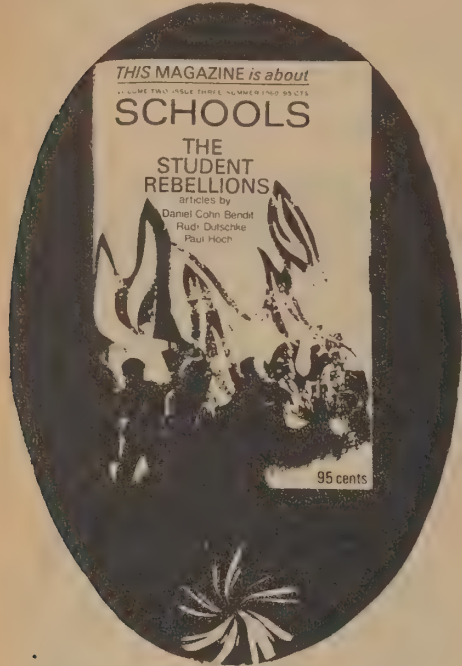

One of the students looked at President Harris Wofford and asked: "If we join your Socratic seminar, will you come and drop acid with us?"

Mr. Spelina's voice rises to a crescendo; he has not finished, but he has outdone himself, and he is outdoing the class. Delight has turned to confusion, and panic is spreading in the ranks. The French are holding fast, but the Spanish, with the exception of Mr. Ameller, are going under; Miss Fanaras has gone under. Mr. Cayo Junior is thinking about his girl-friend, and Mr. Rodriguez has decided to abandon English.

A geography teacher from Whitby spoke of how he started off teaching knowing so little about geography that he used to call it geometry.

Then to the accompaniment of loud boos and hisses, with only a scattering of applause, the vice-president of the Ontario Union of Students tore up his Bachelor of Arts diploma and marched out of the building.

Until the cops attacked, the construction of the barricades was a bit like a celebration. There was an extraordinary atmosphere. If the police had retreated, there would have been a marvelous explosion of joy, everybody would have celebrated the liberation of the Quarter. We'd even thought about bringing along some orchestras. But the darker it got, the more the barricades got reinforced and multiplied, the more we realized that the attack of the cops, if it took place would provoke a massacre. That's why I agreed to go to the Rector's (Roche of the Sorbonne), not to discuss anything but to explain to him what was going to happen if the cops didn't withdraw.

**New Schools Exchange**

*A much needed service, the New Schools Exchange functions as an access switchboard for individuals and organizations trying alternatives to the big gray schoolhouse. The Exchange publishes a directory of all the new schools and educational reform groups, and they put out a weekly newsletter describing new school attempts (8-10 a week).*

[Suggested by Jim Fadiman]

New Schools Exchange  
Harvey Haber, Cass Sperling, eds.

**\$1.00** /month (or if need be, free)

from:  
New Schools Exchange  
2940 Hidden Valley Lane  
Santa Barbara CA 93119



**116**

The lesson to us is: do not learn crafts from famous artists, but rather from competent technicians. Avoid like the plague teachers who talk a lot about self-fulfillment, self-realization, togetherness in creativity, or centering of your soul (that's for potters).

**THE HARD LIFE**

prepares children for the illogicalities and hardships of our present-day regimented existence. **WAR BUSINESS TABOOS.**

points out the drawbacks of organized efficiency. **FORCED TO READ SET BOOKS.**

shows how boredom can arise from enforced activity and lead to inactivity. **DOZING IN CLASS.**

satisfies a child's need for simplified, structured surroundings. **YOU KNOW WHERE YOU ARE.**

permits nervous teachers to avoid personal relations with children. **RETREAT TO THE STAFF ROOM.**

**THE SOFT LIFE**

prepares children for life as active individuals. **TRY IT MY WAY.**

points out the drawbacks of organized inefficiency. **CAN'T FIND MY BOOK.**

shows how boredom may arise from freedom, also, and lead to activity. **MUSTN'T WASTE OPPORTUNITIES.**

satisfies a child's need for diversity in exploratory play. **THIS IS JUST A MODEL.**

permits teachers to get to know children well, on equal terms. **NO TALKING DOWN.**

**THE HARD-SOFT LIFE**

enjoys the advantages of the hard and soft. **CONTRAST.**

shows how environment affects people and their work. **GRAPH PAPER AEROPLANES.**

allows children to learn how to get the best of both hard-and soft worlds. **COMPUTERGRAPHIC PAINTING.**

demonstrates the need to work in an intermediate zone. **DRAMA IN A FRAME.**

permits teachers to teach the way they like best. **CHALKDUST FOR ME.**

The hard-soft school might look something like this

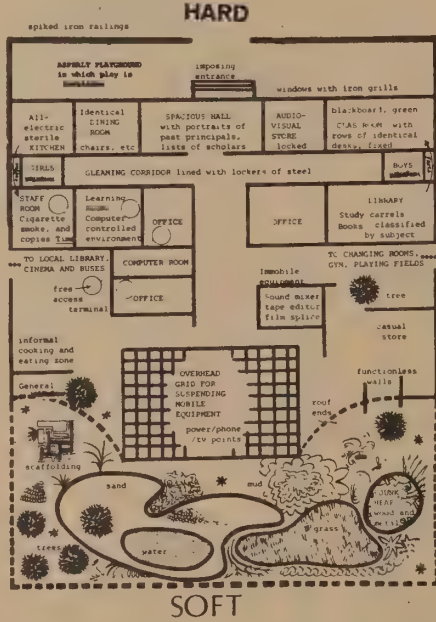

**Teaching As a Subversive Activity**

*You may have noticed that schools are society's goat just now, and the blame machine revs on and on. The authors of this handy de-crisis book take a nice clean no-blame revolutionary approach to things: what works this minute and doesn't work this minute. In their experience (high-school), instruction in authoritative subject matter doesn't work very well. What does work is an experience-based inquiry approach to learning to learn and learning to selectively un-learn: i.e. basic survival strategy in an environment of change. What's nice is they aren't just threatening: they have gathered and published a strong collection of technique.*

**Teaching as a Subversive Activity**  
Neil Postman and Charles Weingartner  
1969; 219 pp.

**\$5.95** postpaid

from:  
Delacorte Press  
750 Third Avenue  
New York, N. Y. 10017

or **WHOLE EARTH CATALOG**

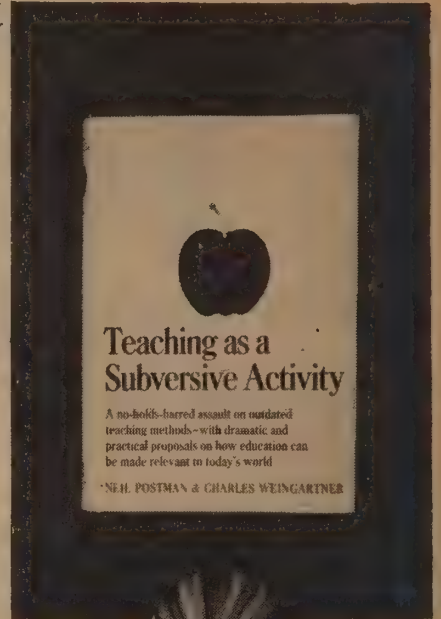

The new education, in sum, is new because it consists of having students use the concepts most appropriate to the world in which we all must live. All of these concepts constitute the dynamics of the questioning, meaning-making process that can be called "learning how to learn." This comprises a posture of stability from which to deal fruitfully with change. The purpose is to help all students develop built-in, shockproof crap detectors as basic equipment in their survival kits.

What we confront, at this juncture, is a most difficult problem in education: helping students to unlearn much of what they 'know.' Josh Billings said it almost a century ago: "The trouble ain't that people are ignorant; it's that they 'know' so much that ain't so." What are some of the things these students know that 'ain't so?' Well, for example, they 'know' that 1) the more 'content' a person 'knows,' the better teacher he is; 2) that 'content' is best 'imparted' via a 'course of study'; 3) that 'content' is best kept 'pure' by departmentalizing instruction; 4) that 'content' or 'subject matter' has a 'logical structure' or 'logical sequence' that dictates how the 'content' should be 'imparted'; 5) that bigger schools are better than smaller schools; 6) that smaller classes are better than bigger classes; 7) that 'homogeneous grouping' (with students 'grouped' on the basis of some real or fancied similarity) makes the learning of subjects more efficient; 8) that classes must be held for 'periods' of about an hour in length, five days a week, for about 15 weeks in order for a 'course' in a 'subject' to happen.

It comes as a shock to the students that there is no evidence to support any of these contentions. On the contrary, there is massive evidence to confute them. It takes some doing, however, to help students to recognize the fact that most of their deeply internalized assumptions about 'education' are based on misinformation rather than information.

The instructor brought to class a black attaché case. He told the students that inside the case there was a small computer which was capable of producing the answer to any question anyone asked. "What questions," he asked, "do you want it to answer?"

The teacher rarely tells students what he thinks they ought to know.

His basic mode of discourse with students is questioning.

Generally, he does not accept a single statement as an answer to a question.

He encourages student-student interaction as opposed to student-teacher interaction. And generally he avoids acting as a mediator or judge of the quality of ideas expressed.

He rarely summarizes the positions taken by students on the learnings that occur.

His lessons develop from the responses of students and not from a previously determined 'logical' structure.

Generally, each of his lessons poses a problem for students.

He measures his success in terms of behavioral changes in students.

Perhaps you have noticed that most examinations and, indeed, syllabi and curricula deal almost exclusively with the past. The future hardly exists in school. Can you remember ever asking or being asked in school a question like "If such and such occurs, what do you think will happen?" A question of this type is usually not regarded as 'serious' and would rarely play a central role in any 'serious' examination. When a future-oriented question is introduced in school, its purpose is usually to 'motivate' or to find out how 'creative' the students can be. But the point is that the world we live in is changing so rapidly that a future-orientation is essential for everybody. Its development in schools is our best insurance against a generation of 'future shock' sufferers.

**Thinking About Using Pot**

*Marijuana is replacing sex as the big family flap item these days. Part of the problem is the lack of coherent information. Whether you think Pot Kills or Pot Saves all depends on who you believe. Here is a friendly no-bullshit booklet that don't take sides but do spell out basic information. It won't eliminate disputes about what's right; it may reduce argument about what's true.*

**Thinking about Using Pot**  
Tod H. Mikuriya, M. D.  
Andrew T. Weil, M. D.  
1969; 31 pp.

**\$1.00** postpaid

from:  
The San Francisco Psychiatric  
Medical Clinic  
1840 Grove Street  
San Francisco, CA 94117

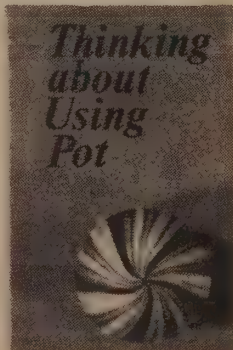

## Outward Bound

"I can't do that, I'll die."

But, if, for whatever horrid reason you do do it, and live, ah. Then right from your center out speculation is open about all the other things you knew you couldn't do.

This was one of the qualities of the Acid Tests administered by the Merry Parinksters. It was the only deeply useful thing I found in Ranger and Paratroop training in the Army. It looks to be the basic function of the Outward Bound school of the possible.

Tuition for 26 days of Outward Bound (schools in various harsh locations) is \$350-450 for people mid-teens to early twenties. There are courses for girls and older folks. According to a report in Reader's Digest, "No one who wants the Outward Bound course is denied for financial reasons." U. S. schools are at Concord, Mass., Morgantown, N. C., Denver, Colo., Minneapolis, Minn., and Eugene, Ore.

For information and application forms, write:  
Outward Bound, Inc.  
Andover  
Mass. 01810

### 26-DAY PROGRAM FOR ONE 12-STUDENT WATCH

DAY	0845-1030	1030-1215	1300-1545	1545-1730	1945-2100
1	Enroute to Rockland, Maine		12-mile boat trip to Hurricane Island	Issue Gear Quiet Walk	Director's Welcome Pledges
2	First Aid Lecture	Initiative Tests Ropes, Walls	Seamanship and Navigation Rowing Whaleboats		Navigation Lecture
3	Seamanship Small Sail Boats	Ecology First Field Trip	Drownproofing Introduction	Climbing Knots, Belays	Free Time/Duty Watch (duty watch begins at 2100)
4	DUTY WATCH: 24-hour manning of the Rescue Station and Radios Radio Procedures, Fire Fighting Techniques, Proper Use of Equipment, Weather, Logs, Mess Detail				
5	Sunday Meeting/ Free Time	Seamanship Peapods	Initiative Tests Ropes, Walls	Drownproofing Float Test	Artificial Respiration Lecture, Demonstration
6	Climbing Belaying, Scrambling	Drownproofing Practice tied up tests	Seamanship and Navigation Rowing Drills, Intro. to Sailing		Navigation Plotting Practice
7	Three Day - Planning a Cruise, Stowing and Checking a Boat Inventories, Camp Ashore at Night				
8	Training Cruise: Basic Campers Skills, Boat Watches Intensive Seamanship, Night Exercises				
9	In Whale Boats: Anchoring, Man Overboard Procedures, Rowing, Sailing Navigation, Return by 1730				
10	Climbing Rappelling, Practice Falls	Drownproofing Legs Tied Test	Seamanship and Navigation Drills without instructor		First Aid Lecture
11	Seamanship Capsize Drill	Ecology Field Trip (low tide)	Community Service	Drownproofing Arms Tied Test	Free Time Duty Watch
12	DUTY WATCH: 24-hour manning of the Rescue Station and Radios. Solo Briefing after 2100 Rescue Unit, Fire Fighting, Search Patterns, Mess Detail, Casualty Handling, Logistical Support				
13	Solo Drop Off on an Island				



## Humanitas Systems

John Holt recommended their Math Primer, so I wrote for it, and here came a catalog of very far out gear—a motion sensor (\$40), galvanic skin response meter (\$50), random light box (\$25), radar surveillance system (\$795), signal delay device (\$50), audible alpha wave sensor (\$225), and to be sure, a Math Primer (price unspecified). Prices on the electronic stuff look good. The curriculum stuff is still a mystery.

Catalog  
free

from:  
Humanitas Systems  
Green Valley School, Inc.  
Box 606  
Orange City, Florida 32763

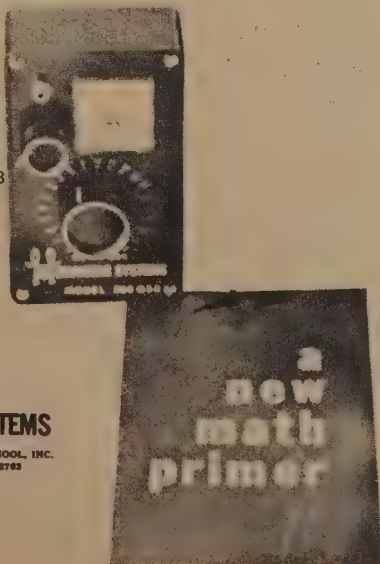

**HUMANITAS SYSTEMS**  
A DIVISION OF GREEN VALLEY SCHOOL, INC.  
BOX 606, ORANGE CITY, FLORIDA 32763

## Education Automation

In this book Fuller is mainly concerned with educational access: designing ready access to comprehensive and replicable information and designing mobility as the basis of education.

Education Automation  
R. Buckminster Fuller  
1962; 88 pp.

\$1.95 postpaid

from:  
Southern Illinois University Press  
600 West Grand  
Carbondale, Illinois 62903

or WHOLE EARTH CATALOG

I would say, then, that you are faced with a future in which education is going to be number one amongst the great world industries, within which will flourish an educational machine technology that will provide tools such as the individually selected and articulated two-way TV and an intercontinentally net-worked, documentaries call-up system, operative over any home two-way TV set.

We also find that generally speaking the geographically larger the physical task to be done, the duller the conceptual brain that is brought to bear upon the integration of the scientific discoveries and their technically realized applications. Finally, we get to international affairs, and you know what is happening today.

I would counsel you in your deliberation regarding getting campuses ready now to get general comprehensive environmental controls that are suitable to all-purposes like a circus. A circus is a transformable environment.

You don't need a detailed drawing; we do not make that kind of communication to a craftsman anymore; but all the schools go on teaching that we do. The data no longer goes to the craftsman; it goes to the tools. The idea of drafting measured details is going to become obsolete. We don't want any more measured detail drafting. What we want is the man who gets the fundamental concept, the information significance and can do some comprehensive thinking regarding that information. He will put the data into the information machines, and it will be processed by automation into physical realization of his effective thinking. We don't need many of the myriad of "things" we have had in schools.

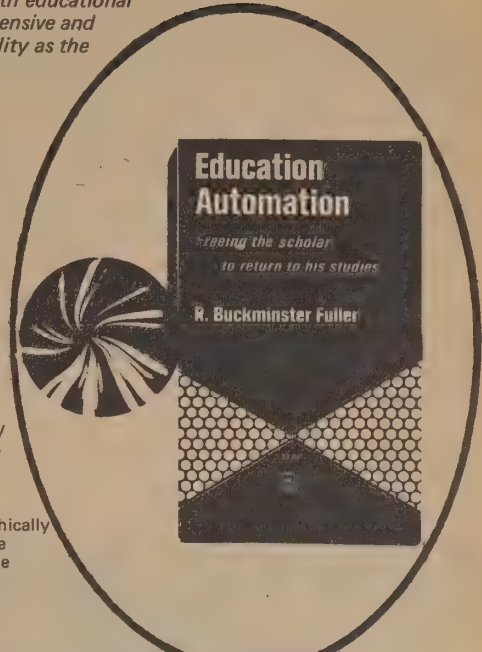

### Things A SCHOOL NEEDS

Desks, filing cabinets, sewing machines. Television, radios, photographs. Typewriters, DITTO machine. Stove, refrigerator, freezer. Heaters. Cameras (moving and candid), projectors and screens. Camping equipment, musical instruments. Darkroom equipment. Good pocketbooks. Arts and crafts supplies, science equipment. Kitchenware, cleaning equipment. Gardening tools, building tools and supplies. Garbage cans. All paper products. Sod. [New Directions Community School, Richmond, CA]



GOLEM (gō'lum)

### Kaiser Aluminum News

Don Fabun is doing very well at his job of making Kaiser appear comprehensive and futuristic. The Kaiser Aluminum News that he edits comes out several times a year, each issue devoted to one large topic, such as communication, transportation, food crisis, etc. They are excellent compendiums of current thought, vividly illustrated and laid out. Best of all, they're free if you write Kaiser for single copies.

Inquire for their list from:  
Public Affairs Department  
Kaiser Aluminum and Chemical Corporation  
Kaiser Center 866  
Oakland, California 94604

### NO WIPE OUT

The face of change is a young one—and it comes in many colors. All previous revolutions had, as their goal, the attainment of some new state of equilibrium. What we are seeing in our time is a new order of revolution, whose goal is not a new equilibrium, but social disorder itself. It is the first social recognition that continuous change itself is a form of equilibrium—and that it is only in disorder that we find order. These kids are "surfing" and it is the essence of surfing that one should ride the turbulence without succumbing to it. You cannot have fun surfing on a slow wave—and you cannot surf at all on a frozen one.

### THE SINGLE TRUTH

"One must work, if not from taste, then at least from despair. For, to reduce everything to a single truth: work is less boring than pleasure."

J. PIEPER

"Leisure, the Basis of Culture"



"Assuming that you have a normal pulse beat, it will not quite keep up with the increase in world population...Every time your pulse throbs, the population of the world will have added more than one human being."

WILLIAM VOGT  
"People!"



A compendium of 6 issues of Kaiser Aluminum News about the next 20 years has been published in hardcover under the title The Dynamics of Change. The book costs \$6.95 from Prentice-Hall, Englewood Cliffs, N. J. 07632.

**LIFE Science Library**

Generally, how much space we give an item is a measure of our regard for the item. This time we're enlarging the Science Library review because we feel even more strongly that it is an outstanding series. Most direct route to a handle on the slippery world. All of the books are well edited, illustrated and authored. You pick one up, and hours later you're still there on the john or wherever helplessly engrossed in a diagram explaining the design of musical instruments.

Most popular science books are badly behind the times. This series puts special emphasis on recent developments

The LIFE Science Library costs about \$4.50 per book, plus postage. You get on their list and they send you a book every month or so and you either send the book back or pay up. Some are better than others, but we haven't sent one back yet.

**LIFE Science Library**

from:  
Time-Life Books, Inc.  
Retail Sales Dept.  
540 N. Michigan Avenue  
Chicago, Illinois 60611



The Physician

**ATOMS FOR LIFE**

The skeleton shown here is outfitted with both an artificial heart (center) and a mock-up of a portable atomic-power pack (lower right). The pack is designed to hold radioactive materials that release heat to generate steam; the steam would drive the piston of a pump which in turn would create a regular beat in the synthetic heart, forcing blood to flow throughout the body.

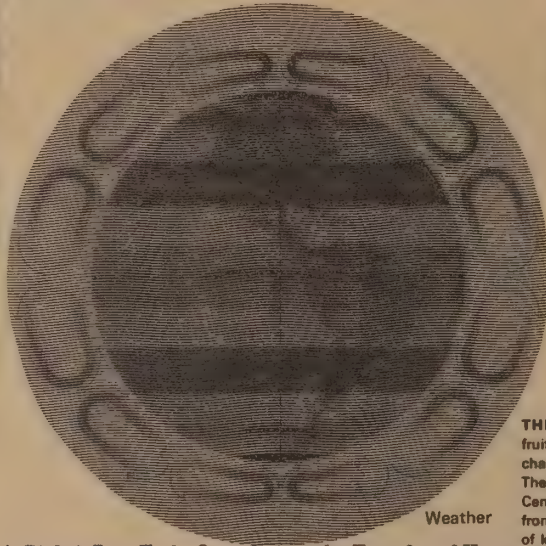

Weather

**A Global Gear Train Operated by the Transfer of Heat**



**WHAT'S WRONG WITH THIS PHRASE?**

At first glance, seemingly nothing. But with closer reading the repetition of the word THE becomes obvious. Because we generally read rapidly in word patterns rather than slowly a word at a time, it is easy for the eye to skip over the extra THE and register the familiar phrase "correctly."  
Light and Vision

Although Jupiter's cloud cover is constant, most of the cloud markings we see there are quite transient, and disappear after a few days or weeks. However, there is one puzzling formation which has remained visible, on and off, for at least 130 years. This is the famous Great Red Spot, an oval shaped mass lying parallel to the planet's equator and not far from it, in the Southern Hemisphere. The Great Red Spot is considerably larger than our entire earth, yet it drifts around Jupiter like a gigantic raft; it has made several revolutions of the planet during the century that it has been under intense observation. The most popular theory holds that the Great Red Spot is a huge meteorological disturbance.

While cooking makes protein, fat and carbohydrate foods far more useful to mankind, it does not do the same for the remaining two nutrient groups, the minerals and the vitamins. They would serve man better, in fact, if cooking had never been invented. They do not need to be cooked, for they are used by the body in almost the same forms they take in raw food, and cooking may deplete or destroy them. Cooking with bicarbonate of soda, which is often added to vegetables to improve their color, creates an alkaline solution that accelerates losses of vitamin C. Worst of all is the use of large amounts of water in cooking; the water dissolves, or leaches, essential minerals and vitamins and they are left behind in the pot.

The dangers of leaching were pointed out as recently as the 1920's, when public-health officials were puzzled by the strange pattern of malnutrition in the South. Impoverished sharecroppers there ate poorly—grits, corn mush and molasses, greens, with a bit of fatback. The diet for white and Negro sharecroppers was much the same. But, oddly enough, the whites suffered more severely from deficiency diseases; the Negroes, also ill-fed, were relatively unaffected. The mystery was not solved until the scientists learned that both whites and Negroes boiled their staple foods for long periods to improve the palatability of the somewhat tasteless provender. But then the whites threw away the cooking water; using the so-called potlikker was socially unacceptable. With the discarded liquid went the nutrients that had been leached away by long boiling. The Negroes, uninfluenced by the social stigma attached to potlikker, drank it and used it to soak corn bread, recapturing the essential vitamins and minerals.

Plants

**TWO LENSES IN ONE**

**Light and Vision**

Bifocals—introduced to America in the 18th Century by Benjamin Franklin—help older people with rigid lens structure to focus at both near and far distances. The upper half of the spectacle lens gives slight correction for distant viewing. The lower half is for close-up work; it provides the increased refraction needed to compensate for the increasing rigidity—and the inability to focus—of the aging lens.

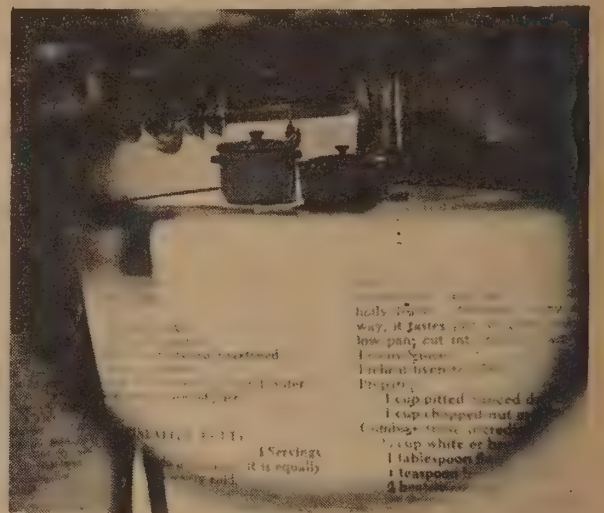

**PIECES OF A PICTURE**

The object of this perception test is to fill in the missing pieces so that a familiar picture appears. If the test remains puzzling at normal reading distance, try it again from three or four feet before looking at the answer.

A horse and rider.  
Light and Vision

**THE EVOLUTION OF CORN** to the modern fruitful version required 7,000 years of radical change, as indicated by these three samples. The inch-long ear of wild maize (left)—a Central American plant now extinct—dates from around 5200 B.C.; it has only eight rows of kernels with five to six kernels on each row. By 500 B.C., Mexicans were growing four-inch-long ears called Nal-Tel (center) that had some 11 rows of small kernels per cob. Today, one of the most widely cultivated corn plants in Mexico is Chalqueño (right), eight inches long, with 17 rows of narrow kernels.

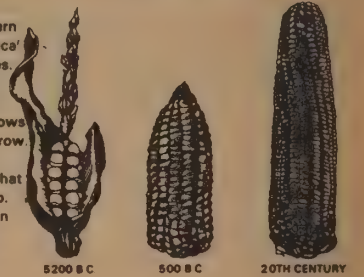

5200 B.C.

500 B.C.

20TH CENTURY

Plants

The complex oscilloscope trace reveals the immense number of components in a violin note. Despite its jagged appearance, the note does not sound jerky; the time interval between the large peaks is less than one five-hundredth of a second, and it is very much less than that between the smaller peaks.

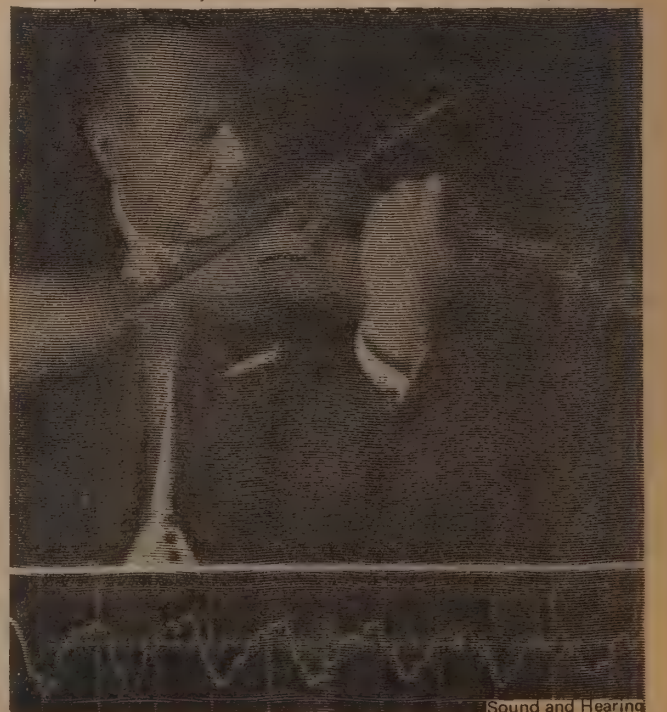

Sound and Hearing



This book grew out of a smaller volume called *Suggestions for Science Teachers in Devastated Areas* whose production was sponsored by UNESCO right after World War II. It was meant for use in schools whose buildings and labs had been destroyed and soon found its way into the hands of people who had never had these things to begin with. Thus it solves the problem of schools, communities—people—who want to do 'live' science without money or equipment. There isn't any experiment in it which would be too costly for any of us to do. The book tells you how to put together the equipment you need: real clever ways of making glass cutters, balances, burners, telescopes, microscopes, etc. A lot of what you need to do the experiments is just stuff you'd have around the house. The rest can be gotten [very low cost stuff] at the drugstore, hardware, junk yard, etc.

Also the book is unusually well written. There's no bullshit in it and it doesn't talk down to the reader. Just very straightforward instructions with illustrations that are highly readable. In most cases you aren't told the outcome of the experiment, an aspect which makes you much more interested in doing it.

[Reviewed by Jane Burton]

700 Science Experiments for Everyone  
1958; 250 pp.

\$4.50 postpaid

from:  
Doubleday & Company, Inc.  
501 Franklin Avenue  
Garden City, L.I., N.Y. 11531

or WHOLE EARTH CATALOG

or Edmund Scientific

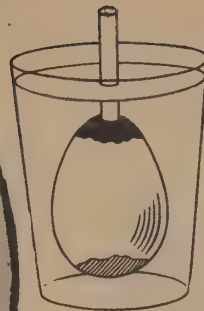

**An egg osmometer**

Place some dilute hydrochloric acid or strong vinegar in a shallow dish, such as a saucer, to a depth of about one centimetre. Hold the large end of an egg in the acid until the shell has been eaten away on the end leaving the thin membrane exposed. Rinse the acid from the egg. With a sharp instrument work a small hole through the shell at the other end. Insert a soda straw or a length of glass tubing through the hole into the interior of the egg. Seal the opening around the tube with household cement or sealing wax. This must be absolutely tight. Place the osmometer in a glass of water and let it stand for a few hours.

**Making smoke prints of leaves**

Smoke prints of leaves may be easily made by following the four steps shown in the diagrams.

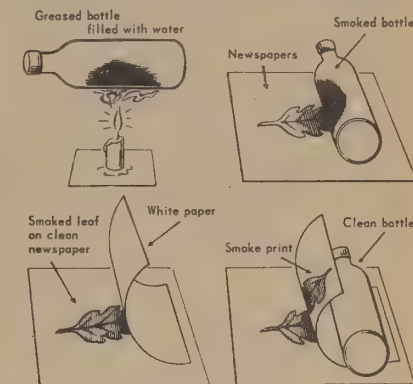

**Another way to show that water pressure increases with depth**

Find a tall tin can. Punch holes up the side of the can about 3 cm apart. Put a strip of adhesive or plastic tape over the row of holes and fill the can with water above the top hole. Hold the can over a sink and strip the tape from the holes beginning at the bottom. Observe the streams and note the distances travelled outwards from the can.

**Water pressure is the same in all directions**

Punch holes around the base of a tall tin can with a nail. Cover the holes as above with a strip of tape. Fill the can with water and strip off the tape while holding it over a sink. Observe and compare the distance the streams shoot out from the holes all around the can.

**Edmund Scientific**

Edmund is the best source we know of for low-cost scientific gadgetry (including math and optics gear). Many of the items we found independently, such as Dr. Nim, 700 Science Experiments, Geo-D-Stix, Spilhaus Space Clock, etc., turned up in the Edmund Catalog, so we were obliged to recognize that in this area we've been preceded. They list 4,000 items, they ship, and their catalog is free.

**EASILY BEND WIRE INTO USEFUL SHAPES**

Turn wire, coat hangers, etc. into peg board hardware, stakes, springs, tools, toys, art. Cast aluminum jig with cutting blade, fulcrum & bending pins handles up to 1/4" steel wire. 100 illustrated projects.

No. 40,870 \$2.00 Ppd.

Order from:  
Edmund Scientific Company  
100 Edscorp Building  
Barrington, N. J. 08007

**HAVE FUN WITH SCIENCE OF SOAP BUBBLES**

Create endless complex shapes, study and enjoy their fascinating behavior. Learn about liquid skins, pressures, jets, electrical conduction and the membrane theory of stress distribution. Chemist designed kit includes special, longer-lasting, lower-cost bubble formulation (makes several gallons). Sticks with poly connectors and wire bending jig to make bubble frames, plus 190-pg. book on subject by C. V. Boys. Complete instructions. No. 70,742 \$6.00 Ppd. Formulation only. No. 40,782 \$3.00 Ppd.

**"THINK STICKS" THE MODERN KITS FOR INDUSTRIAL, EDUCATIONAL, FUN USES... VISUALIZE IN 3 DIMENSIONS**

Here is the ideal visualizing and demonstration tool for teachers; learning aid for students in mathematics, physics, chemistry, design, and architecture. Excellent for Science Fair projects. Hobbyists and artists find them fascinating and extremely useful.

In mathematics, Think-Sticks Kits are used to construct geometric figures ranging from triangles and cubes to such multiple sided figures as icosahedrons and dodecahedrons. In design classes, models are made to determine functional and esthetic efficiency. Architectural and engineering instructors mock up girders, trusses, towers, frameworks; and demonstrate the nature and effect of stress. The State University of Washington, for example, is now using these in its Architectural and Engineering Laboratories.

Professional uses aside, Think-Sticks open new horizons of fun, knowledge and experimentation for any youngster. Ease of use and durability make Think-Sticks much superior to old-fashioned wood or metal kits. 1/4" diameter plastic or birch sticks fit smoothly into 1" polyethylene joints having 1/4" sleeves—form rigid structures. (Connectors can now be bought separately. T-connector supplied only with KIT No. 70,211.) Complete instructions included. Money-back guarantee.

**KIT No. 70,209.** Ideal introductory set. 220 pieces... 5, 6, & 8-sleeve connectors; 2, 3, 4, 5, 6, and 8" colored Think-Sticks. For all geometric structures and many artistic designs. \$3.00 Postpaid

**KIT No. 70,210.** Ideal for assembly of models, transmission towers, and for anyone with advanced interests. 370 pieces including 5, 6, 8-sleeve connectors; 2, 3, 4, 5, 6, 8, 10 and 12" colored Think-Sticks. Complete kit. \$5.00 Postpaid

**KIT No. 70,211.** Adequately fills the needs of schools, architects, designers, any group at the professional level. 452 pieces include 5, 6, and 8-sleeve; and T-connectors. (T-connector allows Think-Stick to pass clear through); 2, 3, 4, 5, 6, 8, 10 and 12" colored Think-Sticks; and long length of unpainted Think-Sticks which can be cut to any size required for your own designs. \$7.00 Postpaid



**SEPARATE CONNECTORS, UNPAINTED STICKS**

No.	Type	Pkg. of	Price
P-60,108	(A) 5-sleeve	50	\$2.45 Ppd.
P-60,109	(B) 6-sleeve	50	2.45 Ppd.
P-60,110	(C) 8-sleeve	50	2.45 Ppd.
P-60,111	(D) T-conn.	50	2.45 Ppd.
P-60,112	24" Sticks	100	2.00 Ppd.

**SPILHAUS SPACE CLOCK—WORLD'S MOST INFORMATIVE CLOCK**

Dr. Spilhaus, one of America's leading scientists, took 5 years to develop this space-age astronomical clock. Large top dial has 5 transparent overlay discs. Four, rotating independently, combine with the fixed disc to capture the depth of the night sky and automatically show you 19 up-to-the-minute pieces of information related to time, the moon, sun, stars and tides.

- Read Top 8 1/2" Dial for...
1. The horizon and the visible heavens
  2. The sun's position in the sky
  3. Moon's position
  4. Position of the stars
  5. Relative positions of sun, moon & stars
  6. Day, month, year. A perpetual calendar
  7. Meridian solar-time of sun, moon & stars
  8. Sidereal or star time (used with tables)
  9. Current phase of the moon
  10. Time of daily sunrise and sunset
  11. Mean time of moonrise and moonset
  12. Mean time of star-rise and star-set
  13. Current time of high or low tide
  14. Current stage of the tide
  15. Mean solar time

**HOME SCHOOL OFFICE STORE LIBRARY CLUBROOM**



A SPACE AGE INFORMATION CENTER  
UNIQUE GIFT, PRESENTATION OR AWARD  
OUTSTANDING SCHOOL TEACHING AID

An up-to-the minute encyclopedia of the skies for the home... for amateur astronomers, space enthusiasts, fishermen, boat and aircraft owners, shore residents, teachers, scientists. No. 1202. \$250.00 Trans. Chg. Coll. Also available nationally through selected dealers.

- Lower Left 4" Dial shows...
16. Ordinary or zone time
- Lower Right 4" Dial shows...
17. 24-hour time
  18. Universal or Greenwich Mean Time
  19. Time in major cities of USA and world (L.M.T.).

**Elementary Science Study**

ESS has developed (and is developing), a number of interesting science units for elementary-school-age children. Some of these are in commercial publication through McGraw Hill. Others are in the form of highly informative and useful "working papers" available from ESS for nominal fees (i.e. \$.50). Even some of the commercial stuff is cheap. Those units—and there are several—requiring only teacher's manuals and some ingenuity in locating materials are frequently the most interesting and the cheapest. The manuals are usually \$1 or \$1.50. In addition ESS will send you their free newsletter. It usually has some feedback reports on the success (or lack of it) of their Science materials, good recommendations of books and stuff in the field of education, news of interesting projects tried by individual science teachers, and advance notice about ESS research. For any of the above, write to:

Elementary Science Study  
Education Development Center, Inc.  
55 Chapel Street  
Newton, Mass. 02160

[Suggested and reviewed by Mrs. W. B. Mohin]



The commercial ESS materials (as well as materials of Experiences in Science: Time, Space, and Matter; and Fossils) are described and listed in the McGraw-Hill Science Materials Catalog, available

from:  
Webster Division  
McGraw-Hill Book Company  
Manchester Road  
Manchester, Mo. 63011

**Patterns of Survival**

As far as I'm concerned education and evolution are conceptually indistinguishable. If you know how to evolve you're ahead of whatever game is going. For example, the way to be safe from dinosaur bites is to be little, fast, furry, warm-blooded, and smart. (The way to be in hazard of dinosaur bites is to be another dinosaur.) We're talking about education in the school of survival, which every school is, despite pastel walls.

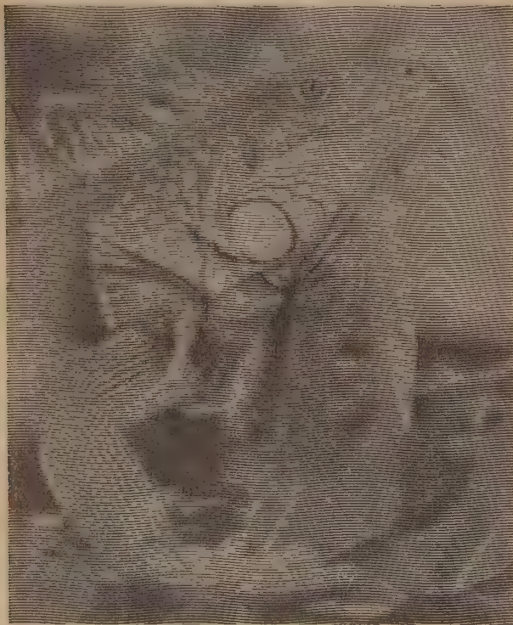

This well-illustrated and personal book is the best introduction I've seen to the fascination of evolutionary perspective on the living and dying world we take part in.

We remember that Nietzsche said: "In the architectural structure, man's pride, man's triumph over gravitation, man's will to power, assume a visible form." But should we now go the extra step and imitate the successful corals? From them we could learn that defense against gravity is not enough to give us power for survival. We might build into our urban architecture an added wealth of plant partners to clean the air and give us extra food. Perhaps rows of wheat plants and a potato vine should join the geranium flowering on the window sill, as a first step in the right direction.

Flea powders containing poison deadly to adult fleas were puffed into the dirty clothing and dirty homes where the parasites were numerous. But poison proved to be just a new kind of dirt. It killed only 99 percent of the fleas, or slightly more. A few of the parasites were resistant, and so were their offspring. In just a few years the fleas became as numerous as ever and virtually immune to the poison in concentrations that previously had seemed effective. So long as the creature survives, it still has a chance to evolve a little more and make a comeback everywhere.

Not so very long ago the eminent British biologist Joseph Bancroft of Cambridge University set down his thoughts on what he called Features in the Architecture of Physiological Function. He was impressed by the number of ways in which living things have escaped "from the tyranny" of the chemical rule shown by the equation of Arrhenius. He saw how far-reaching was the change when, instead of just slowing down as the weather chilled, the ancestors of mammals and birds began to shiver inside their coats of fur and feathers. Here was "the cold-blooded animal successfully adopting ingenious mechanisms, first biochemical, then physiological, in order to adapt its heart to the variations of its environment; the warm-blooded animal discarding what its cold-blooded predecessor has laboriously beaten out, invoking the nervous system to reverse the normal biochemical relationship and gaining a new freedom by adapting, not itself to the internal environment, but the internal environment to itself."

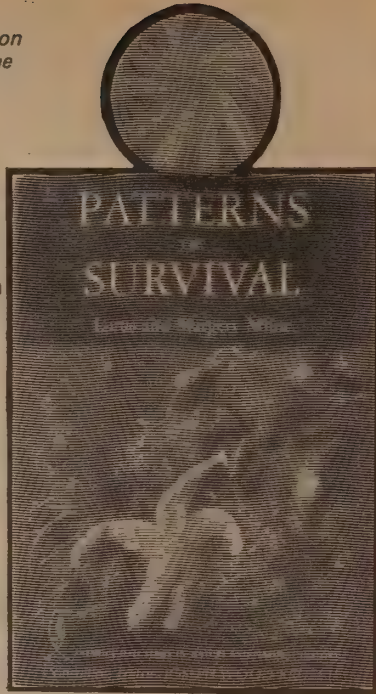

**Patterns of Survival**  
Lorus and Margery Milne  
1967; 339 pp.  
\$7.95 postpaid

from:  
Prentice-Hall  
Englewood Cliffs, N. J. 07632  
or WHOLE EARTH CATALOG

**Follow Through Project**

Education Development Center has far the best list we've seen of recommended instructional aids, materials, and supplies for the primary grades. Prices and suppliers are given with the items. The list (36 pp.) apparently is free.

[Suggested by John Holt]

from:  
Follow Through Project  
Educational Development Center  
55 Chapel Street  
Newton, Mass. 02160

**The Web of Life**

A good anecdotal introduction to ecology.

**The Web of Life**  
John H. Storer  
1953, 1956; 128 pp.

\$ .95 postpaid

from:  
New American Library  
1301 Avenue of the Americas  
New York, N. Y. 10019

or WHOLE EARTH CATALOG

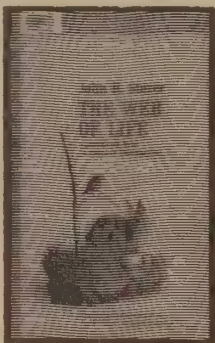

In the White River National Forest in Colorado a heavy wind blew down several groups of Englemann spruce trees. It broke many of the tree roots, weakening the flow of sap, but left enough roots in the ground to keep the trees alive. Thousands of beetles gained entrance to these weakened trees and found a paradise to work in; for the underside of each tree, buried in a mat of crushed branches, was protected from the hunting woodpeckers. The most effective of these woodpeckers, the arctic three-toed, hunts this area chiefly in winter, but now, with the fallen trees covered by snow, the beetles were completely safe from their chief enemy and they multiplied.

First they killed the fallen trees. Then the dead trees became a focus of infection for the surrounding forest, as more beetles in search of food attacked the healthy trees nearby. The potent sap of these growing trees drove out the first attackers, but millions more followed, puncturing the bark and weakening the sap flow until later hordes gained easy entrance. These swarms outgrew the appetites of the woodpeckers, whose numbers were adjusted to a normal beetle population.

In a few years the entire forest, covering many thousands of acres, was dead or dying. Four thousand million board feet of timber stood rotting where it died, most of it wasted; for in this rough mountain country it was not worth building roads to bring it out. There was no young, productive forest left to justify the cost of these roads.

The entire forest was doomed, and all the great dependent community of living things had lost its food and shelter. This community too must go, simply because one of its smallest members had escaped its natural controls and found too much prosperity.

**Andrew Lang Fairy Books**

Everybody suggests these books, but nobody wants to review them, which I take as a good sign: it's too rich a bundle to bag. I haven't read the series. I have been paging through, and it's clear the stories (gathered and published by Andrew Lang around 1905) are made of meat and potatoes and starvation and eagles and ladies and hermits and ogres and hard changes and not cotton candy. The turn-of-century illustrations by H. J. Ford are romantic.

[Suggested by Holly Baer]



"Someone has told the king that I have prophesied that a child shall be born this night in the palace, who can speak all the languages in the world and play every musical instrument. I am no magician to bring these things to pass, but he says that if it does not happen he will have me dragged through the city at a horse's tail till I die."

"Do not trouble yourself," answered the stork. "I will manage to find such a child, for I am the king of the storks whose life you spared, and now I can repay you for it."

There was once a king's son who told his father that he wished to marry.

- THE BLUE FAIRY BOOK. 37 tales. 8 plates. 130 additional illustrations. ix + 390pp. 5 1/2 x 8 1/2. Paperbound \$1.75
- THE GREEN FAIRY BOOK. 42 tales. 13 plates. 87 additional illustrations. xiii + 386pp. 5 1/2 x 8 1/2. Paperbound \$1.75
- THE BROWN FAIRY BOOK. 32 stories. 30 plates, 8 in color. 20 additional illustrations. xii + 350pp. 5 1/2 x 8 1/2. Paperbound \$1.75
- THE YELLOW FAIRY BOOK. 48 tales. 22 plates. 82 additional illustrations. xviii + 321pp. 5 1/2 x 8 1/2. Paperbound \$1.75
- THE VIOLET FAIRY BOOK. 35 tales. 41 plates, 8 in color. 33 additional illustrations. xii + 388pp. 5 1/2 x 8 1/2. Paperbound \$1.75
- THE RED FAIRY BOOK. 37 tales. 4 plates. 93 additional illustrations. x + 367pp. 5 1/2 x 8 1/2. Paperbound \$1.75
- THE PINK FAIRY BOOK. 41 tales. 34 plates. 38 additional illustrations. xii + 360pp. 5 1/2 x 8 1/2. Paperbound \$1.95
- THE CRIMSON FAIRY BOOK. 36 stories. 43 plates, 8 in color. 10 additional illustrations. xii + 371pp. 5 1/2 x 8 1/2. Paperbound \$1.95
- THE GREY FAIRY BOOK. 35 tales. 32 plates. 28 additional illustrations. xiv + 387pp. 5 1/2 x 8 1/2. Paperbound \$1.75
- THE LILAC FAIRY BOOK. 33 stories. 26 plates, 6 in color. 28 additional illustrations. xiv + 369pp. 5 1/2 x 8 1/2. Paperbound \$1.95
- THE OLIVE FAIRY BOOK. 29 stories. 28 plates, 8 in color. 22 additional illustrations. xv + 336pp. 5 1/2 x 8 1/2. Paperbound \$1.75
- THE ORANGE FAIRY BOOK. 33 stories. 25 plates, 8 in color. 33 additional illustrations. xiv + 358pp. 5 1/2 x 8 1/2. Paperbound \$1.95

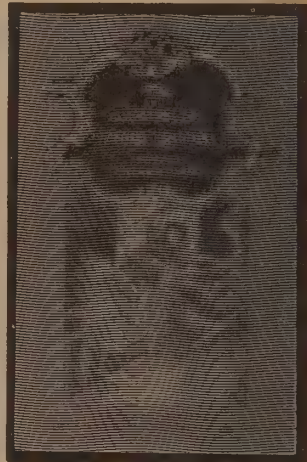

from:  
Dover Publications, Inc.  
180 Varick Street  
New York, N. Y. 10014

or WHOLE EARTH CATALOG

Among the mountain pastures and valleys that lie in the centre of France there dwelt a mischievous kind of spirit, whose delight it was to play tricks on everybody, and particularly on the shepherds and the cowboys. They never knew when they were safe from him, as he could change himself into a man, woman or child, a stick, a goat, a ploughshare. Indeed, there was only one thing whose shape he could not take, and that was a needle. At least, he could transform himself into a needle, but try as he might he never was able to imitate the hole, so every woman would have found him out at once, and this he knew.

**Guinness Book of World Records**

Guinness Book of World Records

\$1.00 postpaid

from:  
Bantam Books, Inc.  
271 Madison Ave.  
New York, N. Y. 10016

or WHOLE EARTH CATALOG

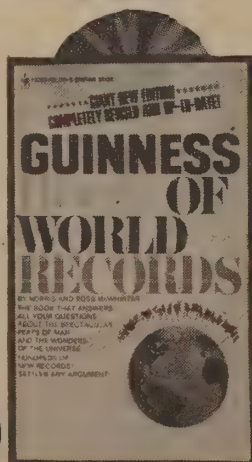

An astonishing amount of conversation in the Western World is spent agreeing or disagreeing on the extremes of experience. Maybe it's some primordial urge to know where we are in the universe. Whatever, it's deep. This book is automatic conversation; whoever's reading it has to start reading aloud. And whoever's around to listen and respond. Weird. Painless education though.

**Highest Income.** The highest gross income ever achieved in a single year by a private citizen is an estimated \$105,000,000 in 1927 by the Chicago gangster Alphonse ("Scarface Al") Capone (1899-1947). This was derived from illegal liquor trading and alky-cookers (illicit stills), gambling establishments, dog tracks, dance halls, "protection" rackets and vice. On his business card Capone described himself as a "Second Hand Furniture Dealer." Henry Ford, the first (1863-1947) earned about \$70,000,000 per annum at his peak.



**HIGHEST HABITATION:** This "silver hut," a prefabricated laboratory erected at an altitude of 18,765 feet in the Ming Bo Valley of the Himalayan mountains of India, was inhabited for four months in 1960-61.

**Lowest Incomes.** The poorest people in the world are the 42 surviving Pintibu (or Bindibu) found in the Northern Territory of Australia in July, 1957. They subsist with water from soak holes and by eating rats. In September, 1957, Chinese Government sources admitted that in some areas of the mainland the average annual income of peasants was 42 yuans per head. In 1964, China's average income per head was estimated at \$70 and the daily caloric intake at 2,200 (see page 298 for highest intake).

**Return of Cash.** The largest amount of cash ever found and returned to its owners was \$240,000 in unmarked \$10 and \$20 bills found in a street in Los Angeles, by Douglas William Johnston, an unemployed Negro, in March, 1961. He received many letters, of which 25 per cent suggested that he was insane.

**Handshaking.** The world record for handshaking was set by Theodore Roosevelt (1858-1919), as President of the U.S.A., when he shook hands with 8,513 people at a New Year's Day White House Presentation on January 1, 1907. Outside public life, the record is 37,500 hands in 7 hours 15 minutes 18 seconds by George Borkowski, in London on February 22, 1967.

**Pill Taking**  
It is recorded that among hypochondriacs Samuel Jessup (born 1752), a wealthy grazier of Heckington, Lincolnshire, England, has never had a modern rival. His consumption of pills from 1794 to 1816 was 226,934, with a peak annual total of 51,590 in 1814. He is also recorded as having drunk 40,000 bottles of medicine before death overtook him at the surprisingly advanced age of 65.

**Hiccoughing**  
The longest recorded attack of hiccoughs was that afflicting Jack O'Leary of Los Angeles. It was estimated that he "hicked" more than 160,000,000 times in an attack which lasted from June 13, 1948, to June 1, 1956, apart from a week's respite in 1951. His weight fell from 138 lbs. to 74 lbs. People sent 60,000 suggestions for cures, of which only one apparently worked—a prayer to St. Jude, the patron saint of lost causes.

**Sneezing**  
The most chronic sneezing fit ever recorded was that of June Clark, aged 17, of Miami, Florida. She started sneezing on January 4, 1966, while recovering from a kidney ailment in the James M. Jackson Memorial Hospital, Miami. The sneezing was stopped by electric "aversion" treatment on June 8, 1966, after 155 days. The highest speed at which expelled particles have been measured to travel is 103.6 m.p.h.

# Previously listed in Learning and still beloved:

## Self-Hypnosis

A guy from Stanford named Bob Lochridge came into the Truck Store, saw Lecron's Self Hypnotism and said that it was sure enough a good book about self-hypnotism, but for technique we'd be better off with Sparks' Self-Hypnosis. So we are.

[Suggested by Bob Lochridge]

Self-Hypnosis  
Laurance Sparks  
1962; 254 pp.

\$2.00 postpaid

from:  
Wilshire Book Company  
8721 Sunset Boulevard  
Hollywood, CA 90069

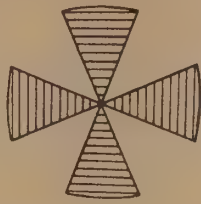

or WHOLE EARTH CATALOG

## Pre-Trance Instructions

1. While in a comfortable place and with eyes fixed straight ahead:
2. Think of the time you wish to "wake up."
3. Formulate your suggestion.

## Trance-Induction Procedure

3. Imagine "1000-1", the symbol for evoking tiredness of the eyelids.
4. Imagine "1000-2", the symbol for evoking eye-closure.
5. Imagine "1000-3", the symbol for relaxation.
6. Imagine "1000-4", the symbol for emotional tranquility.
7. Imagine "1000-5", the symbol denoting "hyper-suggestibility."
8. Imagine a circle enclosing an "X," then carefully erase the "X."

## Deepening Procedure

9. Imagine, one by one, the letters of the alphabet, as if writing "a" in the circle, then erasing it, etc.

## The English Duden

"One picture is worth a thousand words." The Germans believe that too, and proof is available in The English Duden. This is a short, fat, 928 page book that includes a picture of almost anything you can think of, and many things that you can't. Most of the illustrations are in black and white, but a number (including good ones of the human body) are in color. All are meticulously drawn and have every single constituent carefully and accurately labeled. The comprehensiveness of the book is staggering. It offers, with Teutonic omniscience, pictures showing every part of, say, a motorcycle engine, a paper-making factory, a handsome young lady, and the interior of a barber shop. Dress styles, beehives, photographic laboratories, musical instruments, Roman gods, jet aircraft; they are all here, clearly dissected and indexed in German and English (or French or Italian if you prefer), with differences between British and American usage noted. It is one of the publishing bargains of the 20th Century.

[Suggested and reviewed by Dr. Morton Grosser]

The English Duden  
1960; 928 pp.

\$5.55 postpaid from:

Adler's Foreign Books, Inc.  
162 Fifth Avenue  
New York, N. Y. 10010

The Basket-maker

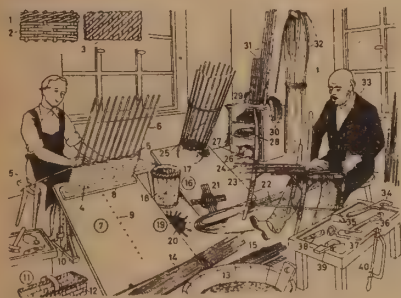

- 1-40 basket-making (basketry, basket-work).
- 1-4 weaving patterns:
- 1 the pairing
- 2 the slewing
- 3 the oblique randing
- 4 randing, a piece of wickerwork (of screen work):
- 5 the horizontal rod (weft)
- 6 the stake (sail, upright rod, warp)
- 7 the working board:
- 8 the transverse ledge
- 9 the hole to fix the ledge in;
- 10 the stand
- 11 the chip basket:
- 12 the chip;
- 13 the soaking tub
- 14 the one-year willow sticks (willow twigs; osier sticks, osier twigs)
- 15 the three-year willow rods (osier rods)
- 16 the basket, a piece of wickerwork (basket work):
- 17 the rim (border)
- 18 the woven side;

- 19 the slath;
- 20 the woven bottom;
- 21 the bottom cross
- 22 24 covering a frame:
- 22 the frame
- 23 the end
- 24 the strut;
- 25 the framework
- 26 the grass; sorts: esparto grass, alfalfa grass
- 27 the rush (China rush string)
- 28 the reed (reed mace, club rush)
- 29 the ratina (ratina, bast)
- 30 the straw
- 31 the bamboo cane
- 32 the rattan (ratan)
- 33 the basket-maker
- 34 the bending tool
- 35 the cutting point
- 36 the rapping iron
- 37 the pinners
- 38 the scraper
- 39 the basket-maker's plane
- 40 the bow saw

## Scientific American Offprints

Consistently the best science writing and illustrating appears in Scientific American. For 20¢ (2/ in England) you can get a full color copy of any article. The catalog of offprints is well organized and gives a good capsule description of each article (700 to choose from).

[Suggested by Jane Burton]

## Catalog

free from:  
W. H. Freeman & Company  
660 Market Street  
San Francisco, CA 94104

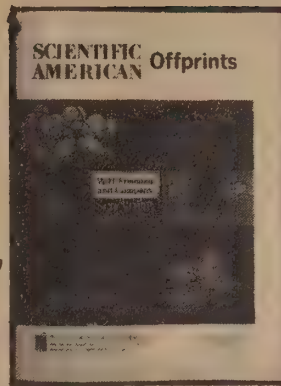

George W. Gray THE ULTRACENTRIFUGE  
George W. Gray ELECTROPHORESIS  
Curtis A. Williams, Jr. IMMUNOELECTROPHORESIS  
Mary A. B. Brazier THE ANALYSIS OF BRAIN WAVES

Leonard Berkowitz THE EFFECTS OF OB-  
SERVING VIOLENCE

Frank Barron, Murray E. Jarvik & Sterling Bannell, Jr. THE HALLUCINOGENIC DRUGS  
John R. Nichols HOW OPIATES CHANGE BEHAVIOR

Lawrence Zelic Freedman "TRUTH" DRUGS  
Burke M. Smith THE POLYGRAPH  
John B. Calhoun POPULATION DENSITY AND SOCIAL PATHOLOGY

Robert Rosenthal & Lenore F. Jacobson TEACHER EXPECTATIONS FOR THE DISADVANTAGED  
Marshall D. Sahlins THE ORIGIN OF SOCIETY

Walter McDermott AIR POLLUTION AND PUBLIC HEALTH  
A. J. Haagen-Smit THE CONTROL OF AIR POLLUTION

William L. Langer THE BLACK DEATH  
Bernard Berelson & Ronald Freedman A STUDY IN FERTILITY CONTROL

Charles F. Hockett THE ORIGIN OF SPEECH  
William W. Howells THE DISTRIBUTION OF MAN

Robert J. Braidwood THE AGRICULTURAL REVOLUTION  
Robert M. Adams THE ORIGIN OF CITIES  
Herbert Butterfield THE SCIENTIFIC REVOLUTION

Edward S. Deevey, Jr. THE HUMAN POPULATION OF MAN  
Theodosius Dobzhansky THE PRESENT EVOLUTION OF MAN

John Napier THE ANTIQUITY OF HUMAN WALKING  
Harald Eech THE EVOLUTION OF BEE LANGUAGE

Sherwood L. Washburn TOOLS AND HUMAN EVOLUTION  
It is now clear that tools antedate man, and that their use by prehuman primates gave rise to Homo sapiens. September 1960

Johannes A. Kylstra EXPERIMENTS IN WATER-BREATHING  
If the lung of an air-breathing animal (including man) is filled with the appropriate solution, the animal can obtain the oxygen necessary to sustain life. The procedure holds promise for medicine and diving. August 1968

Arthur Kornberg THE SYNTHESIS OF DNA  
Test-tube synthesis of the double helix that controls heredity climaxes a half-century of effort by biochemists to re-create biologically active giant molecules outside the living cell. October 1968

Annemarie de Waal Malefijt HOMO MONSTROSUS  
For 2,000 years most educated men believed that remote areas were inhabited by monstrous races. It was only with the 19th century that it became clear that there was only one species of living men. October 1968

W. Ehrenberg MAXWELL'S DEMON  
This hypothetical being, invoked by James Clerk Maxwell nearly a century ago as a violator of the second law of thermodynamics, has occupied the minds of many prominent physicists ever since. November 1967

Martin Gardner CAN TIME GO BACKWARD?  
It seems intuitively plausible that it can, but the concept creates a variety of paradoxes. For example, a time-reversed galaxy would be invisible to us because light would flow into it instead of out. January 1967

Walter M. Elsasser THE EARTH AS A DYNAMO  
Why is the earth a magnet? The best answer at present is that the slow flow of matter in its fluid core generates electric currents, which in turn set up a magnetic field. May 1958

Fritz W. Went THE ECOLOGY OF DESERT PLANTS

## Paper Airplane Book

"If we knew what it was we would learn, it wouldn't be research, would it?" was the title of an ad for Scientific American's project of an international paper airplane competition. The 20 winners are photographed in full page aeronautical glory followed by a tear-out pattern for imitations. No materials are needed other than the basic one referred to in the dedication —

The authors wish to dedicate this manuscript to Capt. Fear God Bascomb, out of New Bedford, Massachusetts, who brought the first known pad of lined 8 x 11" paper from China on May 1, 1743. It may well be said of Capt. Bascomb that without him, the paper airplane as we know it would not have been possible.

and scissors and infinite doodling type patience. As a school librarian with only two copies of this wildly popular book, I was finally reduced to tearing it up page by page for an eye level wall long display for group reading and a handy supply of tracing paper for pattern copiers. Our airborne climax was the North Hillsborough, California School Paper Airplane Olympics with appropriate contests and flyers, after which we were able to cross the school campus without shuffling ankle deep in aborted and/or terminated flight materials. The school custodian was one of the few associates not turned on by this librarian's flight of fancy (or reason, depending on your bias).

[Reviewed by Carol Guyton Goodell]

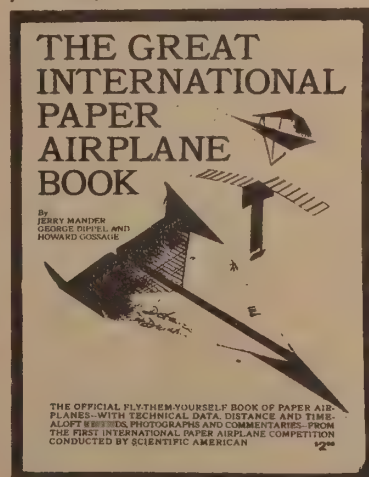

The Great International Paper Airplane Book  
Jerry Mander, George Dippel, and Howard Gossage  
1967; 128 pp.

\$2.95 postpaid

from:  
Simon & Schuster, Inc.  
1 West 39th Street  
New York, N. Y. 10018

or WHOLE EARTH CATALOG

## An Introduction to Scientific Research

A practical guide for the scientific experimenter, covering experimental planning, design of apparatus, and analysis and reporting of results. Basic general information applicable to many fields. Extensive lists of references for further information. The book is clearly written and surprisingly enjoyable reading.

[Reviewed by Larry McCombs]

There is a story of an industrialist who was unable to duplicate in a branch factory the manufacture of a chemical in a desirable crystal form. On further investigation of the process in the main plant, he found it in charge of an elderly employee who had always operated it, apparently with a perfectly simple routine. Closer examination, however, revealed that at one stage he always injected tobacco juice into the vat. This was the missing step, presumably because of surface active ingredients which influenced the growth habits of the crystals.

The overconservative scientist will pass by the new phenomena; the overenthusiastic one will endow commonplace events with world-shaking interpretations. Herein lies one good reason for understanding an apparatus and its quirks thoroughly. The momentary signal on the cathode-ray screen may be worth a Nobel prize; but it may also be the thermostat turning on the room heat.

## An Introduction to Scientific Research

E. Bright Wilson, Jr.  
1952; 373 pp.

\$2.95 postpaid

from:  
McGraw-Hill Book Company

Princeton Road  
Hightstown, N. J. 08520

Manchester Road  
Manchester, Missouri 63062

8171 Redwood Highway  
Novato, CA 94947

or WHOLE EARTH CATALOG

## Using Libraries Effectively

Every idiot should know how to use a library. (This idiot had to graduate from college before really learning.) Here's a simple book that covers the ground nicely, from how to look up anything to all the reference books you can expect to find. A library is such a handy handy handy handy thing.

## Using Libraries Effectively

Brogan and Buck  
1969; 116 pp.

\$1.95 postpaid from:

Dickenson Publishing Company  
Belmont, CA 94002

or WHOLE EARTH CATALOG

## Sense Relaxation

This is a book which is an experience while it teaches you how to have additional experiences. It is a combination of simple straightforward how-to-do-it prose broken by puns (to slow down your reading) plus sensual photographs of every exercise. Your first time through this book you will only glance at the words; the pictures are so compelling. The second and third times through you will read individual sections to find out what the pictures suggest. Finally you will begin to use this book to add touch, relaxation and pleasure to your life. This book gives very specific and easily followed exercises for individuals, couples, and groups to tune in to their own bodies and to all their senses. Gunther gives suggestions and techniques to energize, to tranquillize, and above all to increase awareness. It is a beautifully designed and executed book.

[Reviewed by James Fadiman]

## Sense Relaxation — Below Your Mind

Bernard Gunther  
Photographed by Paul Fusco  
1968; 191 pp.

\$2.95 postpaid

from:  
Collier Books  
866 Third Avenue  
New York, N. Y. 10022

or WHOLE EARTH CATALOG



**Fundamentals of Yoga**

Mishra has practised as general physician, surgeon and endocrinologist in India and the West and has a thorough knowledge of Western medicine as well as yoga. This makes his book invaluable to the student desiring a detailed scientific understanding of yogic theory and methods. The book contains several interesting diagrams of physical systems and psycho-physical planes of consciousness.

Being a practising teacher of yoga, Mishra writes in a forthright direct style and gives, in each chapter, exercises arranged in numbered steps, to practice the methods described. The physical, or hatha yoga methods are described in some detail, though still only as preparatory to the other meditative types of exercises. Methods not usually described in other works on yoga—such as *tratakam* (concentrated gazing) and *nadam* (tuning in to inner sound-vibration) are also taught and given extensive treatment. There are chapters on "Techniques to Magnetize the Body", "Group Relaxation and Group Magnetism", "Postoperative and Post-meditative Suggestion", "Anesthesia Produced by Yoganidra", "Heal Yourself by Your Own Hormones and Tranquillizers", et al.

One might find fault with the book's somewhat excessive load of Hindu terminology, much of which is redundant, and of more interest to students of Indian culture than to practitioners.

This is probably the best book for those professionals and laymen who want to apply yogic techniques in physical and psycho-therapy both for themselves and others.

[Suggested and reviewed by  
Ralph Metzner]

**Lucis Trust Library**

Here's an unusual freebie: a mail library of magical books. The catalog lists 1600 titles from ABC of Jung's Psychology to Zoroastrianism: The Religion of the Good Life. You can borrow two books at a time for a month. Lucis is a nice service that subsists on contributions; it probably is fragile to exploitive use.

Catalog [Suggested by Gerald Thatcher]  
free from:  
The Lucis Trust Library  
866 United Nations Plaza  
Suite 566-567  
New York, N. Y. 10017

**Man's Presumptuous Brain**

Dr. Simeons spent 18 years in India (had brilliant successes with malaria there). Is that why he's written the most useful yoga book to originate in the West? It's not a yoga book, of course, it's an investigation of psychosomatic disease (which will probably kill you and is certainly killing us). Simeons' contention is that our brains, cerebral cortex specifically, have evolved clean out of coordination with the rest of our nature, body especially. It is the arrogant cortex that permits us to burn holes in our stomachs and in each other.

The book would be worth reading just for its central theme, but a whole lot more than just that is going on in Simeons and in the book. Unique document.

[Suggested by Steve Baer]

Psychosomatic ailments account for the bulk of urban man's ill-health and are the most frequent cause of his death. Man shares this kind of affliction with no other living creature.

The reptilian brain is so organized that it must respond to all incoming messages from the senses. On the ground these messages lead to purposeful actions, for instance burrowing for food or safety; but in the trees many of these actions became pointless. A reptile's behaviour is governed entirely by automatic reflexes. Its actions are not subject to reason. It does not have to make a choice between different ways of reacting. All its actions are due to sensory messages putting an ingrained reflex into operation, and over this process the reptile has no control.

A reptile, taking to the trees, carried with it all the ancient reflexes which it had acquired in millions of years on the ground. These reflexes which the change of habitat rendered useless must have been a terrible harassment to an already overworked reptilian brain. In the slow course of evolution these reflexes would have gradually changed into more suitable ones. But so desperate was the situation of the tree-living reptile that it would have become extinct long before normal evolutionary trends could have brought about a better adjustment to the new environment. Some sort of evolutionary shortcut was needed if the species was to survive.

The shortcut was biologically evolved out of just the right mutations occurring at this dramatic moment. It consisted of a mechanism which blocked useless messages from the nose and thus prevented them from reaching those centres of the brain which would have been obliged to react to them. In the olfactory lobes a few cells took over the function of a screening device, a sort of censorship or filter by which incoming olfactory messages were either suppressed or allowed to pass, according to their vital importance. This sorting or classifying of smells relieved the reptilian brain of the exhausting need to react to every message from the nose and thus, in the trees, proved to be an efficient labour-saving device.



**Fundamentals of Yoga**  
Rammurti Mishra  
1959; 256 pp.

\$1.25

from:  
Lancer Books  
1560 Broadway  
New York, N. Y. 10036

or WHOLE EARTH CATALOG



1. Adopt an easy posture.
  2. Relax your entire body.
  3. Feel your heart pumping in the chest.
  4. Hold your breath.
  5. In a moment you will feel that heart rate and vigor of beat are increased.
  6. With every heartbeat, the heart is sending energy to every part of the body. Feel it.
  7. With increased heart rate and beat, energy is changed into electromagnetic pulsation and the entire body is filled with it. Feel it.
  8. The entire is now magnetized, and the spiritual heart and spiritual consciousness are fully manifested in you. Feel them.
  9. The whole body becomes the heart of the universe, and you feel that the entire body is pulsating as a single heart.
  10. Gradually you forget the feelings of the physical body and you identify yourself completely with supreme consciousness.
  11. Now you know that your consciousness is never a product of the body, but is manifested in the body.
  12. Feel that your body is one point of manifestation of consciousness but really you are everywhere. . . . .
- "Now you are in your native land. Now you do not know where your body is. The entire universe is in you and you are in the entire universe. Innumerable suns, stars, and planets are moving in you. Feel it, enjoy your real life." Complete silence.

There are innumerable varieties of *nadam*, but they will be impractical for beginners. The following ten are the most useful and frequent:

1. Cin *nadam*: Like the hum of the honey-intoxicated bees; idling engine vibration; rainfall; whistling sounds; high frequency sound.
2. Cincin *nadam*: Waterfall, roaring of an ocean.
3. Ghanta *nadam*: Sound of a bell ringing.
4. Sankha *nadam*: Sound of a conch shell.
5. Tantri *vina*: Nasal sound, humming sound like that of a wire string instrument.
6. Tala *nadam*: Sound of a small tight drum.
7. Venu *nadam*: Sound of a flute.
8. Mridanga: Sound of a big bass drum.
9. Bheri *nadam*: Echoing sound
10. Megha *nadam*: Roll of distant thunder.

Seven Human Temperaments, The . . . . .	Geoffrey Hodson
Seven Principles of Man, The . . . . .	Annie Besant
Seven Rays, The . . . . .	Ernest Wood
Seven Seventy-Seven . . . . .	Anonymous
Seventy-Fifth Anniversary Book of the Theosophical Society . . . . .	Josephine Ransom
Sex Worship . . . . .	Clifford Howard
Shadow Forms . . . . .	Manly Hall
Shinto, The Unconquered Enemy . . . . .	Robert O. Ballou
Shri Ramakrishna . . . . .	T. L. Vaswani
Signs and Symbols of Primordial Man, The . . . . .	Albert Churchward
Signs and Symbols . . . . .	George Oliver
Simple Method of Raising the Soul to Contemplation, The . . . . .	Francisca Malaval
Simple Study in Theosophy, A . . . . .	Michael J. Witty
Simple Way, The . . . . .	W. Gorn Old
Simplified Scientific Astrology . . . . .	Max Heindel

**Meditation Cushions and Mats**

Traditionally designed softness for your hard edges:



Catalog free  
Zafu \$5.50 Available in 5-6" height, or to order. Fabric is traditional black or brown.  
Zabuton (mat for added height and ease on knees) \$6.50.  
from:  
Alaya Stitchery  
455 14th Street  
San Francisco, CA 94103

One of the most remarkable things about the growth of the cortex was the incredible acceleration of this process. While the earlier phases took tens of millions of years to evolve, the later phases were covered in a few hundred thousand years. It seems to be a general law of evolution that once a trend towards a single successful specialization has become firmly established, the speed with which this specialization develops gets faster and faster and may even develop of its own accord beyond the limits of usefulness. Meanwhile, the rest of the body continues to evolve at a slow and steady pace, so that after a while a stage is reached in which all the other evolutionary trends are left far behind the outstanding specialization.

In modern man this development has already gone so far that there are signs of an evolutionary regression in the body in favour of a still more freakish growth of the brain. Modern man's body no longer reaches its full evolutionary maturity, as it did in Neanderthal Man. Though the modern brain develops further than that of Neanderthal Man, modern man's body remains behind in an earlier embryonic stage. He carries certain embryonic features on into adult life. An example of this has already been mentioned in connection with the distribution of human hair, but there are many other instances. One that interest us here is the relationship between the brain and the rest of the body.

In the light-skinned human races the development of the body is sharply braked in the last stages of pre-natal life, while the growth of the cortex is accelerated. There is some evidence to suggest that the negro's body is better adjusted to his brain. He is physically more mature at birth, and under ideal environmental conditions he averages a larger body. From an evolutionary point of view this makes his brain-body ratio more balanced.

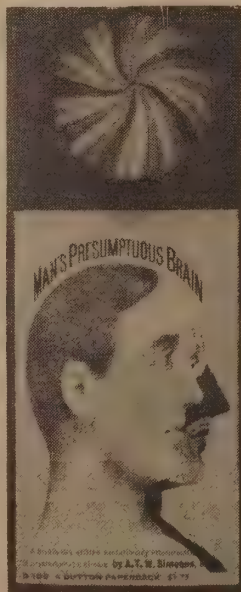

**Man's Presumptuous Brain**  
A. T. W. Simeons, M. D.  
1961; 290 pp.

\$1.75 postpaid

from:  
E. P. Dutton & Co., Inc.  
201 Park Avenue South  
New York, N. Y. 10003  
or WHOLE EARTH CATALOG

The instinct-conflicts which produce an ulcer are usually concerned with sex or family relationships. The modern cortex refuses to admit such conflicts and to expose them to the processes of reasoning. Guilt of this type, therefore, continues to build up behind the censoring screen and forces the diencephalon into the drastic action which causes the ulcer.

This interpretation of the peptic ulcers suggests an obvious psychotherapeutic approach. Censorship at the level of consciousness must be so far relaxed that the conflicting instincts, and the emotion of guilt which they engender, can be ushered into conscious awareness. Thereafter the psychological situation becomes identical with that of a person who has a guilty conscience on account of something he knows he has done, a situation which never produces an ulcer. If such a psychotherapeutic manoeuvre is successfully accomplished, ulcers may heal with surprising rapidity, often in a matter of days, and do not recur unless an entirely new guilt-provoking situation arises.

A tendency to self-destruction seems to be inherent in the over-developed human brain. It is a situation similar to that in which a parasite thrives so exuberantly that it destroys its host, thereby bringing about its own undoing. As the host can survive if the parasite's rapacity is kept within tolerable limits, so man will survive longer if he can release his body and his diencephalon from the cruel cortical grip to which civilization is increasingly subjecting him.

In psychosomatic disease urban man is already paying a heavy price for his civilization, but he now has the means substantially to reduce the price if he will but make full use of them and realize to what extent his cortical presumption, deluding him that he has full control over his animal nature, prevents him from doing so. Western man will eventually go about the solution of his most pressing biological problem through a better understanding of psychosomatic mechanisms and will not adopt the only alternative, which is to give the cortex full rein; for if he did this, all his behaviour would become governed by rigidly conditioned reflexes. His mating and breeding, his drinking and feeding and all his many emotions would then have to conform to a fixed pattern applying to everybody; this would be entirely contrary to the way of life which he has so far followed.

## A Yaqui Way of Knowledge

This book records the experiences of an anthropology student who becomes the apprentice of Don Juan, a Yaqui indian "man of knowledge" who is also a "diablero," a black sorcerer. It is a profoundly disturbing book since it opens up areas and ideas we usually dismiss or deny. Don Juan, over a period of five years, teaches the author a little of his knowledge. He teaches through giving his apprentice various psycho-active plants: peyote, datura, and a mixture of psilocybin mushrooms, genista canariensis, and other plants. Each of these plants has its own way of teaching, its own demands and its own kind of power. For those of us who thought we understood psychedelic effects this book reveals the rudimentary state of our knowledge. For those of us who have dismissed magic as a combination of hypnotism and stage effects we are confronted with powerful and effective magic which seems irrefutable.

Don Juan himself appears as a powerful, indecipherable, wise man whose knowledge is both extensive and alien to our own. He offers to each of us the possibility of dealing with other realities, but he makes it clear that all these ways are dangerous, difficult and once entered, cannot be put aside as simply another experience.

The goal of his teaching is partially expressed as follows:

The particular thing to learn is how to get to the crack between the worlds and how to enter the other world. There is a crack between the two worlds, the world of the diablos and the world of living men. There is a place where these two worlds overlap. The crack is there. It opens and closes like a door in the wind. To get there a man must exercise his will. He must, I should say, develop an indomitable desire for it, a single-minded dedication. But he must do it without the help of any power or any man . . .

Not a book to be read for pleasure, a book which will effect you more than you may wish to be effected.

[Reviewed by James Fadiman]

(Why not read it for pleasure? It's frontier Boswell and Johnson. —SB)

"Don't get me wrong, Don Juan," I protested. "I want to have an ally, but I also want to know everything I can. You yourself have said that knowledge is power."  
"No!" he said emphatically. "Power rests on the kind of knowledge one holds. What is the sense of knowing things that are useless?"

He looked at me for a long time and laughed. He said that learning through conversation was not only a waste, but stupidity, because learning was the most difficult task a man could undertake. He asked me to remember the time I had tried to find my spot, and how I wanted to find it without doing any work because I had expected him to hand out all the information. If he had done so, he said, I would never have learned. But, knowing how difficult it was to find my spot and, above all, knowing that it existed, would give me a unique sense of confidence. He said that while I remained rooted to my "good spot" nothing could cause me bodily harm, because I had the assurance that at that particular spot I was at my very best. I had the power to shove off anything that might be harmful to me. If, however, he had told me where it was, I would never have had the confidence needed to claim it as true knowledge. Thus, knowledge was indeed power.



### The Teachings of Don Juan: A Yaqui Way of Knowledge

Carlos Castaneda  
1968; 276 pp.

\$0.95 postpaid

from:  
Ballantine Books  
Simon and Schuster, Inc.  
630 Fifth Avenue  
New York, NY 10020

or WHOLE EARTH CATALOG

Once a man has vanquished fear, he is free from it for the rest of his life because instead of fear, he has acquired clarity of mind which erases fear. By then a man knows his desires; he knows how to satisfy those desires. He can anticipate the new steps of learning, and a sharp clarity surrounds everything. The man feels that nothing is concealed.  
And thus he has encountered his second enemy: Clarity! That clarity of mind, which is so hard to obtain, dispels fear, but also blinds.

"I say it is useless to waste your life on one path, especially if that path has no heart."

"But how do you know when a path has no heart, Don Juan?"

"Before you embark on it you ask the question: Does this path have a heart? If the answer is no, you will know it, and then you must choose another path."

"But how will I know for sure whether a Path has a heart or not?"

"Anybody would know that. The trouble is nobody asks the question; and when a man finally realizes that he has taken a path without a heart the path is ready to kill him. At that point very few men can stop to deliberate, and leave the path."

"How should I proceed to ask the question properly, Don Juan?"

"Just ask it."

"I mean, is there a proper method, so I would not lie to myself and believe the answer is yes when it really is no?"

"Why would you lie?"

"Perhaps because at the moment the path is pleasant and enjoyable."

"That is nonsense. A path without a heart is never enjoyable. You have to work hard even to take it. On the other hand, a path with heart is easy; it does not make you work at liking it."

You have the vanity to believe you live in two worlds, but that is only your vanity. There is but one single world for us. We are men, and must follow the world of men contentedly.

"But is this business of the dog and me pissing on each other true?"  
"It was not a dog! How many times do I have to tell you that? This is the only way to understand it. It's the only way! It was 'he' who played with you."

"Let's put it another way, Don Juan. What I meant to say is that if I had tied myself to a rock with a heavy chain I would have flown just the same, because my body had nothing to do with my flying." Don looked at me incredulously. "If you tie yourself to a rock," he said, "I'm afraid you will have to fly holding the rock with its heavy chain."

## Altered States of Consciousness

If you're doing anything with meditation, dope, hypnosis, dreams, subjective exploration of any kind, this is a useful book. John Lilly borrowed our review copy and returned it with particular recommendation for these articles:

A Special Inquiry with Aldous Huxley into the Nature and Character of Various States of Consciousness	Milton H. Erickson
Toward the Experimental Control of Dreaming	Charles Tart
A Study of Dreams	Frederik van Eeden
The "High" Dream	Charles Tart
Mutual Hypnosis	Charles Tart
The Effects of Marijuana on Consciousness	Anonymous
Subjective Effects of Nitrous Oxide	William James
Attitude and Behavior Change Through Psychedelic Drug Use	Joseph Downing
Psychedelic Agents in Creative Problem Solving	Harman, McKim, Mogar, Fadiman, Stoloroff
Guide to the Literature on Psychedelic Drugs	Charles Tart
An Electroencephalographic Study on the Zen Meditation	Kasamatsu, Hirai
Operant Control of the EEG Alpha Rhythm and Some of Its Reported Effects on Consciousness	Joe Kamiya

Elsewhere in the CATALOG is a book called Direct Use of the Sun's Energy. Tart's book is moving toward Direct Use of the Mind's Energy.

1. The first three to five hours are usually individual, to try to relax and let go.
2. Spouses' problems; usually we like spouses separate for first group treatments. If both are present, it is better if you start in different areas, but if you both want to be together, okay.
3. Don't be surprised at anything you may see the therapist doing—he knows what he is doing.
4. A person who is having trouble breaking through needs something to resist against—the therapist may hand wrestle, or be on top and have three to six others on top as well. The person then can exert all his strength to break loose.
5. Anytime you are in trouble, don't hesitate to ask for help.
6. As people make break-through you'll hear laughing, crying, screaming. Don't worry about it, or get concerned.
7. Nothing is expected of you, don't expect anything of yourself—most people have a glorious trip.
8. Try to avoid impressing anybody—you'll have a better trip.
9. Around three to four hours after beginning, a stimulant will be brought around to keep your energy level up.
10. Anytime you want to stop the trip, take some niacin, 500 to 1000 mgm at a time. Niacin is good for bad re-entry, will make it easier.
11. During the experience, if you want to come together, touch the other person or ask him. He may shake his head 'no,' or else turn and touch you. Don't have hurt feelings, or guilt if they don't want to be with you, be free to be yourselves. ●

The most coherent and articulate sentence which came was this:  
There are no differences but differences of degree between different degrees of difference and no difference.

The change that then came over Bill was dramatic. He began mumbling typical induction suggestions about relaxing, but over the course of a few minutes his voice became dramatic and forceful. He suggested that Anne see a diamond in her hand and concentrate on it and then almost immediately suggested that it would disappear and her mind would go blank. Then he very forcefully suggested physical relaxation as he counted her into hypnosis: when he reached 20 his whole manner changed and became relaxed and soothing. Anne reported a depth of 22.

Bill then began talking about a 'hallucinatory' journey that he and Anne were on together. His voice was confident, smooth, relaxed, and completely convincing that he was describing actual events that were happening rather than anything 'unreal.' They were standing on a mountain slope, in front of the entrance to a tunnel. They walked hand-in-hand down this tunnel, with the explicit suggestion by Bill that they would be going deeper into hypnosis as they walked deeper into the dark tunnel. It was quiet in the tunnel, all outside noises had vanished, and an ineffable feeling of pleasantness and significance pervaded the tunnel. Anne reported a depth of 35 after a few minutes of this, and Bill continued describing their walk down the tunnel.

The tunnel was absolutely real to Anne and Bill (and to Carol), as real as any experience in life. Although it was dark they could 'see' its walls in a strange way: Anne said it felt as if she had a 'light' coming out from under her eyebrows, and "...it wasn't illuminating anything I was seeing, yet it helped me to know that things were there without seeing them." Both Ss reported feeling the texture of the rock walls, which ranged from soft and slippery at places where it seemed moss-covered to quite hard where the bare rock was exposed.

Anne and Carol were intensely curious as to what lay at the end of the tunnel, the end that Bill would not let them reach. This resulted in an interesting aftermath. About a month after this session, Anne was a subject in a group hypnosis test. As she knew what the induction procedure was, she decided to 'go' back to the tunnel and explore it as soon as she was hypnotized but before the suggestibility test items were administered. She found herself running along the tunnel, hurrying to reach the end before the test items. At the end of the tunnel she found a cave, blazing with brilliant white light, and occupied by an old man of angelic appearance. The room was filled with music from an unseen source. Anne repeatedly asked him what this experience meant: he ignored her at first, and finally told her, very sternly, that he could not answer her question because Bill was not with her. Anne then found herself back at the group hypnosis testing.

I asked the Ss about their perceived bodies during the experience and found that they were curiously disembodied much of the time. They mentioned having heads or faces but no bodies at times, and Anne reported that they walked through each other sometimes. When Bill commanded Anne to give him her hand so he could lead her back, Anne reported that she had to "crawl back into my body, sort of. It was almost as if we were moving around with just heads. When Bill said give him my hand, I had to kind of conjure up a hand."

Anne and Bill read the transcripts over and were both shocked. They had been talking about their experiences to each other for some time, and found they had been discussing details of the experiences they had shared for which there were no verbal stimuli on the tapes, i.e. they felt they must have been communicating telepathically or that they had actually been 'in' the nonworldly locales they had experienced. This was frightening to both Ss, for what had seemed a lovely shared fantasy now threatened to be something real. ●

Wonderingly, but with outward calm, I undertook to arouse Huxley from the trance state by accepting the partial clues given and by saying in essence, "Wherever you are, whatever you are doing, listen closely to what is being said, and slowly, gradually, comfortably begin to act upon it. Feel rested and comfortable, feel a need to establish an increasing contact with my voice, with me, with the situation I represent, a need of returning to matters in hand with me not so long ago, in the not so long ago belonging to me, and leave behind but AVAILABLE UPON REQUEST practically everything of importance, KNOWING BUT NOT KNOWING that it is AVAILABLE UPON REQUEST. And now, let us see, that's right, you are sitting there, wide awake, rested, comfortable, and ready for discussion of what little there is."

As he watched, he became annoyed with me since I was apparently trying to talk to him, and he expressed a wave of impatience and requested that I be silent. He turned back and noted that the infant was growing before his eyes, was creeping, sitting, standing, toddling, walking, playing, talking. In utter fascination he watched this growing child, sensed its subjective experiences of learning, of wanting, of feeling. He followed it in distorted time through a multitude of experiences as it passed from infancy to childhood to school days to early youth to teenage. He watched the child's physical development, sensed its physical and subjective mental experiences, sympathized with it, empathized with it, rejoiced with it, thought and wondered and learned with it. He felt as one with it, as if it were he himself and he continued to watch it until finally he realized that he had watched that infant grow to the maturity of 23 years. He stepped closer to see what the young man was looking at, and suddenly realized that the young man was Aldous Huxley himself, and that this Aldous Huxley was looking at another Aldous Huxley, obviously in his early fifties, just across the vestibule in which they both were standing; and that he aged 52, was looking at himself, Aldous, aged 23. Then Aldous, aged 23 and Aldous aged 52, apparently realized simultaneously that they were looking at each other and the curious questions at once arose in the mind of each of them. For one the question was, "Is that my idea of what I'll be like when I am 52?" and, "Is that really the way I appeared when I was 23?" Each was aware of the question in the other's mind. Each found the question of "Extraordinarily fascinating interest" and each tried to determine which was the "actual reality" and which was the "mere subjective experience outwardly projected in hallucinatory form."

When I have been flying in my dreams for two or three nights, then I know that a lucid dream is at hand. And the lucid dream itself is often initiated and accompanied all the time by the sensation of flying. Sometimes I feel myself floating swiftly through wide spaces; once I flew backwards, and once, dreaming that I was inside a cathedral, I flew upwards, with the immense building and all in it, at great speed.

### Altered States of Consciousness

Charles Tart, ed.  
1969; 675 pp.

\$9.95 postpaid

from:  
John Wiley & Sons, Inc.  
One Wiley Drive  
Somerset, N. J. 08873

Western Distribution Center  
1530 South Redwood Road  
Salt Lake City, Utah 84104

or WHOLE EARTH CATALOG

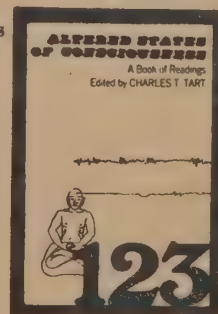

## Plans and the Structure of Behavior

*What I know is that this book and the one to our right (Act of Creation) taught me most of what I know about using my head.*

*The result of a year-long conversation by the authors in California in 1958-59, the book discards Stimulus-Response psychology (which never helped my head, or probably anybody's) and wades into cybernetics instead. The book is cheerful, if academicky. From it the notion of being programmed, and self-programming, emerges as a convenience rather than a threat. That Plans (programs) operate hierarchically rather than single-file is clearly an enormous saving in trouble and trivia. The constant checking of feedback loops (called TOTE units) yields a nice connectedness to the environment. The consideration of contradictory or interrupted Plans gives insight into the uses and misuses of frustration. A handy book, this, of simple concepts for understanding the subtle realm.*

[Suggested by Preston Cutler]

**Plans and the Structure of Behavior**  
George A. Miller, Eugene Galanter, Karl H. Pribram  
1960; 226 pp.

**\$8.50** from:  
Holt, Rinehart and Winston, Inc.  
383 Madison Avenue  
New York, N. Y. 10017

or WHOLE EARTH CATALOG

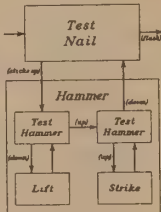

**Plan.** When we speak of a Plan in these pages, however, the term will refer to a hierarchy of instructions, and the capitalization will indicate that this special interpretation is intended. A Plan is any hierarchical process in the organism that can control the order in which a sequence of operations is to be performed.

A Plan is, for an organism, essentially the same as a program for a computer, especially if the program has the sort of hierarchical character described above. . . .

**Execution.** We shall say that a creature is executing a particular Plan when in fact that Plan is controlling the sequence of operations he is carrying out. When an organism executes a Plan he proceeds through it step by step, completing one part and then moving to the next. The execution of a Plan need not result in overt action—especially in man, it seems to be true that there are Plans for collecting or transforming information, as well as Plans for guiding actions. Although it is not actually necessary, we assume on intuitive grounds that only one Plan is executed at a time, although relatively rapid alternation between Plans may be possible. An organism may—probably does—store many Plans other than the ones it happens to be executing at the moment.

**Image.** The Image is all the accumulated, organized knowledge that the organism has about itself and its world. The Image consists of a great deal more than imagery, of course. What we have in mind when we use this term is essentially the same kind of private representation that other cognitive theorists have demanded. It includes everything the organism has learned—his values as well as his facts—organized by whatever concepts, images, or relations he has been able to master. . . .

The central problem of this book is to explore the relation between the Image and the Plan.

If this description of hammering is correct, we should expect the sequence of events to run off in this order: Test nail. (Head sticks up.) Test hammer. (Hammer is down.) Lift hammer. Test hammer. (Hammer is up.) Test hammer. (Hammer is up.) Strike nail. Test hammer. (Hammer is down.) Test nail. (Head sticks up.) Test hammer. And so on, until the test of the nail reveals that its head is flush with the surface of the work, at which point control can be transferred elsewhere. Thus the compound of TOTE [Test-Operate-Test-Exit] units unravels itself simply enough into a coordinated sequence of tests and actions, although the underlying structure that organizes and coordinates the behavior is itself hierarchical, not sequential.

As you brush your teeth you decide that you will answer that pile of letters you have been neglecting. That is enough. You do not need to list the names of the people or to draft an out line of the contents of the letters. You think simply that today there will be time for it after lunch. After lunch, if you remember, you turn to the letters. You take one and read it. You plan your answer. You may need to check on some information, you dictate or type or scribble a reply, you address an envelope, seal the folded letter, find a stamp, drop it in a mailbox. Each of these subactivities runs off as the situation arises—you did not need to enumerate them while you were planning the day. All you need is the name of the activity that you plan for that segment of the day, and from that name you then proceed to elaborate the detailed actions involved in carrying out the plan.

## The Five Ages of Man

*Educational theory presumes that cognitive and intellectual and "social" development is about all that can or need be dealt with in the schools, and the schools act accordingly.*

*Gerald Heard (scarcely mentioning schools) investigates a deeper education, namely emotional human development both in history and in the individual. His effort is to recognize and honor the various stages of people's relation to their own energies, and recognize and honor the requirement of recurrent further growth, and recognize and assist the hard transitions from one stage to the next.*

*His notion spreads out like this:*

Historical stages (5 crises)	Personal stages (5 ordeals)	Initiations (5 mysteries)
Coconscious man	Birth trauma	Rebirth (Earth)
Heroic, self-assertive man	Childhood (becoming paranoia)	Catharsis (Water)
Ascetic, self-accusing man	Adolescence (schizophrenia)	Inspiration (air)
Humanic, self-sufficient man	First maturity (manic depression)	Illumination (fire)
Leptoid, post-individual man	Second maturity (involuntary melancholy)	Transformation (electricity)

*What emerges from all this is pretty radical education. Depending on where a person is hung up, you ritually bury him, or half drown him, or gas him, or burn him, or send electricity through him. Mr. Heard has done much of this to himself and speaks well of the effects. I believe it. Rites of passage are rare these days, and mostly fumbled when they occur. It would be nice to know what's going on and be able to get some help when spontaneous metamorphosis has you spinning.*

*Says Heard, if we tend properly to all the transitions, we will enable old people to be useful and growing, as seers. Gerald Heard is 80.*

[Suggested by Peter Douthit]

## The Five Ages of Man

Gerald Heard from:  
Julian Press  
119 Fifth Avenue  
New York, N. Y. 10003

**\$8.50** postpaid

Briefly, then, this is the thesis of this book: man can train himself, and he has done so with increasing understanding. Although at first this training was implicit in a rite that worked without being consciously comprehended and, next, it was esoteric and a mystery understood only by psychophysical pioneers, today it can become explicitly exoteric, rendered in contemporary terms and applied with scientific exactitude and as a therapeutic education. Such an education can fully develop both an entire person and a complete society. It can produce a constituent able to accept and fulfill his whole personal process and also be the conscious, willing, and developmental unit of a civilization that is creatively run by a common consent and coterminous with a nonviolent mankind.

It is now clear that before historic record, but well illustrated by superb pictures, there was a culture that was preindividualistic and to some extent coconscious because it was under a comprehensive suggestion by imposed interpretation and rule. And even today there are fragmentary societies which (as in Australia and Papua) still seem to preserve much of the same cohesion and precritical amalgamation of psychological value and economic profit. Secondly, there is the Heroic Age, which helped to destroy the preindividual condition and which is itself only protoindividual; only crudely critical of the old order; childish ignorant of its own weakness and faults; boastful, displayful, and un-self-conscious in any sense of objective awareness. It did not understand, it simply reacted. Thirdly, this second stage is succeeded by one of self-questioning and criticism that produces a desire for self-improvement, self-discipline, and finally self-reduction. Then, with struggle, this ascetic, midindividualistic condition passes into the fourth stage when individualism attains totality. At first, man's self-consciousness made him criticize only the tradition-bound group. Then it made him criticize himself. And now, in his complete self-confidence, he no longer sees any need either for boast and shame or for guilt and gratitude. He sees himself as neither condemning nor approving, as being the flawless mirror of the world that is as orderly (and so as repetitively aimless) as he is rational and inventively comprehending.

These four phases have therefore given rise to four distinctive types: (1) the nonpersonal group constituent, (2) the hero, (3) the ascetic and (4) the humanic. And that, until the beginning of this century, seemed to be the culminant end of the story.

For three reasons a specific treatment is required for the present dominant type, the totally self-conscious man, the person of first maturity. (1) Cut off from his own deep, intuitional mind, he must suffer increasingly from a subconscious anxiety. (2) Cut off from interior knowledge of his own body and function rhythms, he must be increasingly attacked by psychosomatic illness. (3) Cut off, psychologically, from the society whose granulation into separate cells he acutely expresses and coercively commands, he must create an international anarchy.

—Planning can be thought of as constructing a list of tests to perform. When we have a clear image of a desired outcome, we can use it to provide the conditions for which we must test, and those tests, when arranged in sequence, provide a crude strategy for a possible Plan. (Perhaps it would be more helpful to say that the conditions for which we must test are an image of the desired outcome.)

We see, therefore, that a person who is caught between conflicting Plans is in a somewhat different situation from the person caught between conflicting motives. He is almost necessarily unaware that his Plans conflict, whereas he may be painfully conscious of his incompatible desires. There is almost certain to be a large penumbra of confusion surrounding the incompatible Plans; the person seems to be deliberately frustrating himself, but cannot discover why. He knows something is wrong, but cannot discover what it is. The two Plans may be isolated from one another in such a way that it never occurs to the person to contrast one with the other.

Human institutions exist primarily for the purpose of executing plans that their members, as individuals, would be unable or unwilling to execute. When the plans that form their *raison d'être* are taken away—finished, frustrated, outlawed, outgrown, completed, whatever—the group may disband. Sometimes they may hold reunions to swim in an ocean of emotion, but then they have become social groups with corresponding changes in the plans they execute. But many planless groups disappear and are never heard from again. In this respect groups are like computers, 90 percent plan and 10 percent image. Individuals, on the other hand are about 75 percent image and 25 Percent Plan.

The means-ends analysis runs something like this: First, see if you know any way to transform the given into the desired solution. If no way is known, then try to reduce the difference between them; find some transformation that reduces the difference, and then apply it. Then try the first step again—see if you know any way to transform the new version of the given into the desired solution. If not, search again for a way to reduce the difference, etc. Each time the difference is reduced, the problem gets a little easier to solve.

A second very general system of heuristic used by Newell, Shaw, and Simon consists in omitting certain details of the problem. This usually simplifies the task and the simplified problem may be solved by some familiar plan. The plan used to solve the simple problem is then used as the strategy for solving the original, complicated problem.

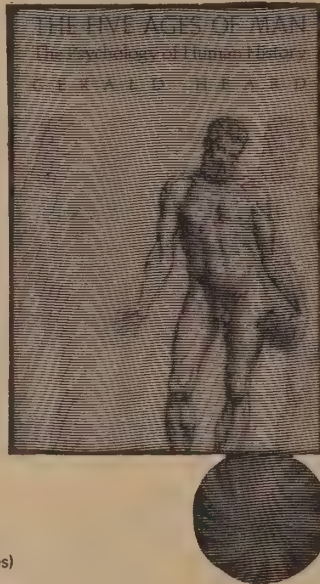

The bigger logs, ablaze but not yet broken up by the fire, were arranged crosswise in the trench, above the bed of flame made by the pieces that had broken down into small brands and bright charcoal. So a kind of cattle-guard or corduroy walk was made, through which grate or grill the flames rose. The priest with the wands, who had sat before the fire while it was being lit and brought to full conflagration, had now moved and sat at one end of the trench with an assistant seated at the other. They stayed sitting like this for a few moments, after which all was ready for the therapy. The first to walk the length of the trench was one of the chief priests. By then a considerable portion of the lay congregation had been brought near and lined up. Old people, the middle-aged, and youngsters—between seventy-five and one hundred persons went along the trench. Dr. Campbell himself went in his turn. He reports, "I deliberately stepped on some nice fat flames, smelled the hair burning on my legs but found the flames were cool. When I put on my socks again I found that my right ankle, which had been swollen and sore from a strain acquired at Ankor Vat some weeks before, had gone down to normal and no longer hurt. The next day I walked some nine or ten miles and the ankle was still OK. The skin of my feet had not been damaged in the least—not even reddened by the flames. . . ."

A meteorologist friend of Jellinek's, caught in a thunderstorm on a Swiss peak, used the method. Having braced himself against the possibility of being struck, he was hit three times by lightning. But although his clothes were torn and his skin broken, because he was prepared he was neither stunned nor did he suffer anything but the surface abrasions.

The emergence of second maturity, the large class of healthy grandparents, can be understood and be availed of only if we see that this fifth phase is inevitable; that it is the essential requirement for the manning of a fifth category of mankind, the fifth age of man as a race and as a person.

Now, with old age and at the upper end, Nature restores freedom of choice and permits, once again, that rightful irresponsibility to enquire and explore regardless of consequences. Being relieved of the armor of authority and the enforcement instruments of command, those in second maturity are once more at liberty to enquire rather than to order, and to question rather than reply.

Second maturity is a return to a regenerated outlook emotionally and intellectually, a resumption of generalized response. Hence, it can be the state in which it would be natural for the capacity of seership to be attained, to re-emerge. And, with that capacity, to regain a generalized affection, good will, and anxiety-free concern and vision into the nature of time that would explicate death by uniting the mind with eternal life.

The actual procedure of the water initiation would, then, involve first an immersion, naked and in a tank of circulating water kept at body temperature, and wherein the body would be irrigated exteriorly and interiorly. The eyes could see, through a glass visor, the water-suffused and wavering light that should probably also have rhythmic light patterns given it by the use of a stroboscope. The ear should be vibrated by sound rhythms of a comparable frequency sent through the water, which is a better sound-carrying medium than air. In this medium and state the postulant should first be floated. But after ten minutes the water in the tank would be made to begin a pulsing, vortex movement. And against this whirlpool he would have to struggle until exhausted. At this point he should achieve a further loss of self; he should emerge into an enlarged state of consciousness.

## The Act of Creation

*Koestler takes his notion of bisociation to be the root of humor, discovery, and art. I take it to be one of the roots of learning, subject to applications of method (on yourself or whomever).*

*Koestler is a scientist of some reputation by now. He's made contributions beyond the work of others that he's generalized from. This is the book that gave him the reputation.*

There are two ways of escaping our more or less automatized routines of thinking and behaving. The first, of course, is the plunge into dreaming or dream-like states, when the codes of rational thinking are suspended. The other way is also an escape—from boredom, stagnation, intellectual predicaments, and emotional frustration—but an escape in the opposite direction; it is signaled by the spontaneous flash of insight which shows a familiar situation or event in a new light, and elicits a new response to it. The bisociative act connects previously unconnected matrices of experience; it makes us 'understand what it is to be awake, to be living on several planes at once' (to quote T.S. Eliot, somewhat out of context).

The first way of escape is a regression to earlier, more primitive levels of ideation, exemplified in the language of the dream; the second an ascent to a new, more complex level of mental evolution. Though seemingly opposed, the two processes will turn out to be intimately related.

When two independent matrices of perception or reasoning interact with each other the result (as I hope to show) is either a collision ending in laughter, or their fusion in a new intellectual synthesis, or their confrontation in an aesthetic experience. The bisociative patterns found in any domain of creative activity are tri-valent: that is to say, the same pair of matrices can produce comic, tragic, or intellectually challenging effects.

The re-structuring of mental organization effected by the new discovery implies that the creative act has a revolutionary or destructive side. The path of history is strewn with its victims: the discarded isms of art, the epicycles and phlogistons of science.

Associative skills, on the other hand, even of the sophisticated kind which require a high degree of concentration, do not display the above features. Their biological equivalents are the activities of the organism while in a state of dynamic equilibrium with the environment—as distinct from the more spectacular manifestations of its regenerative potentials. The skills of reasoning rely on habit, governed by well-established rules of the game; the 'reasonable person'—used as a standard norm in English common law—is level-headed instead of multi-level-headed; adaptive and not destructive; an enlightened conservative, not a revolutionary; willing to learn under proper guidance, but unable to be guided by his dreams.

The main distinguishing features of associative and bisociative thought may now be summed up, somewhat brutally, as follows:

Habit	Originality
Association within the confines of a given matrix	Bisociation of independent matrices
Guidance by pre-conscious or extra-conscious processes	Guidance by sub-conscious processes normally under restraint
Dynamic equilibrium	Activation of regenerative potentials
Rigid to flexible variations on a theme	Super-flexibility (reculer pour mieux sauter)
Repetitiveness	Novelty
Conservative	Destructive-Constructive

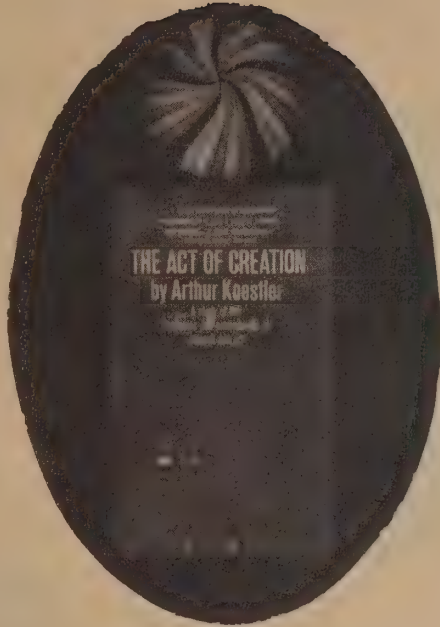

**The Act of Creation**  
Arthur Koestler  
1964; 750 pp.

**\$1.25** postpaid

from:  
Dell Publishing Company, Inc.  
750 Third Avenue  
New York, N.Y. 10017

or **WHOLE EARTH CATALOG**

I have coined the term 'bisociation' in order to make a distinction between the routine skills of thinking on a single 'plane', as it were, and the creative act, which, as I shall try to show, always operates on

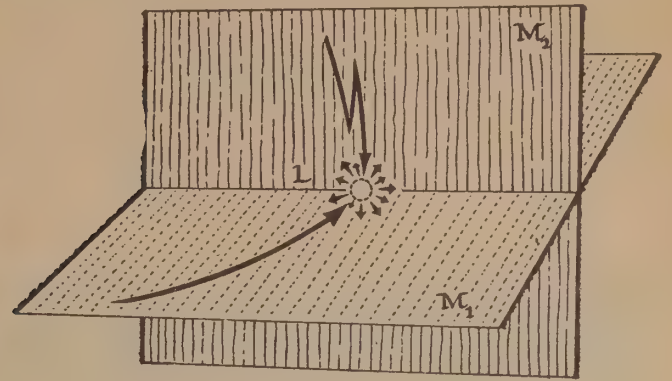

more than one plane. The former may be called single-minded, the latter a double-minded, transitory state of unstable equilibrium where the balance of both emotion and thought is disturbed.

In the popular imagination men of science appear as sober ice-cold logicians, electronic brains mounted on dry sticks. But if one were shown an anthology of typical extracts from their letters and autobiographies with no names mentioned, and then asked to guess their profession, the likeliest answer would be: a bunch of poets or musicians of a rather romantically naive kind.

Modern man lives isolated in his artificial environment, not because the artificial is evil as such, but because of his lack of comprehension of the forces which make it work—of the principles which relate his gadgets to the forces of nature, to the universal order. It is not central heating which makes his existence "unnatural," but his refusal to take an interest in the principles behind it. By being entirely dependent on science, yet closing his mind to it, he leads the life of an urban barbarian.

I must mention one specific factor which is largely responsible for turning science into a bore, and providing the humanist with an excuse for turning his back on it. It is the academic cant, of relatively recent origin, that a self-respecting scientist must be a bore, that the more dehydrated the style of his writing, and the more technical the jargon he uses, the more respect he will command. I repeat, this is a recent fashion, less than a century old, but its effect is devastating. The pre-Socratics frequently wrote their treatises in verse; the ancient Peruvian language had a single word—hamavec—for both poet and inventor. Galileo's Dialogues and polemical writings were literary masterpieces which had a lasting influence on the development of Italian didactic prose; Kepler's New Astronomy is a baroque tale of suspense; Vesalius' Anatomy was illustrated by a pupil of Titian.

## The I Ching

*The I Ching, the Book of Changes, is a brilliant problem-solving device. A problem (or ignorance) generally consists of being caught in local cyclic thinking. To consult the oracle, the wisdom of chance (or synchronicity, no matter), is to step out of the cycle of no-change and address a specific story on the nature of change. You now have an alternative set of solutions that owe nothing but proximity to your problem. You make the associations, you find the way out. It's prayer.*

*I can't think of a more important and useful book than this one. It's famously ancient, poetic, deep, esoteric, simple, involving. It has been the most influential book on American art and artists in the last 15 years.*

*Most people know about it. We've included it here to point at the new smaller (unabridged) cheaper Princeton University Press version of the classic Wilhelm-Baynes Bollingen edition. The oracle method is still on page 721.*

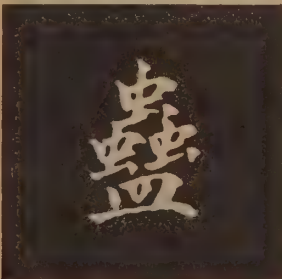

18. Ku/ Work on What has Been Spoiled  
[Decay]

above	KEN	Keeping Still, Mountain
below	SUN	The Gentle, Wind

The Chinese character ku represents a bowl in whose contents worms are breeding. This means decay. It has come about because the gentle indifference of the lower trigram has come together with the rigid inertia of the upper, and the result is stagnation. Since this implies guilt, the conditions embody a demand for removal of the cause. Hence the meaning of the hexagram is not simply "what has been spoiled" but "work on what has been spoiled."

### THE JUDGMENT

WORK ON WHAT HAS BEEN SPOILED  
Has supreme success.  
It furthers one to cross the great water.  
Before the starting point, three days.  
After the starting point, three days.

What has been spoiled through man's fault can be made good again through man's work. It is not immutable fate, as in the time of STANDSTILL, that has caused the state of corruption, but rather the abuse of human freedom. Work toward improving conditions promises well, because it accords with the possibilities of the time. We must not recoil from work and danger—symbolized by crossing of the great water—but must take hold energetically. Success depends, however, on proper deliberation. This is expressed by the lines, "Before the starting point, three days. After the starting point, three days." We must first know the causes of corruption before we can do away with them; hence it is necessary to be cautious during the time before the start. Then we must see to it that the new way is safely entered upon, so that a relapse may be avoided; therefore we must pay attention to the time after the start. Decisiveness and energy must take the place of the inertia and indifference that have led to decay, in order that the ending may be followed by a new beginning.

### THE IMAGE

The wind blows low on the mountain:  
The image of DECAY.  
Thus the superior man stirs up the people  
And strengthens their spirit.

When the wind blows low on the mountain, it is thrown back and spoils the vegetation. This contains a challenge to improvement. It is the same with debasing attitudes and fashions; they corrupt human society. To do away with this corruption; the superior man must regenerate society. His methods likewise must be derived from the two trigrams, but in such a way that their effects unfold in orderly sequence. The superior man must first remove stagnation by stirring up public opinion, as the wind stirs everything, and must then strengthen and tranquillize the character of the people, as the mountain gives tranquillity and nourishment to all that grows in its vicinity.

Nine in the third place means:  
Setting right what has been spoiled by the father.  
There will be a little remorse. No great blame.

This describes a man who proceeds a little too energetically in righting the mistakes of the past. Now and then, as a result, minor discords and annoyances will surely develop. But too much energy is better than too little. Therefore, although he may at times have some slight cause for regret, he remains free of any serious blame.



**The I Ching**  
Translated by Richard Wilhelm, Cary F. Baynes  
? B.C.; 740 pp.

**\$5.25** postpaid

from:  
Shambala Publications, Inc.  
P. O. Box 4336, Sather Gate  
Berkeley, Calif. 94704

or

**\$6.00** postpaid

from:  
Princeton University Press  
Princeton, New Jersey 08540

or **WHOLE EARTH CATALOG**

Bob Dylan's first major interview in three years is in the new issue of Rolling Stone Magazine. In the same edition of Rolling Stone, the first complete discography of the unreleased Dylan tapes and records. The interview with Bob Dylan, based on a four hour run with Rolling Stone Editor Jana Wenner, is complete and unedited.

# DYLAN

AMAZEMENT GUARANTEED!

Send \$1.00 to "Dylan Interview," 746 Brannan Street, San Francisco, Calif. 94103. We'll send you both the special Dylan Interview issue and a little something else.



**KAIBAB NAVAJO BOOT**  
for men NB - 2 20.00

**KAIBAB NAVAJO SQUAW BOOT**  
for women SB - 1 19.00

THE ORIGINAL — TRADITIONAL TRIBAL FOOTWEAR OF THE NAVAJO INDIANS — THIS BOOT IS STILL WORN TODAY ON THE RESERVATION IN ARIZONA AND NEW MEXICO.

SOLES OF BLEACHED WHITE RAWHIDE — UPPERS OF BUCKSKIN IN RUST; NATURAL TAN.

Send outline of foot (state thereon your conventional shoe size) for perfect fit. Take outline standing, weight evenly distributed on both feet.

Do not wear on wet, slick surfaces

**KAIBAB BUCKSKIN INC.**  
271 North Stone • Box 5156 • Tucson, Arizona

# THE I CHING

*The Richard Wilhelm Translation rendered into English by Cary F. Baynes*

Foreword by C. G. Jung

Preface to the Third Edition by Hellmut Wilhelm

OR BOOK OF CHANGES

**WILHELM/BAYNES**

BOLLINGEN SERIES XIX  
PRINCETON UNIVERSITY PRESS



Available for \$5.25  
—a 12½% saving—  
from:  
Shambala Publications, Inc.  
P. O. Box 4336, Sather Gate  
Berkeley, California  
94704



董作賓題

衛禮賢譯解



## DON'T GO TO THE WOODS UNTIL YOU SEE OUR CATALOG

We have been outfitting expeditions for over a decade and our quality light-weight gear can make your trip more enjoyable . . . and, after all, that is what it's all about.

catalog on request

the ski hut 1615 university ave., berkeley, calif. 94703

Shambala Publications, Inc.  
P. O. Box 4336, Sather Gate  
Berkeley, CA 94704

Please fill my order for \_\_\_\_\_ copies of *The I Ching*.  
Enclosed please find check or money order for \$ \_\_\_\_\_

name \_\_\_\_\_  
address \_\_\_\_\_

ZIP \_\_\_\_\_

(cut along dotted line)

# CATALOG Costs

In the interests of keeping our operation comfortably transparent, here are some of the highlights from the CATALOG numbers game for 1969:

Fall '68 CATALOG: 1,000, then another 1,000 printed and sold.  
 Spring '69 CATALOG: 10,000, then another 20,000 printed and sold.  
 Fall '69 CATALOG: 60,000 printed Nov. 28.  
 At present we have something around 4,000 subscribers.

It took about \$25,000 in initial loans to start the CATALOG in the fall and winter of 1968. These have yet to be paid off due to the costs of keeping ahead of mushrooming demand.

Revenue for the WHOLE EARTH TRUCK STORE AND CATALOG has gone from \$2,000/month to \$28,000/month between January and October. Expenses have kept pace. 10% of what comes in goes to Portola Institute. CATALOG and Truck Store staff get \$2-5/hour. Two major quasi-essential costs were \$3,000 for a population event called LIFERAFT EARTH and \$4,000 for a Stat-King camera.

This CATALOG is costing something over \$33,000 to produce 60,000 copies (the figure does not include research), which puts the unit cost at about 55¢ per CATALOG.

Except for a few exchange ads at the beginning (negligible effect), Whole Earth has not advertised. Growth has been through word of mouth and unsolicited reviews and articles. It sure feels good that way.

In the last Supplement we announced our intention to cease publication of the CATALOG in the Spring of 1971. That still seems like a good idea to us.

Total Cost—  
 Fall 1969 CATALOG  
 \$33,000.

60,000 copies  
 Nov. 1969

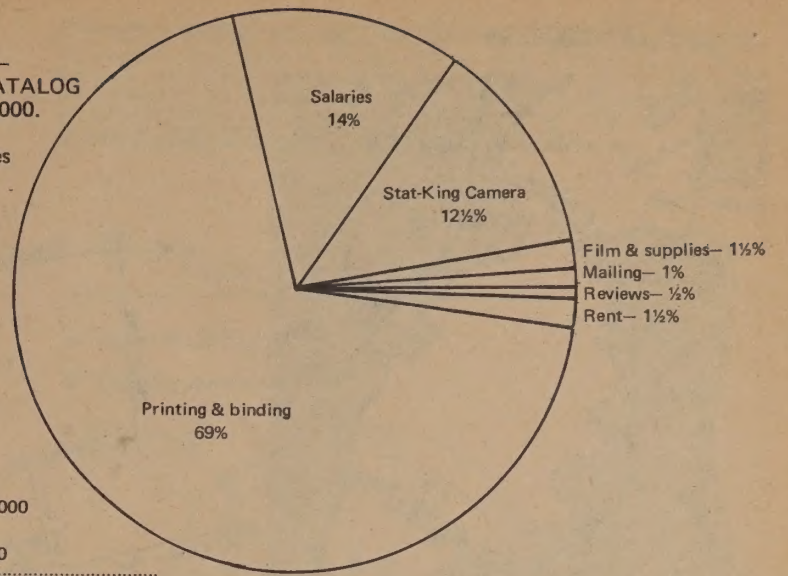

Cash flow, 1969

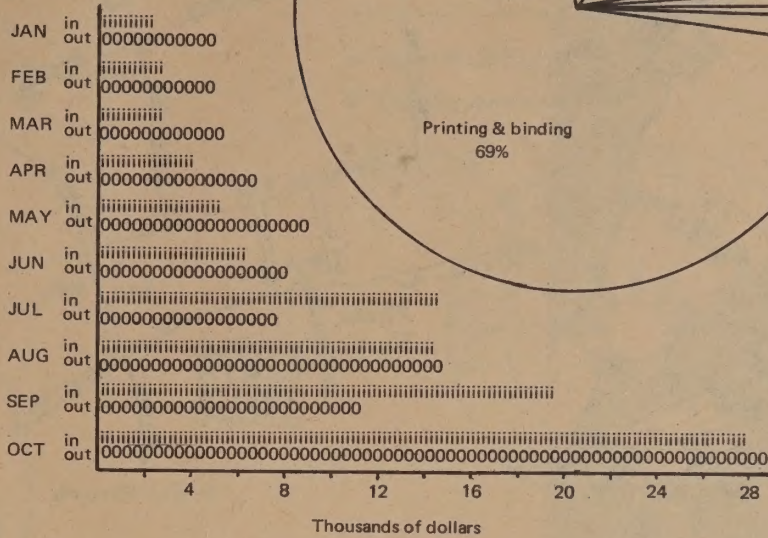

Arthur and Julia Brand

Obviously the CATALOG couldn't have happened without money and organization in front. The funds were there by grace of my parents and grandparents. The organization was there in the person of Richard Raymond, head of Portola Institute, who had immediate encouragement and basic facilities on hand when the idea first hit.

It's as Dick Alpert used to say: It's love money that underwrites this sort of venture every time. Which suggests that if foundations and governments want to do the job they say they do, they should retain the services of better lovers.



Richard Raymond

## Suggestions for the WHOLE EARTH CATALOG

An item is listed in the CATALOG if it is deemed:

- 1) Useful as a tool,
- 2) Relevant to independent education,
- 3) High quality or low cost,
- 4) Easily available by mail.

Please fill in as much information as you possibly can; it helps a lot.

My name \_\_\_\_\_

Address \_\_\_\_\_

\_\_\_\_\_

Date \_\_\_\_\_

Phone \_\_\_\_\_

I SUGGEST:

Title of book or name of item: \_\_\_\_\_

\_\_\_\_\_

Author \_\_\_\_\_

Price \_\_\_\_\_

Publisher or Supplier \_\_\_\_\_

Address \_\_\_\_\_

If an item suggested is intended to replace an item already in the CATALOG, please fill in the item to be replaced:

I would like to write a review. \_\_\_\_\_

Attached is a review of this item.

I would recommend \_\_\_\_\_ (name, address, phone)

to review this item.

Additional information: \_\_\_\_\_

\_\_\_\_\_

\_\_\_\_\_

\_\_\_\_\_

\_\_\_\_\_

\_\_\_\_\_

\_\_\_\_\_

\_\_\_\_\_

\_\_\_\_\_

\_\_\_\_\_

Whole Earth Truck Store

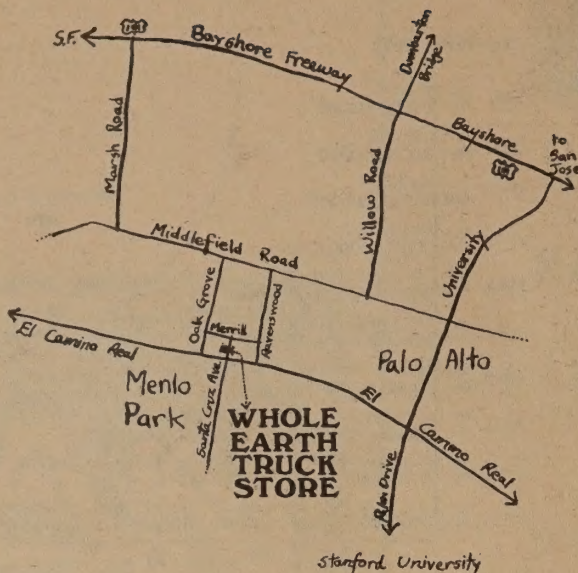
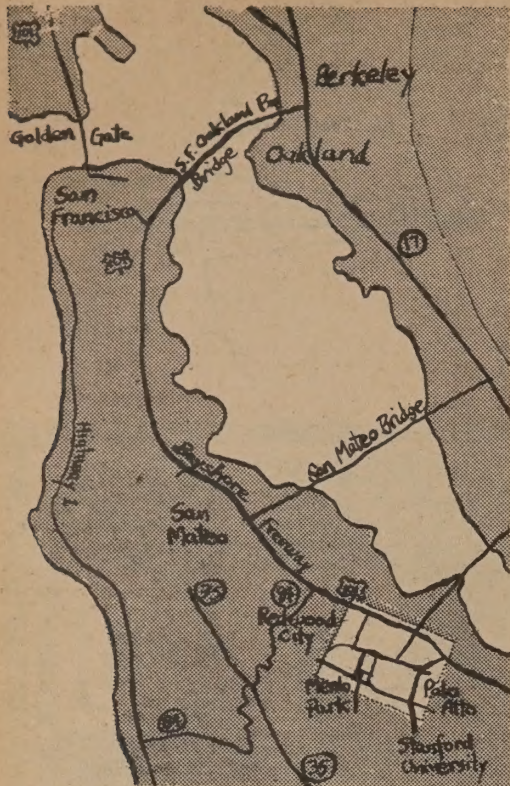

A major research source of ours is the Menlo Park Whole Earth Truck Store, which stocks most of the items in the CATALOG. We see who's buying what. We hear complaints and suggestions. We try out items that might be in the next CATALOG. We have a place where friends can come and see what's happening.

Hours: Monday-Friday, 9 am - 6 pm  
Saturday, 10 am - 3 pm

558 Santa Cruz, Menlo Park, CA. 94025  
Phone: 415 323-0313

Distributors

The WHOLE EARTH CATALOG is a publication of Portola Institute, published twice a year; the Difficult But Possible Supplement to the CATALOG is published four times annually. CATALOGS retail for \$4.00, Supplements for \$1.00 each. The following are our distributors - inquire to each for terms:

BOOK PEOPLE  
2010 SEVENTH STREET  
BERKELEY, CALIFORNIA 94710

ALPHA BOOK DISTRIBUTORS  
59 FOURTH AVENUE  
NEW YORK, NEW YORK 10003

CHRISTOPHER BEATY  
2439 1/2 CORINTH AVENUE  
LOS ANGELES, CALIFORNIA 90064

Shambala Booksellers  
2482 Telegraph Avenue  
Berkeley, California 94704

Chittam, Inc.  
690 Massachusetts Avenue  
Boston, Massachusetts 02118

Koobdooga Books  
P. O. Box 1701  
Eugene, Oregon 07401

Rocky Mountain Good Karma General Store  
644 Spruce  
Boulder, Colorado 80302

Robin's Book Store  
6 North 13th Street  
Philadelphia, Pennsylvania 19107

Harlan T. Crider  
135 South 18th Street  
Philadelphia, Pennsylvania 19103

Whole Earth Cooperative  
845 East Johnson  
Madison, Wisconsin 53703

Booksmith Distributing Corporation  
71 Amory Street  
Roslbury, Massachusetts 02119

Jeffrey Noebels  
C/O Reed College  
Portland, Oregon 97202

Moe's Books  
2484 Telegraph Avenue  
Berkeley, California 94704

Bob Gibbs-Vocations for Social Change  
Box 13  
Canyon, California 94516

Finittin Associates  
351 Massachusetts Avenue  
Cambridge, Massachusetts 02139

Eric Kress & Hoyt Corbett  
Box 1390  
Amherst, Massachusetts 01002

Terry Van Brunt  
P. O. Box 313  
Panacea, Florida 32346

Whitney Museum of American Art  
945 Madison Avenue at 75th Street  
New York, New York 10021

Harvard Cooperative Society  
1400 Massachusetts Avenue  
Cambridge, Massachusetts 02138

College Bookstore  
College Center Building  
Colorado State College  
Greeley, Colorado 80631

We are in the market for more distributors in various parts of the country. Our terms to distributors are: 40% on orders of 25 or more, 50% on orders of 50 or more, plus shipping costs, half-payment in advance, net 30 days.

We also sell one-year subscriptions to the CATALOG for \$8.00 a year, which includes Fall and Spring issues of the CATALOG, and the four Supplements. As this is a discounted price, no further discount is offered on quantity orders for subscriptions.

Hal Hershey  
Whole Earth Truck Store

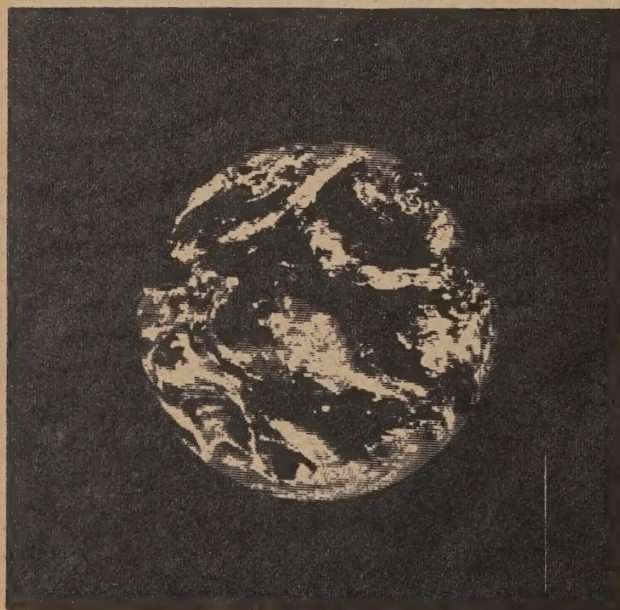

Subscription Form

Send to: WHOLE EARTH CATALOG  
Portola Institute  
558 Santa Cruz  
Menlo Park, California 94025

\$ \_\_\_\_\_ Amount enclosed.

\$ 4  One issue of CATALOG 19\_\_ Fall 19\_\_ Spring (The Fall 1968 CATALOG is no longer available.)

\$15  Five copies of current CATALOG

\$ 8  One year subscription: two CATALOGs and four Supplements

U.S. and Canada starting 19\_\_ Fall CATALOG 19\_\_ Jan. Supplement 19\_\_ March Supplement  
\$9 surface elsewhere;  
\$14.60 air elsewhere.

19\_\_ Spring CATALOG 19\_\_ July Supplement 19\_\_ Sept. Supplement

\$ 25  One year Retaining Subscription

\$100  One year Sustaining Subscription



# PORTOLA INSTITUTE

INC.  
1115 MERRILL ST.  
MENLO PARK,  
CALIFORNIA  
323-5155

The Whole Earth Catalog is one division  
of PORTOLA INSTITUTE, INC.

Other present activities of the Institute include:

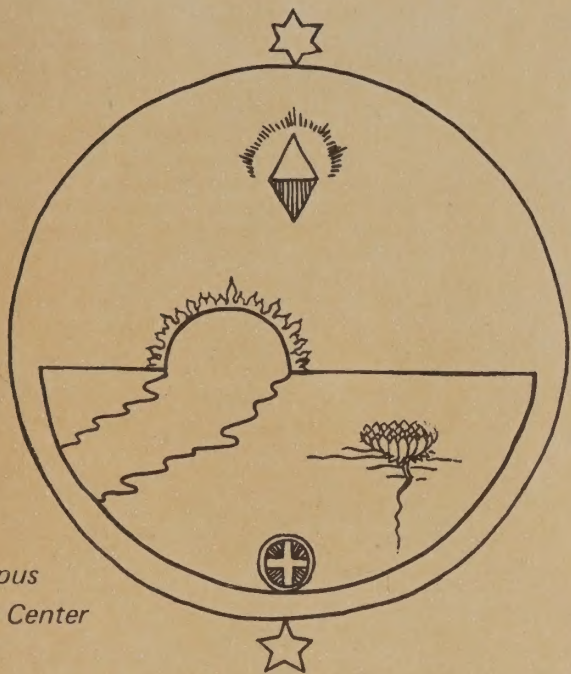

Scripps Off Campus  
Project Center

The cover is a paste-job, using color photographs of Earth and Moon from recent NASA Apollo missions. The view is approximately correct for a viewer co-planar with the Moon's orbit, 400,000 miles out from Earth. Due to perspective on the Moon's orbit, the Moon appears closer to the Earth than its actual distance of 30 Earth diameters. When you look through a filter dense enough to distinguish surface features on the planet, the stars are invisible.

### Music Studies Program

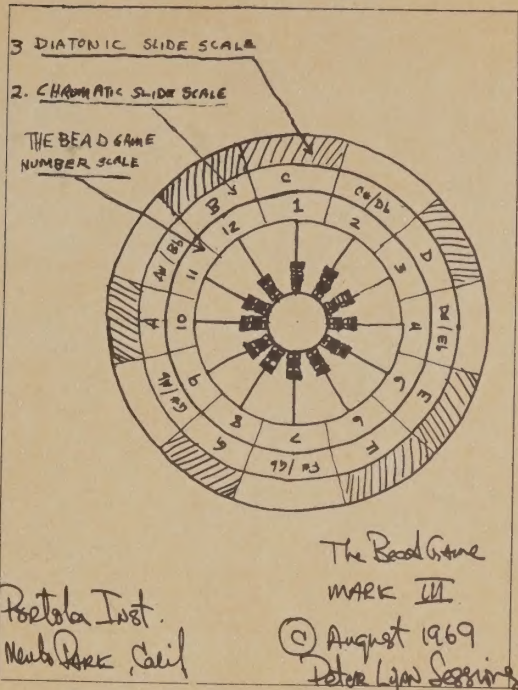

Portola Inst.  
Menlo Park, Calif

The Bead Game: a composition system

### Ortega Park Teachers Laboratory

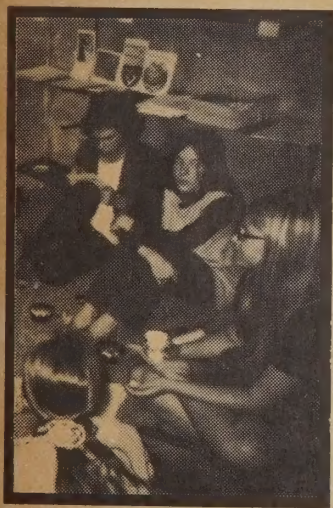

High school underground  
newspaper meeting at  
Scripps.

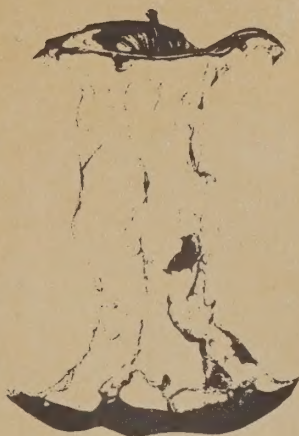

THE WILDCAT SCHOOL



Two posters for recent meetings at Ortega Park.



PORTOLA INSTITUTE was established in 1966 as a nonprofit corporation to encourage, organize, and conduct innovative educational projects. The Institute relies for support on private foundations and public agencies, to whom specific project proposals are submitted.

Because Portola Institute is a private organization with no need to produce profits or guarantee "success", it can experiment with new and unusual educational projects that would be difficult to administer within more structured organizations. For this reason the staff and facilities of the Institute are deliberately kept small and flexible.

Within its framework a wide variety of projects dealing with innovative education can be created as people with ideas are able to interest people with funds. New projects are always being considered, both within the existing divisions and programs, and within as yet unexplored realms of the learning experience.

Portola Institute, Inc.  
1115 Merrill Street  
Menlo Park, CA  
94025

More information on Portola Institute, please.  
Especially \_\_\_\_\_

\_\_\_\_\_  
\_\_\_\_\_  
\_\_\_\_\_

zip

# FURTHER



*closer*

