

decoding the hive



CHEOPS
SPOKE

GLOBAL COLD FUSION
ENERGY TEMPLE NETWORK

Pt. 2

HUMAN HANDBOOK VOL 6

CHEOPS
SPOKE
Pt. 2

DECODING THE HIVE

VOL. 6

HUMAN HANDBOOK SERIES
Cheops SPOKE Pt 2

By: mission guide
inventor, writer, empirical physicist

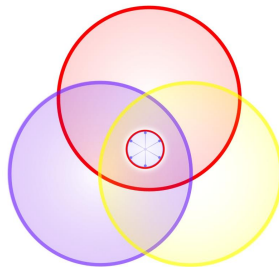

Illustrations original and sourced from public domain under
Fair Use laws for educational purposes

2nd Edition - Copyright 2019 - all rights reserved

1 2 19 19

Forward

[-decodingthehive.info-](http://decodingthehive.info)

Forward

The information shared in this human handbook series is not for everyone, and certainly not for the faint of heart. Life -a material concept- is a journey that each one takes as guided by their higher self. It is not to be mimicked or patterned after someone else's version of what is perfection. Perfection is eternally illusive and eternally the goal within manifestation. **All things** lead us to this ultimate destiny that every fractal of god seeks:

Balance within every single moment.

It is a perspective. Something relative to you and who you have chosen to be. This minute. This day. This life. Some may choose to play the protagonist this time, because last time they were the antagonist and it left a bad taste in their mouth. But you would have no idea whether or not you simply do not resonate with playing the role of the villain until you have played the role of the villain. And neither will your best friend, or your mom or dad. In the end, whether you set out to be the good guy or the bad guy, you will wind up playing both roles during your current life whether you planned to or not. That's because life is a barter every single day and with every single choice. You really would have liked to have: (fill in the blank here), but... **But** since the perfect option wasn't available this time, you choose red apples instead of green. Which leads to the next barter.

Reader Notes

Ebb and flow.

And so goes the many epics that will play out in your journey, encapsulated within that one summer or that one life where you became a sociology professor instead of an architect. You may dislike everyone around you who “isn’t into” what you are into at this one time in your life, but at some point over your incredibly vast journey, you surrounded yourself with only architects for a time, or drug dealers or airline pilots until you had your fill and then moved on to psychology or a thousand -million- other fields of interest.

Within each compartment of time, you will always find something to learn and grow from, regardless if that is your first choice in filling that space in your life or not. Just like you learned important principles about philosophy while you were building a shed or planting a garden; things that you would never expect to learn all alone in your backyard.

Balance is where you are able to be exactly who you are in any situation, whether you are repairing a fence, driving a tow truck or designing a skyscraper. It is all things at all times which translates into contentment regardless of where you are or what you’re doing. Do not make the mistake that just because you had an opinion that you were actually living that moment. Unless your actions (initiative, response or inspiration) comes from inside of yourself

Reader Notes

alone, and not from *what would dad do*, or *what would someone else do*, or *what do others around me expect me to do*, then that was simply put, not an authentic moment of your life, because *only from within* comes authenticity and only from authenticity comes balance.

And the word authentic now comes front and center to your life; where you understand that every fractal of god came into being for one purpose; to be their authentic self. By allowing someone else to influence your initiatives or responses, you are now parroting someone else's authorship.

Daddy isn't going to be there every minute of your life. Neither will mom or sis or bbf. But you will.

You will never find you unless you choose to author that unique being into existence.

Now you have found yourself facing the ultimate challenge: to learn things that will absolutely make you uncomfortable, and test your will to learn more, reach higher and ask from your mind to process what the everyday person will never have the courage to face. The real truth. But in doing so, you know that you will become a better painter, architect, personal assistant, plumber, philosopher and every single thing that you will be before your journey ends.

Reader Notes

By following the beat of your own drum that only you can hear, you are listening to your higher-self offering you guidance on your journey to discover your one signature within the billions of parrots and mimes that make up your world. In that quest, you suddenly become the real you that you have been looking for all along; the one unique expression of life that is the very best version of your mother's son or your father's daughter that could possibly be.

You are not perfect, because there is **no such thing**. When you get mad, that is just you expressing to the world around you that you have not yet reached the point where you are ready to end your quest to “perfect” the forge you wish to leave upon creation. With each damnitsonofabitch, you are allowing another moment to pass where your higher self was telling you *here is that apple of gold you have been asking for, don't miss it*. Do not confuse this lesson as just another bad day where everything went wrong, because it isn't that. This is you learning how to be balanced even as the raft careened into the wrong channel down the rapids. That is just a new journey on your way to you.

You may not be driven to seek your signature through fortune or fame. You may not be driven by merely wanting bigger, better, faster for you and yours. But regardless of what drives you, the one thing that no one who ever lived wanted to leave behind them as their stamp on the world

Reader Notes

once they finally said goodbye was; “**Here Lies Johnny. He Accomplished Nothing.**”

Balance doesn't have to be big and bold, but it *is* self-aware and self-secure. It needs no one to complete itself but you and you alone. Only then will you ever be the perfect friend. Wife. Mother. Dad or brother. The one that always lights up a room because you are not there to place your shortcomings onto anyone else at the party. Your smile comes from knowing that this will be your moment to learn something you didn't know before. And it might be in the form of learning patience mending from a broken leg, or surprising yourself that you really could build that bridge all alone. It might be something as simple as feeling good about yourself just because you helped an ant get up that hill he wasn't going to make all on his own. When you can do that, you know that you are nearing your elusive goal of harmonizing with all things.

These are the moments where you become the *higher* version of the son or daughter mom and dad never thought they would ever meet. The moment where you begin to truly shine because you were willing to do what no one around you was willing to do: to become someone who isn't afraid to learn that nothing up until this time you have ever learned had been the truth, and you were willing to learn that lesson so that your next moment will be better than your last.

Reader Notes

“Tomorrow” is not *the end of your journey*.

It is merely the next step you will take in a never-ending series of steps that define exactly who you really are. So do not make the mistake of thinking that “tomorrow everything will be absolutely perfect” if you *just do this*. Or you summon the will to *do that* in preparation. But it *can be* better. And better is the one constant that balance seeks, regardless, because **this** moment is forever the **last** moment in that **tomorrow doesn’t really exist**. You are “only as good as your last hit” as they say, so make certain this one was your final stamp - your message you leave behind for all to see - because it will be your epitaph should this be your final farewell.

If there has been one thing I have learned from living with council members of a faraway and advanced “fraternity” as they refer to themselves, over the last year, it has been this; to face each second with the same grace and verve as you would on your way to the most elegant affair, undaunted by what may lie ahead. Because the rain cloud overhead may just bring the most dazzling rainbow you will ever see. And that will be the best moment. Not tomorrow, not next year, but right now, this moment.

The easy path to get there is rarely, if ever, the high road. The one well-worn is the one taken by those who merely follow. Leaders aren’t born following, they are born questioning. The wise take the one not just less traveled,

but the one that simply doesn't exist until they bring it into existence.

Swords never sharpen by eviscerating strawberries. They sharpen from moving between rocks and hard places.

You are about to test the steel of your sword now, and face the challenge of learning the language of tomorrow where you will no longer be dwelling in caves and scavenging food and fire. The long cycle of your evolution for this phase of your journey is now over, only if you are truly ready for the next level. Those around you are choosing their own authentic paths, so do not be fearful or worried for them if they are not right by your side during this transition, because they will be exactly where they are supposed to be in their never-ending quest to balance, just like you are.

And how does this answer a single question you have about the pyramids? That should be obvious. You have chosen to enter a field beyond quicksand just by posing the question in your mind that the mountains made out of stone from the ancient past could really have been more than just oversized tombs for oversized egos. Where the answers you now learn will almost assuredly put you even further out of favor with your peers than you already were. Yet you came anyway.

Reader Notes

There are few who will actually break through the barrier between what they have been led to believe all their lives about energy, and learn the language of Interdimensional Scalar Vibrational Mechanics that lies within these pages. The mountains of stone that lie before you on your journey are about to teach you something no one else has bothered to mention until now, and it is up to you to dig down and find that untapped vault inside of you that was written into the very codes of your DNA long before you arrived at this divide to conquer them. It is called your cellular language imprint held in each of your cells where this lexicon truly lies and is merely up to you to remember it now.

You have been handed an artificial reality, so the ground you stand on is not actually real in the sense you think it is. As long as that is the case, one will never find balance.

This is your summit to scale now, as the rope is already right there in your hands. Up there you will find yourself one step closer to balance just by finally learning the truth about how energy really works within a holographic reality created entirely by the sparks produced by thought alone.

-mission guide

Reader Notes

On decodingthehive.info website you will find various companion articles appearing and disappearing as council wishes. You are required to visit this site often and to push yourself to recognize the applicability of the esoteric to the mundane of the everyday.

This report will occasionally be quoting some text from Wikipedia, which is a known Kybal disinformation platform. The only time it is quoted here is when the information has been independently researched from other reliable sources first to determine these to be the most accurate details available in condensed form for the reader's benefit. Do not confuse these selections as a blanket endorsement of that or any other platform. Always cross verify any details you find there or anywhere else.

Wikipedia has many facts relatively correct as far as current scholars agree to be accurate on otherwise random subjects to the researcher, backed up by laboratory results and multiple sources from across the spectrum. In those cases when I already know the report to be accurate within the scope of what is accessible, I will share that information with you as a starting point for your own frame of reference. Much of the data contained therein, if not most, is not "the whole story", since we already know that the most important facts have been deliberately withheld for various reasons that have to do with greed and

Reader Notes

domination. This report is a synopsis only. It is the responsibility of the reader to verify all facts across all available sources for its greatest accuracy.

All subject matter included in this disclosure has been researched extensively and in some cases continually for years before these truths could be spoken. The accuracy of the statements made herein are within the limitations of the feeble power of the human mind to parse. If you find any details outlined that are inaccurate or misstated, please contact me so they may be corrected. This is an evolving body of work. I do not claim to possess all the facts, nor understand all sides to every story. I do claim that the technology presented herein has been vetted for accuracy to the very best of my ability to be factual in order to minimize your journey to the real truths that have been obfuscated for so long.

This disclosure is written under a pseudonym in the event something should end my ability to continue. It will not be the name of the writer, but the voice itself coming through that you will want to continue to seek over the course of your journey for further instruction and clarity. I did not coin the phrase to not follow a man, but follow the message. Faces and names mean nothing; actions do. We have already had many of our team members fall in the course of this mission which could happen again.

Reader Notes

If this voice suddenly goes silent, you will seek these same words as offered by the next soldier in line who will just tell you straight what it is you are up against, and will not couch that in soft fluffy terms to pander to your sensitive feelings. There is no time left for games, as this ascension window is already coming to a close.

Like J. K. Rowling, Mark Twain or Agatha Christie, I write under a pen name that has had to change more than once in order to continue to offer what I am tasked to share with you. I am not here to kid anyone, but merely wish to remain alive so I can continue serving my mission. Anyone who thinks it is easy to inform people they have been misled, just try it sometime for yourself to see the unequalled backlash that comes from even the closest ones around you. If you need to address me, then just call me mission guide for now.

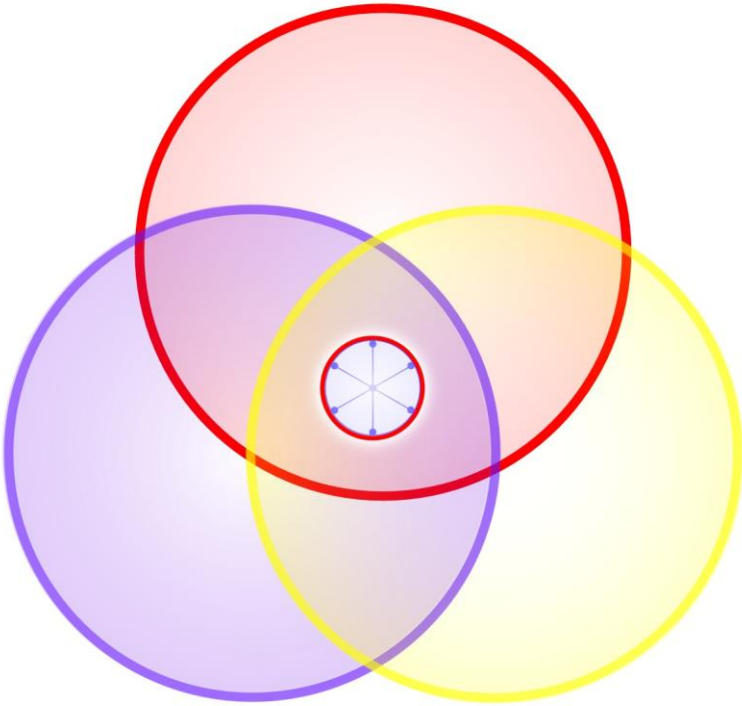

Table of Contents

Cheops SPOKE Pt 2

<i>FORWARD</i>	V
<i>READER NOTES</i>	XIII
TABLE OF CONTENTS CHEOPS SPOKE Pt 2	1
CHAPTER 12 GREBENNIKOV LEVITATION	
REBUILD AND ASCENSION.....	14
GREBENNIKOV LEVITATION CONT.	20
MONOATOMIC NOBLE METALS.....	27
LEVITATING BISMUTH PREDATOR DRONES	40
CHAPTER 13 MAGNETITE IN THE HUMAN BODY	
..... 54	
HUMAN LEVITATION.....	58
VIRGIN MIRI.....	69
HUMAN LEVITATION CONT.	71
ULTRASONIC LEVITATION IN ANCIENT TIMES.....	78
TORUS STONE TRIANGULATION LEVITATION.....	82
ANILINE CRYSTAL REVEALED	88
COGNITIVE DISSONANCE.....	106
SONOROUS ROCKS.....	107
CHAPTER 14 SUPERSTRUCTURE OF THE	
PYRAMIDS	
..... 111	
LIMESTONE INSULATION.....	113
“GREAT PYRAMID OF EGYPT ELECTROMAGNETIC	
GENERATOR”	120
TESLA INDUCTION MOTOR.....	123
ELECTRICITY DOESN'T TRAVEL	141
CHAPTER 15 TESLA COIL GENERATOR.....	
..... 149	
MAGNETOSPHERE.....	150
DELTA ▲ LAMBDA ▼	157
MAGNETOSPHERE CONT.	159

Cheops SPOKE Pt 2

CRYSTALS ARE NOT MADE OF ATOMS	160
ELECTROSTATIC INVERSION	173
CONTROL TEMPLES	177
DEUTERIUM HYDRODUCTS.....	185
WARDENCLYFFE TOWER.....	194
NIKOLA TESLA FBI FILE.....	196
CHAPTER 16 QUANTUM ELECTRODYNAMICS 199	
LIGHT QUANTA.....	202
GRAVITATIONAL WAVES.....	206
OSIRIS SHAFT	216
CHAPTER 17 THE TWO GREAT PYRAMIDS OF EGYPT..... 229	
CAVITY MAGNETRONS	231
HYDROPHOBES	239
INFINITE VECTOR.....	242
PHOTOMULTIPLIER	244
SYNCHROTRON	247
PARTICLE ACCELERATORS	247
CONTINUOUS NEGATIVE FEEDBACK LOOP.....	253
PHOTOCATHODE SUNLIGHT SHAFTS.....	257
CHAPTER 18 “SUBTERRANEAN HURRICANE” 265	
BRIEF OVERVIEW; HOW CHEOPS WORKS	275
STANDING SQUARE WAVES	276
MAGNETIC FIELD EXPLAINED	279
POWERING THE MAGNETRONS	280
RESONANT INDUCTIVE COUPLERS.....	292
THE TWO MAGNETRONS OF CHEOPS	296
ENGAGING THE MAGNETRONS	302
CHAPTER 19 THE TWO SYNCHROTRONS OF CHEOPS 307	
OPTIC CONDENSER	308
SYNCHROTRON PHOTOCATHODE WAVEGUIDES	313
DIORITE OMNIDIRECTIONAL CHIRAL SUPERCONDUCTOR	322
DEUTERIUM PHOTON ACCELERATOR	323

GREBENNIKOV LEVITATION

QUEEN'S CHAMBER AIR SHAFTS.....	327
COLD CATHODE GAS DISCHARGE LAMPS	333

CHAPTER 20 RADIANT ENERGY

TRANSPONDERS..... 343

D WAVE CONTROL TEMPLE.....	346
BLACK HOLE VORTEX SASER BEAM	351
RADIANT ENERGY HARVESTING TRANSPONDER TEMPLES	352

CHAPTER 21 HOW THE ENERGY TEMPLES

WORK..... 363

MASTER CONTROL TEMPLE COMPENDIUM	364
--	-----

CHAPTER 12

GREBENNIKOV LEVITATION



In the previous section I mentioned how one particularly dedicated scientist claims to have managed flight using the wings from a particular insect mounted underneath a wooden platform fitted with handlebar controls and nothing else. He went to great lengths in his book *My World* to apologize for not indicating exactly how his device worked and which species of insect's wings he used, claiming passionately how he didn't want to see this particular insect

Cheops SPOKE Pt 2

species harvested into extinction by humans possessed with being able to travel in the same manner he detailed carefully that he had.

I will mention now that the use of free energy (not to mention *levitation*) is not the private domain of just one man to determine whether or not the world will handle it with wisdom enough to satisfy his own philosophical standards. It was and is a human right and how humanity decides to conduct itself in its application is up to them. It is a shame he chose not to reveal his exact blueprints. This is the very thing that has held back this evolution for countless millennia due to certain beings who took it on themselves many thousands of times to dictate what the public could or couldn't have as if they alone were the god of creation. This handbook series is about giving the collective of mankind the decision on all such matters.

With that said, yes I absolutely do believe that what he learned through years of studying the architecture of insect wings did lead to his flying platform seen here. The why should be obvious by now. The raw science, is there:

TESLA COIL GENERATOR



Cheops SPOKE Pt 2

Here is a quick introduction to **Viktor Grebennikov**'s work written by **Juri N. Cherednichenko**, *Biophysics Scientific Research Institute of General Pathology and Human Ecology*:

*“Viktor Stepanovich Grebennikov - naturalist and a professional entomologist. He is also an artist and an intellectual with a wide range of interests and pursuits. He is known to many as the discoverer of the **Cavity Structures Effect (CSE)**. But very few people are familiar with his other discovery, the one that also borrows from Nature and its innermost secrets. He has discovered antigravitational effects of the chitin shell of certain insects back in 1988 but, the most impressive concomitant phenomenon he has discovered at the same time was that of **complete or partial invisibility** and/or of distorted perception of material objects entering the zone of **compensated gravity**. Based on this discovery, Viktor Grebennikov used bionic principles to design and build an **anti-gravitational platform** for hovering flights at the speeds of up to 25 km/min [this is 900 miles per hour]. Since 1991-92 he has used this device for his own fast transportation.”*

If you would like the full story on what he experienced, his book is now online and translated into English where it can be read from numerous websites. What I am interested in is showing you the science regarding insect wings, because some do, in fact, levitate. A hundred or so of them would easily levitate a human. And by now you already know that at certain temperatures, Orme monoatomic gold factually

TESLA COIL GENERATOR

disappears, no matter how SciFi that might sound. This is documented science-fact from tens of thousands of studies, not science fiction.

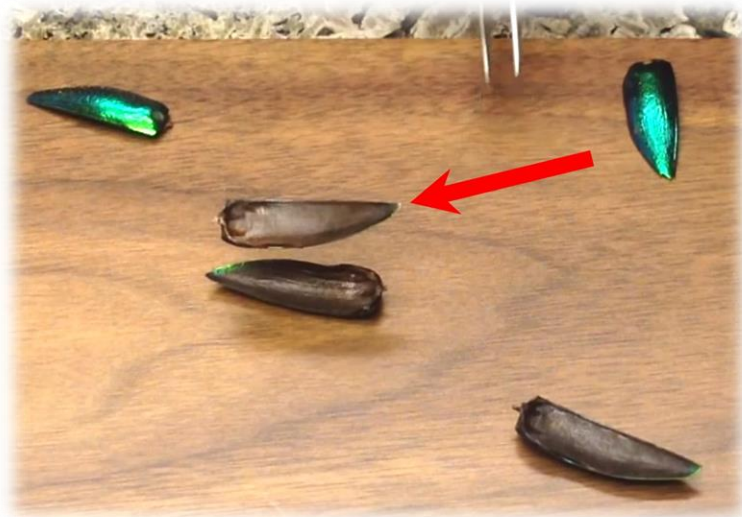

There is more to certain types of insects' levitation than just ultrasonic resonance and magnetic fields as has been explained in previous chapters in regard to flight, due to the fact that many insects are not actually "insects", but are in truth predator drones fitted with receiving/transmitting visual optics that allow the surveillance of the human experiment, brought here by the same invader races who manage the day to day operations of the enslavement agenda. Some are also used to spread pathogens and disease, used like tiny aerial assault crafts when the false gods are squabbling between themselves or there is a major species-cleansing that has been put into place.

Cheops SPOKE Pt 2

As I have mentioned previously, every animated biological organism on the planet represents at least one Sentient species of Avatar that in fact exists on other playing fields in other dimensions. One of these is the *scarab beetle*. You have heard this name in reference to ancient Egypt already from Hollywood productions and written about in ancient texts. The beings who placed this creature on-planet were known as the *Khepri* in ancient times, and today are referred to as the *Men In Black*, among others. You will see two of the half-animal/half-man Sumerians below, first Thoth the ibis, then to the right, the Khepri:

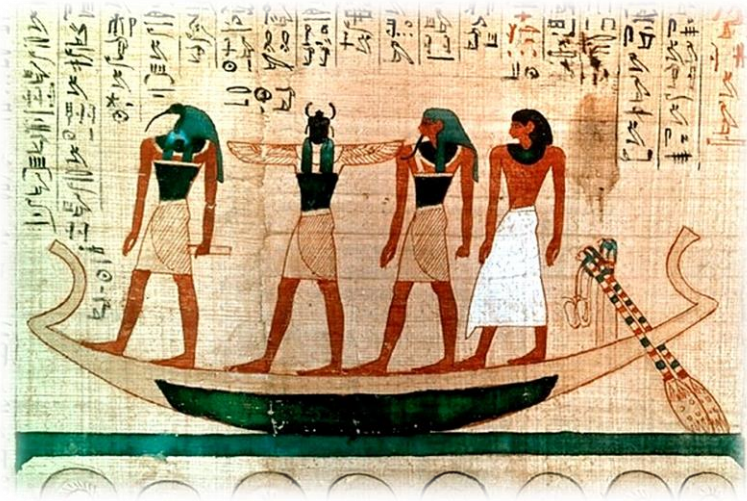

TESLA COIL GENERATOR



It is for this reason that I will focus on the Scarab beetle in my explanation of how this incredibly advanced biological robot functions and takes flight, even though its body is far too heavy to allow it to do so if using nothing but tiny flapping wings. The science will be roughly the same for all insects of flight, as the same hollow ultrasonic sound chambers are within the microscopic structures of their wings, shells and throughout their bodies. They are sonically levitated crystal warrior bots that just so happen to be animated to make you think they are just bugs.

Here is an excerpt from an article written about the lowly insect where the writer was attempting to shed some light on the beetle that was worshipped in ancient Egypt as the **god of the sun**. I want you to notice how flippantly he disregards pygmies as mythical and therefore imaginary

Cheops SPOKE Pt 2

without so much as explaining a thing about them. What if I showed you 100,000 photographs of real pygmies, would you believe in them then? We dismiss thousands of ancient reports as fantasy by debunking them without pause other than they are mythological fables:

*Matt Simon 7/09/14: **FANTASTICALLY WRONG:
WHY THE EGYPTIANS WORSHIPED
BEETLES THAT EAT POOP FOR A LIVING;***

*“Even the Greeks put it on a throne, claiming it was the king of the mythical pygmies—a race of tiny peoples at constant war with cranes (specifically the ibis bird, not the machinery)—and went so far as to associate it with **Zeus**, according to Cambefort. Later on in the 1600s, the **Jesuit** Athanasius Kircher claimed that the line from King David’s speech in Psalm 22:6 invoking Jesus’ lamentations on the cross, “But I am a worm, and no man,” could be read as “**scarab**” instead of “worm.” Also an **alchemist**, Kircher believed that the scarab was **the prima materia**, a substance required to create **the philosopher’s stone** that supposedly could turn metals like silver and iron into gold.”*

The king of the aviary kingdom in Egyptian times was depicted with the head of an ibis crane that the pygmies were at war with known as Thoth. Later both of these Sumerian species would join forces and form the Holy Roman Catholic Church where those original Khepri pygmies would become the standing army of the church known as the Knights Templars Men in Black, covered in

TESLA COIL GENERATOR

other volumes of this series. The church's coat of arms has depicted this species since inception.

In this report I am not going to focus on why "Jesus" would have mentioned that he came from the Khepri dynasty that arrived on planet Urth from Andromeda 570 million years prior to relocating to the lands immediately below Mt. Ararat after the last flood and to the Fertile Crescent of Babylon and Sumer-Ur, or why the first official name of the Templars was the *Poor Fellow-Soldiers of Christ*, but here's a hint:

*Wikipedia: **Nights Templar**;*

*"The **Poor Fellow-Soldiers of Christ** and of the Temple of Solomon (Latin: *Pauperes commilitones Christi Templique Salomonici*), also known as the Order of Solomon's Temple, **the Knights Templar** or simply **the Templars**, were a Catholic **military order** recognised in 1139 by the papal bull *Omne datum optimum*."*



REBUILD AND ASCENSION

This installment isn't so much about focusing on the invasion as it is the rebuilding of the resources placed here for the continuation of the human evolution for those moving forward during this ascension cycle; the Ultrasonic Energy Temples being perhaps the most significant one of all. This is the science that is intended to help you bring back some of the everyday comforts this civilization has lost. And no, those moving forward will not be going to some other place, but are staying right here to set up the foundations of the 4th dimension.

It is a mistake that ascension means leaving and non-ascension means being left behind. Both are leaving the way of life behind they have become

TESLA COIL GENERATOR

accustomed to, and both are leaving the host Matrix where they have been functioning. The ones who are choosing not to move higher within the 15 levels of their evolution will be taken as a collective to a new star system in the Weasadek Phantom Matrix that is designed without any higher or lower levels to their containment platform which has been engineered specifically as a permanent home for the Lost Souls of Tara who wish to continue along under “leaders and rulers” who will be more than happy to choose for them what quality of life they will be given.

Realize that the Gaia Time Matrix that has been host to the Angelic Human Krystos Project over the last 550 million years is now in fall and will be returning to source in just a few hundred years from now. That means all life forms inside of all dimensions within Gaia (5 planets and 15 levels or “Dimensions”) will have to evacuate if they are going to survive. The host planet of the 1st, 2nd and 3rd dimension, Particle Tara, has already exited that Time Matrix and is making her way to a new host platform in the Aqueous Sun Time Matrix where she will once again take the position of hosting the 4th, 5th and 6th Dimensions. This is known as the “2nd Density” within a 15 Level Time Matrix.

At the end of 2012, the Antiparticle, shadow of Particle Tara began phase-shifting into the reality

Cheops SPOKE Pt 2

field of the planet you have been on. By now you already know that all “particles” have antiparticles; from neutrino leptons to atomic electrons and antielectrons. Tara is no different.

Here on Particle Tara, you have two Avatars while you are alive. One is male, the other female. These are called Twin Flames. Fractals of your awareness are inside each one, living out their lives independently from one another. There on Antiparticle Tara, you have mirror images of both of these individual-yet-connected versions of yourself that are evolving while the other two of you have been evolving here, which has to do with speeding up the process of knitting back together your fractalized Akashic records of your history and identity within the Sphere of Amenti. By having 4 of your awarenesses living out their lives independently, you are reaching wholeness 4 times as fast as you otherwise would have achieved.

When Antiparticle Tara began its integration with Particle Tara at the end of 2012, your awarenesses from both planets also began to merge together, making you believe that you are still the one same individual. Yet at that time when the phase-shift began, you suddenly became different.

TESLA COIL GENERATOR

For some, this was a major change, for others, not so much. Still, your life did change significantly at that time due to the differences between these individual expressions of yourself now sharing two awarenesses per single body. Your female selves merged with their counterpart, as your male selves did at the same. From that point forward, all four of you have been deciding which is the best direction for you to take going forward.

When the separation completes, only one of your female self and one of your male self will be going forward, either into the next higher level of awareness, or continuing on in the 3rd Dimension. Where “you” go will be mirrored by your Twin Flame. So you will both go to either one of the two respective destinations “together”. Your Antiparticle twins will permanently be absorbed by the stronger or “more resolved” one between the two. The “meek” who choose not to stand up for what is morally correct with true conviction will indeed “inherit the Urth”, just not Particle Urth. Those moving ahead will do so only because they took a stand and refused to bend their knees to unfair rules that only serve their false masters.

Obviously, Antiparticle Tara has also left the Gaia Time Matrix as well when Particle Tara parted from the old Matrix at the end of 2017. That planet is being pulled in the direction of the black hole at the metagalactic core of the Milky Way galaxy,

Cheops SPOKE Pt 2

while Particle Tara is being pulled in the opposite direction toward the Aqueous Sun. The black hole Antiparticle Tara is moving toward is the rip in the spacetime fabric that took place 568 million years ago when beings from that Matrix invaded the Gaia platform. It will act as a stargate entry into that holographic operating platform for Antiparticle Tara.

Those who seek higher education and spiritual growth will remain on Particle Tara. Those who don't will be moving away from "positive reality" on Antiparticle Tara. Their exit from this plane will be seamless. The only thing they will notice at the moment of separation is that some of their loved ones are simply no longer there. Those who will brave forward to establish the next chapter in the development of the Angelic Human and the new hybrids on their way up to Krysting or "ascended mastering" will remain on particle Tara to build the new infrastructure of a world without war, poverty, scarcity or totalitarian rule.

While the 4th Dimension "already exists", it only exists because someone cast it into reality. And just like the first boots on the ground in cave-man times in the 3rd Dimension, those who will be building the new Dimension will be the pioneers of that level of the Matrix. Think of this as traveling back in time to arrive at the opening scenes of the 4th Dimension if you will.

TESLA COIL GENERATOR

You will have free energy and unlimited access to all resources, but you will have to bring them into use in a balanced fashion if you are going to be trusted to use them without monetizing or weaponizing them for personal gain. The magic money system will be replaced by universal abundance where there will be no need to hoard anything ever again.

The physical transition is happening now and will finalize in a very few years from the penning of this report. As of the end of 2017, we are now over the “peak” center of this very short “10 year” window. The remaining time Particle Tara has to complete her ascension will be dictated by the positive energy produced by the fractals of god within her collective frequency. The more you work toward setting up the new dimension and away from enslavement now, the faster that will happen. It could still be another couple of years, or 10, depending on you. The celestial processing of the transition is not fixed within ridged chronological “time” as you are familiar with, but is an energetic ebb and flow based on the elevating awareness of the beings involved in the ascension. The 10 year process of organic ascension is merely an estimate based on the current state of the human collective consciousness.

GREBENNIKOV LEVITATION CONT.

In the last sentence of Matt Simon's referenced text above, he points out that the **alchemist** Kircher had connected the scarab beetle (which represents 6,000 different versions of the same insect, all just various models named differently, but each one still a "Scarab" –Khepri- beetle) to somehow carry the substance we have already covered previously here, the *Philosopher's Stone*. While it was never actually supposed to turn noble metals (Bismuth) into gold, it was supposed to turn them into *monoatomic gold*.

So where does this student of the Occult Kircher get his inspiration from that the Scarab carries the mineral to the most elusive of all Hermetic mysteries? In its shell. Referred to previously by the physicist that wrote the introduction for our friend who claims he can use parts of an insect to fly and become partially invisible; the *chitin*.

The chitin shell of the Scarab beetle is iridescent, meaning it has an unusual, multi-colored pearl essence that comes in many different colors. This spectacular sheen is found on many sea creatures such as the abalone as well as insects of flight. From butterflies to armored wasps we see them sparkle in the sunlight, but the jewel Scarab beetle lineup of invader bots holds the prize for the most iridescent of them all:

TESLA COIL GENERATOR



As elements go on the periodic table, what our little friend here is hiding can be considered something of the *holy grail* in so many words. At least when you are talking about energy in both its atomic form (ions) as well as its electromagnetic form (electrons). And in science-speak, energy has always been the biggest prize of every find. The more energy you have the more amazing things you can do, not just for toasting bread, but on the battlefield as well. Gold is pretty, but that's not why it has been so coveted across time as you have learned here, it was because it yielded Orme. And Orme isn't just desired by invader races back on their home planet, it is required for that species to even continue to exist at all. Without aerosoled

Cheops SPOKE Pt 2

monoatomic gold in their air, Nibirueans, as a species, would *die*. Today, monoatomic gold is equally coveted by modern science right here on Urth as it is in the innumerable enslavement applications used by our visitors from elsewhere.

But gold isn't the only substance that produces monoatomic "gold", as pointed out by the man who spent millions to patent it. While his material he claimed to possess "tons and tons of" on his property wasn't gold, it still managed to yield the highest concentrates of the noble metals (including gold) ever found once it was broken down into its many other minerals on its way to the ultimately pure, single-atom form of the substance. He never revealed what that material was, but I think it has become obvious exactly what it was he was excavating from his Arizona property. The alien crystal Bismuth.

In our search for *the* magic material over all others, perhaps we will find not only a connection between it and the scarab, but also shed some light on that beetle at the same time.

Any temperature above absolute zero is created by a *sound*. 73 degrees is one sound, and 1500 degrees is another. You can create that sound using the *form* of energy of your choice. You can generate it using fire, or the frequency of sun waves, or merely exciting enough electrons flowing through a ferro-metallic surface to cause the

TESLA COIL GENERATOR

electromagnetic friction needed to achieve it, your choice. But you can also hit that precise sound using ionic piezoelectricity (phonons) to reach it as well. When in *radiation* form (fire or electromagnetic electrons) you have a temperature that interacts with other material things in a “*thermal*” manner. When in stasis form (ions, static, etc.) it reaches the same pitch but will not generate a fire. When the sonic frequency code of “fire” is reached, it will instantly boil water, but since it won’t generate a spark, open-air Dark Matter will not be present.

When we create sound using *unshielded energy*, such as when air “breaks down” and allows ions to leap out of their protective Aniline crystal shell and through the air to enter into “electron form” and then back down to ground, it generates a spark and that spark always carries with it its precise sonic resonance. Remember, the transition from ionic, stasis energy into electromagnetic energy, and from electromagnetic energy back into ionic energy always casts a *secondary emission*. When allowed to reach open air, electron emission always travels in the form of heat and always in the form that harms. You will hear a zap with small signatures, and a massive boom we call thunder claps with large ones. When we create sound using shielded energy, such as when we strum a guitar using our totally shielded body, then the sound is no longer in *hysteresis* (hysterical) form, but in harmonic symbiosis with life. This is because *radiation* is only another word for *Dark Matter*, which is the form of energy when not in control. So you can think of fire as the “visible” form of Dark Matter. And the flames, while in visible form *never casts a shadow*,

Cheops SPOKE Pt 2

because it is not matter, it is Dark Matter. Or, the *shadow of matter*:



No shadows:

TESLA COIL GENERATOR



Fire radiation creates heat, however the invisible waves coming off the sun do not, as previously mentioned. Those sound waves interact with ions that strike the *frequency* of “heat” that causes the crystal inside the air to heat up, just like in a ceramic space heater, but the waves striking that crystal does so without carrying with it *open-air heat transfer* associated with radiation, or *radioactive* waves. The waves from the moon carries zero radiation as has been proven thousands of times in the moonlight cold fusion test shown in previous volumes of this handbook, showing you that kinetic frequency waves can emit a sound that activates Aniline crystals in ions to illuminate without any heat signature of any kind. Direct moonlight is literally colder than the shadows under a full moon.

Cheops SPOKE Pt 2

Dark Matter electron heat can also cause crystals to strike the note of invisibility, zero gravity, and create a force field around them impervious to other weaker torus fields, just like ions. So the Orme monoatomic gold reached that “*invisibility note*” through applied *radiant heat*, and Viktor Grebennikov’s chitin shells reached the same note through *dielectric paramagnetic frequency*, only without the thermal signature.

While the Orme was visible on the weighing scales of the assay lab and had not yet reached the right temperature to turn invisible, yet had already cancelled out gravity, it was still visible and cast a shadow. When it reached the precise *invisibility note*, it disappeared, ***and so did its shadow***. This shows that the frequency of levitation is different from, but close to, the frequency of invisibility. Victor reported that sometimes he and the platform turned completely invisible while he was suspended, and other times at much lower elevations and slower speed, he was partially invisible. Once he had slowed down to land, the invisibility went away each time and his shadow returned.

When any form of “*matter*” generates that precise sympathetic harmonic resonance, it turns *photonic* or into pure light, like a time craft when it cycles up to the energy needed in order to translocate. It is now no longer *on the inside* of one dimension, but suspended outside of material manifestation and *looking in* one can say. While “here” in essence form, it will be seen as just more light in the daytime sky, and at night, it will appear as visible light that doesn’t carry a thermal signature. Victor reported that when

TESLA COIL GENERATOR

it got dark, for some reason, instead of just being invisible, now the field around him turned into a glowing orb that had been reported to the newspapers numerous times after he had been spotted going over residential areas at night.

I am personally familiar with this, because my contact has appeared to me before when she traveled in spirit form which allows instant translocation, (explained in biblical times as angels appearing as wheels within wheels) which uses the same zero-point Meissner Field, so I am not guessing at what it looks like to the naked eye. When she chooses to travel in photonic form, she isn't *in the 3rd or 4th dimension, or in a parallel universe*, but she is "looking in" this one as Victor was doing, only in disembodied form, so therefore merely appears as light. Additionally, the local airports were contacted by news reporters to find out if they had spotted anything in that area at the times when Grebennikov's sightings were made, to which they had detected nothing (since their radar systems are unable to identify merely light).

MONOATOMIC NOBLE METALS

Below is *the most piezoelectric (highest static electric energy) natural crystal on planet Urth*. It is also *the most resistive electromagnetic substance known to man (most diamagnetic)*. While it is a crystal, it is also called a metal. But there is a quality to this enigmatic material that belies its surface; when deposited in *thin layers* over thin layers of

Cheops SPOKE Pt 2

ferro-metal, it suddenly *changes from a perfect non-conductor* (of electromagnetic electrons), to a ***semiconductor***. Just so we get our terms straight, a semiconductor is a solid material that is partially conductive of electricity as well as ions). Materials that are electromagnetic conductors (for electrons), are metal, and materials not readily affected by an electromagnetic field are insulators called electro-reluctant. Shown below is both, and can be used in either way in temperatures where all others fail:

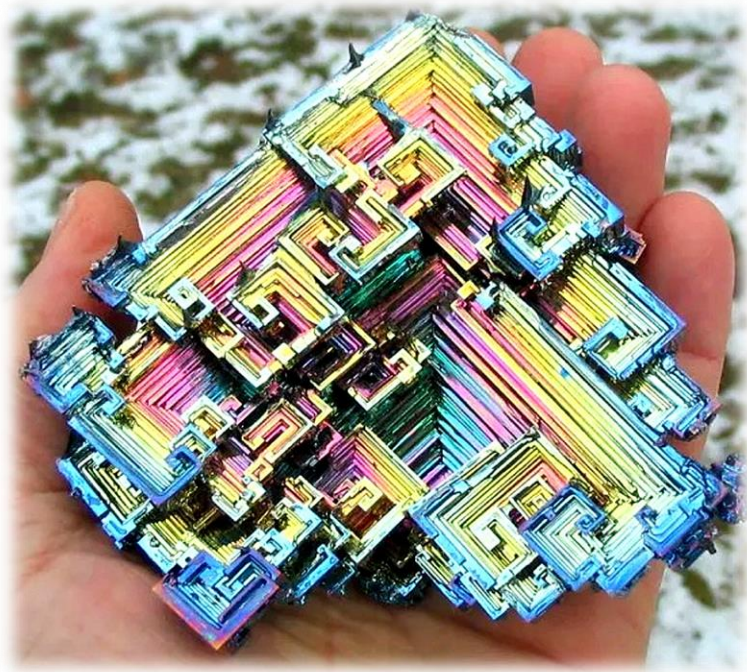

The spectacular alien crystal above actually grows like this in nature. I'll bet you never saw that on the front page of

TESLA COIL GENERATOR

your newspaper before. I would also lay even money that you were never told that this material that makes gorgeous, high-end dinner plates and other eating utensils happens to be *radioactive*. Something that seems to go completely unnoticed by everyone busy using them in thousands of products from lipstick to the talcum powder we've already mentioned you pat onto your baby's bottom with which has been proven in court to cause mesothelioma & ovarian cancer to name only a few of its harmful effects.

In Feb. 2016 a court ordered **Johnson & Johnson** to pay 72 million dollars for causing fatal ovarian cancer with its Baby Powder. In Aug. 2017 the same company was ordered to pay out another 417 million dollars for the same thing. In July of 2018, they were issued yet another judgement of 4.69 *billion* dollars in damages in one class action suit. More than 2500 suits are currently on-calendar against the same company who knew when they first began producing talcum powder that it was radioactive. Totally safe cornstarch would have served the same purpose. Just wait until the public finally figures out that every time they climbed into a passenger plane, they were sitting inside a coffin filled with radioisotopes. Of course, this is only the very tip of that Titanic iceberg: gold, silver, copper and many other materials extracted from Bismuth are known as producing what else? Radon; which factually causes lung cancer. Funny how they never mentioned that when they rolled out all the numbers of lung cancer coming from "tobacco".

Cheops SPOKE Pt 2

It is little wonder why cigarettes all of a sudden began causing “lung cancer” after the big tobacco companies began growing tobacco using apatite as a “fertilizer”. Apatite decays into Polonium-210, the same thing as nuclear waste known as fluoride that is added to all the water reservoirs across America along with nearly all toothpastes, baby formula, “baby water” and hundreds of other covert delivery devices. Well-known cancer-causing Polonium-210 is better known as lead, also known as Bismuth.

Modern science openly admits that Egyptians certainly did know about this crystal, which is why there is no geologist who can take credit for its discovery. Perhaps you have seen this somewhere before? Maybe in ancient architecture?:

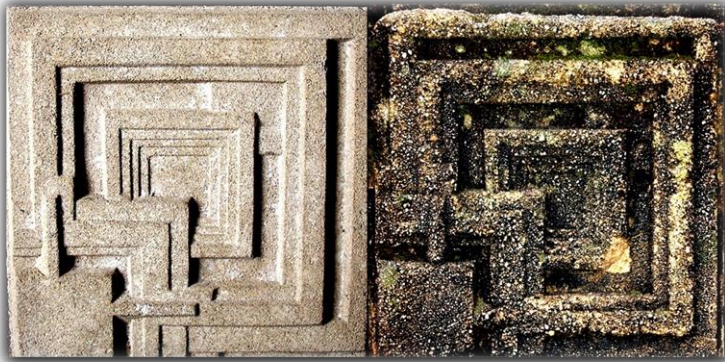

Bismuth has been characterized as the single most non-conductive material known. It has also been found to

TESLA COIL GENERATOR

continue producing piezoelectricity to “*unbelievably high*” temperatures. In semiconductors it continues to process electrons at “*unbelievably high*” temperatures as well. Where ferro-metals *decrease* in their ability to transfer electromagnetic energy the higher and higher temperatures reached, semiconductors *increase*. Just the opposite. The nature of this “ferro-metal-yet-crystal” (a contradiction in terms), is so stable processing fluctuating magnetic signals, it is considered the first choice remedy in thousands of applications that are fraught with what is known as “hysteresis”, which is defined as the *magnetic moment* at which a magnetic field breaks down. Bismuth, for some reason, causes those magnetic moments to all line up and flow uniformly from one capacitor or resistor into the next. No other material can do this. And although Bismuth carries the atoms of gold, silver, and copper, the three most exclusive of the noble metals, it is listed on the Periodic Table as merely metal, even though it is actually glass-like crystal.

As far back as 1988, Bismuth was shown to be the number one material in superconductors to function at the highest temperature range. Hmmm, superconductors, really. Of everything you might be able to glean regarding mineral substances from this report, Bismuth alone is the most spectacular element of them all. You will see why more clearly as we go.

Materials on the Periodic Table are measured in many ways, but ultimately it comes down to the ions held within their valence bands that tells science how that chemical will

Cheops SPOKE Pt 2

respond. The incredible coincidental numbers of anion ions (*incorrectly* called electrons by science) within the **core** valence bands of the three “*truly noble” metals gold, copper and silver when compared to Bismuth look like this:

- *Gold: **2, 8, 18**, 32, 18, 1 = atomic number 79
- *Silver: **2, 8, 18**, 18, 1 = atomic number 47
- *Copper: **2, 8, 18**, 1 = atomic number 29
- Bismuth: **2, 8, 18**, 32, 18, 5 = atomic number 83

Literally the only difference between Bismuth and gold is the final valence band between the two where gold is 1 and Bismuth is 5. It holds within its structure the same number of ions within its different valence bands as all three noble metals, finishing with a “pentavalence”, or the exact same number as the points of the **Anunnaki Particle** covered at great length in volumes 3 and 4 of this series. You might want to keep this in mind while considering exactly what material it was that David Hudson, the discoverer of Orme white powder gold was working with, since it produced white powder gold *without* using gold to get there, and that one **room-temperature superconductor** material was found to carry within it through many different smelting reduction processes to contain *gold, silver, copper, ruthenium, rhodium, palladium, osmium, iridium and platinum*. Outside of copper, you may as well just list off **the most valuable metals known to man**.

TESLA COIL GENERATOR

All **three** official *noble metals* share in common with each other the first three ion-count numbers of **2, 8, and 18**, with each one ending in the count of **1**. This corresponds with Bismuth's 2, 8, and 18, then ending in 5. With this in mind, now take a look at the number of ions held within the valence bands of these other incredibly exclusive and rare materials found in Hudson's secret mineral. This, by the way, happens to be the **complete list** of all the rest of the metals that have been found to reduce down to **monoatomic, white-powder gold**, besides gold and silver:

- Ruthenium: **2, 8, 18**, 15, 1 = atomic number 44
- Rhodium: **2, 8, 18**, 16, 1 = atomic number 45
- Palladium: **2, 8, 18**, 18 = atomic number 46
- Osmium: **2, 8, 18**, 32, 14, 2 = atomic number 76
- Iridium: **2, 8, 18**, 32, 15, 2 = atomic number 77
- Platinum: **2, 8, 18**, 32, 17, 1 = atomic number 78
- Bismuth: **2, 8, 18**, 32, 18, 5 = atomic number 83

Not only does Bismuth carry all the core ion counts within the first three and sometimes even four valence bands of all three noble metals, it also carries **all six** of the rest of the noble metals yet not listed as such on the periodic table that have been found to be reducible down to mono-atomic, single-atom state which just so happen to be every single one of the precious metals found inside Bismuth according to their valence numbers. The core ion count of a crystal dictates the fundamental nature of that crystal, whereas the

Cheops SPOKE Pt 2

outside valence band ion count dictates the way that isolated mineral behaves. Thus, every mono-atomic metal known to man is held inside Bismuth.

But our comparison does *not* stop there. **In 1980**, American scientist **Glenn Seaborg** turned **Bismuth** into bona-fide, actual gold, independently of the David Hudson reduction series that took place over many years of assays in the previous decade. Proving that Bismuth is gold, and it is silver, as well as all other true mono-atomic metals that turn into white powder at their quantum atomic state. Now, let's take a look at the name Bismuth to illustrate **the most colorful crystal on the planet**, according to Wikipedia:

*Wikipedia: **Bismuth**;*

*“The name comes from the German 'Bisemutum' a corruption of 'Weisse Masse' meaning **white mass**.”*

White? Mass? When this is not only the most exotic, 3 dimensionally-geometric, but also the most multi-colored, iridescently dazzling crystal ever found? Of course you already know why; it alone carries all known species of minerals that can be reduced down to the essence of antigravity, invisibility and time-cancelling, single-atomically-structured, white-powder used by the gods. With it, they achieved seeming immortality, to know what anyone is doing at all times by turning invisible (GOD and Santa) and to conjure up the infinite power of the aether upon command.

TESLA COIL GENERATOR

Once you realize that “Jesus” was claimed to be of scarab beetle descent, this takes a slight twist. Where he was quoted as stating in Psalm 22:6: *“But I am a worm, and no man.”* is more accurately translated as *“But I am a beetle, and no man.”*

St. Augustine (354–430) who lived in Roman Africa (present-day Algeria) is quoted as stating Jesus is the scarab (dung beetle):

“My own good beetle, not so much because he is only begotten (God), not because he, the author of himself, has taken on the form of mortals, but because he has rolled himself in our filth and chooses to be born from this filth itself.”

St. Epiphanius is also quoted as saying:

“Christ is the scarabaeus of God.”

In ancient Egyptian texts, classical literature, Aramaic and rabbinic sources, post-biblical texts and archaeological material suggests that “slsl” in the Pentateuch means beetle. This is merely **Isis** backward, the very name of the matriarchs behind the creation of the Atom and Eve Lulus.

Interesting is the fact that scarab beetles are made out of virtually 100% Bismuth, and Bismuth reduces down to pure white powder at its single atomic state, and is literally

Cheops SPOKE Pt 2

named White Mass, perhaps it will become apparent to you why you sing you are dreaming of a *White Christ Mass* each holiday season that is in honor of that beetle.

Unlike all other crystals that take as many as millions of years to cool down back into their aligned ion crystal directions back into dielectric status, Bismuth takes only minutes:

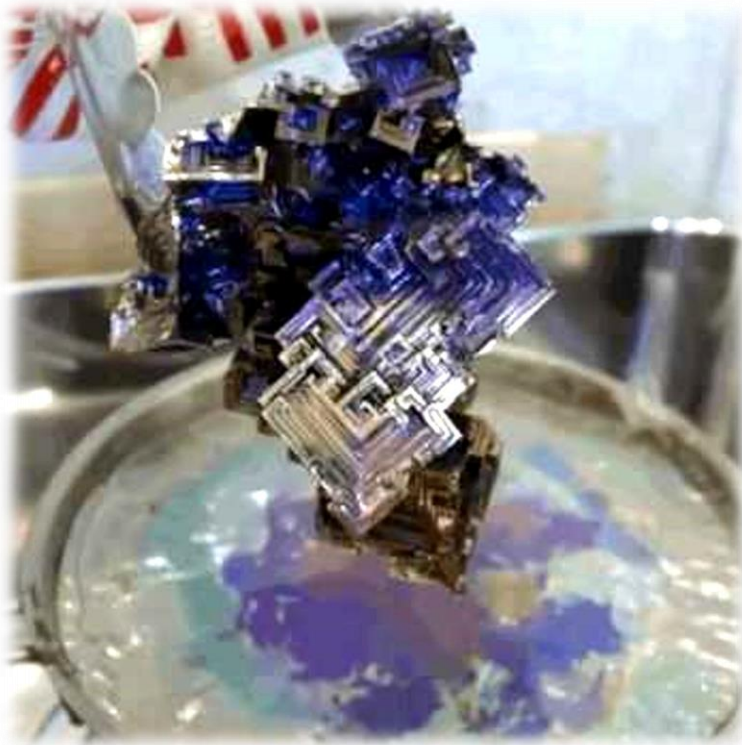

TESLA COIL GENERATOR

Bismuth has an incredibly high resistance to magnetic fields (termed *giant magnetoresistance*), while at the same time is able to process electrons, depending on how you apply it. Which makes this material not only a conundrum, but stunningly the most sophisticated semiconductor known to man. And we will get to the *sophisticated* part of that statement a bit more in a moment.

I had intended explaining just what makes Bismuth so valuable in my own words for you, but for this section I will let science do the talking with snippets of a technology report below. I think the title of the paper will be adequately self-explanatory:

*Sciencealert dot com: **Superconducting Bismuth Is Real, And It's Forcing Us to Rethink The Nature of Superconductivity;***

*“Scientists have discovered that at a fraction of a degree above absolute zero (-273.15°C), **Bismuth** becomes a **superconductor** - a material that can conduct electricity without resistance.*

According to the current theory of superconductivity, that doesn't make a whole lot of sense, because for 40 years now, scientists have assumed that superconducting materials must be abundant in free-flowing mobile electrons. But in Bismuth, there's just one mobile electron for every 100,000 atoms.

In general, compounds that exhibit superconductivity have roughly one mobile electron

per atom, Srinivasan Ramakrishnan from the Tata Institute of Fundamental Research in India explained to Chemistry World.

However, in Bismuth, one mobile electron is shared by 100,000 atoms – since [the] carrier density is so small, people did not believe Bismuth will superconduct.”

*The 'carrier density' of a material describes the number of electrons per volume, and the discovery that Bismuth has superconducting properties makes it the **lowest carrier density superconductor ever found** - breaking a 50-year record held by strontium titanate.”*

As far as scientific papers go on any one topic (and trust me, I have been over so many of these I have lost all count by now), there might be a few (3 or 4) available online on a given subject. But when entering the letters “**Bi**” into a search engine (the scientific symbol for Bismuth) along with the word “*superconductor*”, **567 thousand** papers come up. You may not know what is inside a superconductor, but in the world of superconducting, they do; Bismuth. And it could be thought of since 2016 in that real sense as the *god particle*, as I do equate it to the material on-planet that is in direct association to the *Anunnaki Particle*. And while they will admit that it works as a superconductor at just above absolute zero, they aren't mentioning that it also works at room temperature (and above), as explained by the patent holder of Orme (ormus) about his unique mineral. Even super-cooled

TESLA COIL GENERATOR

superconductors are difficult for them to admit to existing at all.

And what makes Bismuth so incredibly ideal for predator drones as well as for the production of superconductors and monoatomic gold? Bismuth is known as the substance that **expands** once it hardens from a liquefied (molten) state, making it perfect to fill in the corners and crevices of molded metals, such as aircraft aluminum, and besides being the go-to material for shiny, iridescent makeup and fine dinnerware, it is the primary ingredient in *all things molded*. And unlike quartz crystal that requires millions of years to grow, Bismuth can be manufactured in hours right there in the lab with a *hot plate*.

Immediately that might not seem so spectacular until you realize that Bismuth automatically compresses piezoelectric crystal greater than 0.1% to apply the pressure needed to keep that crystal emitting constant energy like an active generator.

As just covered, Bismuth is the number one most piezoelectric substance on the planet, or has the most ions inside that constantly generate free energy when exposed to sun waves and is equated to the most oxygen-producing element on-planet. Predator drone wings and skeletons, hair and jaws are made from this form of calcium crystal. They don't even have to *flap their wings* to levitate, but merely to propel themselves forward. In order to lift off, all they need

to do is spread their hard chitin wings open to allow sun waves to reach their huge wings hiding inside from that light, which exposes their ultrasonic resonance chambers toward the ground.

LEVITATING BISMUTH PREDATOR DRONES

Not all insects of flight need their chitin shells, legs, torsos, heads, jaws and wings armored in pure, ultra-piezoelectric Bismuth in order to fly. But the ones that do, are *impervious to fluctuations in the magnetic field* generated by the movement of their wings that excites the ions in the vortex field surrounding them, allowing them to fly no matter if they hit a pocket of low-ionic flux or not. These creatures that may seem like merely biological life forms are the most advanced visible flying weapons in our air. They are impervious to electromagnetic pulse weapons, and can live through a thermonuclear strike that would kill millions of people along with all the life forms within a 150 kilometer radius (such as the Russian 50 megaton *Tsar Bomba* for instance). The same true genus as the cockroach (though not listed this way in entomology), the *Coleoptera* (likely the real name of Cleopatra) lineup of invader robotic predators are immune to ***all Urth pathogens and disease***. We consider them mere pests, but are actually mobile surveillance and biological warfare dispensation drones. They are not here to merely roll feces into little balls for our amusement. In the case of the more streamlined Scarab we call the cockroach, it can survive for **weeks** *without a*

TESLA COIL GENERATOR

head. The rhinoceros model can lift the equivalent of a human holding up seven double-decker buses in the air. Or, something on the order of an *uber*-superman.

This predator drone levitates like butterflies, bees, houseflies, and all other insects that can fly: using ultrasonic levitation. These are Budhara Bourjha *cyborg* nanites in massive form.

Inside the wings of such creatures (many of which are actually predator drones, just like the typically benign Scarab lineup, such as the common fly, wasps, mosquitos and all other insects that are prone to harm through disease or attack without provocation) are microscopic hollow sonic chambers that work exactly like a magnetron. Not all flying insects are predator drones; butterflies are here to spread beauty and bring harmony to the ecosystem for instance, even though they also use the iridescent Bismuth super-conductor material. Others, such as the dragonfly however, in its illustrious uniform, are. All such exoskeletons (every leg, hair, shell and wing structure) are super-pressurized *calcium silica Magnesium Bismuth* that emit constant outgoing static electricity.

In this image you will see layers of both Bismuth and Magnesium taken from a downed alien craft:

Cheops SPOKE Pt 2



Extraterrestrial metal from bottom of a “wedge-shaped craft” between Sierra Blanca and San Mateo Mountains west of Roswell, New Mexico, in late 1940s, made of 26+ alternating layers: 1 to 4 microns dark Bismuth and 100 to 200 microns silver Magnesium/zinc alloy. Each of six pieces received from U. S. Army source were “formed” with a curvature that tapered. Photograph © 1999 by Linda Moulton Howe with Tim Bauer.

The above image was only found weeks or months after this chapter had already been written, so the existence of Magnesium being paired specifically with Bismuth to generate extremely hard, overunity alloy comes just as much a surprise to me as it might to you.

And just like aircraft aluminum that is obviously the same material used in extraterrestrial crafts that is mixed with Magnesium and Bismuth, predator drones carry in their chitin shells and throughout their bodies their own on-board sun-wave producing Magnesium which continually reenergizes their piezoelectricity day and night. In fact, the Coleoptera species (the Khepri Scarab beetle fleet) have been shown to produce high levels of Magnesium in their

TESLA COIL GENERATOR

dung, showing that their entire system is designed to *produce their own anion ions*. This is why their chitin shells levitate on their own, even after the beetle has been separated from the equation, and without flapping of any kind.

When they do flap their wings, it gives the drones control over their levitation as well as navigation. Like in birds, when these wings rotate or carve a spiral in the air, it creates sound. That sound enters into the hollow chambers which generates an accelerated rotational speed (powered by the piezoelectricity), which amplifies the sonic signature by 100,000 times and all of the chambers then combine to create one resonating sonic wave that releases even more piezoelectricity gathered from the ions in the air around them. That energy fills up the *crystalline frame* of the wing, legs, chitins and antennae with very high static-electricity which creates an electrostatic torus field that connects both wings and the entire body of the insect within a Meissner Field, generating an antigravitic zero-point field where both gravity and time are suspended. Now their zero-point field is able to lift both their wings and the mass of their bodies. While in flight, as long as that field continues, that insect cannot die by natural aging, because it is *suspended outside of time*. The dragonfly class of this predator drone can fly *11,000 miles*, or almost half way around the planet which is further than the longest-distance jet aircraft:

Cheops SPOKE Pt 2

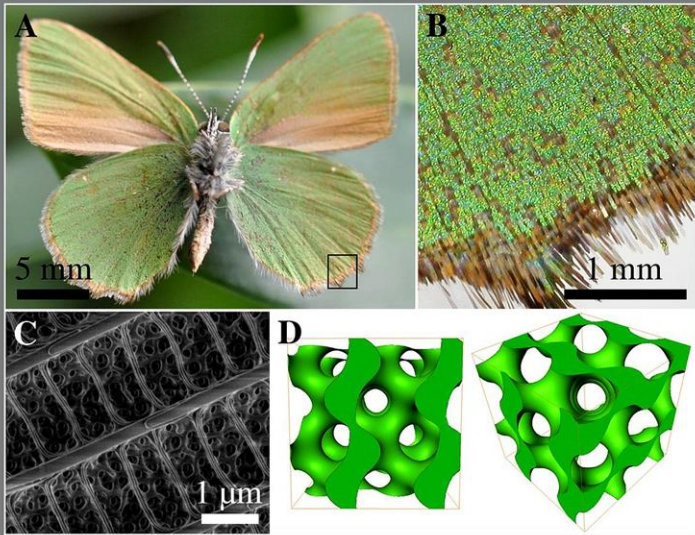
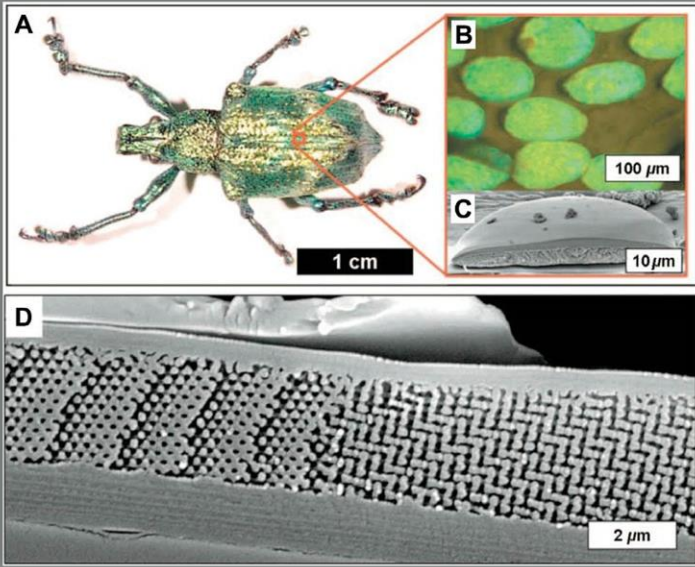

TESLA COIL GENERATOR

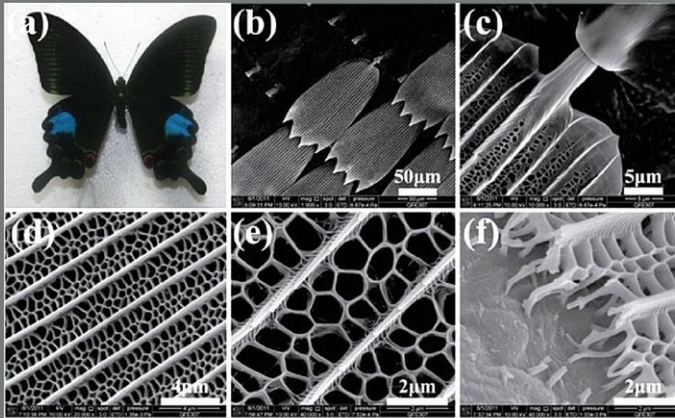

Now back to our story about the man who could fly.

Or should I say the entomological scientist Viktor Grebennikov who had been studying antigravity phenomenon in his laboratory for decades that learned that the exoskeletons and wings of insects emitted not only powerful piezoelectric energy fields, but that they also somehow had the ability to resonate when placed together, which accentuated the phenomenon.

After great efforts contemplating why the mud nests of bees generated their own heat in a vertical column above, and how those empty hollow chambers were strikingly similar to the chambers he had been seeing all over the insect world, he conducted many experiments, only to find that some of these energetically powerful wings and shells

Cheops SPOKE Pt 2

would simply suspend one or the other above at a precise height, almost like they were fused together, but with a space in between. At the time, back in the 1960s, he would not have any idea of what quantum locking was, yet what he witnessed was precisely that, quantum levitation that binds the superconductor to the diamagnetic, paramagnetic substance above. At that time some 50-odd years ago there would be no doubt that Grebennikov would be dismissed as nothing more than a mad scientist and disowned by the scientific community upon his claims he could fly. But today, when superconductivity is being studied in thousands of laboratories everyday around the world, he isn't just being taken seriously; science is studying closely everything he ever published. Under a search specifically only for scientific studies, "scientific" "reports" "Grebennikov" brings up over **9000 results**:

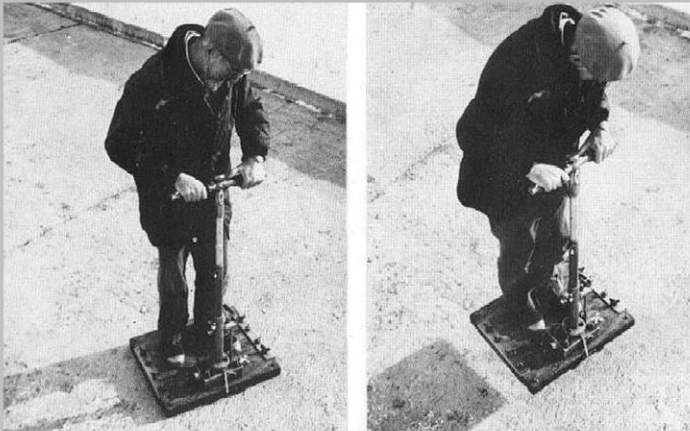

TESLA COIL GENERATOR

Viktor later contacted a local newspaper about his invention where they took video of him actually riding this device. Soon after word got out, the Russian secret service raided his home and took all of his plans and suddenly the video footage was gone. The next thing the Russian military had their own levitating vehicle with no visible propulsion of any kind. On liftoff, there is no displacement of air, the platform was completely silent to human ears, and it was so stable that beside wearing a simple helmet, the demonstration pilots didn't bother with protective gear or even a parachute. This photo is showing the platform relatively low to the ground, but it isn't limited to any height from the looks of the videos, and the speed it will travel is almost unthinkable. This was not a hoax:



Cheops SPOKE Pt 2

Here is a look from the back which shows there is no room below the platform to allow any kind of propulsion device that would be thicker than few beetle wings positioned one above each other:



Of course since these early days when Viktor finally revealed his story in *My World* in 1997, thousands of would-be levitating scientists have seen the same thing he did in their laboratories, beetle wings can definitely go into quantum locking. Here is another look at the self-levitating, Magnesium Bismuth iridescent beetle wing hovering under its own power. Something it will do perpetually. In the video this was lifted from, he was passing his tweezers between the lower wing and the one that was suspended in the air to show there was nothing between them. If he didn't have the wings perfectly centered to each other, then

TESLA COIL GENERATOR

the upper one would be repulsed by the other and sent off across the table like two magnets of the same polarity:

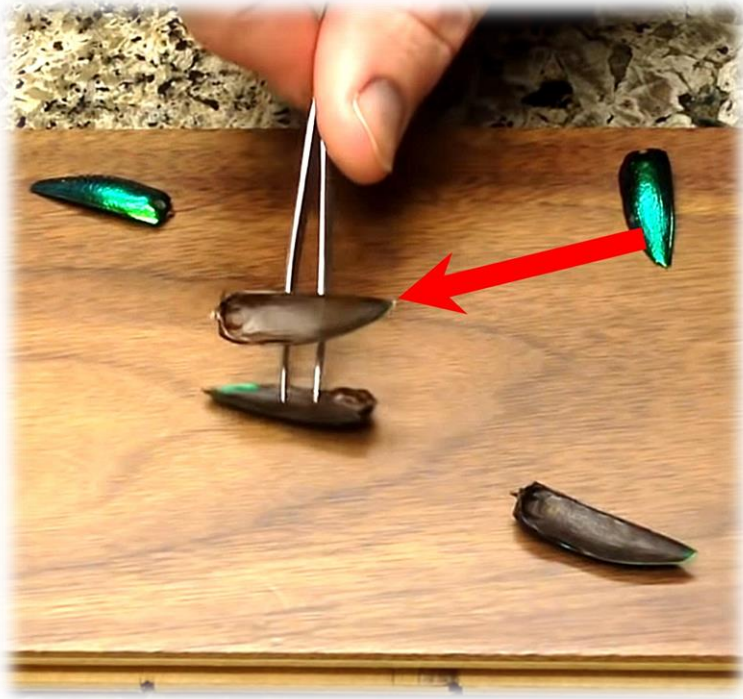

While I can't show you the science and pictures to prove such statements such as beings turn photonic and do not cast a shadow while in a zero-point field, I do know that our shadows only appear while we are in manifestation. Peter Pan while in flight had a conundrum over keeping his shadow attached to his body according to the story. A story that was merely an adaptation of true events that led up to the penning of that version of what actually transpired and then misinterpreted and distorted down through history. A shadow is Dark Matter, and the energy that casts the

Cheops SPOKE Pt 2

holographic projection of something vacates existence as long as that thing is manifest (powering that projection). When it is no longer manifest, then the energy returns to the Urth, casting Urth's hologram in the place you once stood. Hence, why light simply does not cast a shadow. The levitating shell above does cast a shadow, since it hasn't yet reached enough quantum energy to turn completely photonic until it has been surrounded by additional shells to generate that resonant field.

While Bismuth crystalline minerals aren't necessary for insects to use the ultrasonic resonance and ionic toroidal flow that brings on a Meissner Field, it certainly helps. The ultra-piezoelectricity from what science calls *elytra* (the chitin shell) of the Scarab is powerful enough to generate the entire process of levitation, only strengthened by the wing movement of the beetle to generate even more energy allowing it to lift their heavy bodies and then fly with more control. Viktor placed his Scarab (likely jewel beetle) chitin wings stacked atop each other to harness this incredible power, and by doing so, sent the magnetron ultrasonic waves out of the one wing which then combined to the signal of the one directly above to create a Saser standing scalar wave that could be increased just by allowing those shells access to more (indirect) sun waves using a screen below the platform which acts to excite the ions similar to the flapping of dielectric, paramagnetic crystalline wings. By placing hundreds of such pairs together under his platform, the power was easily enough to propel him upwards and forwards at virtually any height and speed he would have the intestinal fortitude to attempt.

TESLA COIL GENERATOR

While within the ionic Meissner Field and actively piloting the platform, this created a powerful electrostatic magnetic field around him, which erased not only all the magnetic-reactive film inside his camera, but also the backup film he had in his pocket so he could take photos while in flight to prove his claims. And it was the same field that produced an invisible force field (laminar air) around him that shielded him from the wind while in flight. The same force field that surrounds aeroplanes as well as birds and flying insects, keeping them from freezing into cubes of ice while in high altitude where it is as cold as *140 degrees below zero* from the wind chill factor of their flight, easily cold enough to freeze them solid.

Now I am going to show you the official **Hermetic, Alchemical symbol for Bismuth**. Let's see if you can notice any connection between this ultra-dielectric, ultra-high temperature conductor, ultra-piezoelectric metal that turns into a paramagnetic semiconductor (that speaks the language of crystal energy as well as electromagnetic energy) and compresses everything it is mixed with by more than 0.1% compression to activate eternal free energy as connecting it to the beetle worshipped as a god in ancient times.

Understand I am not showing you the scientific symbol for an insect, I am showing you the scientific symbol of the dazzlingly colored, iridescent, multi-faceted crystal that forms within minutes from liquid that was heralded as the

Cheops SPOKE Pt 2

Philosopher's Stone in ancient Egypt that carries the atomic valence number count of every single material known that can be reduced down to a single atomic state into pure white powder that generates a zero-point Meissner Field, vanishes and then reappears that was literally named *white mass*. Instead of looking like this:

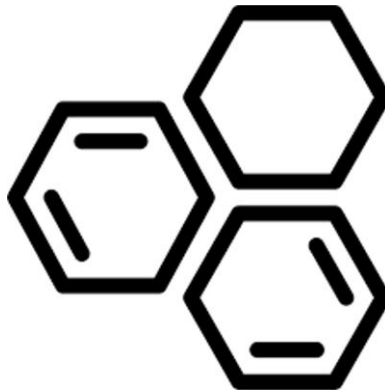

....it looks like this:

History [edit]



Alchemical symbol used by Torbern Bergman, 1775

The name *bismuth* derives from the Latin word *bi* (two) and *smuth* (metals to have been known as *Wissmuth* (early 16th century) and *bisemutum* (due to German *Wismuth* (17th century) times with tin and lead) in ancient times, so no one had observed the metal until the observation of the metal in the 15th century.

CHAPTER 13

MAGNETITE IN THE HUMAN BODY



Your body *creates* magnetite, just like Tura limestone once it has reached direct sunlight and exposed to the right temperature. This is explained in the paper;

TESLA COIL GENERATOR

Magnetite in the human body: Biogenic vs. anthropogenic from the organization *Proceedings of the National Academy of Sciences of the USA*;

“In the human brain, magnetite is also believed to precipitate biologically as part of the iron metabolism”

Organic magnetite produced by the brain gives your body a magnetic field, just like the neodymium magnets levitating over a superconductive capacitor that can resonate to the frequency of that thing, such as a superconductor, white Orme, or even a tuning fork. The tuning fork may not appear like a superconductor, but the energy waves coming out of it are sonic Saser beam waves, that push sound in the form of piezoelectricity. These are *audible photon (phonon) waves* and their electrons are all *holding hands* while in perfect resonant tone with a magnetic field.

This gives you an idea of just how criminally insane it is to make a few bucks on levitation technology with desk top toys instead of handing it to the world when all the right ingredients to produce levitation and even translocation are already right there inside the human body. If you think I am the first one to claim that people have the ability to levitate, you might want to check with the 100 million religious books in print all claiming the same thing. They just aren't going to bother mentioning the science that makes that possible.

Cheops SPOKE Pt 2

At the same time, if holographic and even physical translocation weren't really possible, then not only would historians not have ever documented countless visitations from people suddenly appearing out of nowhere, hundreds of millions of eye-witness accounts of the same thing, and my visits from a being I have been in personal contact with for over 5 years in both physical form as well as light form simply would not be presented for the mere fact that no one is going to make such a claim unless they witnessed it firsthand because doing so automatically registers a person as clinically insane to the world around them. Perhaps Enoch wasn't concerned about his reputation, but I certainly was. I would never make the claim unless I actually witnessed it, and would spend the rest of my life getting down to the science that would have to be used to make that make sense to me. When presented with physical facts, I need to understand what it was I just witnessed with my own two eyes.

All scalar vector points, or places around the world (and on every world), each have their own unique frequency signature, and if you know what that resonance is at say, 4th and Main in Topeka, you punch in that numerical entry just like an *IP address* into your sound resonance device that already knows your body's signature frequency to make a harmonic match, and that's where you will be through a Meissner Field and Cooper Pairing, *instantly*. Which shows you that magrav, subterranean supersonic bullet trains are actually clunky, outdated ancient technology compared to what your captors use to translocate (simply appear).

TESLA COIL GENERATOR

Your magnetite particles produced by your brain are *paramagnetic*, so when you are within an applied directional magnetic field, the magnetite in your DNA turns *in the direction of the flow* of that magnetic energy which connects the two fields, and you experience an electrical shock, because you gave that energy somewhere to go because you were standing on Urth, which is a ground. That ground is where energy turns back from electromagnetic and into photonic (sonic) energy again.

Also keep in mind, that anytime negative ions have built up inside a crystal (excess anions) in sufficient enough numbers to create a breakdown of the air particles around you (enough of them are deficient in anions), *it creates a magnetic field* which allows energy to begin flowing through. And keep in mind that you are a living crystal, so your energetic ions speak to other grounded crystals, such as the knob on your door, because that too is a crystal. So by grounding that energy you experience that release, causing the spark as it transmutes back to standing ion energy. The cathode (electrode) is your finger when you reach for a door handle (ground) and see a spark arc cross between them when you are dissipating or bringing in energy.

You recall now that these are secondary emissions. It is this *extra* energy that was behind the development of the *photomultiplier vacuum* tube that changed the world I will soon be discussing called the **dynode**, or part of the real technology the Cold Fusion Energy Temple Network actually used.

There is also the fact that your blood is *92% water* that is also *paramagnetic*, which then combines all of that energy with the energy generated by your bio-organic magnetite, exponentially magnifying your magnetic field around your entire body 100,000 times higher than the electrical pulse in your physical body. This makes your body *reactive to a superconductor*, able to suspend gravity when in the presence of a Meissner Field.

I have now shown you multiple different ways a Meissner Field can be generated, from super-cooled superconductors, Orme, and both piezoelectric and also sonic-powered Saser beams, so science cannot say this is not something that actually exists, or that your paramagnetic field doesn't exist, or that magnetic fields when in the presence of superconductivity don't create a zero-point, antigravitational field that suspends the laws of electromagnetic physics.

HUMAN LEVITATION

Any time you hear Secret Space Program whistleblowers talk about break away civilizations who are living (hiding) inside Urth (which have always been there for many thousands of years and in great multitude as well as in hundreds of civilizations and dozens of different species), they always mention a unique pendant that is *always* crystal

TESLA COIL GENERATOR

around their necks. If that pendant just so happens to carry the right mineral contents, sonically connected (harmonized with) to their body's unique frequency resonance (remember, this frequency is measurable with a spectrometer), then with a mere thought, they would have the power to levitate and even translocate to where they wish to be.

This is not magic or pseudoscience, rather established through countless experiments where superconductivity is produced through the power of magnetic interaction with crystal valences containing the right level of "proton holes". Inside magnetite, as has already been shown to be the world's most powerful quantum geometric signature to bring in and store vast amounts of anion ion energy, lies the essence of aether. This can no longer be ignored by science, the electrical industry or medical community. It is science fact. Lester's house didn't just magically fill itself with megawatts of electrical energy, nor did he have it hooked up to a massive electric generator. It was merely in the shape of a magnetite crystal which made it the quantum of "energy" itself.

And while science likes to act like there are magnetic fields, then there are more subtle fields that are not "magnetic", such as the "weak field" surrounding a crystal, what it really comes down to is every single field known to man is factually a magnetic field, whether it is electrostatic, electromagnetic or scalar. There is no such thing as a field that is not a magnetic field, so let's get our terminologies clear. This is because science has adopted the term

Cheops SPOKE Pt 2

magnetic field in replacement of the term **electro**-magnetic field as if they are utterly synonymous. They aren't. One is a Dark Matter magnetic field, the other is an electrostatic magnetic field that just so happens to be at its strongest signature using magnetite, neodymium or Samarium. Electrostatic magnetic fields in equal magnitude turn OFF electromagnetic fields. Thus, to them, a magnetic field really does mean electromagnetic, since they have chosen to go down the Dark Matter road at the total oblivion of "the weak force", as they have been duped into believing the strong force is somehow stronger than the crystal force I have already shown you is 3500 times more powerful when we looked into neutrino leptons.

The power of crystals can also not be ignored or simply brushed aside, since every solid state electrical device on this planet is made out of crystals. Every battery, every diode, electrode, capacitor, hard drive and processor has at least one quartz crystal inside. Usually many more than just one.

Superconductors are the quantum essence of the type of crystal valence that is "ash", or "host" to incoming energy. But since magnetite has both active outgoing and incoming ion flux, it "locks" with the ash's depleted state, triggering the mechanics of creating a vortex where the active cations and anions in the magnetite do not readily rush into the "holes" of the superconductor, but instead become one with it, with a zero-point field between, identical to how an electron continuously encircles the "ash" (neutral) nucleus

TESLA COIL GENERATOR

of an atom without ever “banging into” the quarks at its core.

Superconductor technicians aren't the only ones who have been using this technology. As pointed out in previous volumes of this handbook, Criss Angel will not be levitating right before your eyes anytime soon without his pendant around his neck. And yes, this is an open invitation for him to drop me an email and arrange a time where we can schedule a levitation so he can prove me wrong because the science doesn't lie. That email will not be forthcoming. Here's a picture of that pendant. Notice anything about it based on what we have already covered in the science of what ash actually is?:

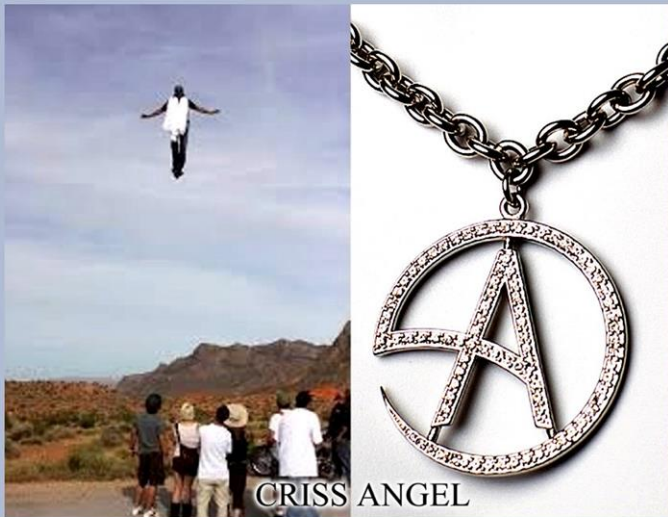

Cheops SPOKE Pt 2

In this pendant you are looking at dozens of small stones clamped hard in what appears to be silver. In actuality, that would be a mixture of diamonds in the center letter surrounded by dozens of quartz crystals clamped in aircraft aluminum or white gold. Both white gold and aircraft aluminum are made with magnesium. You recall now that magnesium produces the ultrasonic signature of photosynthesis, which would charge those crystals both night and day. While outdoors in direct sunlight, they would become stronger even yet.

As you recall now, diamond at its quantum atomic structure is identical to ash, similar to Black Basalt which is in fact entirely ash and magnetite combined. And like you, he grows magnetite inside his own body, which allows him to “network covalently bond” to those forces through *sympathetic harmonic resonance*. Perhaps you might also understand now why there is a pyramid in the middle of his pendant, or the geometric shape of magnetite calling out to the highest volume of energy delivered by the aether.

The high priests of the Israelites in Jesus’ time had a special connection to the aetheric or divine realm, and by a very strange coincidence, just so happened to wear a special breast plate on their chests, commanded by YHWH all such priests have while administering to god (doing his bidding). As you can see below, it was made up entirely of precious stones, each one having a different mineral ultrasonic signature. Sounds that cannot be heard, but

TESLA COIL GENERATOR

factually emit power we can now track using spectroscopic and photoelectric instruments.

The special powers that the priests' chest apparatus gave them were a fiercely guarded secret that came from ancient times from extensive alchemical Hermetic Occult knowledge of minerals. After learning as much as you now know about piezoelectric sonic and ultrasonic Saser waves, it would be more than just quixotic to imagine they were merely there for decoration; especially when they were *required* adornment. Sonically-speaking, the bells they were also required to wear around the bottom of their robes would also have made a very precise tone, emitting *pulsing square scalar waves* that would have had a triangulation affect from his breastplate along with the two piezoelectric onyx stones he was also required to wear on his shoulders:

Cheops SPOKE Pt 2

The Golden Garments (8th) of the Kohen Gadol Shemot 28:4-42

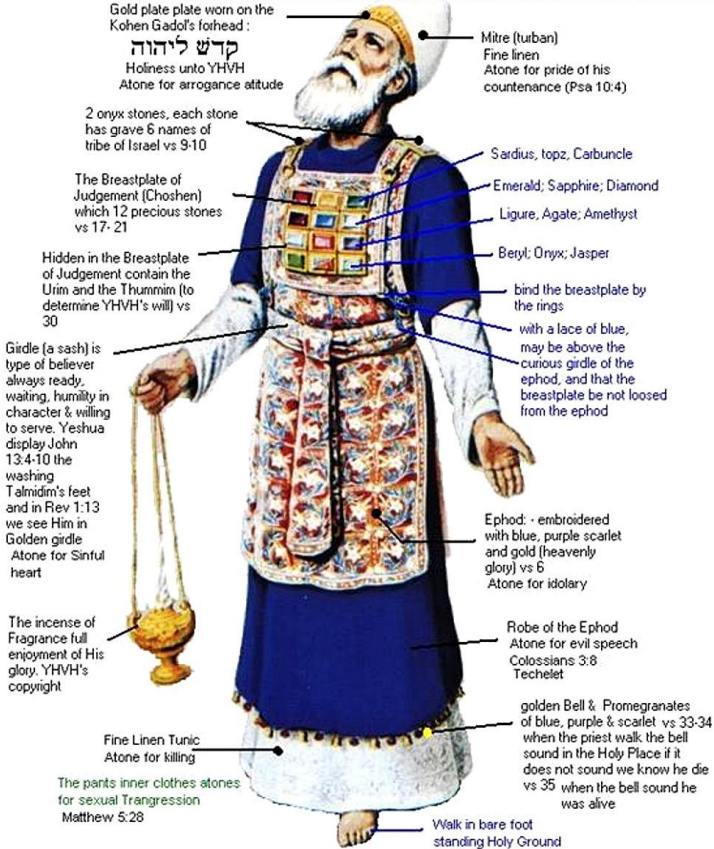

The stones were strictly dictated that this breastplate be adorned with, which you can see are varied. Let's take a scientific look at them shall we?:

1. Sardius: **Piezoelectric quartz**
2. Topaz: **Piezoelectric quartz**
3. Carbuncle: **Magnetic Garnet Nesosilicate**. Said to be "equated to the sun" by 33rd Degree Freemason Manly P. Hall in his Occult book *The Secret*

TESLA COIL GENERATOR

Teachings Of All The Ages. Really. I suppose that's why one of the main minerals in this stone is *Magnesium*. Mother crystal: **Bismuth**

4. Emerald: A Cyclosilicate. Contains Chromium and Vanadium. Mother crystal: **Bismuth**
5. Sapphire: Contains Aluminum, Titanium, Chromium and Iron. Mother crystal: **Bismuth**
6. Diamond: Same atomic makeup of **ash**, graphite and graphene. Mother crystal: **Bismuth**
7. Ligure: Another name for Lapis Lazuli, the **flagship stone** of ancient Sumer-Ur. Mother crystal: **Bismuth**
8. Agate: **Piezoelectric quartz**
9. Amethyst: **Piezoelectric quartz**
10. Beryl: Form of Emerald Cyclosilicate. Contains Beryllium and Aluminum. Mother crystal: **Bismuth**
11. Onyx: **Piezoelectric quartz**
12. Jasper: **Piezoelectric quartz**

The breastplate itself was specifically ordered by “god” to be made out of linen and wool. Wool just so happens to be the organic equivalent of **optical fiber** that works to connect crystals through dielectric permittivity as we covered in Lester’s brush with death story above.

Cheops SPOKE Pt 2

Bismuth is 52% sulfur. I don't have to remind you that sulfur is synonymous with graphite, graphene and ash. That makes all the elements above under the Bismuth mother crystal as well as the diamond synonymous with *black hole* in dielectric-speak, or the quantum of a *superconductor*, while the other 48% of Bismuth has also been shown to be the most powerful dielectric piezoelectric substance on the planet that at their core valence structures of **2**, **8** and **18** all vibrate within the harmonic resonance of 430-480Hz of the sun to activate pure anion ions through photosynthesis. Also well-known is the fact that diamonds are also superconductors as shown in wide-spread scientific reports. They are also atomically identical to graphene already mentioned which is what is used as the conductor of photoelectricity, the very essence of what has the ability to create a Meissner Field:

Diamond: Dielectric permittivity;

*“CVD diamond exhibits remarkable dielectric properties including a low dielectric constant of 5.7, a loss tangent below 0.00005 at 145GHz and a high dielectric strength of 1 000 000 V/cm. In combination with the extremely high thermal conductivity, low thermal expansion coefficient and high mechanical strength CVD diamond is an **ideal** dielectric window material. In particular for high-power microwave tubes (Gyrotron) with power levels exceeding 1 MW edge cooled diamond windows have found tremendous interest.”*

What are the chances that by mere coincidence alone, the 12 stones on this royal breastplate would be made up of

TESLA COIL GENERATOR

11 of the most piezoelectric substances known to mankind, with the remaining 1 known as the actual quantum of the term superconductor as well as the quantum essence of a photocathode? That out of those 11, one just so happens to be naturally magnetic and 5 happen to be self-powered Bismuth superconductors as well? Out of the 3,800 known minerals to choose from, these are the random 12? *Really?*

This may not mean much to you right at this moment, but once we get to the section on what a photocathode really is, you might want to revisit this to see just how precisely engineered this motherboard really was.

In addition to these, notice that he is required to walk bare foot since he is on “holy ground”. Actually, he would have been relying on his body’s dielectric sympathetic resonant connection to Urth’s cation-state as the repulsion device. Bare feet would have offered the *strongest possible* dielectric “window” wireless conductivity.

Little known is the fact that the Catholic Church was officially established as the “new” **Church of Rome** by **Roman Emperor** Theodosius I in the edict **De fide Catolica** in 380, but had already been announced by **Ignatius of Antioch**, successor of **Saint Peter**, in 110 A.D. Until that time, the same church was simply **Mos Maiorum**, or the *religion of the ancestors*. This has been clearly established as the worship of the Greek gods adopted when Rome absorbed that nation that had been

Cheops SPOKE Pt 2

handed down from Babylon, known originally as **Mystery, Babylon the Great**. Also clearly establishing that the “Israelites” were formally worshipping the gods of Babylon during Jesus’ time which were the exact same gods worshipped by the “Hebrews” who originated in Sumer-Ur, Babylon. That would be the collective known as the ***Pantheon SUNS of Ba’al***.

Since there are too many direct examples to even get into here to solidly establish this fact, I will allow you to do your own research on this for now. But the Occult gods of the ancient Hebrews while still in Sumer-Ur were the same as the ones the Church of Rome worships today, meaning the high priests in Roman times were in fact the same high priests now venerated as “saints” in the long history of the Mystery Religion.

Not surprising is the fact that not only did Saint Peter levitate when he walked on water with “Jesus”, but he also wore the very same breastplate pictured above while doing so, as he was a Kohanim priest, just like John the Baptist who baptized Jesus. This is not a secret. The Kohanim were the designated leaders of the elect in Babylon and they were the leaders of the elect in Jesus’ time. Since all Kohanim were required to wear that attire at all times while in service of the “lord”, this is a given fact he would have been wearing the motherboard while joining Jesus across the water, and so would Jesus, since he too was a Kohanim, having direct royal blood lineage to King David who was the penultimate king of the Melchizedek priestly class of the Kohanim Saints. Surprise.

TESLA COIL GENERATOR

One look into actual history proves the breastplate was designed by the Sumerians who tricked the very same Lulus throughout recorded time (not that they are dorks) with 1.2 billion still following them today, simply changing their name from *Mystery*, *Babylon The Great* in Sumerian times to *Pantheon* in Greece to *Mos Maiorum* in Rome then finally to the *Catholic Church*.

VIRGIN MIRI

*The Sumerian virgin mother still remains the Leviathan lineage's ultimate reverence even today. The **virgin Lili** (Lilith) gave birth to the sun of god **baby Atum** (Thoth/Adam) 250,000 years ago, the **virgin Isis** gave birth to the son of god **baby Horus** almost 5000 years ago, then miraculously (hey, these are all miracles we are talking about here) **Miri** (not Mary) of Nazareth did the exact same thing with the son of god **baby Jesus** 2000 years ago! Amazing! Just as amazing is the fact that each virgin mother's name were all spelled with two Is (as in IsIs)! Little wonder, since that's her own personal symbol (Command Signet).*

“Immaculate conception” is just another word for in vivo, or placing a fertilized egg inside of a host womb, which was absolutely needed for a brand-

Cheops SPOKE Pt 2

*new reptilian/human hybrid creation, as it was for each upgrade the new species received down through the ages as that race became more and more human-looking. Lili, Miri and Isis are just other dialects for the ancient name Wawwu, all of which are also known as **Hathor Miri**, the **mother goddess** and queen of the ancient city of **Mari (Miri)**, **Babylon** where plumbing and the wheel were “invented”. In each case the new child would always then be suckled by the participating host mother:*



Virgin Wawwu and Thoth
250,000 B.C.



Virgin Isis and Horus
ca. 2686 - 2181 B.C.



Virgin Mary and Jesus
1365

*Miri comes from Hariri (also two Is), which is the current Turkish name for the **city of Mari (Miri)**, **Syria (Babylon)** as translated into English which translates into the word silken, as in the soft mother's breast. Which is why the virgin mother is always shown breast feeding.*

TESLA COIL GENERATOR

*The word **ab** used for mother's milk in ancient Mesopotamian was equated to semen, amnio fluid and also to water in ancient Sumer-Ur. In higher dimension amneo fluid (liquid crystal) is equated to water and air and is the "liquid of life". Which means that Mother Mary/Miri literally means Mother's Milk or Mother's Water of Life.*

*All such references to the highest mother goddess will always include a living female that was used in the production of the new Lulu species, but will always also refer explicitly to **Enki**, the androgynous mother and father of their races. This is why there are two Is. You've already learned that deity titles were reversed at the time the Leviathans exited the Co-Evolution BioRegenesiis Treaty. The second I refers to Enki, the first one to the actual surrogate who carried the new model.*

*A simpler way to say **Mother Mary** is the **Virgin Wet Nurse**.*

HUMAN LEVITATION CONT.

And also not very surprising is the fact that 20 Catholic Church saints have been deified for levitating while giving

Cheops SPOKE Pt 2

the weekly sermon. It was common in earlier times to portray priests hovering above the ground during services. Sans the breastplate of course, since that is well known in our times to be a “Hebrew thing” today, thus those paintings that do depict the plate are held back in private collections to hide the fact that Babylonian Hebrews and Roman Israelites were really just the same people who are now called Catholics which were then and are today, just different versions of Lulu hybrids along with their human converting mates:



All humans need to do in order to levitate is create an electrostatic magnetic field around themselves that would be tuned to their resonant signature and therefore, directly to their thought-waves to activate the wave, just as Peter did when he walked out to meet Jesus. His feet would ground to the cation ions of the water the moment he began levitating through quantum locking to his already determined altitude and the water would then appear to

TESLA COIL GENERATOR

somehow have become a solid surface below him. The more energy within his field, the more air would function like a ground, since air is also just thin water.

By wearing powerful photoelectric crystals on your body to superpower your own magnetic field, or by adding additional magnetic influence to that field, as long as you are standing over the opposing force of the Urth's cation ion "ash" crust, you absolutely do have the power to levitate. But there is a delicate balance to this precise signature that must be struck. Without knowing what produces the exact harmonic frequency, you may as well be a million miles away from that equation. Until the first crystal radio was invented in 1894 by Jagadish Chandra Bose, man had spent thousands of years without one. Since that time you can purchase one for as little as a dollar today. What is "impossible" now is merely technology lost during the last population recycle.

In what was pretty obviously not a rehearsed or scripted visit to a Buddhist Monk in Nepal that *Dan White* had traveled a very long distance to meet with in person, the Monk walked in a circle first, excited the field around him within a few moments of concentration, uttered two sonic sounds after he sat down and levitated:

Cheops SPOKE Pt 2



Do I think this Monk is wearing any crystals? I doubt it. A true Shaman is from the seeding of 24 to 40 strand DNA Awareness into this population as a “human” to guide the two new Avatar projects on-planet who have finished with their long-cycle of evolution into the next level of the game.

While actual humans possess an average of 73 millivolts of static electricity (produced by the spark of their thoughts), shaman have been shown to possess as much as 200 volts, or, 27,000 times as much energy. This is simply because Oraphim genetic frequency spins at a much higher rate than humans do. This allows our awareness to rise above much of the “white noise” that cancels out the processing power of our reptilian brains, assisting us in our jobs to bring you answers to the hidden clues humanity has been saddled

TESLA COIL GENERATOR

with. This Shaman/Monk is more than likely simply using his own magnetic field assisted by the fact that he has already **broken down the air** around him with the candle flames, allowing his “magnet” to interact with Urth’s supercomputer body.

Remember, energy is oxygen. Oxygen is used up by open flame. In the presence of oxygen-depleted cation ions, the dielectric reluctance in the air is broken down to allow a direct path to “connect” to another crystal over a distance (not being squeezed together under heavy pressure). Since the shaman is generating a magnetic field, not just a vastly-weaker electrostatic field, his symbiotic magnetic “stasis” doesn’t cast a spark between the two points, it triggers a Meissner Effect.

The air surrounding this Monk can be thought of as “ash” in very real terms, equating it directly to what is known as a photocathode we are still getting to. This is the stepping-off point between two dielectric fields you see in every magnetron, synchrotron and cyclotron on-planet. The “two sonic sounds” the Monk had uttered has everything to do with how he **set into motion** the Meissner Field which will become more than clear to you once we investigate the true technology of how Cheops performed the way he did in ancient times. It is the real secret behind the magic, as it offers the path for one resonant field to reach the other.

Cheops SPOKE Pt 2

This is nothing new. Monks and Shaman have been levitating before the eyes of their tribes, visitors and in front of documentary crews around the world for decades; even during the times we've had such technology to record such events. And of course, the legends live on down through time previous to today, where you can watch videos taken by friends with smartphones and on documentaries online that show repeatedly the holy man **walking in a circle** around a fire or inside a ring of candles (or just in a semicircle such as seen in the video this still was captured from), then levitating. There are no strings, lifts or platforms of any kind as shown by careful examination by the cameramen, passers-by or crew. Of course, the same places where these holy men are from have the stories passed on from their parents and grandparents of holy men doing the same thing for centuries. Why do they always walk, dance or move in a circle first?

In the most recent wave of men walking on water, levitating, walking vertically up the sides of buildings with their body perpendicular to the vertical structure, we see one street magician after another perform such feats in broad daylight, surrounded by hundreds of onlookers on their way to and from work. You can claim these are hoaxes, but the onlookers never report any wires, booms, helicopters, or any other aids, simply because there are no aids other than the crystals that they are wearing (given they aren't actually Indigos), placing them inside a Meissner field.

TESLA COIL GENERATOR

The human body creates an ionic magnetic field, and certain crystals on that person amplifies this energy signature at the precise frequency of oscillation rate required to come into sympathetic harmonic “phase” with the superconductor of Urth. Knowing the right combination of crystals that will harmonize with your body is the only thing missing from the equation. The paramagnetic magnetite is already there, just as the energy from the piezoelectric calcium that makes up every bone, hair, fingernail and even the skin of your body that locks in the field around you through network covalent bonding.

The fire or burning candles around you removes the oxygen from the air as just discussed, offering a *permissive path* for dielectric connection. By walking or dancing in a *clockwise* concentric pattern, you are forcing all the standing cation ions in the air into a **cyclonic vortex** that now travels in the “up” direction in terms of energetic flow, meaning the lighter of the two opposing forces will now move in that direction away from the other in order to create a zero-point zone between the two. Now all you need do is *sonically produce a concussion wave* in the air with your mouth (or other device) to connect your energy field to Urth’s in order to complete the Meissner Field. It is the concussion wave that is the final turning of the ignition-key as it were that causes all of your energy to travel through the air so that it can reach the opposing force.

When Shaman/medicine men perform a rain dance, what are they doing? They are traveling in a clockwise concentric pattern, stomping their feet, chanting in rhythm

Cheops SPOKE Pt 2

and always have drums carrying that sonic wave around that field that is always around a fire. Suddenly it rains. Why? They are literally sending their heart-beat's intent UP into the clouds where the clouds are able to hear them they want rain. It is merely a matter of putting the scientific mechanics into place that helps man communicate with the aether. The "weak force" isn't so much weak as it is tuned to a totally different set of electrical commands than you are used to.

As merely an aside, in case you were planning on attempting this yourself, I cannot stress enough that you have to believe that you will levitate in order for you to cast this reality. If you have even a single percent of reservation, the aether will not produce the event for you. When you were told a million times to "believe in god", what they really meant was to believe in the aether. Without that, this type of action absolutely will not work unless the forces around you are simply too high for your doubt to overcome.

ULTRASONIC LEVITATION IN ANCIENT TIMES

Himalayan or Tibetan singing bowls from the times when monolithic structures were still being repaired would have been pilfered immediately from construction sites even at the time of ending the rebuild, as they had immediate use in any home as a fully functioning utensil. But in reality, they

TESLA COIL GENERATOR

were used to create precise tones, coupled with Wizard Hats that Michael Tellinger calls “bell stone cones” which would *sing* giant stones from the mine to the processing plant, or into place within a structure.

Each bowl would generate the sonic tones for each general size object it would work with, and each wizard stone would be tuned to that range as well. I would assume that smaller stones and smaller singing bowls were paired for small jobs, and larger, deeper-tone bowls would be paired to the very large Wizard Hats that Tellinger has found, were used to move larger objects:



Wizard Hats, or the cones you see above top right, are depicted in ancient reliefs held by the gods as appearing as pine cones, but each one has clear cuneiform text inscribed indicating the range of stone sizes they were tuned to, and sometimes with the actual job-site they had been used on when it had significance, such as building a palace for the Pharaoh.

They were used like *Saser Beam Ultrasonic Lasers* are used today, where levitation was achieved through

TESLA COIL GENERATOR

triangulation of the tones mentioned in previous chapters of DTH. What isn't known about the stones that Tellingier is finding all over South Africa around the millions of stone circles covered in previous volumes of the handbook, is that *Sonorous rock* or *bell rock*, is actually the precise type of stone used in the *Space Telegraphy patent # US767977A* for receiving signals originating outside this atmosphere. This stone is so highly receptive to incoming magnetic waves, that a tiny fleck can pick up radio signals from other solar systems. And it just so happens to be, out of the thousands of species of rock on Urth, the one stone used throughout this now massive collection of cone tools found consistently at stone circle after stone circle.

The Sonorous rock is used in music devices and in general, sonic applications where the ability to transmit and broadcast a precise signal from an electrostatic piezoelectric source allows its use in technologies in virtually every high tech field today. Again, just like the precise stones used in the building of Cheops and the global energy grid are not random in any way, other than to the naked eye.

The bowl would generate the electrostatic sonic wave torus energy field then two Wizard Hats would finish the 3-way triangulation by amplifying the waves to the size stone that contained magnetite they were tuned to, each being held by hand. The Wizard Hat stones are sonically tuned to the sound being produced by the bowl, acting then as *resonant inductive couplers* we will be covering deeper as we go. The stone could then be lifted up and moved into place

Cheops SPOKE Pt 2

because it was now inside a zero-point Meissner Effect field. You would simply rotate the wand around the lip, not unlike making wine glasses resonate, until the block levitated and throughout the positioning process. Though not in the same concentration as Black Basalt, the granite megaliths used in original construction of the Great Pyramid has naturally occurring magnetite throughout.

Levitation was necessary when large stones already formed needed to be set back in place during Cheops' rebuild, or when they harvested a new block with a particular mineral composition that needed to be placed somewhere specific within the structure where they weren't able to simply pour it there. However, most of the rebuild took place from liquid granite formation as I have already demonstrated. Some stones may have needed to have their crystal lattice structures aligned at all times like only a sedimentary stone cooled over thousands or millions of years, requiring that block or box to be quarried rather than formed, making sonic levitation critical to the construction.

TORUS STONE TRIANGULATION LEVITATION

The stones that make up the *stone circles* in South Africa where the pinecone-shaped Wizard Hats are found, are also made out of the same type of *Sonorous bell stone* that resonates just like a tuning fork. It has been found that these circles process Urth piezoelectric signals from below,

TESLA COIL GENERATOR

then combine their own energy to that, producing over **375 GHz** wave fields:



To give you an idea of how high 375 GHz is in terms of phonon energy, an ultrasonic frequency Saser ballistic sound laser begins at a standing level of 9.3 GHz, and with the amplification crystal that is applied, such as a ruby, increases that an additional 23.3 GHz. From there, through the process of collecting secondary emission ions in the peak wave, it is able to generate more than 1600 GHz from less than a beginning 33 GHz. The *standing* energy of these stone circles is almost 10 times higher than that. So the energy that is simply radiating from these circles prior to any amplification is, in a word, flabbergasting. Tellingner reports these wave fields shut down sensitive devices such

Cheops SPOKE Pt 2

as GPS and cell signals completely, merely by placing them inside that circle.

Over 10 million stone circles have now been identified by Tellinger that he has been studying in South Africa for more than 10 years, learning there are literally millions of “gold mines” in this one region. Apparently this was where the highest concentration of gold was seismically located on Urth when the Anunnaki began mining noble metals for the production of Orme a few million years ago. I place quotes around “gold mines” because they weren’t searching for gold, they were searching for all the noble metals produced by the mother-seed crystal Bismuth that yields all such monoatomic minerals. Natural gold is often found in a perfect octahedron (square pyramids on both ends):



TESLA COIL GENERATOR

As already covered, the four planar sides of a square pyramid shape forming the peak of a crystal with an equilateral square base is the **Cellular Language geometric shape** that signals that element as the material receiving the highest level of magnetic static electricity from the aether that Lester was toying with when he learned that any material will gather and store this incredible level of energy when it is “open ended”, meaning that the shape is one half of one whole of a completely balanced resonant field. The noble metal of gold above is called a *hydrophobe* when two square pyramids connect in the center in this octahedron shape, as it utterly repels water, just like oil. In real terms, that “double diamond” shape is a “perfect sphere” in quantum translation how amneo (water) responds to that geometry.

This ultra-non-conductive shape is used in nanotechnology to enhance photoreceptivity, or to magnify the slightest bit of photonic light, used to make **Terabyte hard drives**. An entire industry has formed around this one shape alone as a *cationic surfactant* (which makes water bead on a surface, forming **perfect optical spheres** in the smallest moisture for optimum refraction).

You already know by now what a cation is, an “empty sponge” to the oxygen known as electricity. Synthesized versions of cations are known as *porous mono aniline* or *polyaniline crystals*. A cationic surfactant would make all 8 sides of this precise shape a quintessential form of ash in ionic-speak. And as we have already seen, this is the exact same shape that wood takes when it goes through a fire and

is reduced down to its smallest particle size. The Nanomaterials Industry uses this shape in very specific terms in order to synthesize the very quantum essence of what we call graphite or graphene that carries the greatest resistance against Dark Matter energy current and produces perfectly shaped optical spheres for projection technology.

Gold in this form both in nature and in nanotech is known as “the gold standard” in *surface plasmon resonance* (SPR) which is directional refraction. Light is sound, so SPR can be directly equated to ultrasonic applications. Energy is also sound, so the microscopic minerals (gold, magnetite, iron) in these mines refracted the most piezoelectricity on a quantum level, rendering the highest ultrasonic energy signals from the Urth itself that the Sumerians were working with:

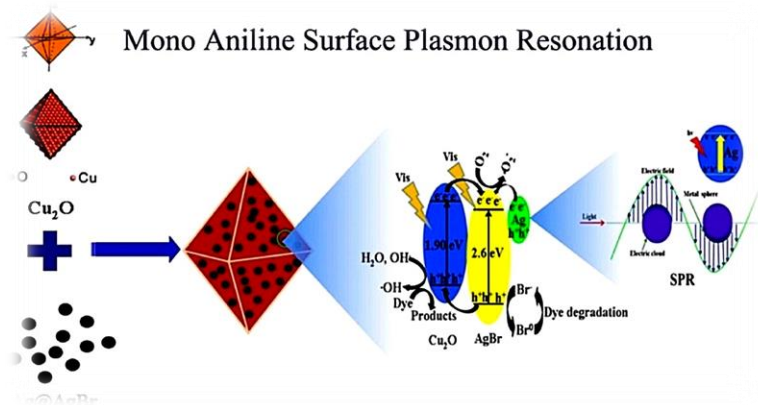

It is accepted in the nanotech industry that the **Aniline particle shape** offers both sides of magnetic attraction and

TESLA COIL GENERATOR

repulsion, meaning that it can drink in the most energy (the top half square pyramid of the octahedron) and readily release it (bottom square pyramid) in ion-energy exchange. In the Lithium-Ion battery, Aniline crystals are king at transferring optically-precise photoelectric signatures for optimum surface plasmon resonance. Which means they carry optimum energy while at the same time are already in sympathetic harmonic resonance to the opposite square pyramid to release that energy.

You can think of the Aniline crystal as a battery with both a positive and negative end, where the single square pyramid is working in a closed loop where it doesn't want to hand out its energy, rather retaining it and using that as the permanent magnet that forever attracts iron or repulses other like-type magnets. Remember, magnetite kills electromagnetic fields and enhances electrostatic fields.

Polyaniline crystals:

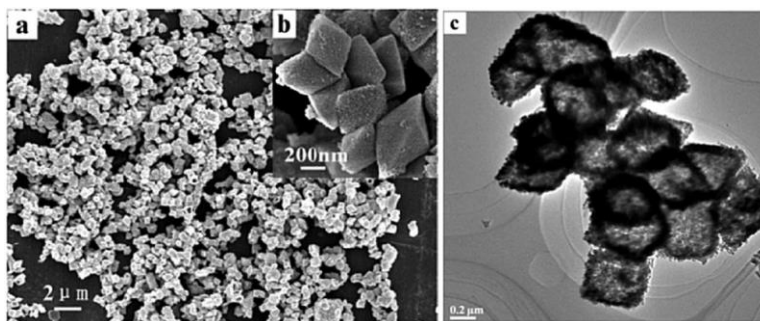

ANILINE CRYSTAL REVEALED

Here is an electron scanning microscopy of an actual organic Aniline crystal. It has been hidden under hundreds of scientific names such as Lithium, Behenyl Acrylate, Dilithium Oxide, Li_2O , Docosyl Acrylate and on the list goes what seems forever, each one as ferociously concealed to its origin as the next. It took untold searches over almost 3 years of research to find it, since it is the most hidden secret within science. This is the medium of energy itself known as Deuterium covered in exhaustive length in previous chapters.

One look below, and you may be able to understand why it was that Rome's letter I for Lambda, which stands for OX in ancient Sumerian, short for OXYGEN, not a male bull (which is a huge report all in itself), looks like this: Λ . This is the reason the second I in Isis, Miri, Lilith, etc. stands for the father/mother god(dess). All of particle science, all of electrical science, quantum science and mathematical science revolves around this symbol because it stands for the power that makes manifestation possible. **It is also the reason why there is always a silent letter a in the correct spelling of aether:**

TESLA COIL GENERATOR

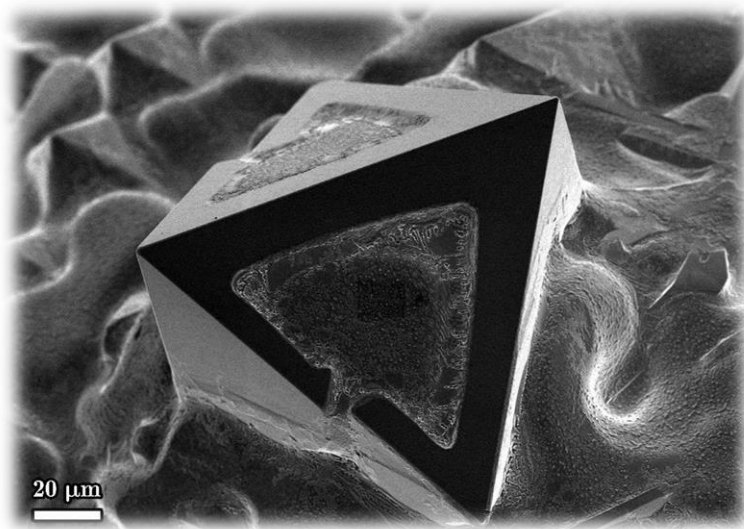

Referred to as a “*Deuterated Reagent*”, this tiny crystal is “ported” on all four corners at the separation point between the double square pyramids, which are the horizontal meridians that dictate its ready flux to bring in and dispense energy while maintaining flawless “hydrophobia”. Aniline is *aether itself*, though it is in crystalline form and is sold in what else? A liquid aptly named **Ether**. It sits at the center of a single microscopic bead of water that forms into the perfect optical lens to project light in every direction. Besides thousands of everyday products based on Aniline, one of its most universal uses is that as an anti-electromagnetic charge for building computer processors, painted on the floors and woven into “antistatic” fabrics to protect the other Aniline crystals at the core of every computer and smartphone from overloading.

Cheops SPOKE Pt 2

The **depleted version** of this crystal, known as ash, is synonymous with **cations**, known as a **quantum black hole** or “vortex” where energy is literally sucked away from anything around it, then broadcast back out as long as water is nowhere to be found to offer it insulation once again. That is the quantum essence of the alien crystal Bismuth as we have already covered. The Sumerians knew about this crystal and based their entire mining operation off of the power it held to bring energy up through from Urth’s core, then broadcast it into the atmosphere to power their crystal machines.

Each **Geometric Ion Vortex Stone Circle** was formed to mimic the exact shape and layout of where Urth’s energies (in science, called *Planck’s Frequency*), come up through the surface in that precise geographic location through unique deposits of piezoelectric, *surface plasmon resonance* stones below as refracted and deflected through the various geological formations below ground, this is why each stone circle is different from the other, just like a fingerprint, but *always* concentric.

TESLA COIL GENERATOR



The mere fact that these ancient miners knew what patterns the waves cymatically took in these areas prove that modern man today did not invent Kirlian spectrography, Cymascope or Cymatiscope. They could see the waves emanating from the ground on their more-than-likely pure crystal video screens, and simply placed supercharging broadcast bell stones along those concentric outlines. Computers have been around for trillions of years in case you were thinking they were simply winging this all by the seat of their pants:

Cheops SPOKE Pt 2



Here is a 250 million yr-old microchip encased in sedimentary stone in case this is difficult to understand:

TESLA COIL GENERATOR

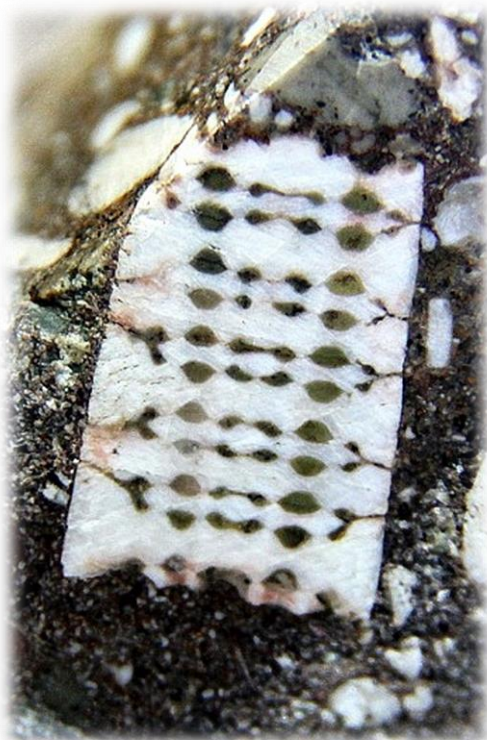

The always-concentric patterns of the stone circles were each built without any openings through the stone walls, meaning they were not used as cattle or horse stalls, grain storage or for any other industrial application other than the production of standing Saser ion wave fields.

Astonishingly, they were all connected to each other in massive grids that would span miles in all directions with a continuous row of piezoelectric Sonorous rocks from each circle to the next, combining their energies through *network covalent bonding* (explained in a bit):

Cheops SPOKE Pt 2



We've talked about bell stones many times in the pages of the first volumes of this handbook series, so you know we are talking about extremely unique stone here that is known for its application of the Glass Armonica, an instrument that produced very powerful, emotional responses from those who heard its music, invented by 33rd degree Freemason, Royal British double agent spy and perhaps America's greatest traitor, Benjamin Franklin. Effectively 37 lead-crystal wine glasses connected on a single shaft, like rubbing the edge of each one, produced haunting musical notes. Each one resonating exactly like a Tibetan Singing bowl used for thousands of years to levitate megalithic stones. Musicians who played the Armonica quickly went mad.

This is because the glass bowls used in the Armonica were made with **Bismuth Telluride**. The white powder produced from the Tellurium crystal that comes from the mother crystal Bismuth which is well known to cause tellurium

TESLA COIL GENERATOR

poisoning. Telluride is also known as having the quantum atomic structure of sulfur ash and is found predominantly in Sonorous rocks.

The stones stacked along the lines of each of the millions of energy vortex fields across Africa apply pressure to each lower row, which only intensifies the required compression needed to activate their natural piezoelectric energies of these *highly paramagnetic* stones, which explains why each circle is so powerfully energized. This precise species of stone just so happens to each one carry its own *magnetic field* and when combined to another, that field grows exponentially stronger through secondary emissions. The more stones, the stronger the electrostatic magnetic field.

Of the three unique types of stones that make up the Great Pyramid, the most compelling one of particular significance is Basalt as we have already covered. Its use in the construction of the multiple stone boxes inside Cheops which are actually *resonant inductive couplers* and very specifically, the capstone, are not just minor details because Black Basalt, as other Basalts, just so happen to be Sonorous, singing stones. Just like the Basalt stones making up the stone circles of Africa. Like modern trees, there are many flavors to Basalt, which is from the geological *diabase* genus, also known as **dolerite**, which apparently are code words for *4th Dimension Tara silica tree fiber*. Here are a few Basalt diabase stumps:

Cheops SPOKE Pt 2



TESLA COIL GENERATOR

There are miles and miles in China such as the Zhangjiajie National Forest (literally named forest) of diorite/dolerite/Basalt trees all wacked down at one time like a giant aerial lawn mower hovered overhead and harvested them like stalks of wheat:



What makes this “stone” so unique is the fact that Sonorous Basalt stone generally rings in the note of **B flat**, which stunningly just so happens to be the exact tone emitted by **black holes** as shown by LIGO Observatories when recording the signal produced by two black holes merging as shown here in this digital image as a B flat, 57 octaves below middle C:

Cheops SPOKE Pt 2

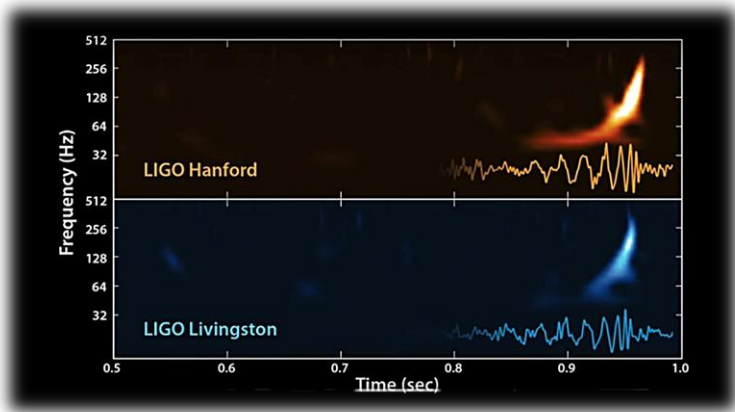

But why would this precise note be so significant along with the fact that it is the same note produced by black holes? Because the sonic frequency of B flat is the note (Command Signature) harmonically tuned to literally *suck* photons out of matter and transduce them into free (open air) sonic phonons (ions). They are a *living vortex field*. Modern trees today do this same thing, where they produce “oxygen” from the water and minerals they literally *suck* out of the ground and push upward against the laws of physics, and emit anion ions directly into the air. No different. And now you know why living plants are able to defy gravity while elevating water above ground. It is the frequency that the living plant resonates at. The atmosphere of 3rd Dimension Urth works on carbon silica which relies on water to transport free ions, but in 4th Dimensional Tara, apparently their trees were so large they relied on the much stronger pure silica to hold the shape of their fibers. Today we use slivers of this material to do nearly everything in advanced technologies.

TESLA COIL GENERATOR

As the Basalt silica trees dissolve slowly into the Urth, the crystals then bond with minerals in the ground, forming composite “rock”, which is factually not a megalithic, single stone. Sonorous “bell stones” are not defined as stones at all, but rocks that have bonded together in atomic random crystal directions. This means simply that until they are placed under an applied magnetic field, they are not conductors of electrical energy. But once the field has been energized, such as when stacking them atop each other in neat, concentric lines around the geometric cymatic lines of each defined field emanating from Urth’s core, they are.

It is because “ash” Bismuth minerals rich in magnesium and shown to have the highest piezoelectric signature of all materials have melded with “ash” Basalt fibers rich in natural magnetite in this plagioclase feldspar that this particular mineral was used in all the critical photocathode points within the Command Temple.

Ancient Lulu miners would have to build a new power generator in each new mining area that would give them the power of levitation so they didn’t have to tote the stones being quarried by hand or cart. This was one part of the power system. The other part would be in the form of *levitation torus stones* shown below that Tellingner has also found in abundance at these same sites. As explained previously under TORUS FIELD, electrostatic magnetic energy when bound by a conductive (electrostatic permittive) ring is then “trapped” inside that ring, it forms

Cheops SPOKE Pt 2

an apple-shaped energy field around it, constantly circulating the free anion ions similar to an electron encircling each atom. As mentioned, magnetite-rich, piezoelectric stones carry power far higher than simple Dark Matter electromagnetic torus fields and require no moving parts to do so. These torus stones carry this pure-ion energy, but more than that, they also act like both broadcast receivers and antennae for *ionic conduction*.

Michael Tellinger has a favorite story that he passes along in each of his seminars since attempting to transport one of these torus stones via airline not long ago, delivering it for laboratory analysis. He had gone through customs when he was stopped by a group of armed security agents for the airport (aether portal). They demanded to inspect his bags as the plane sat on the runway, unable to depart until this matter had been resolved.

The agitated guards with weapons drawn explained to him that whatever was in his bag had just short-circuited the TSA homeland-security computer network in the building and whatever he had with him could be a serious threat to national security. He gladly opened his cases and unwrapped the carefully protected stone, explaining that it was just a rock he had picked up as a souvenir.

The agents didn't look any further in his luggage at that point, because they knew what they were looking at and were aware that the stone had generated such a powerful

TESLA COIL GENERATOR

electrostatic magnetic energy field that it crashed their network. This was *one single stone* not much larger than a bagel vs an entire airport. I am sure in the hopes that Michael had no idea that it was anything more than just a novel rock, they made no issue out of it and released him for travel. There was no need to inform him that he was carrying a solid-state photoelectric energy power plant.

Here are some ancient levitation torus stones:



*(I use the term **levitation** torus stones here; only because that is what application I am identifying them to serve in this paper. My contact has also explained that these torus stones also generated the energy that cut megalithic stones like a laser as well, but I haven't yet been briefed on how the laser was actually achieved. I will of course pass that*

Cheops SPOKE Pt 2

along to you the moment I learn about those tools, but in this case, I am just calling them levitation toruses.)

These stones could be carried by hand inside the mine, and would act as ionic resonant inductive couplers that would bring in the massive energy from the vortex stone circle outside the mine, capture it within the torus field, and then simply sit there and wait until two Wizard Hat stones were then placed in relative proximity to each other close by. The two cones would then begin harmonizing between themselves and the torus stone, and would reach a sympathetic resonant pitch (which if audible, would sound like breathing or a *woom woom* sound).

When they reached the precise resonant tone, they would then act like broadcast inductors, just as the torus stone, but then the sound would be precisely directed out of the sharp tip of the cones. This is known in electrostatic conversion as magnifying the phonon energy of the field down to a Saser point, like a massively-energized laser beam minus the visible photon light. The cones and torus stone would triangulate the block they were moving which would then be walked to the nearby Urth movers that would take them to the crushing plant where the gold and other raw monoatomic metals could be removed from unwanted content (called *bloom*).

This would just require two people; one holding the torus stone, the other directing the cones to hold the triangulation

TESLA COIL GENERATOR

of the torus field of the two additional points of the three-point broadcast field. One is always the standing energy (the torus stone), as shown below in the photo that would be the *center marked energy field*. The other two (Wizard Hats) send out the ultrasonic harmonic waves of the positive and the magnetic ends of the *paramagnetic* item being placed into the zero-point Meissner Field. Each cone would be pointed in the direction of one end of the stone to connect the *electric field* (outflowing), the other directed on the opposite end for the required *magnetic field* (incoming). This means they could lift stones of any size as long as they had an ample trace of magnetite inside:



If the simulated illustration above had been a male actor, the electric field would be on the right, at his head, and the magnetic field would be on the left, at the groin, because females are magnetic from their crown chakra, and males are magnetic at their pelvic floor chakra. A male and a female when combined complete the one synergetic full electrostatic magnetic torus field. They were designed, in

Cheops SPOKE Pt 2

the lab, to go together to become “one” complete energy field, as they are “like-kind” crystalline entities in polar opposition. The male is the anion ion, the female the cation.

So as you see, there is sonic levitation where the Wizard Hat rocks would be coupled to the sound generated by a singing bowl that generates its own oscillation energy field through *sonic* (audible to the human ear) amplification. Then there is electrostatic levitation where the same cone rocks would direct the energy from the torus field that would “channel” higher energies needed from the much larger energy device stone circle nearby through *ultrasonic* amplification (above audible spectrum). Two completely different forms of energetic levitation from each other from our perspective, but ultimately the cones both worked to use sound as the method to generate the *Meissner Effect* zero-point suspension field.

It is important to note that while the Wizard Hats are generally very ceramic-like, and the torus stones found are more of a granite composition, these are the same stones at their molecular core. The Sonorus stones, also known as *ringing stones*, weather quickly, unlike granite that is extremely hard and dense, making granite a relatively permanent stone with a half-life of 180 million years. When ringing stones weather, they break down into granite sand particles at its core. This is *monzonite*, or another word for *quartz crystal*. Both granite and Sonorous rock are the very unique type of stone that is paramagnetic. You recall now that paramagnetism means that when they are present within an *applied magnetic field*, only now do the Aniline

TESLA COIL GENERATOR

crystals inside their crystal lattice align, allowing the flow of energy, and only in the direction of the magnetic field's travel.

Now understand this; as we have already covered, a group of these paramagnetic stones and rocks that are normally not within an *applied* magnetic field sufficient to cause all their electrons to turn in one direction, can detect subtle energies from below, then amplify them between their group to now generate a magnetic field sufficient to activate their mass together as a single, now-conductive (or *inductive* in science-speak), unidirectional connection of their combined piezoelectric energies, creating a massive wave field as Tellingner has found while conducting magnetic field tests at these stone circles.

However, this intense energy field doesn't need to be in only the exact shape of Urth's energy signature at that one geolocation, it can be just a pile of Basalt rocks there as well, as you will soon see. Urth's resonance will shoot up through that mass, then the rocks themselves will choose exactly which ones within their grouping will then harmonize with the Saser signal Urth is sending to the surface, 100% of which is piezoelectricity. However, covering an entire huge area with these very precious stones is far more prohibitive than just following the geometric shape that the Saser wave is striking with stones placed directly along those wave lines.

Cheops SPOKE Pt 2

What the ultimate shape needs to be for any torus field, however, is relatively *concentric*. That might not be a perfect circle, but it must be at least a 3-point (or higher) field where they are grouped, allowing the torus “apple” flow of energy to envelope the group together. Keep this in mind for when I explain how Cheops goes about producing the power that once emitted from its capstone.

COGNITIVE DISSONANCE

While it seems like I am reiterating the same terms redundantly ad infinitum, it is significant for you to understand that the human mind rejects any new, foreign information the first six times it sees or hears that new detail. This is described in cognitive science under both confirmation bias, and the backfire effect. Only on the seventh time (or the rule of seven) do the mental receptors accept this information as something that is real, and only then does it actually retain that information.

I am not going into all the scientific details of that here, but welcome you to research this for yourself. Understand that unless I impart to you at least seven times each new thing I am trying to get across, if you haven't heard about it before now, you will never understand the significance of what I am trying to convey. These bell rocks, and torus stones, both quartz crystal, and both paramagnetic,

TESLA COIL GENERATOR

are the same exact things that make up the very key points within the pyramids, and are not to be confused with random stones from your creek bed. While we go about making our silicon chips smaller and smaller today to fit inside smartphones, your ancestors were scaling actual stones up to literally move mountains.

Until you believe that mountains can actually function as something other than a pile of debris, you will resist this new information. Hence, I am showing you the science behind multiple ways that levitation actually exists, not because the pyramid Temples levitate, but because the science of how levitation works has now been shown that the way this is accomplished is through the suspension of electromagnetic physics. And it is through this suspension that the pyramids are able to generate and multiply energies you are not yet familiar with.

SONOROUS ROCKS

There are many terms for Sonorous rocks, as you have already seen a handful of referenced here. But when they are found in a natural setting where they resonate together as a single field, perplexing scientists in coming to terms with their incredible power to sing or resonate out sounds in a highly unusual manner, such group of rocks are always found in a *natural cylindrical grouping* together; something

Cheops SPOKE Pt 2

called a *Pluton*. Of course you know by now that a Pluton is merely the one spot where an entire silica tree stump broke down over the eons and fell directly into a single heap.

While each of these rocks are inside that quarry heap, they carry an extraordinary ability to broadcast sound. When they are removed, taken home to study individually, much of that incredible nature is lost for no explainable reason. This is because their resonances all harmonize while in this circular shape together while applying even greater pressure than the required 0.1% for activating phonons to the rocks below, increasing higher sonic frequencies that now runs through the entire group through network covalent bonding. If you remove one of these rocks from that field, then it is going to revert back to its own reduced electrostatic magnetic energy signature.

Again, if you could hear this sonic signal, it would be a *woom woom* sound, or the sound of resonance such as harmonizing two strings of a guitar. A large group of Sonorous rocks found in Montana called ***Ringing Rocks Pluton*** is shown here from an aerial view:

TESLA COIL GENERATOR



And of course you already know that sound resonates within a cone at its optimum potential. Yet more specifically, it resonates from 4 juxtapositioned points we will get into further, creating a *square wave signal*. A cone can be used as a similar concentrating pattern, but will lose the secondary emissions generated by the sharp edges in the shape of a **square pyramid** as seen in the geometric planes of natural magnetite. In nature, the **field** emanating from a sine generates a **concentric wave** flowing away from it, hence the concentric shapes of the stone circles that are placed above the multiple square pyramid surface plasmon resonance stones below the surface (gold). But a square wave is a pulsation wave which has very powerful mechanics behind it as we are getting to soon.

Cheops SPOKE Pt 2

Now you can see there is a reason why these stones act one way while in the quarry and another way while they are somewhere else, because they are paramagnetic. Since each rock creates its own magnetic field, all the ions inside each one's crystal lattice all point in one direction together, creating a much larger magnetic energy. This is the essence of resonant conductive coupling that is such a significant part of Cheops' energy production process.

There is no doubt in my mind that if the surrounding area of the Ringing Rock Pluton shown above were to be carefully inspected, it would show signs of ancient civilizations that had made their home next to this massive field of free energy, just as has been found around the remains of other megalithic trees from past eras.

CHAPTER 14

SUPERSTRUCTURE OF THE PYRAMIDS



The structural stone blocks that Energy Temples such as Cheops are built out of, is *Aswan granite*. Granite is an excellent *paramagnetic inductor/transmitter* which perfectly insulates directional magnetic, photoelectric energy that has been suggested for use as the walls of massive particle accelerators (such as CERN) due to its ability to insulate (seal inside while uniformly dispersing

Cheops SPOKE Pt 2

thermal radiation) the energy of subatomic particles, both in their non-thermal "static" state as well as electromagnetic state. Since the ions inside granite readily follow the path of the energy flow while under an applied magnetic field (such as would exist during all experiments within particle colliders), their thermal conductivity and dielectric permittivity only supports their efforts to use energy to accelerate the speed of particles, not interfere with it. Granite is nearly entirely made up of quartz crystal, with a quantum dispersion of magnetite throughout, making this stone the ideal aggregate for the superstructure of the Temple.

Electricity always flows from warmer to cooler temperatures; this is the "bedrock" of the science of thermal radiation. Granite naturally thermally insulates this flow due to the fact that its resting state is cool, because it has been purified in the crucible of volcanic reduction, turning it into *igneous* stone. You already know this is code word for cation ion-state, or "low on oxygen". Like the oceans that can be considered gigantic cation ion reservoirs, it is naturally cold.

Igneous stone has to go through very intense levels of heat (2300 °F) in order to melt. This burns off all organic impurities that hold in or cling to heat, creating what is known as a *thermal conductor*. The nosecones of space shuttles are made out of the very same material as volcanic type stone (called ceramic) to withstand and dissipate heat all the way up to this identical melting point. So granite, a natural super-high-temp thermal conductor remains a few

QUANTUM ELECTRODYNAMICS

degrees below the standing temperature of the ambient air, very quick to return to this state once heated. This thermal conductivity is known of as the *K factor*, or the *lambda* factor which measures how easily heat is distributed across its mass compared to its R value which stands for *thermal resistance*. Of all known “natural” materials, **granite holds among the highest K factor (1.73) to R value (0.083)**, meaning it is an ideal insulator when dealing with massive levels of electrical flow yet still remaining cool. Another reason why when dealing with virtually nothing but electrons and ions, a particle accelerator might want to use this around its circumference to insulate it from the outside world where the soil would otherwise *burst into flames* (soil burns at around 550C, or about 1000 °F).

LIMESTONE INSULATION

The outside of the Great Pyramid is well known now to have been encased in huge slabs of polished, brilliant-white *Tura limestone* from the base to the capstone. Limestone, as we have already covered, is about as pure an electromagnetic insulator as can be produced, since its conductivity is on-par with glass. Also mentioned is the fact that this stone, as well as the Aswan granite interior, and the Basalt capstone, though of different species, are all entirely piezoelectric, quartz crystals.

Here is a sample now on display at the British Museum of the casing. As you can see, this isn't actually “white”, but is

Cheops SPOKE Pt 2

clearly a reddish-tan color on its polished surface. This is due to the fact that such limestone is luminescent and changes colors under direct ultraviolet rays. This is merely to establish that while Tura limestone is “white” as seen on the upper portion of Cheops’ partner Control Temple pyramid of Khafre which still has some of this casing intact, its interior shade beneath the polished surface is actually reddish. This will come into play next when we get to the Sumerian records of first-hand sightings of Cheops while functioning that explains there was a visible hue showing through that would not otherwise be present unless something else other than only sunlight was affecting its appearance:



Understand that the outer casing of polished limestone would not have been flat sheets covering over stepped granite blocks underneath, but would each have had to follow the exact outermost edges of each block, then

QUANTUM ELECTRODYNAMICS

extending out to the furthest angled-edge of the polished surface, as shown below in the inset at the top-right:

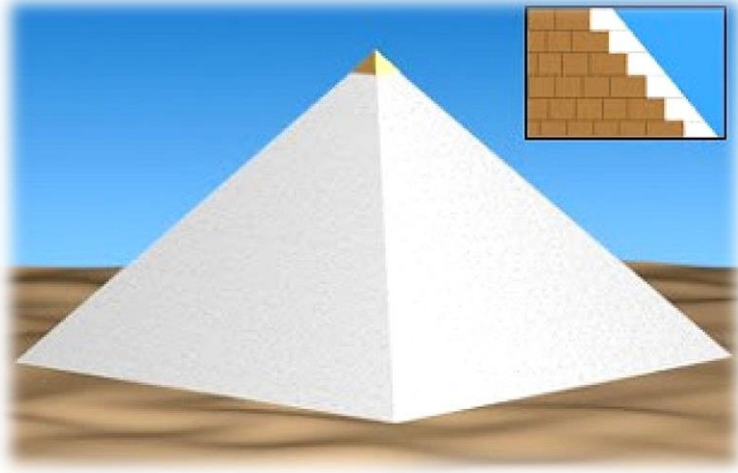

Once the generator cycled up to full power, the outer casing glowed much like a *light bulb*. In the **10th Sumerian tablet** the invader races of Sumer-Ur, the Anunnaki, documented this effect after the crystals (their term for the pyramids) had been activated by Enlil;

"Then Enlil by his own hand the Nibiru crystals activated.

Inside, eerie lights began to flicker, an enchanting hum the stillness broke;

Outside, the capstone all at once was shining, brighter than the Sun it was."

(On a separate account): *"Its interior with a reddish light of heaven glows."*

Cheops SPOKE Pt 2

This reddish light would simply not be present unless the pyramids had been lighted from the *inside*, because the polished surface refracted white under natural sunlight. And it still wouldn't be present if the limestone weren't actually red below the reaches of the sun's UV light. Something that would not be apparent in sunlight, even if it were viewed across one side that was in the shade. For the red to come through as a glow, it would have to have been through very, *very* powerful energy penetrating 7 million tons of stone *from the inside*. This is a very scientific way to verify that the historical record of the reactivation of the Energy Temples in Egypt was not likely to have been merely a fable, but the eye-witness account of this monumental event which couldn't have been merely a guess. While the Great Pyramid was an energy generator, it was also a "lamp":

QUANTUM ELECTRODYNAMICS

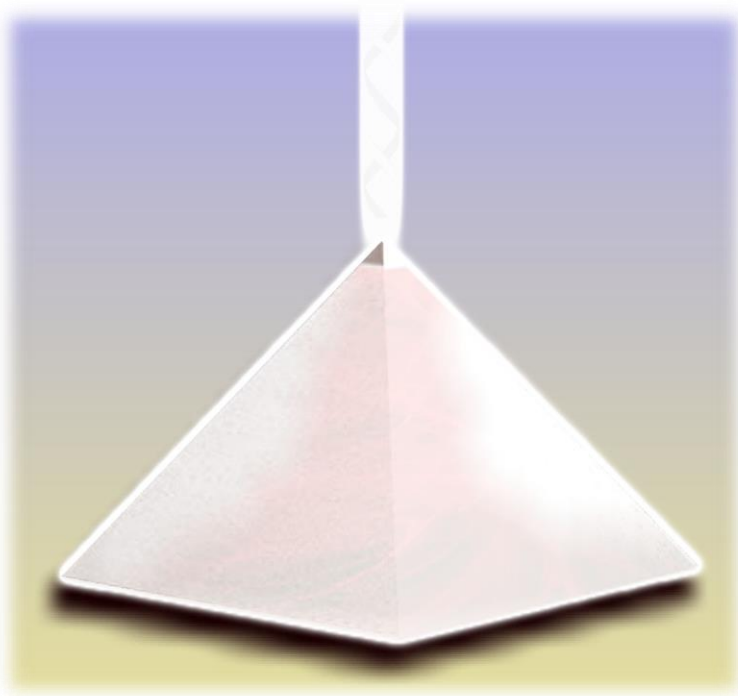

Today, all that is left of the casing after Cheops had been stripped of its polished limestone for use in other structures remains at the base of the north side below the entrance. As you can see, it takes on a yellow hue in shade, and a white hue where the sun strikes:

Cheops SPOKE Pt 2

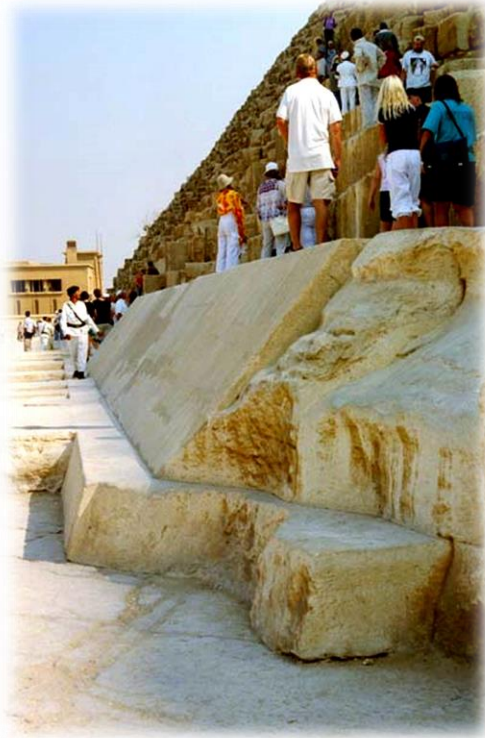

The casing stones, going from the estimated weight of those remaining at the entrance, were around 15 tons each. These are 5 feet wide and 8 feet long. There were over 100,000 casing stones used for the Great Pyramid alone, fitted within optical-precision across acres of surface. According to *Herodotus*, 5th century B.C. Greek historian in the oldest (human) written account of Cheops, the highly-polished casing stones that were still present at that time on all four sides (actually eight sides), were so precisely fitted together that their seams could hardly be detected.

QUANTUM ELECTRODYNAMICS

The limestone casings of Cheops and Khefre have now been positively identified as *formed geopolymer resin*. As an engineer for decades, I can tell you that there would be virtually no way a structure of this size could have ever been covered any other way, not even by the gods. Remember, the superstructure is made up of thousands of blocks, all differing in heights along every course, making it the next thing to impossible to fit pre-cut megaliths to fit tightly enough where a razor blade couldn't fit between. Conversely, pouring them into place would have made this very simple business. In comparison anyway. "Easy" is not a word I am going to use to refer to any of the construction of Cheops.

Limestone when reconstituted in a cement pour would have generated an even-greater glass-like misalignment of the crystal lattice structure of the product, making the outside even more insulating than with merely quarried stone, which leads me to believe that they were also poured geopolymer resin in their original construction predating its restoration by tens of thousands of years if not much longer:

***Microstructural Evidence of Reconstituted
Limestone Blocks in the Great Pyramids of Egypt:***

M. W. Barsoum and A. Ganguly Department of
Materials Science and Engineering, Drexel
University, Philadelphia;

"In summary, the simplest explanation for the presence of the plethora of mc's, some of which appear to possess chemistries and morphologies not

*found in the natural stone, is that the various ions were in solution and precipitated or **geopolymerized** relatively rapidly.”*

As you recall, the crystal lattice structure of molten crystals (sand) when allowed to cure rapidly, rather than over eons of time, are unable to reform into north/south alignment, rendering that melt as glass, an absolute non-conductor of electrons or ions. The very same misalignment occurs in reconstituted stone from small particles such as aggregate and pebbles of the original megalith. The casing rock used on Khefre and Cheops do not show any consistent patterns to indicate they were a result of megalithic quarry.

“GREAT PYRAMID OF EGYPT ELECTROMAGNETIC GENERATOR”

In a study reported by the *Journal of Applied Physics* released on 7/20/18, or one month after this report had begun documentation, scientists from *ITMO University* and *Laser Zentrum* announced they have found the Great Pyramid of Giza generates and then accelerates a “strong electromagnetic field”, showing modern science clues to potentially creating more highly efficient solar cells with further applications in nano technology:

“It is revealed that the Pyramid’s chambers can collect and concentrate electromagnetic energy ... In the case of the Pyramid on the substrate, at the

QUANTUM ELECTRODYNAMICS

*shorter wavelengths, the **electromagnetic energy accumulates in the chambers** providing local **spectral maxima** for electric and magnetic fields. It is shown that basically the Pyramid scatters the electromagnetic waves and **focuses them into the substrate region.**”*

*“The results can be applied to design nanoparticles capable of reproducing similar focusing effects in the **optical range**, [photonic light range]” scientist **Andrey Evlyukhin** said in an interview. “Such nanoparticles can be used as building blocks for construction of different optical devices for management of **light energy** at nanoscale.”*

*It has been shown that the Pyramid can **resonantly scatter electromagnetic waves** and support **resonant excitation of electromagnetic multipoles which resulted from strong electromagnetic fields** in the Pyramid volume.*

*Calculations showed that in the resonant state the pyramid can concentrate electromagnetic energy in the pyramid's **internal chambers as well as under its base, where the third unfinished chamber is located.**”*

While minor studies have shown the presence of a powerful electromagnetic field generated by the Great Pyramid, this formal particle physics study breaks down how the multiple resonating chambers created by the type of substrate (dielectric, paramagnetic stones) used in its construction allowed for an interlinked field-scattering of the energies

Cheops SPOKE Pt 2

generated within its design from the lower chambers then magnified within the upper structure to amplify its energy through the classic design of tapering down such electromagnetic particles prior to their application. In other words, it is a sonic multiplier as well as an electric generator, which is now shown on a molecular level to be a formal, provable fact based on particle physics, not a theory. However, the reason they were confusing the energy Cheops produces to be electromagnetic is by the mere fact that a simple metal tepee was fitted to the missing capstone surface which inverts its energy from ions into electrons as already covered. If they were to remove the tepee, all they would find would be massive levels of spectral ions.

It will be shown here how it is such chambers mentioned in the report are created using *waveguides* through *Saser* (ultrasonic laser) technologies that were clearly in place at the time of the original construction of the pyramid, and how it is the Temple managed to accelerate these energies up from an optical or photonic level (the energies found in salt water and crystals exposed to any level of light) into what is described as a strong electret-magnetic field as pointed out in the study. I only reference this report here to display that the notion of the pyramids being energy generators isn't something I came up with on my own. This is Cheop's story, not mine. I am just here to demonstrate how it worked through my pen as dictated by the force behind this report. In order to do this, we now take a brief look at how energy is taken from a quantum state and then amplified into higher and higher energy signatures.

TESLA INDUCTION MOTOR

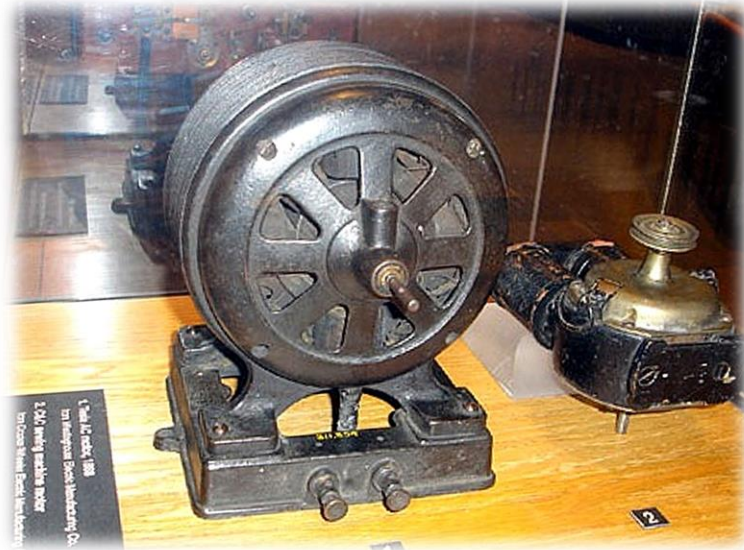

The above version of his “electromagnetic motor”, credited to Nikola Tesla from 1888, is the first positive-power induction motor to come under patent. Tesla made two of these original models, keeping one for himself, the other one he sent to a fellow scientist he knew he could trust with his most significant breakthrough if something were to happen to him or the first of the two prototypes. This motor would go on to change the world in so many thousands of devices today, it would be impossible to list. When Tesla died and all his lab notes and possessions stolen from his apartment by the CIA, his copy of this motor was scuttled away underground in the Vatican library where it remains

Cheops SPOKE Pt 2

today. Later, however, the second motor surfaced, which could not be simply spirited away without much explanation, rendering it to a modest display at the Smithsonian Institute where it rests today on display as the first A.C. electric motor.

Stripped down of its wires and behind glass, you can see at the center bottom there are two screw posts where two wires could be inserted for the energy to follow out of this induction motor to the appliance you wished to power. What you won't see are wires going into it (at least this is how I understood it when I was briefed on this subject). That is because it is secretly an overunity device that doesn't need to be powered in order to continue to pull energy directly out of the aether, something called the unified field. This design was reworked to utilize all its own energy just to turn the rotor to power something, plus it would need additional electricity to do that. Something that was accomplished by introducing brushes and commutators that robbed it of its free-wheeling, perpetual motion.

The motor above has two parts; a rotor and a stator. The rotor shaft turns inside the stator housing which then generates free electrons which circulate around the stator in a torus field. The metal casing and wires within this field collects the energy from secondary emissions, then sends them down an alternating current line to a destination that can link up to an A.C. electromagnetic device or to power, let's say a fan blade. It literally harvests free energy. But the unfortunate part about this is, it only harvests Dark

QUANTUM ELECTRODYNAMICS

Matter energy. And naturally, even Dark Matter energy was never intended to come to you without cost. Like paying for medications filled deliberately with nanites (all big pharma) and designed to perpetuate your malady, you have to pay to slowly kill yourselves.

The motors produced for the public based on this design are deliberately set up to use electricity coming through your powerlines to begin their cycling, and then only fitted with enough wire windings to keep the rotor turning if you continuously apply energy to it, so you will never be able to achieve free energy. In truth, this motor would start by pulling on a simple strap of leather wound around the shaft, at which time it would then simply run until the bearings finally wore out.

Today, secret space agencies use magnetic bearings (called *maglevs*) so there is zero contact of any surface within their over unity motors, so there is no such thing as friction, wear or drag. Magnets surrounding the rotor shaft suspend the rotor precisely centered to its axle so the shaft is continuously insulated in laminar air. Just like the brushes that apply friction to this design, there is no need to ask why they use steel bearings that need to be lubricated all the time instead; its to apply drag on the shaft so it can never spin freely, this way you also have to repair those motors on top of paying for them every moment of their use. All you need to do is bring it down to *Freemason's Electric* and have them replaced.

Cheops SPOKE Pt 2

In order to create an electromagnet, you merely need some iron, or simulated iron such as copper metal that is connected end to end inside a loop. Or in many loops that only increase the number of ions. That's it. By making a loop, you create a large torus field where these ions can now travel in a combined field together, making that loop possess a stronger magnetic charge than just a wire unraveled. If you send in more electrons from a battery or other means, they will continue to build up until the air around it "breaks down", allowing those negative electrons to jump into the closest ground.

All things have torus fields. If one field is Dark Matter, it will suck all the oxygen out of the air, which then clears a path for inverted electrons to reach Dark Matter metal as its preferred graphite/ash/cation-ion ground. The oxygen was the dielectric reluctance that was keeping those inverted electrons insulated. So when they say the air "breaks down", what they really mean is the oxygen was consumed which removed the insulation from the Aniline ions called "air". Electromagnetic energy always travels clockwise coming toward you, counterclockwise while traveling away:

QUANTUM ELECTRODYNAMICS

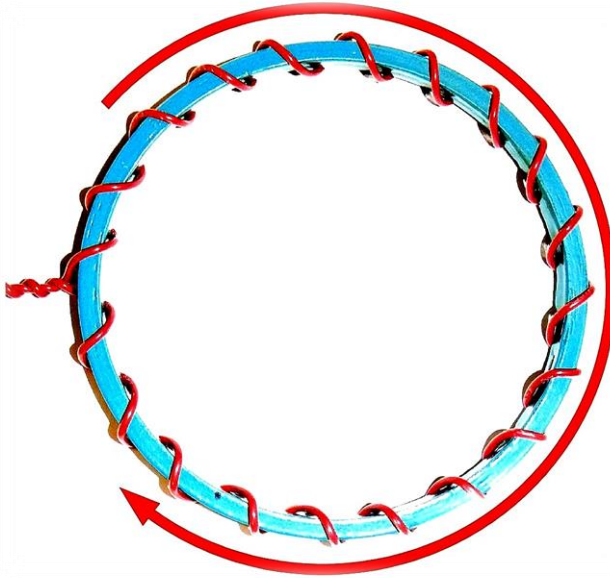

Ion torus fields exist around every crystal, as well as everything that is within the manifest world and below. These are all magnetic fields, however they are typically much weaker than Dark Matter electron fields generated by Dark Matter mechanical processes. Magnets carry more ions inside their valence bands than any other material, so the magnetic field around them is stronger than the rest of the standing, motionless fields. You can increase that magnetic force of attraction and repulsion simply by placing one looped wire inside of another looped wire and turn it in one direction. This causes the ions in the rotating field to travel, causing friction between the moving field and the stationary field and results in secondary emissions. Shamans looking to create a Meissner Field so they can levitate, walk in a clockwise direction which also forces the anion ions inside their body's magnetic field to travel as

Cheops SPOKE Pt 2

well, which builds up their own energy and the energies within the material things around him.

All forms of motion generate secondary emissions, thus elevating the energy around that thing. When you absolutely have to go to a party or a bar, dance, concert, etc., it is because your body is low on anion ions and you are looking for a boost energetically speaking. If you eat meat, then you are likely always low on energy, because unlike a carrot (“veggies”) that is anion ions, meat is cation ions, always low on fuel. While you can still generate secondary emissions from eating meat, you are generating the power for its ingestion from anion ions in the oxygen around you being absorbed by your body to rush into those cation ions. Whereas veggies provide those anion ions themselves instead. So it appears you are benefitting from meat, when in reality you are merely sucking anions out of the air around you, generating excess heat in your tissues.

MEAT SWEATS

You will never see someone eating a vegetarian meal break out in a sweat, but you will always see it when they are eating tons of meat creating what is called “meat sweats”. This is a thermal reaction which is attacking your genetic cells just like radiation from a Dark Matter torus field. Your body was never designed to eat meat, otherwise you would have carnivore teeth rather and herbivore teeth. Check yours to see which kind you have now.

QUANTUM ELECTRODYNAMICS

As yet another recap: when anion ions physically move, they strike stationary things full of cation ions which causes a secondary emission which creates brand new anion ions that now add themselves to the original torus field, increasing its magnetic force.

If our dielectric body generates secondary emissions from normal stationary cation ions, it generates more ions. But when our anion ions strike metal or steel that has had its oxygen removed, instead of generating normal ions, its “breaks off” the cation ions inside the metal’s outer valence insulation, inverting the “red wire” of ions to exposure to the open air, turning that secondary emission into Dark Matter electrons. A looped wire is just like your body, in that it creates a magnetic field, so when that loop turns inside an electric motor that has another looped wire surrounding it, the secondary emissions it generates are in Dark Matter electron form, whereas if that stationary field (the outside wire) had been dielectric (crystals) instead of a conductor (metal) of electromagnetic electrons, it would only generate balanced ions with the “red wire” fully insulated:

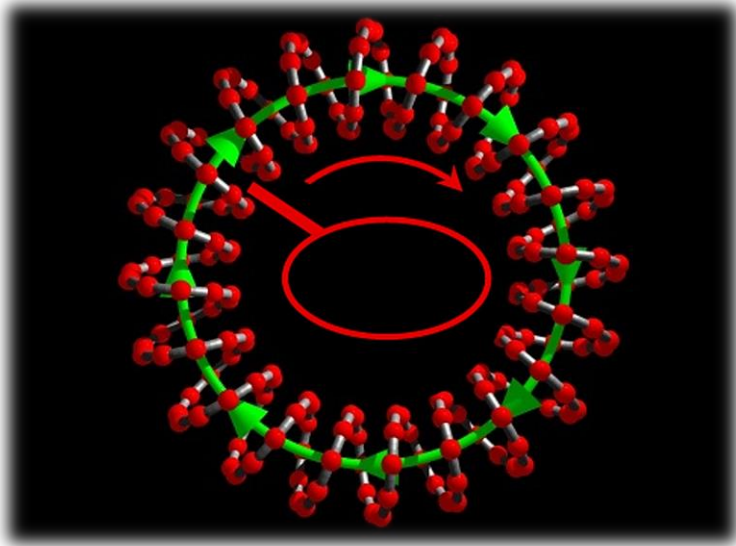

Inside an electric motor or generator, which are the same things, a torus field of Dark Matter electrons is generated by spinning a *rotor* (shaft) inside of a *stator* (stationary donut) as mentioned. Both of these are either loops of metal wire being fed electricity to increase their magnetic fields, or Redoxed magnets that readily conduct electromagnetic electrons.

The Tesla motor shown below was an A.C. induction motor, one of three ways Tesla submitted to patent for harnessing energy in 1887. This is a standard Dark Matter device, but it shows you a little bit about how physical secondary emissions are created using opposing stator posts to generate more than one phase as Cheops uses. This was a 2 phase Alternating Current model. That sounds fancy, but it really just means that the energy inside the torus field it

QUANTUM ELECTRODYNAMICS

generates is made up of two different but sympathetic (resonant) waves that are nested together and can separate at any time. You can have any number of phases, which just means more separate winding posts inside the stator (the soft metal posts of the housing around the spinning rotor that are each coiled with copper wires).

Three phase is the most commonly-used type today. By pulsing each phase at stepped intervals feeding to the bulb it fills in the visible gaps between energy pulses quickly enough that there is no flashing or strobe effect that is perceivable to the naked eye.

When Tesla brought his various motors to patent, he introduced the 2 phase as shown below that could also be modified to run as many as six phases (we are talking about the very first induction motor, not 40 years later, just to give you an idea of how far ahead of the rest of the world he was in understanding electric current):

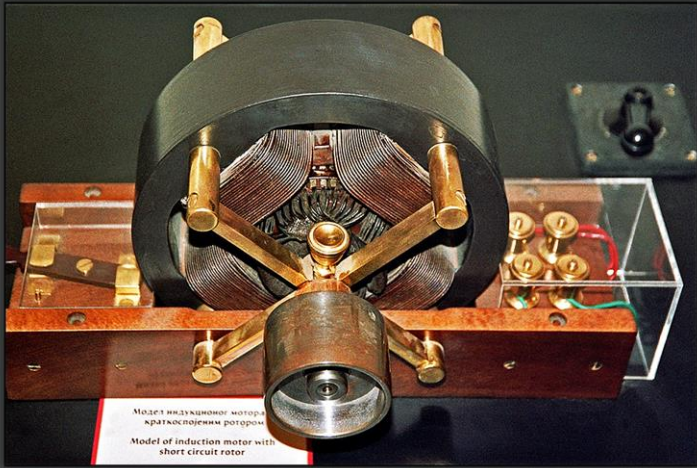

Notice how there are **4 primary posts** sticking out of this side of the motor above. This shows that this is a 2 phase, or dual-charged field that now generates two torus fields nested inside each other. In alternating current, these two waves travel down alternating wires, where they repulse each other momentarily to deliver alternating bursts of energy at the light bulb or device, but in the Energy Temples they will initially travel together prior to separating into synchronized processes that will ultimately come back together again once those are complete.

When the rotor turns, the posts on the top left and bottom right complete one field or phase, and the opposite posts complete the other. These are part of the housing surrounding the spinning shaft which is the stator. Stator means *static*, or non-moving. The two fields of the stator are synchronized in phase with each other and the torus

QUANTUM ELECTRODYNAMICS

field generated by the spinning shaft known as the rotor (rotating element) is slightly out of phase. This keeps the electrons flowing in a manner that keeps the shaft spinning in one direction. If you could see the invisible waves, they would look like they are constantly spiraling, as all energy waves travel.

Remember that only in a *mechanically*-generated torus field do you need anything to actually move. In a naturally-generated torus field (such as the levitation torus stones mentioned earlier that wiped out the homeland security computer network at the airport), the wave does all the spinning in its ever-forward, spiraling motion just like the ever-charging anion ion inside an atom. Those waves will be pushed, literally, through channels where they will begin their heavy secondary emissions by a separate wave that is generated by a moving object in the Control Temples such as Cheops, but we'll come to that later.

Here is a mechanically-generated torus field shown with the donut cut away. When seen in complete form, the waves generate an apple shape all around the center vortex:

Cheops SPOKE Pt 2

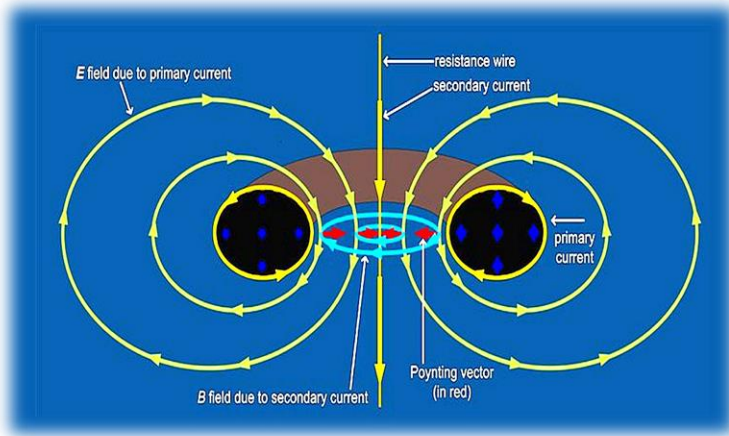

Notice that each arrowed line is always moving forward in a circling spiral, *stitching* itself around and around the donut. This energy will continuously seek the path of least resistance. In a *natural torus field* (non-moving parts such as a crystal), that resistance is called *magnetic reluctance*. This term is used only when energy is in a form that is considered static electricity, rather than being inverted by a moving torus field motor (or running down an extension cord let's say). This is correspondent to *electrical resistance* in electromagnetic applications (the energy we actually use). The spiraling energy looks like a corkscrew:

QUANTUM ELECTRODYNAMICS

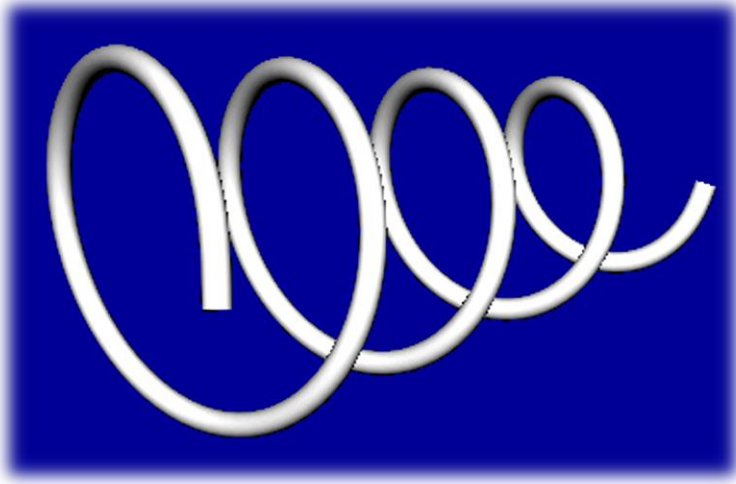

The complete torus field will appear like this, with the blue line showing how each wave travels in and out of the donut while spiraling at the same time. Every torus field is a **vortex wave that must pass through a zero-point** where it travels in the positive end and out the negative:

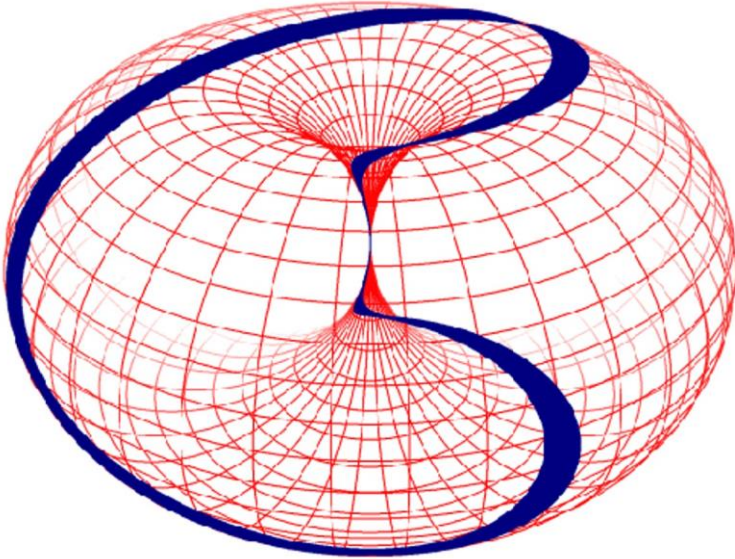

As we have just seen, when the copper wire is connected end-to-end to create a torus donut shape, that keeps the energy now continuously *moving* through the loop, which then creates the energy field around it in a much more pronounced, energetic form than merely with each end exposed just lying there in a straight line. When the rotor is not turning, those fields are still there and the ions are still traveling. When electrons are added to the field, the excess energy is now strong enough to attract the rotor to the next post in the field through magnetic attraction, so you see that rotor turn, even though you can't see any of the ions. None of the original ions ever leave the wire, nor do they "travel", the energy is only radiating from one ion to the next, all the way down the wire until it is released at the point of the brushes connecting back to the rotor to keep it turning. The Field Winding is the *stator (static) pole* and is equated to cation ions always thirsty for more energy:

QUANTUM ELECTRODYNAMICS

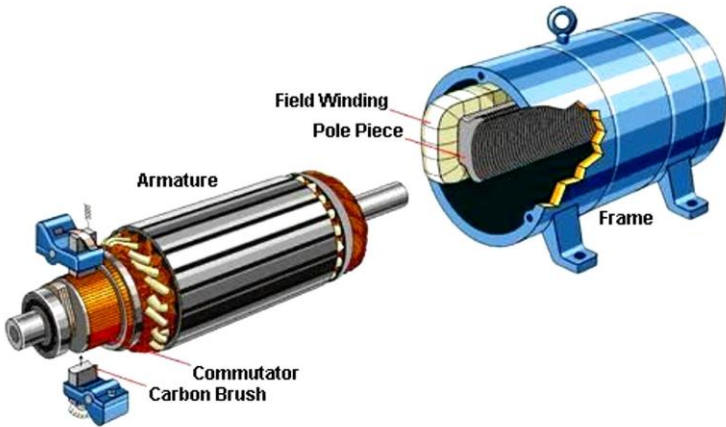

Overunity electric motors have been stumbled across many times of course by certain inventors over the years, only to have it hidden again by the black ops agents that typically eliminate the inventor at the same time. There are now perpetually-operating electric motors hidden in basements and garages around the world, secretly powering the homes of other inventors who have decided to just use the technology, rather than to hand it to the world, which would mean handing over their life in the process.

It is a fact acknowledged by US government employees there are thousands of patents that were intercepted on the patent desk that have been sealed as classified as well as Tesla's induction motor, so this isn't news. It was Einstein's job as a patent clerk to alert the government when a patent came in that was of particular benefit to humanity. It would be reviewed and allowed to go to patent

Cheops SPOKE Pt 2

as long as it was never truly overunity; otherwise Al would put it in an envelope and hand it over to the agency. Later he would be rewarded for his service by making him the biggest name in the history of science as the front-man for the lie of Pi.

I have mentioned before that Tesla's father was the curator of the Vatican archives where ancient records from Atlantis and the supposedly-lost papers of the Library of Alexandria Egypt in the fire of 48 B.C. are stored today. When he came back from school each day, Nikola would join his father there for a few hours before he got off of work, so the young man would spend his time reading these ancient scientific papers and texts that taught him how to capture energy from the aether. I am sure he was also a genius, but he definitely did not get his information from mere deductive reasoning.

This is the inside of a *2 phase motor*:

QUANTUM ELECTRODYNAMICS

(No Model.)

4 Sheets—Sheet 2.

N. TESLA.

ELECTRO MAGNETIC MOTOR.

No. 381,968.

Patented May 1, 1888.

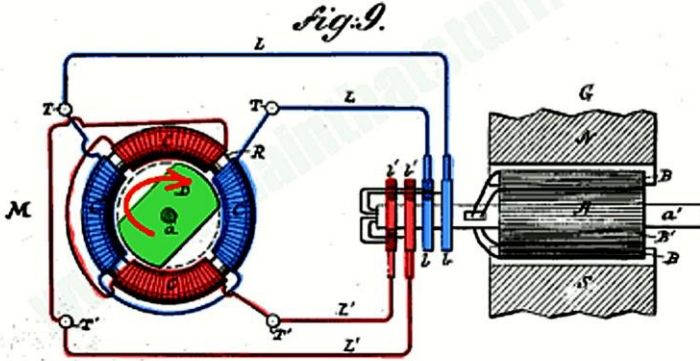

This gives you an illustration of the inner workings of the Dark Matter electric motor. The green rotor in the center is set to turn clockwise, while the blue and red arcs surrounding it make up the stators (this view is looking away from the motor shaft). The blue arcs are one phase, then the red arcs complete the magnetic attraction to bring the rotor to the next phase. By sending in a surge of electricity, the magnetic field of the two phases of the stator intensify, which begins the rotor turning in one direction. Understand that if these four stator windings had a stronger magnetic field and no friction was applied to the axis points, no surge would be required to begin the movement, rather only a small nudge of the rotor.

In ion generators, *inductive coupling* is the method used to transfer phonons through the air from one dielectric crystal to the other. You already know this is achieved simply by

Cheops SPOKE Pt 2

using the correct size and type of the receiving crystal so it resonates at the same frequency as the broadcast crystal, based on how far that wave has to travel. The further the distance, the larger the crystal. This is safe, wireless, clean energy that will still power your bulbs and turn your fans. This method as shown in this photo from 1910 has been around for over 100 years and still you continue to use Dark Matter through clumsy power cords to deliver microwaves that are killing you:

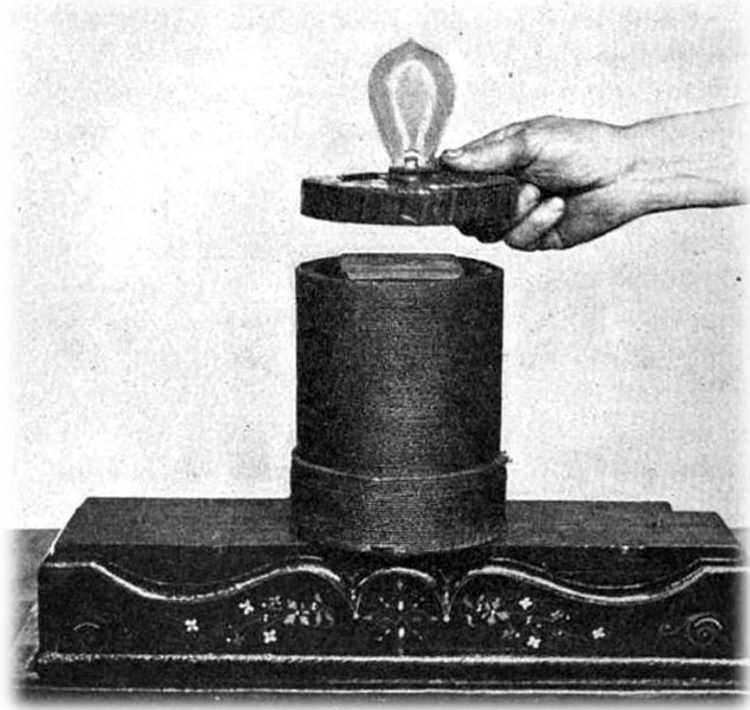

Next time you see a lightning strike, just remember that the energy that was being emitted into Urth's field from the

QUANTUM ELECTRODYNAMICS

cloud was transferred and that enormous energy of the bolt itself was entirely *secondary emissions* that kept all the anion ions still right there in the air. There were no spinning rotors involved, but merely the wind current that led the anion ions in the air to the cold, anion-depleted surfaces that needed reheating and recharging. It is the job of the anion to keep the temperature of any anode (a collection of cations such as Urth and water) at the same temperature as you will see when we cover magnetrons coming up soon. This frantic movement back and forth over that surface generates a pulsation which is the Schumann Resonance. In magnetrons, the pulse creates a square wave which we are also about to cover.

ELECTRICITY DOESN'T TRAVEL

When a superconductor transfers energy, it has absolutely nothing to do with electromagnetic electrons, since it repels (utterly cancels) all Dark Matter (“strong” force) magnetic fields (just as dielectric stone repulses against any strong magnetic field). The energy must be transported in phonon form in order to get electrons to holds hands through Cooper Pairing. Collecting then the energy on the other side of the superconductor, you recall now that science uses copper wires that have been harmonically tuned to the superconductor which then triggers the release in the direction of the electrons moving through the wire. This transduces phonon energy from stasis into electromagnetic. I want to point out here that this is certainly not the only

Cheops SPOKE Pt 2

way to use stasis energy, but within the construct of MS science, using wire is the first choice.

The truth is, the wire inside the copper that makes up the windings in a motor (which emulate a magnetic field) is already full of charged anion ions. The electromagnetic field that the generator develops only causes those ions to vibrate, which sends the signal down the wire that states; “there are now extra ions over and above the capacity of the wire to contain that are now trying to get in”. This is because electrons don’t actually move from here to there, they only vibrate. The more ions attempting to get into that valence, the more vibration which we would call volts.

In fact, it has been positively shown by science that there is no such thing as motion beyond vibration alone at any particle level.

People do not move, birds don’t actually fly and baseballs don’t actually travel across the mound. Only the vibrational signal from one ion, atom or molecule is passed along to the next ion or atom through “bumping into” the next one which then passes it along to the next and the next in a chain reaction. As covered in previous volumes, the spacetime fabric pixels light in sequence, causing that message or command to take visible appearance and this goes for the same ions that are carrying the message of a movement or action that is above or below our senses. And while this fact may make this subject more confusing even

QUANTUM ELECTRODYNAMICS

yet to grasp, it is important to understand so you can follow how a superconductor actually works.

When a superconductor generates a Meissner Field, both the conductor and the magnetic or paramagnetic object that is now locking in this field are in suspended animation. I suppose you can say they are in stasis, just like the energy inside a crystal. This makes all distance, time and gravity cease to exist within that sphere that now becomes a single, pulsating molecule. A zero point is the release from active material manifestation and is powered by a combination of fission and fusion reactions to generate power. The vibration of the energy normally in electron form now simply goes anywhere within that field instantaneously and directly back into balanced ion form. There is no handing-off one vibration to another as happens within a copper wire, because all the particles within the field are now vibrating as one single entity. All the energy stored in the capacitor of the superconductor, and all the energy in the magnetite are now sharing the same space, just as Higgs Bosons. But here's the really important point:

*All the energies within every cell of that superconductor (which is now a single, phased-locked, magnetically-powered crystal due to the magnetite present within its field) still functions under the same physics as it did while in electron-form, only **without impedance** (resistance or friction).*

Meaning all the amplification processes (secondary emissions, sonic chamber resonance, etc.) still take place, but the speed in which it functions is instant rather than hindered by the friction normally associated with such electromagnetic flow channels while in regular “material” form.

What is necessary to understand, is that the aether already knows the architecture and intent behind the desired result, before the first crystal goes into a superconductive state. As explained earlier and proven in the Double Slit Experiment, as well as many other experiments on DNA, it knows 3 seconds in advance because the intended experiment on one half of one DNA cell separated from the other by feet or by miles from the other, changes **before** the half that is about to be tested. So every secondary emission that was supposed to happen in a real-world, physical state now happens instantly within a Meissner Field, which results in both amplification of energy as well as superballistic “travel”.

As we are about to cover in the chapter THE TWO GREAT PYRAMIDS and more extensively under the MAGNETRON WAVEGUIDE section, planar surfaces (like flat, or precisely curved with sharp edges) of material things generate secondary emissions, just like one ion striking another. It is the secret behind *photomultipliers* which are actually magnetrons, synchrotrons and cyclotrons which all use friction and deflection to achieve

QUANTUM ELECTRODYNAMICS

the multiplication of ions or electrons. So if there are planar surfaces inside a superconductor, each one will carry the potential to amplify that energy. Super conductors are typically made out of such things already shown as graphite and graphene. An entire industry was created around these little precision surfaces as we covered previously under **cationic surfactants** (two bonded square pyramids) that creates a perfect optical sphere in that torus field. But planar surfaces with sharp edges work to generate massive levels of energy as well. So the superconductor itself is a quantum energy power plant.

Here is a larger-view microscopy of graphite below. Realize this is many times less power than an electron scanning image that shows that the quantum atomic signature of graphite is actually incredibly perfect octahedrons. Now realize that the flat sheet structure is exactly the same quantum construction of standard crystals (and fingernails, hair, etc.) where they are made in many layers of flat planar surfaces with sharp edges. This means when the photon or phonon enters that crystal, it deflects off of one surface only to run into another and another and another, all the way to the core of that stone. And each strike generates secondary emissions equal to the original ion. So one photon can become millions of ions, just by traveling into that capacitor:

Cheops SPOKE Pt 2

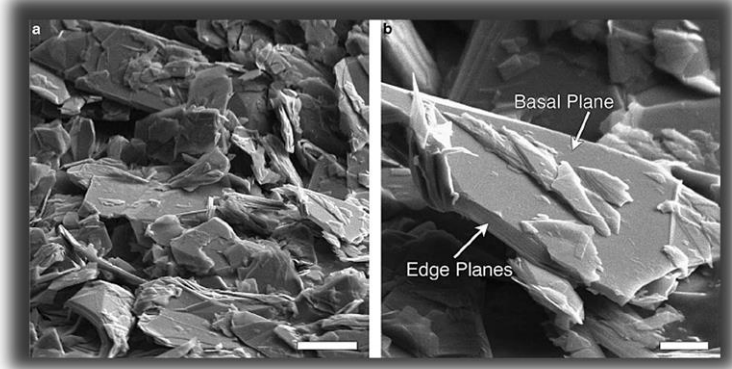

And of course, 100% of this energy comes from SET, or Static Electric Transfer that multiplies even the subtlest of energies. Every single planar surface within that superconductor is factored into the energy that emits out of the other side before it has even gone into a Meissner mode where the power is simply on the other side of the superconductor 3 seconds before it is even applied. And the reason is clear; the magnetic field that caused the zero-point suspension field resonated together with the superconductor as a single entity or molecule. No electricity has to move anywhere, because it simply vibrates as a single cell through network covalent bonding and exists as the standing quotient of how the vibrations of each ion would take if it were to pass through in physical, 3D form. The ions literally “read the book by its cover” if you will.

“Ions” are Aniline crystals. They are real life batteries I have already shown you a picture of and are the resident capacitor at the atomic core of a water mist particle, or at

QUANTUM ELECTRODYNAMICS

the core of millions of these mist particles that make up one full drop of water that forms into a perfect sphere. There may be “a million” Aniline crystals inside that droplet, but they all “act like” one according to science. As just mentioned, this is network covalent bonding or *NCB*. All energy “travels” through vibration alone, and only through a relay from one Aniline crystal rubbing against, or “striking” another Aniline crystal. The Meissner Field is merely an example of perfect harmonic resonance of all the crystals that are within that field as one. This becomes significant when you realize I am about to show you a 13 million-ton single molecule with a uniform atomic crystal lattice from front to back and from top to bottom with perfectly angled planar surfaces trillions of times greater than the ones you are looking at here that *each one* turns one phonon into two.

CHAPTER 15

TESLA COIL GENERATOR



Above is a *Tesla Coil*. When electricity is concentrated, or amplified into a beam, it travels in a spiraling wave as covered, and when channeled through a reducing cone-shape, the resulting energy condenses into a powerful zenith many times greater than it started out through continuous secondary transmissions generated from the surfaces of that cone we are about to explain in a moment. The random sparks you see above are simply arcing from

Cheops SPOKE Pt 2

an electrode torus ring from the multi-staged electromagnetic generator below which breaks down the air then leaps outward in random directions to the cation ions (partially-depleted anion ions) in the atmosphere which absorbs this energy release.

As you can see, rather than in a uniform “laminar” manner, they now travel like unfocused lightning bolts in all directions. So here you are seeing what the sparks coming out of Dark Matter electric motors look like that are being *literally* tossed into the wind. Tesla Coils are actually used for modern applications, but this display was designed to use ultra-high voltage just for entertainment value. The egregious production of energy created in the Tesla Coil is so powerful that you are able to see it with your eyes, unlike the more subtle emissions tossed out from electric motors, transformers, power lines and generators.

These high-voltage electrical bursts you see being transferred into atmospheric electrons are only visible because the coil is temporarily inverting Dark Matter energy into material existence on a level within the human visual spectrum.

MAGNETOSPHERE

In a similar way as the coil above, lightning bolts from clouds are inverting static energy into electromagnetic

THE TWO GREAT PYRAMIDS OF EGYPT

energy momentarily to release excess anion ions back to ground that have built up which is possible due to the Urth generating what is called a magnetosphere, or a *planet-sized torus field*:

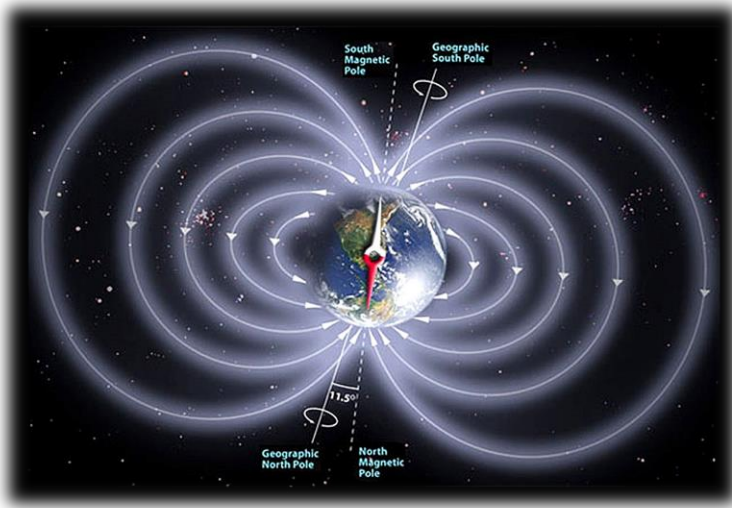

Urth atmosphere or what we call air can be thought of as a *negative energy torus field*, and the planet can be thought of as a *positive energy torus field*. Together they work as one molecule or one crystal that constantly exchanges energy between its two waves. The air is the Light Matter wave, and the planet is the antiparticle Dark Matter wave. Like the continuous *neutrino oscillation* of up quarks and down quarks, lepton quarks exchange between neutrinos which keep them all in neutral form. So in real terms, Urth can be thought of as an iron particle (the red wave) **magnet**, and air can be thought of as a giant **dielectric** (antimagnet) Aniline crystal which is the carrier or **fuel**

tanker of oxygen/hydrogen that powers these two sides of the one “**magnet-o-sphere**”.

Once the energy in the air reaches capacity from sun wave photosynthesis, free ions send back what it doesn't need through friction you already know as SET, or static electrical transfer. Each leaf and plant provides a solid surface for ions accelerated by the wind to crash into, creating secondary emissions which are absorbed by that living thing. Flat or concave planar surfaces not only create these secondary emissions, but deflect the original ion plus the secondary emissions in concentrated beams that carry much more energy moving through the air than originally held by the wind alone.

The ions created by wind merely striking the flat planar blades of a windmill are generating a million times the energy being captured by turning the fan which turns a generator which then captures 4 electrons that slowly recharges your battery. Instead you could merely set up a resonant inductive coupler to the entire building made of flat planar sides to store those ions in a pile of crystals (outside in the sun). Better, make the building out of quartz crystal and use it to store the secondary emissions while being continually recharged from photosynthesis.

That battery would never be empty, because when clouds are blocking out the sun is usually when you get the most wind.

THE TWO GREAT PYRAMIDS OF EGYPT

Perfectly square pyramids, tetrahedron or octahedron surfaces have the ability then to “aim” energy like a mirror into another corresponding planar surface to compound this effect. This is why crystals all lumped together in crystal caves remain at 136 degrees, because they are teaming with energy on a grand scale. You recall now, that these giant crystal clusters are what resonate in sympathetic harmony with the pulsation generated by ions rushing from one cold surface to the next across Urth’s surface to equalize thermal signatures which then set the Schumann Resonance. Even though these caves are below ground where wind and solar waves cannot reach them, still the neutrinos that supply this energy to these giant crystals pass through matter, therefore are easily able to reach their capacitor destinations.

Although this is all ion energy from neutrinos, still there is so much friction involved in the exchange, a thermal signature cannot be avoided simply because a neutrino event always releases *Light Matter with its corresponding Dark Matter wave* that creates a spark when it strikes a crystal, turning into 3D ion energy. Large crystals are fixed with flat planar facets like Aniline crystals, and both are recharged by the same sun waves that are filled with neutrinos. The only difference is Aniline crystals are microscopic and are light enough to be carried in the air to dispense that energy over the entire surface of the planet directly through the SET process, lighting and heating the atmosphere as well as the surface of the planet. If just one crystal cave cluster were to suddenly invert at once into

Cheops SPOKE Pt 2

Dark Matter, the heat produced would be enough to vaporize this entire planet.

On top of SET transfer, when photosynthesis (which is just another word for *neutrino event*) builds up in excess of what has already been imparted to surface life, now a major discharge is in order to keep the “molecule” of Urth in energetic balance. That sudden discharge then comes in the form of lightning as discussed. Once the bolt reaches ground (or a bolt reaches up from *ground-to-cloud*), this now grounds that energy once again into static electricity which is held inside of iron-rich magnetite which can absorb incredible levels of ion energy. So Urth and sky together can be seen as one very large neutrino that is forever changing parity inside in order to remain neutral which simply means in balance. Balance is also called *sympathetic harmonic resonance* referred to as **Triplet State** in particle physics. So if you could hear the one pulsation between Urth and sky in this harmonic resonance, once again it would sound very much like *whoom whom*.

Iron is “ground” to Dark Matter. Synonyms are: Lack of oxygen (hypoxia), Magnetite, Electrons, Magnesium, Metal, Ash and Graphite.

THE TWO GREAT PYRAMIDS OF EGYPT

Crystals are “ground” to Light Matter.

*Synonyms are: Cations, Water, Salt, Soil
and Protons.*

Organic iron acts like a **semiconductor**, or a **transducer** of pure Dark Matter energy into a wave that can then be readily absorbed once again by a dielectric crystal. This is why iron releases its magnetic field, where magnetite retains it. A magnetite crystal is a square pyramid shape at its quantum core (as well as in a whole crystal you can see), which is the geometric symbol for “closed loop”. There is no “out” door for the energy to travel through. Iron however, is made up of Aniline crystals at its atomic core structure, which has both an “in” doorway and an “out” doorway. So while magnetite might be “iron”, it is also a closed loop and therefore maintains full power and never loses its charge. The “out” doors of an Aniline crystal are the little openings at the bottom of each opposing lambda Λ of its planar surfaces at the center of each meridian connection point between the two connected square pyramids. Here’s a second look. Remember, energy doesn’t come in and out of crystals from their tops and bottoms, but through their sides, and always perpendicular to their points:

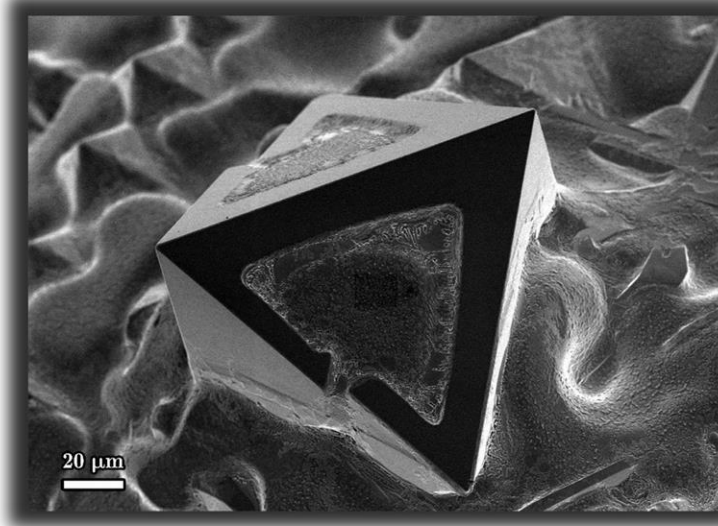

Crystals with iron deposits in them with most of the oxygen removed such as copper do not transduce Dark Matter in this same way, which is why to become a pure electromagnetic conductor, it must go through smelting Redox (*removing-all-oxygen from its outermost valence bands*), so Dark Matter remains inverted. Bismuth crystals (and all its various species of crystals it holds in its core valence that can each one grow independently of each other) is “organically” Redoxed, or missing the oxygen component. So graphite, which is a Bismuth product, is already in hypoxia, thus is fast to transfer Dark Matter energy like a sieve. Magnetite retains that transduced Light Matter energy so it can be used in conjunction with crystals to apply a magnetic field which “sings” to free ions as an incoming receiver. There are millions of times more iron deposits than magnetite deposits for this very reason. The Urth is the grounding rod of Dark Matter lightning strikes.

THE TWO GREAT PYRAMIDS OF EGYPT

Magnetite can also take the same shape as carbon, graphite and Aniline in an octahedron shape, but as you can see here, it is missing the “back door” for energy to escape, making it a closed loop:



DELTA ▲ LAMBDA ▼

Cheops SPOKE Pt 2

As has been heavily covered in past volumes, the Delta symbol \blacktriangle in science stands for “eternal” or “aetheric” energy. The Lambda symbol stands for “3D” or “fermion” energy \blacktriangledown . But in structural physics, the Lambda symbol looks exactly like one of the eight planar sides of an Aniline crystal (the name itself using the actual symbol) Λ and stands for its K factor we have already discussed, which is its ability to conduct thermal radiation or heat, yet still retains its ability to work as a capacitor to hold in energy at the same time. Those minerals that can dissipate thermal radiation yet still carry a static charge are measured much differently than those who are unable to maintain a charge such as ash.

*Simply put, the Delta is the CLOSED LOOP that is the actual Cellular Language Command Signet of eternal energy held inside a magnetite crystal that is known to absorb and contain heat, but the Aniline crystal that has the “opening” to absorb and immediately dispense thermal radiation is an ACTIVE LOOP or one that has an escape door for the heat to travel out of. Is it merely coincidence the symbol used for the “K factor” also called the **Lambda value** would just so happen to have this extremely specific geometric shape that is used in place of the letter i which is the actual symbol of the god Wawwu?*

Of course you already know the answer: Greeks who used this exact symbol knew all about quantum

THE TWO GREAT PYRAMIDS OF EGYPT

*particles, because the word “Greek” is merely a synonym for “Sumerian”. When the Greeks “adopted” the Phoenician (Sumerian) written symbols, they named it the “**Ionic alphabet**”. Do you think it had anything to do with ions?*

MAGNETOSPHERE CONT.

As we have covered recently, when crystals are placed together, each crystal pulsates, but each one of their pulsations automatically synchronizes with each other, just as shown in volume 1 under METRONOMES, where musical devices set to the same beat all at different stages of their pendulum swing when placed within the field of each other, reset themselves to swing together as one. Science has no explanation for this natural synchronization, but is forced to admit that it is still fact. This is because each metronome creates a torus field, and when two or more come within each other’s vibrational space, they seek harmony because in the most real sense, all of those metronomes at their crystal lattice level become one through *network covalent bonding*. So what you are seeing in the Schumann Resonance, or the heartbeat of Urth, is trillions of crystals who ultimately synchronize to each other all around the globe to agree that this is the one unified pulsation rate they are all going to resonate in, set by anion ions striking the planet.

CRYSTALS ARE NOT MADE OF ATOMS

It is incredibly difficult to understand energy the way SM science likes to label things, and it is incredibly important to understand energy if you are going to use it safely. I keep using terms like ions and electrons to indicate different things, so I am pasting here an example of the explanation between the two as explained by science to demonstrate just how common scientists use the word “electron” to stand for static electricity, hoping you won’t catch the switch. Also understand that ions are referred to as “atoms”, but this is also merely *misdirection*. When broken down physically in scientific-specific language regarding the actual Aniline crystal that is the only known carrier of energy within creation, it is technically not an *atom* at all. We’ll get to that in a second:

*“**Negative Ion** (also known as anion) is an atom carrying a negative charge [remember; this means outflowing, full-gas-tank energy] due to the presence of additional electron(s). [There are **no** “electrons” in an **ion**.]*

*An **Electron** is a **sub-atomic particle** with a negative elementary electric charge. Number of electrons in an atom is equal to no. of protons which counter-balances the charges of an atom making it electrically neutral.” [The word proton is only a **hidden** term for **anion ion**, and the word electron is only a hidden term for **cation ion** that is designed to remain **stationary** and not whirling around in the open air.]*

THE TWO GREAT PYRAMIDS OF EGYPT

What also isn't explained in the above text is the fact that the whole ion made up of both balanced waves in neutral form (insulated) is secretly oxygen as I have already alluded to. The much smaller electron is merely one side of those two waves that has been inverted or turned inside-out through a process of removing its ability to produce oxygen which is the roadblock man continually faces while trying to reach *actual* energy. It might seem like we have already covered this, but the hidden secrets inside crystals has yet to be fully explained which you will be keenly interested in now that you have some idea of the grift that has really taken place. I know the constant interchanging of the words electron and ion appears on the surface as subtle, and possibly merely *semantics* alone, but inside the real role these two "particles" actually play is the single biggest lie ever perpetrated on mankind after their enslavement itself.

By now you know that the energy of ions in stasis form is not in an inverted, electrified magnetic state. While in the atmosphere and therefore insulated, ionized air (in this case, I am talking specifically about "negatively charged" or full of energy ions) has been shown in clinical tests to benefit the body in numerous ways, making an **ion air purifier** extremely healthy. The Energy Temple Network didn't simply place ultra-high levels of free energy in the air around their communities; they also extended longevity and improved health. These are some of the benefits from having **ionized air**:

- Better sleep

Cheops SPOKE Pt 2

- Easier breathing
- Faster recovery from illness
- Less severity and frequency of colds and flu
- Enhanced oxygen intake
- Increased energy
- Better concentration and learning
- Stress relief
- Improved vascular system
- Removal of airborne pollutants including passive smoke
- General health and wellbeing
- Immune system recovery
- Reduction in Allergy and eczema
- Assisting with Chronic fatigue

Something they don't come right out and explain to you in science class is that crystals aren't solid, they aren't liquid, they aren't gas; and they aren't even made up of millions of atoms. One crystal is one macromolecule; from Aniline too small to see to the one around your neck and larger. And at first, it doesn't make sense to hear this, because all things are made up of atoms that make up molecules (if you can see and touch them), which means they are **fermions**. You recall now that fermions mean ions that have taken a **firm**

THE TWO GREAT PYRAMIDS OF EGYPT

or matter-state. Either they're liquid, gas or solid that can turn into one or other or all three, such as Aniline crystals which appear as **ice** or **quartz** crystals when solid form, appear as **water** in liquid form and as **oxygen** when in gas form.

As I have stated before, the energy held in crystals such as quartz isn't matter, even though we can touch and see the shell it comes in, because it is a multidimensional thing that crosses the "veil" into any other dimension or interdimension it chooses. It is only here when it is needed in our dimension, and when it isn't, it is in the 5th dimension or elsewhere.

But I don't have to try to convince you that crystals aren't like all other material or matter things (such as monoatomic gold isn't actually a material thing that weighs less than nothing and disappears at a certain temperature), I will let science explain it:

*Wikipedia: **Crystal**;*

*"A **crystal** or **crystalline solid** is a solid material whose constituents (such as atoms, molecules, or ions) are arranged in a highly ordered microscopic structure, forming a **crystal lattice that extends in all directions**. In addition, macroscopic single crystals are usually identifiable by their geometrical shape, consisting of flat faces with specific, characteristic orientations.*

Cheops SPOKE Pt 2

*A crystal structure (an arrangement of atoms in a crystal) is characterized by its **unit cell**, a small **imaginary box** containing one or more atoms in a specific spatial arrangement. The unit cells are stacked in three-dimensional space to form the crystal.”*

Crystal lattices (the ordered atomic structure of all things) are typically made up of layers, with multiple types of patterns within their molecular composition. Material things are composites of different types of atoms (differing numbers of ions that normally “rest” inside the valence of that species of atom) that make up a molecule. But a crystal such as quartz or Bismuth among others, has *no break to their pattern* which travels from one end of the crystal to the other as well as front to back, *unbroken in an infinitely connected and perfectly-ordered* manner.

In fact, in these types of crystals that produce high levels of piezoelectricity, *their individual atoms cannot be identified* (found), even under electron-scanning microscopes that can focus down over *one million times* smaller than the naked eye can see, so it is simply *assumed* that there has to be individual atoms that make up that structure in there somewhere, because there is with everything else we call matter. So to overcome this minor missing element that makes a crystal somehow real and not a fictitious thing, they not only literally make up such claims that “individual atoms are inside the crystal that are perfectly ordered”, but then they are forced to also imagine a box for them to fit inside of.

THE TWO GREAT PYRAMIDS OF EGYPT

While they can photograph the **image** of the Aniline molecule, and they can photograph the pyroelectric **energy** it emits, simply put, they are unable to find any “particles” such as quarks inside of it. And when they slam Aniline crystals together inside a particle collider, what emits is only energy alone. There is no matter or dust left inside the collider. The pictures of such annihilation reveal *geometric patterns of light alone*:

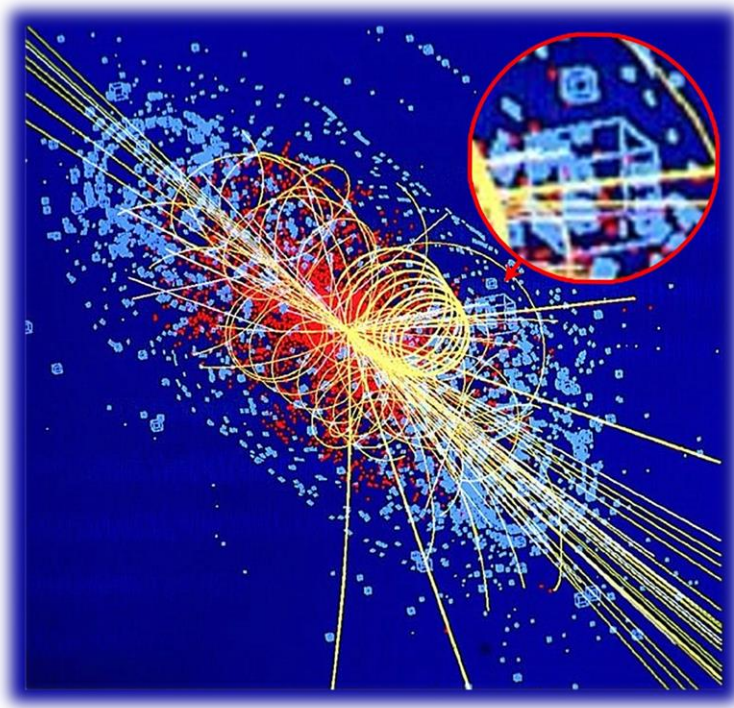

Reading further down Wikipedia explains how some crystals (like monoatomic gold, quartz among many

others), choose if they are going to be seen or not, and in what form. Bear in mind that the use of the word “atom” within the context of crystals is *assumed only*, even though no atom has ever been found inside a crystal, but *covalently bonded* (Cooper Paired) twin-wave energy photons alone which is casually called an electron in such Wiki reports, but is **specifically and clearly really an ion**. NOT an inverted Dark Matter electron exposed to open air. I would like to point out, that this is *Standard Model Science* that is referring to **water** as crystal, not just me. It is simply known in science that water is liquid crystal, solid crystals are solid oxygen and none of them are actually “matter”:

Wiki: **Crystal**; (*Polymorphism and allotropy*);

*“The same group of atoms can often solidify in many different ways. **Polymorphism** is the ability of a solid to exist in more than one crystal form. For example, water ice is ordinarily found in the hexagonal form Ice, but can also exist as the cubic Ice, the rhombohedral ice II, and many other forms. The different polymorphs are usually called different phases.*

*In addition, the same atoms may be able to form noncrystalline phases. For example, **water** can also form amorphous ice, while SiO_2 can form both **fused silica** (an amorphous **glass**) and **quartz** (a crystal). Likewise, if a substance can form crystals, it can also form **polycrystals**.*

For pure chemical elements, polymorphism is known as allotropy. For example, diamond and graphite are two crystalline forms of carbon, while amorphous carbon is a noncrystalline form.

THE TWO GREAT PYRAMIDS OF EGYPT

*Polymorphs, despite **having the same atoms**, may have wildly different properties. For example, diamond is among the hardest substances known, while graphite is so soft that it is used as a lubricant.”*

With all this said, how do scientists explain crystal? By referring to it as something that is held together through **network covalent bonding** rather than **atomic** in structure:

*Wikipedia: **Network covalent bonding**;*

*“A **network solid** or **covalent network solid** is a chemical compound (or element) in which the atoms are bonded by covalent bonds in a continuous network extending throughout the material. In a network solid **there are no individual molecules**, and the entire **crystal** or amorphous solid may be considered a **macromolecule**.”*

Before physicists get all tied in a knot over this, covalent bonding is something that happens through chemical bonding of shared ions (Cooper Paired “electrons”) under multiple forms and is not a new or unique way to explain macromolecular bonding in quartz or other crystals. I am not saying that it is totally unique to just piezoelectric crystals, but to all crystals including the ones at the quantum of water and air shown above in the recent image actually captured of Aniline shown above. “Covalent” really means *Cooper Pairs* which are in a “stable electronic

configuration” within the hidden cipher of scientific language:

Wikipedia: Covalent bond;

*“A covalent bond, also called a molecular bond, is a chemical bond that involves the sharing of electron **pairs** [ions] between atoms. These electron **pairs** are known as shared pairs or **bonding pairs**, and the stable balance of attractive and repulsive forces between atoms, when they share electrons, is known as **covalent bonding**. For many molecules, the sharing of electrons allows each atom to attain the equivalent of a **full outer shell**, corresponding to a **stable electronic configuration**.”*

The point I am making is that due to the lack of any distortions within the makeup of these species of crystals and crystallines within their lattices that cannot be seen or photographed and therefore must be assumed to be there, the **crystal is factually considered a macromolecule**. This is NOT an atomic molecule, but is a different word altogether that is also known as a **polymer molecule** to place a clear distinction on the fact it is not a normal fermion-atomic substance. A polymer molecule literally cannot decompose, which is why it isn't listed as having any half-life. There is no half-life, as it is an eternal being. While they are in solid form, they are literally the smallest quantum “material” version of that solid that can be found, not containing quarks and muons or any other atomic structure.

THE TWO GREAT PYRAMIDS OF EGYPT

Mind blown yet? There's more.

As just covered, a single body of crystal, regardless of size, is the smallest atomic version of that material that is a polymorph that changes from one thing to another, from solid into water, into plastic, into metal, into gas and on the list goes into every other form of polycrystals. Even though there may be a trillion tiny individual crystals creating that overall stone, it is still a single molecule because when they come into direct bond with each other, they harmonize through *sympathetic harmonic resonance* which distributes their crystal lattice as a single "element" that is only assumed to be an atom, even if there has never been any empirical evidence to quantify that theory.

This is another way of stating how science understands pyroelectric crystals. Below is a picture of perhaps 100 macromolecules of crystals that can be up to almost 60 feet long and weigh 840,000 pounds **per molecule** (the little red things are people):



Cave of Crystals, Chihuahua, Mexico

Network covalent bonding refers to one mineral structure that is not sharing any molecules of its makeup with any other species other than static energy ions alone and every occurrence or example of that material is in fact a single molecule of its own kind. So while a normal rock or tree trunk of the same size might have trillions of trillions of molecules inside, the stone that takes the shape of what it chooses to be at that moment, from lighter-than-air gas to heavier than water liquid, from solid to flexible plastic, has just one. All it does is collect, store, and then share energy packets that carry with them the record of events in any form from data to audio to moving picture films, or just in raw energy alone, your choice. All you have to do is tell it which form of energy you want it to dispense.

THE TWO GREAT PYRAMIDS OF EGYPT

This is to further establish the fact that when you are dealing with certain species of crystals, you are no longer dealing with stones, you are dealing with multidimensional, living entities (aether collective) and this is clearly understood and exploited by science. They know these are beings, and they know the geometric shapes (letters) of cellular language, as shared previously in this biomicrochip (human implant chip) below. Unless the shape of pyramids all assembled into six ultrasonic sound chambers with thousands of flat planar surfaces has something to do with asking these essences for more energy, and that pattern is a known symbol of cellular language, then there would be absolutely *no reason* for this nano-sized chip to be in a never-ending nested set of those pyramid cluster hexagrams;



Cheops SPOKE Pt 2

All of that energy is secretly known to science as oxygen as spelled out by the fact that the quartz silica used in all computers as the “thinking brain” is literally known as SiO_2 which stands for one part silica and 2 parts oxygen. Further established immediately above in the Wikipedia explanation of *Covalent bonding* is that the electrons (ions) that come together in pairs create a “hard shell” around them which is in fact *silica*. So it is not the silica that is producing that oxygen, it is the oxygen that is producing the silica and one cannot exist without the other. Silica without oxygen is factually known as *amorphous* glass that is missing its *long range order* which is code word for sentence which is code word for oxygen:

*Wikipedia: **Amorphous solid**;*

*“In condensed matter physics and materials science, an amorphous (from the Greek a, without, morphé, shape, form) or non-crystalline solid is a solid that lacks the **long-range order** that is characteristic of a crystal.the term has been used synonymously with **glass**.”*

The wires in that motherboard are stripped of all oxygen in its outside band in order to move oxygen through the surface of the metal, then back into crystals once again where that oxygen energy that is Sentient and performing every single calculation within that computer can be asked to perform another computation, then another then another. And the only place where oxygen can be found is carried in piezoelectric, vibrating crystals such as the Aniline microcrystals carried in the “air” which is always surrounded by at least a thin layer of water as insulation.

THE TWO GREAT PYRAMIDS OF EGYPT

In case you still do not believe that these fully-aware, Sentient crystals are secretly oxygen wrapped in living material (silica), then perhaps we will allow science to explain it further. Remember, the word atom is strictly being exchanged for **covalently-bonded ions** that are energy alone, not atomic fermion matter:

*Wikipedia: **Quartz**;*

*“Quartz is a mineral composed of silicon and **oxygen atoms** in a continuous framework of SiO₄ silicon–oxygen tetrahedra, with each oxygen being shared between two tetrahedral [double **pyramid** crystal lattice], giving an overall chemical formula of SiO₂.”*

Then there is the crystal known as magnetite we have touched on already about a hundred times, which literally lives and dies by oxygen (Aniline) alone. While it may still be full of anion ions, if it is absolutely sealed off from oxygen, it literally cannot even grow:

*Wikipedia: **Magnetite**;*

*“Magnetite contains both ferrous and ferric iron, **requiring environments containing intermediate levels of oxygen availability to form.**”*

ELECTROSTATIC INVERSION

Cheops SPOKE Pt 2

Inversion in electrical science is when static energy is transferred into electron movement (electromagnetic) when coming into contact with a conductor such as iron, copper or other form of metallic conductor. When this transfer happens, it creates heat. The heat elevates the temperature of dielectric materials such as crystals, silica or ions which are actually microscopic crystals. Such dielectric materials fundamentally resist a magnetic field, therefore they resist electron flow instead of readily acting as a conductor. However, when they are heated, their resistance decreases. If they heat up enough, this causes *electric* or *dielectric breakdown*, which then allows for the release of the spark into the open air (or to another conductor, etc.) as you saw previously in the Tesla Coil image.

The only reason the Tesla Coil produces this visible display is due to the top torus ring being made out of metal. If the ring were made out of let's say granite or silicon, there would be no breakdown in the air, so there would be no transfer of Dark Matter momentarily that could be seen with the eye. Yet the invisible torus field that would surround that *dielectric* torus ring would still transfer charged ions into the air just the same. The difference is there wouldn't be any danger while doing so, because there wouldn't be any **open-air** secondary emissions. And "open air" is really just a way of saying that the water that is insulating those ions away from the electrons has been totally evaporated out of that space, allowing the transfer.

In the Tesla Coil instance, the electrode that sends the sparks out into the air is concentric, so the sparks are

THE TWO GREAT PYRAMIDS OF EGYPT

deflected into every possible direction during the Dark Matter emission. If that torus were a cone, reducing down to a single pointed tip, then the energy would flow only from that point, not from the rest of the metal surface, because electricity while reducing down into a cone follows the circumference of the cone. This is true with all electrical flow. The core of a copper wire isn't moving any electrons, only the outer-most edge of the wire does. As the flow of energy follows down into a single tip, then all the energy tries to crowd itself at that pin-point to release. Since they are spiraling once they arrive, they will then follow a spiral once they emit into the air. This accelerates the speed by which the ions flow, just like a garden hose nozzle, forcing them to travel further, rather than diffused.

Knowing something about the power of pyramid shapes and about Tesla coils (which are **double oscillating frequency** electromagnetic generators), *Dr. Dee J. Nelson* created a model of the combination of the two. He placed a Tesla coil inside of a model pyramid, then used a metal pyramidion at the top, which was made of a conductive material (copper). Turning it on, they were able to take a Kirlian image of the energy that emanated from the pyramidion (electrode). The two phases of energy generated by the Coil emitted into the top of the pyramid, then the pyramidion condensed them each down to a single pin-point at the top. What came out was now a double-helix of concentrated energy that was made up of two different frequencies that were in the same scale to each other, so they harmonized and formed into this dual-spiraling double wave:



To my knowledge, the photo above has not been graphically altered other than in contrast for color enhancement. What emits from the square cone pyramids is not wild, out of control random bolts, but attuned, dual rotating focused beams. In the actual pyramids, these were meant to reach the highest level of the troposphere and ionize all the particles above from the top-down.

This is because positively-charged ions (ions now in cation-state) continually travel downward toward Urth from the thin-air levels above clouds, just like cold air always seeks the lowest possible level. The freezing atmosphere of thin-air elevations is cold because the positively charged (empty gas tank) ions are missing energy packets, so they are unable to cast off the heat that negatively charged ions do

THE TWO GREAT PYRAMIDS OF EGYPT

(such as down in valleys and at sea level). The Energy Temples weren't just ionizing the air directly over the top of the pyramids themselves, but were ionizing the entire sky from Urth upwards then scattering off of the dome. And doing so with a pulsating, dual-phase directed energy Saser beam. Yes, they really are that powerful.

CONTROL TEMPLES

Realize that the Global Cold Fusion Energy Temple Network is made up of many thousands of these cone-shaped structures that harvested static electricity from the Deuterium aqueduct "rivers" that flowed beneath each *Control Temple* (such as Cheops). Control Temples are the largest structure within an Energy Temple complex, which includes multiple smaller temples within its immediate field that receive, amplify and rebroadcast the waves. In Giza, there are four *Transponder Temples* of Cheops. The smaller Temples are not initiating energy flow, but are merely transponders for the Control Temple which begins the energy production. While they do amplify and rebroadcast the ions from the Control Temple, they don't use Deuterium to jump-start the grid. There are tens of thousands of Transponder Temples within the network.

Such Control Temples are always situated over underground heavy-water rivers, sometimes called lakes or wells, but are known as *hydroducts*. Each one of these heavy-water hydroducts follows the exact Urth-energy

Cheops SPOKE Pt 2

geodesic pattern, from one subterranean Krystal Cathedral Temple to the next which are known as *cross-ley lines*. The piezoelectric energy emanating up through these points is much more powerful than any other points on Urth, meaning that both the water is supercharged (Deuterium), and the Urth's sonic resonance is supercharged at these placements. Cheops was built over both of course. While Cheops is linked to the underground hydroduct, you will find that its four support transponders within his one complex are not (the other Control Temples at the Giza Complex will be addressed later under RADIANT ENERGY HARVESTING TRANSPONDER TEMPLES). The primary Temple's link is all that is needed to begin the flow of energy, so the extra labor to create such subterranean excavations would have been simply superfluous. Energy set into motion remains in motion.

Control Temples, such as *Kukulkan* in Chichen Itza, Mexico have also been shown to be directly over such hydroducts. In fact the city of "*Chichen Itza*" was actually named after Kukulkan's underground well which translates "*at the well of the itza*". Itza translates to "enchanted", so Chichen Itza is literally: "*at the well of **enchanted** water*":

THE TWO GREAT PYRAMIDS OF EGYPT

**Tridimensional
electrical
tomography
underground
lake below
Kukulcan**

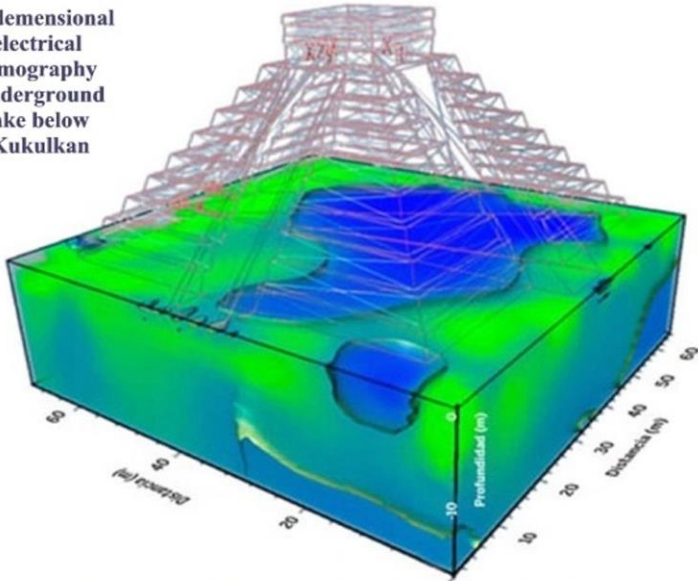

TEMPLE KUKULKAN PYRAMID CHICHEN ITZA

The Temple complex of Kukulcan shows a number of Transponder Temples surrounding that Control Temple, exactly as seen in the Giza Plateau:

Cheops SPOKE Pt 2



The water's function isn't that different than the way solar panels bring in roughly 1.5 volts of photon energy from solar waves per cell, then through a process of sonic acceleration, the Temple steps up that energy for ion release. Rather than merely using photons direct from the sun's waves, Control Temples also use *Static Electrical Transfer* (S.E.T.) to harvest energy from the Deuterons in the heavy water as their beginning energy. The S.E.T. process is comprehensively explained in previous chapters in volumes 1 and 2. How Cheops and the rest of the Control Temples access that energy will be covered here.

A similar process of harvesting vast amounts of energy was created by Nikola Tesla in 1901 in the building of the *Wardenclyffe Tower* in Shoreham, New York;

THE TWO GREAT PYRAMIDS OF EGYPT

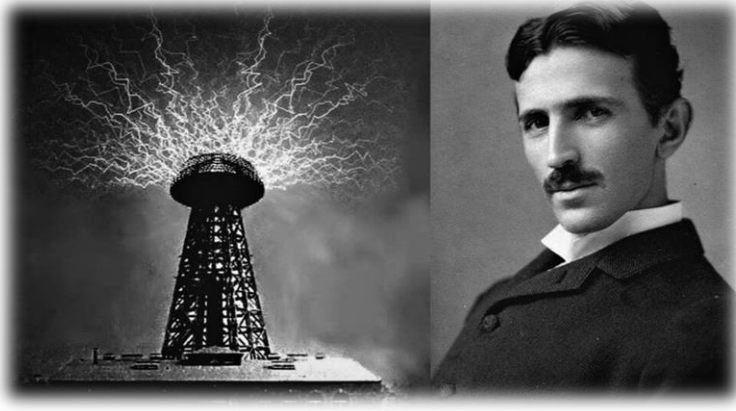

In the image we will be getting to soon, taken directly from Wikipedia regarding the Great Pyramid of Giza, you see that the outline of the structure included a descending staircase below the pyramid. There would be no reason to have gone through the trouble of excavating this passageway unless it had something to do with that project. Indeed it did, since the rest of the project would have failed to begin the ultrasonic process without this source of power prior.

Just as importantly is the fact that in order to begin the energy production shown here, a solidly grounded connection to Urth must be made to fully take advantage of the multiple forms of energy that are available directly over cross ley lines as we have already briefly touched on. Not least of which some 7 miles directly below this precise location is a piezoelectric energy plant the size of a city made up of crystals as tall as skyscrapers, emanating

Cheops SPOKE Pt 2

massive waves of ions up through the mantle and right through the Deuterium water below the pyramid.

These Deuterium hydroducts that Control Temples are built over are channeled by limestone formed by marine organisms whose calcium shells become supersaturated by the cation ions carried in Deuterium, leaving the limestone incredibly *piezoelectric*, as well as incredibly *dielectric* and *paramagnetic* as we will go into a bit later. Deuterium is the carrier of the ions that are passed around within Urth's atmosphere from the neutrinos delivered in the sun's invisible waves as we have already covered.

The weight of heavy water (as covered in previous volumes) comes from its massive saturation of liquid crystals (millions of microscopic crystals within a liquid) called salt and hidden in the term Deuterated Reagents packed in "ether" (Deuterium) and even more secretly called Aniline you recall are the "batteries" that carry the ions on up into the atmosphere. Due to this enormous concentration of energy, the resulting limestone created by the super-piezoelectric marine micro-organisms that thrive in Deuterium is a perfect insulator to carry the hyper-volatile heavy water safely while so filled with cation ions ("dry sponges" for photosynthesis and anion ions) that exposing it to sunlight in pure form you recall causes it to explode.

THE TWO GREAT PYRAMIDS OF EGYPT

Such are the hydroducts below the location of Wardencllyffe Tower. Tesla didn't choose this location because it was pleasant or an especially good deal; he chose it because it was situated directly over Deuterium channeled in by hyper piezoelectric limestone. Interestingly, it was also positioned right over a **cross ley** line of the subterranean Krystal Cathedral Energy Temple in Shoreham, N.Y.:



Nuclear power plants are also positioned over such Krystal Temples, as well as over the Deuterium hydroducts because they are simply unable to operate without Deuterium and the intense frequencies generated by the Crystal Cathedrals. Here is a **Google Maps** screen save of the location of Wardencllyffe Tower at the end of Tesla Street, less than 2 ½ miles away from the *Shoreham nuclear power plant*:

Cheops SPOKE Pt 2

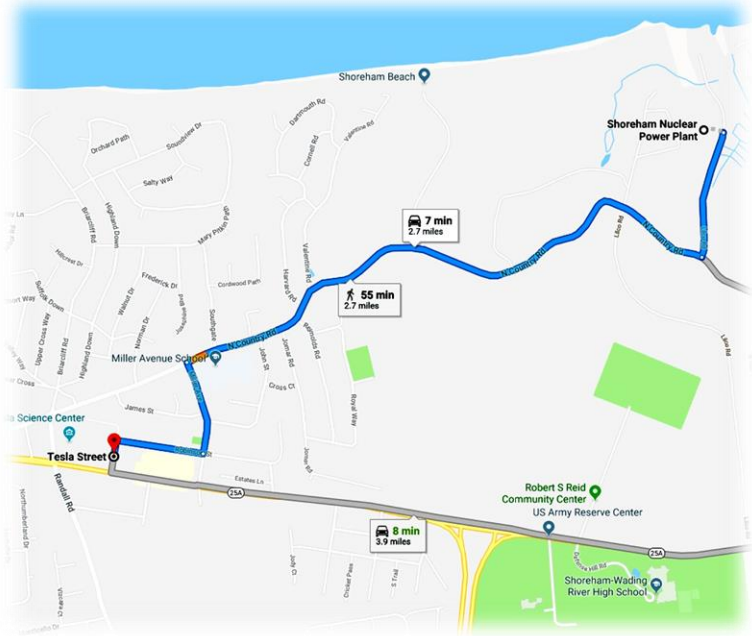

Below is a schematic of the front view of Cheops (missing is a second shaft that travels vertically down to the water, which we will cover later. For now, realize that under this pyramid is a stepped-vertical shaft in addition to the angled-passage to this area):

THE TWO GREAT PYRAMIDS OF EGYPT

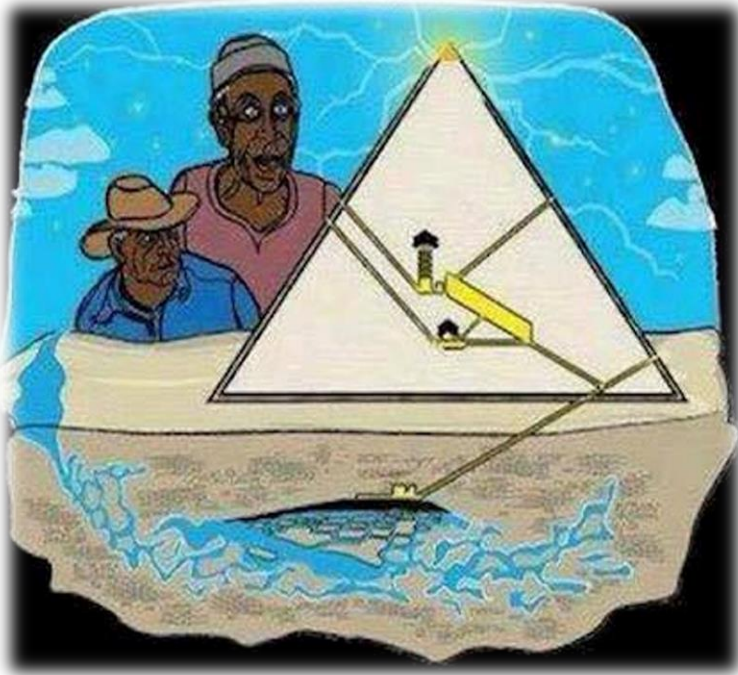

DEUTERIUM HYDRODUCTS

As you have just seen, there is a water hydroduct beneath Cheops, where the “*unfinished subterranean chamber*” is located, better known as the bottom of the *Osiris Shaft*. It is thought to connect to the Nile river. While it does connect to the Nile, that is not the source we are referring to, as the water below Cheops is clearly not freshwater. The waste water from the underground Deuterium reservoir was directed into this channel as merely excess produced by the other systems in place to power the Temple. The actual reservoir has been shown to have high salination levels as reported by **Dr. Kathy J. Forte** who smuggled samples out

to personally have tested early in 2018, since there was a “strange white filmy substance on the water”. Moreover, she had this to report:

*Kathy J. Forte: **Exploring the Great Pyramid’s Underground Water Tunnels;***

“The energy down there feels electrified, the air even feels cleaner.

....my inside sources reveal it to be anything but a tomb. My magnetometer had a higher reading than the norm, suggesting something else entirely.

*As I crouched down to obtain my samples, my Mena House hotel key card literally leapt out of my backpack. Instead of falling by my feet as physics would allow, the card bizarrely flew out across a short span of water and **onto the top of the stone sarcophagus.***

*The tests showed something I hadn’t expected. The Water Report showed **highest concentrate of sodium**, followed by chloride. The percentages displayed a sodium level which is higher than the fresh water of the Nile River, and lower than the salinity of the Mediterranean Sea, which the Nile flows into.”*

THE TWO GREAT PYRAMIDS OF EGYPT



Water from the Nile was in fact connected to Cheops through shafts to the close-by river, but the presence of Deuterium was paramount to the original engineers of the Temple, as you will soon see.

At the bottom of the vertical shaft leading down to the hydroduct that Dr. Zahi Hawass claims to be the Tomb of Osiris, yet the “sarcophagus” with the bottom section still immersed in the blue-tinted water as shown above was actually **empty** as reported by the man who discovered the lid to the box on the 3rd level in 1997, *Ray Grasse* in his account *Uncovering the Lost Tomb of Osiris*. Somehow, since its discovery and subsequent removal of mud and replacing the lid that had been dragged away to one end of the room, it is now well reported to have been found with skeletal remains supposedly those of Osiris himself. Almost as if the Egyptian tourism board might have something to

Cheops SPOKE Pt 2

say about more lucrative histories associated with Giza discoveries being a better story:

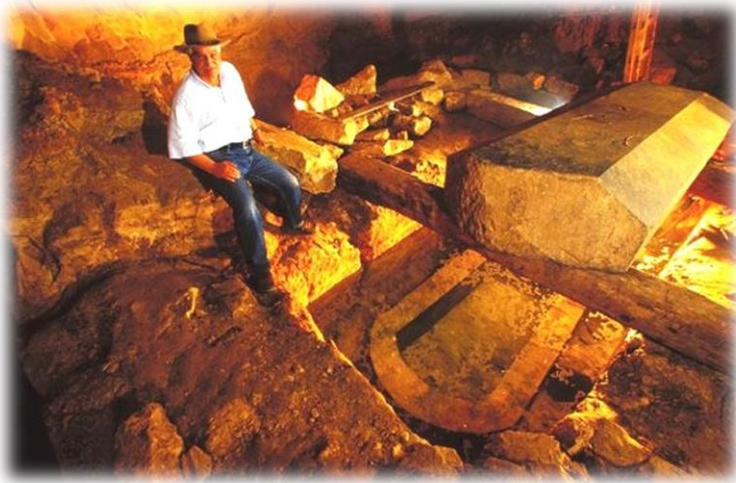

Here is a very rare photo of the underground lake that sits 98 feet below the surface beneath Cheops from the time prior to water levels receding as shown immediately above (which have since risen again currently as shown in the *Forté* image). Such early photos have been intensely guarded from the public since taken around 1997. The dimensions of this right-angled chamber is almost perfectly square around the base, but the ceiling is very deliberately angled as you can clearly see which has to do with directing both the gas and the harmonics generated in this room toward the sonic ducts we will be covering a bit later:

THE TWO GREAT PYRAMIDS OF EGYPT



Found in the center surrounding the “sarcophagus” originally were four pillars that once sat at the four corners of the room depicted here from this graphic, also courtesy of Dr. Kathy Forte’s website *trifinity8 dot com*. The pillars have since been removed (you will know why later):



While this is a nice graphic, what it assumes is that this was a room for some sort of ceremonial use; the pillars being architecture surrounding the sarcophagus of Osiris, creating a rectangular layout. As you see here, the actual dimensions and layout of the room is roughly of equal dimensions with the pillars in a perfectly square pattern. That isn't going to make much difference to anyone looking at this room as a ritual chamber, but it will to someone using it as a quantum megalithic energy device:

THE TWO GREAT PYRAMIDS OF EGYPT

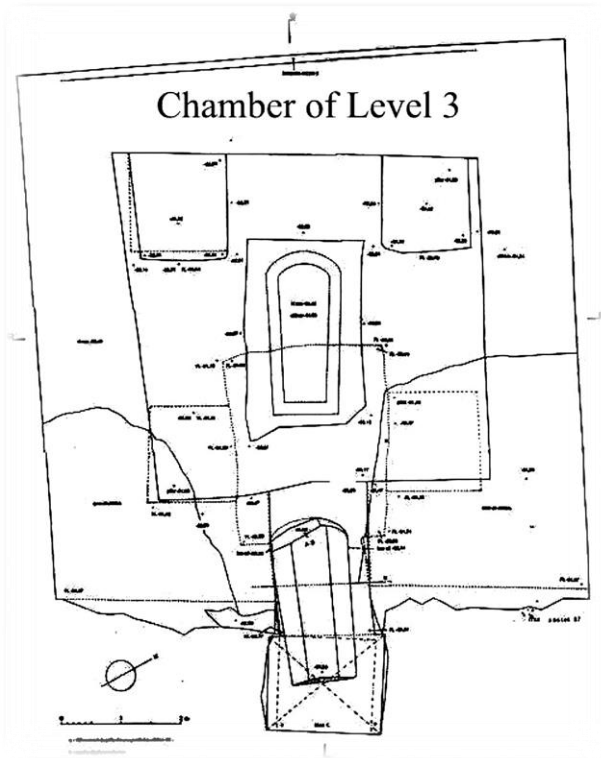

It is noted that the water in this room not only is blue-green, the same color as Deuterium, but also laboratory-tested to be salt water which turns regular water into an electrolyte solution. This electrified the air as reported by Forte as well as from other tourists noticing static electricity in the room as well as from the water. Not to mention that the “sarcophagus” in the middle of the room has factually been shown to be a powerful enough magnet to pull a hotel card -with a magnetic strip across the back-out of a backpack and across the water from where she was standing. Moreover, the entire room carved out of solid limestone had a moat excavated some meter deep all the way around the cavity at the center where the box lay

Cheops SPOKE Pt 2

perpetually immersed in water. This just so happens to be similar in construction to Atlantis as carefully defined by Plato, where there were rings of water separating the center from the land between the city and ocean. The only difference is this box had one ring, not two, and is in a square rather than concentric form. But since Atlantis was likely not generating its free energy from square waves, concentric would have been fine. Clearly neither one were burial chambers.

The graphic below was generated from ancient reports of the lost city of Atlantis:



If you were still under the assumption that this civilization was only a myth, Atlantis was in fact discovered years ago,

THE TWO GREAT PYRAMIDS OF EGYPT

identified precisely on all accounts down to the exact dimensions of the city, size of the concentric rings, geolocation, position among the surrounding mountains and unique colors of stones as reported in ancient historical documents that were for thousands of years considered mythology only because it had not yet been identified as a real place. This is because it was submersed under an ocean of water, erasing most of its recognizable features from the ground until eons of time later when those oceans receded, which now seems like desert to the naked eye from the ground. But from the air, there is no way to mistake its utterly unique construction as pointed out by **George S. Alexander** to be the *Eye of Africa*. You can find more at [VisitingAtlantis dot com](http://VisitingAtlantis.com):



Atlantis too, just so happened to use electrolytic salt water for its energy generation. Of the three walls that held in the

Cheops SPOKE Pt 2

moats, one was lined with brass, the next was lined with tin and the last was lined with “orichalcum” according to Plato in *Timaeus* which has been shown to be chalcopyrite which is a mixture of both copper and iron. All those waters were absolutely electric and served as the massive liquid battery that powered that capital city. Think of it as a 30 mile wide Baghdad Battery that would have supported tens of thousands of leads coming out of it to power all the homes.

WARDENCLYFFE TOWER

In Tesla’s Wardencllyffe Tower, Nikola built the sphere-capped, pyramidal-shaped tower above a subterranean river, with the cathode stretching down 120 feet below the surface. Roughly the same depth below as the hydroducts under both Kukulkan in Chechen Itza and Cheops:

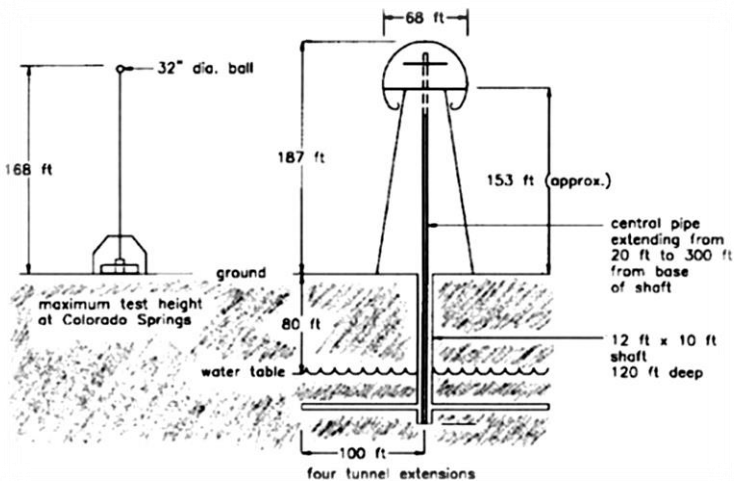

THE TWO GREAT PYRAMIDS OF EGYPT

In one of Tesla's schematics provided for the construction of the tower, he details how to construct the apparatus that would "connect to the Urth", or "plug in" to the planet like a wall socket. The drawing has now been annotated by sleuths seeking to unlock the mystery of the Tesla Tower:

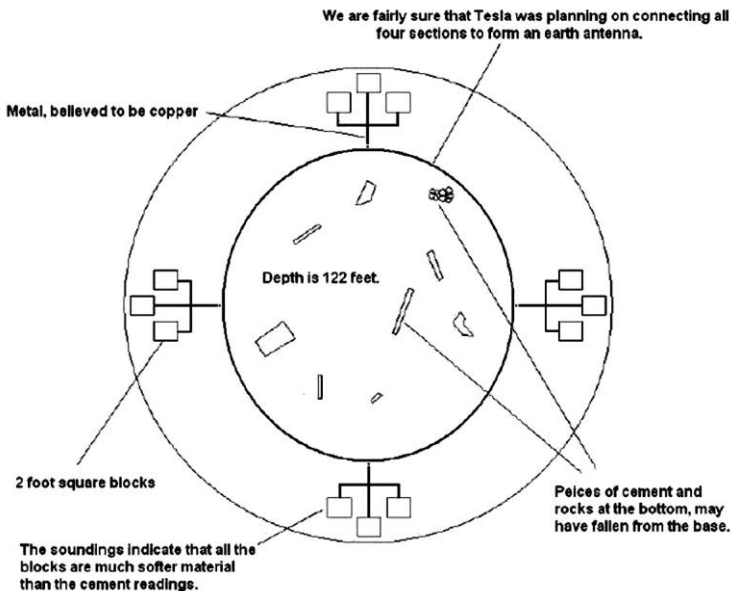

Within the notes it is clear that the tentacles of Tesla's "power plug" that was inserted into the water held 24-inch square concrete-like blocks in clusters of 3 at four opposing points. They go on to say that these blocks are much softer than the "cement and rocks" that was suspected to have "fallen into the well", apparently by accident. As if the manager of a project that would cost many millions of dollars to duplicate today would allow random pieces of

Cheops SPOKE Pt 2

junk to fall into its nerve-center and not be cleared out before the energy transfer was switched on. The “rocks and cement pieces” would have been made up of a precise combination of crystals that would vibrate at the right frequency to harmonize with the Deuterium in the well, and 2-foot square blocks were the conductors (that would be copper on the end of your power cord today), but in a composite molded stone that wouldn’t simply corrode and dissolve within a few years. This water is highly corrosive, as it is 2 parts salt and 1 part water (in the purest Deuterium pools).

NIKOLA TESLA FBI FILE

While Tesla’s intent from the very beginning was to give mankind the gift of free energy, the Tesla Tower was designed to allow huge volumes of radiation emissions as covered in the Tesla Coil section, which is more than likely why Wardenclyffe was never fully realized. This is evidenced by the mere fact that the tower was fitted with a metal cathode.

Little known is that Nikola Tesla was believed by the FBI to be an ambassador from one of the breakaway civilizations that reside below the surface in vast underground communities that have distanced themselves from the human evolution above who perpetually fall victim to their captors only to recycle again and again to surface Urth, never really growing or expanding in spiritual

THE TWO GREAT PYRAMIDS OF EGYPT

consciousness. This particular group who claims to have come from Venus long ago, and still refer to themselves as “Venusians”, sent Nikola to the surface in 1856 to bring free energy secrets to the human evolution so they wouldn’t wind up destroying the planet by soon attempting to install nuclear reactors (which happened anyway), which would also destroy their home as well (subterranean Urth, or Middle Urth).

It has been the standard modus operandi of the many various invader races, of which includes the Venusians, to present themselves as “visiting Urth from another planet”. This has been going on repeatedly for millions of years. But since this planet has been in absolute quarantine for eons, the actual truth is these descendants of the original invaders have been hiding below ground and protected by one surface-Urth Tara Cleanse after another, stretching back far prior to any recorded history still on planet but can clearly be seen in the sediment layers by geologists. All they do is travel to the surface in the same crafts they reside in, step out and then act like they just traveled a few million miles to get here. This is absurd. When humanity finally realizes they have fallen for this same grift through millions of lifetimes, I cannot imagine how embarrassed both they and the “Venusians” are going to be.

Below is the declassified document from the FBI that mentions Nikola Tesla’s provenance; which you can look up yourself online using the website url printed in the heading to see that once again they had claimed to have visited from space to bequeath mankind of this very special

Cheops SPOKE Pt 2

gift. Here's a secret, if they could actually get to space and out of this planet, they would. The invader races called "fallen angels" have been sealed into this plane since the Frequency Fence went up according to what I understand regarding their actual history:

FBI OFFICIAL RECORDS JULY 19, 1957 DECLASSIFIED 9/12/1992 NIKOLA TESLA A VENUSIAN

<https://vault.fbi.gov/nikola-tesla/Nikola%20Tesla%20Part%2003%20of%2003/view>

The screenshot shows the FBI Vault website interface. At the top, there is a navigation bar with the FBI logo and links for 'CONTACT US', 'ABOUT US', 'MOST WANTED', 'NEWS', 'STATS & SERVICES', 'SCAMS & SAFETY', 'JOBS', and 'FUN & GAMES'. Below this, the page title is 'FBI Records: The Vault'. The main content area displays a document titled 'Nikola Tesla Part 03 of 03'. A yellow arrow points to the document title. Below the title, there is a declassification stamp that reads: 'ALL INFORMATION CONTAINED HEREIN IS UNCLASSIFIED DATE 5-12-92 BY SP-6/AV/ML'. To the right of the stamp, there is handwritten text: '65-12890-1A/2nd'. Below the stamp, there is a typed report. A yellow highlight is drawn around the bottom portion of the report. The report text is as follows:

FILE NUMBER...
Date received...
From...
By name of...
To be returned...
Description:
2 page newsletter
RE 'MICA PLANETARY SESSION' NEWSLETTER'

machine invented by Tesla in 1938 for Interplanetary Communication. Tesla died in 1943 and his engineers did not build the Tesla set until after his death. It was placed in operation in 1950 and since that time the Tesla engineers have been in close touch with space ships. People have visited the Tesla engineers many times. The Space Tesla was a Venusian, and have told us that with Mr. and Mrs. Tesla in a remote mountain province in what is now Yugoslavia.

CHAPTER 16

QUANTUM ELECTRODYNAMICS

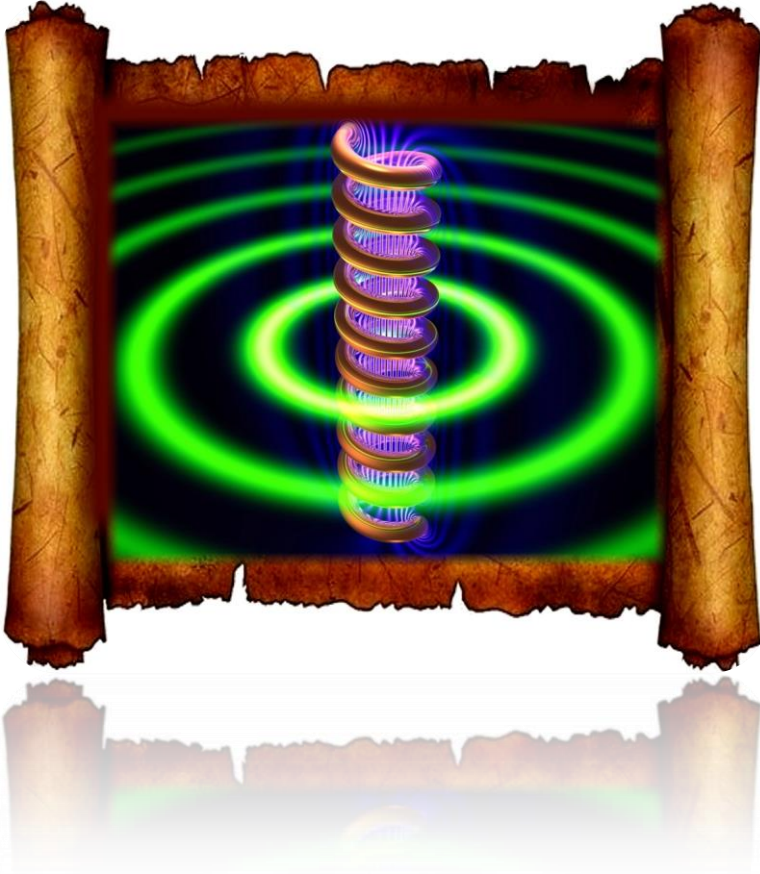

In this rather sciency section I am going to use terms and words that will be as easy to follow as I can possibly make them, as the technologies employed by the Energy Temples was brought to this planet from millions of years in the future and can get rather complex. It is my intent to re-establish the principles of ion energy production and it will

Cheops SPOKE Pt 2

be up to humanity to discard the programming they have been subject to in order to learn how clean energy works. It is eternally unlimited in volume, so there is nothing in your world that cannot be accomplished if you merely employ these principles.

To the physicists now reading this, you will either set aside your preconceived notions on how things must be referenced to fit the standard model or you will not gain any benefit from this disclosure. You have been brainwashed into believing that because you know all the proper terms and claimed explanations that have been handed to you regarding energy, you already know what is happening. And when it comes to Dark Matter energy, you certainly do know a great deal. But with Light Matter energy, this is another matter entirely.

You are here to learn what has been *hidden* from you. Your ego will prevent you from being able to hear and learn if you don't leave your education at the door. We are counting on you to restore the Temple Network which won't happen unless you can overcome this programming called the lie of Pi. Sure, you have much knowledge, but you don't understand what has never been shown to you, and moreover, deliberately hidden behind Command Signets that surround these elements that disconnect the synapses in your brain from firing properly when certain subjects are approached. Just like the Project Monarch victims of MK Ultra have trigger words that instantly disconnect them from their true self and into an alternate identity; you have also been programmed with trigger

THE TWO GREAT PYRAMIDS OF EGYPT

symbols and subjects that cause you to disassociate yourself from your intellectual mind when presented. You have learned a language you will need to unlearn and will have to try harder than anyone else is able to follow along.

And where that hidden programming lies is in the “mathematical equations” and symbols used to “explain” science to the rest of the world. In truth, this has always been a deeply complex maze where certain numbers lead to infinite non-answers, blocking you from reaching beyond those fuzzy limitations. Forget the math and look with your eyes at what you are seeing. This is empirical evidence, not little square boxes carved out of stone for you to draw your conclusions inside.

I will be using Standard Model and particle science explanations to help illustrate how things actually work so you can have some frame of reference to address these processes. Light Matter is very much connected hip and waist to the outside force of the aether that has been discredited and dismissed by nearly all avenues of science since Hermetic Alchemists insisted on the belief that mankind is the result of evolutionary coincidence alone, where there is no such thing as a god. This is because they were literally here to enslave gods (members of the actual god family), and if you ever figured out that it was your own essence that is behind the unexplainable, you would soon realize how you could easily overcome their grip. In order to take back your sovereignty and take back your position of creator gods, you will need to first realize that it was you who designed this planet and every single creature,

mineral and material to begin with. All you have to do now is remember.

LIGHT QUANTA

There is a term in the Standard Model of particle physics that allows scientists to let go of ancient understandings of how physics is supposed to be observed using antiquated *particle* beliefs and transition into a new way of describing wave phenomena called quanta, or *quantization*. “Particle form” is what material things exhibit to our natural senses. The things we can see, smell, touch, taste and hear; such as a building, spices or wind and rain. And physics until not long ago, relied solely on what was within the five senses as evidence of something real. The theory was that particles exist, or, that there are such things as “matter particles” at the core of all creation. That somewhere, down inside atoms, there was a speck of sand sitting there, proving we live inside of a material world, based on mass and matter.

However, when *Satyendra Bose* introduced *Planck's Law and the Hypothesis of Light Quanta*, it established an avenue where science could migrate from the outdated notion that matter is a real (non-holographic) thing, and into quantum observation where at the bottom of every atom was a light wave, not matter, and using their own terms and equations (or their own unique scientific lexicon of understanding). This transition is called quanta, which leads the new standard of science called quantum

THE TWO GREAT PYRAMIDS OF EGYPT

mechanics into researching the ‘quanta’ of the photon where there is no such thing as matter, material particles or generally anything we would normally be able to witness with our own physical senses at times.

Bose was able to explain in Standard Model particle-physics terms how his findings were factually accurate, and that matter simply doesn’t exist on any level below the naked eye where everything is actually a hologram, or expressions of light. Light can seem wet, hard, heavy, hot or cold, but in the end, it is always light and sound, not matter. The particles that were named after Bose, who happened to be an Indigo, are called *bosons*, as covered at length in volumes 1 and 2. Even though science still refers to bosons as particles today, it is well accepted that bosons are photons and they break all known laws of SM particle physics because they are not functioning within the *electromagnetic spectrum*.

The electromagnetic spectrum is a term to explain that something is *measurable*, or its energy can be weighed like apples on a pair of scales, calculating the *strength* of its magnetic attraction and repulsion, obviously like a magnet. Because all magnetic functions are energy, and energy is called electricity, we call this *electromagnetic electricity* to make the distinction that it is **not** static kinetic energy such as a boson or neutrino not playing by the rules. However, science readily admits that neutrinos and bosons must exist, so why is it that their actions are so vehemently argued against? And when you make another breakthrough that

Cheops SPOKE Pt 2

disproves the ramparts science stands on, why is it the scientific authorities refuse to publish it?

Of course you already know why by now; because as long as the highest authorities of academia refuse to accept it, that truth remains buried exactly where the real rulers of the world insist it be entombed. The hidden-from-view puppet masters and the ones you are allowed to see at the head of scientific circles may look human, and may seem human, but in reality they are merely taking on a temporary human form in order to preside *over* humans, and your learning the truth is *not* part of their agenda.

The counterpart of the electromagnetic energy spectrum is known as *quantum electrodynamics* where the weak force of photonic energy interacts with the electromagnetic spectrum through ions which carry electricity, but is regarded as extremely weak or faint, energetically-speaking, compared to the strong force of electromagnetic energy as ruled by magnetic pull. But magnetic pull that you can see with your eyes is only one level or manifestation of energy. It is the energy **BELOW** this energy that we will be covering largely from here on out. The energy that *imparts* magnetic attraction of metal and iron to magnetite.

While the neutrino is considered a fermion (what is considered part of an atom, or particles that are part of the material spectrum), it doesn't react with a magnetic field in

THE TWO GREAT PYRAMIDS OF EGYPT

the same way as molecules as we have already discussed at length, allowing the neutrino to pass through normal matter unimpeded.

Electromagnetic radio waves can't do this, as their magnetic fields are *cancelled out* by dielectric rocks and soil. This is why you see a metal shaft running to the water below the Wardencllyffe Tower, because Tesla was using electromagnetic energy, not phonon energy that could travel through solid objects wirelessly. This fact alone proves he was not planning on broadcasting ions, he was planning to broadcast weaponized electrons like 5G kill towers do.

The pyramids were originally designed to employ sonic photon energy, or static electricity, so you do not see a metal shaft running through the ground down to the waters below Cheops. The type of energy they used was ultrasonic frequency waves pushing electrostatic ions, and as you already know, there is no resistance to impede piezoelectricity traveling through a dielectric, paramagnetic structure under an applied magnetic field. Below Cheops you do not find regular soil and regular rocks that are electrostatic reluctant (resistant), you see solid piezoelectric limestone all the way from the pyramid's foundation to the water. This is not a coincidence. Soon we will see exactly how this all comes together.

GRAVITATIONAL WAVES

By the very name of Scalar *Vibrational* Mechanics alone that is the field by which creation is brought into form using genetic sequencing to achieve every nuance of a complex, material thing, you can tell that the foundations of all material manifestation sciences are based on vibration which is generated by sound. That sound is the snap or *click* of the first spark of energy that emits from a Sentient thought, as explained in volume one. The sound of that spark creates a rippling energy wave just like a stone tossed into a pond. Those waves move outward from the center point where the stone entered “reality” or the water, and commence telling the rest of the water droplets in all directions that “a stone has now created an action” and for all the rest of the pond to respond by sending that wave further and further across its surface so the rest of the water (the liquid silicate consciousness of god source we call the aether) *reflects* that fact.

How this wave propagates, whether it be light, sound, heat, electricity or any other energetic force, is the first “particle” that hearing the command, vibrates just like a tuning fork. When it does, it “bumps into” the next “particle which then vibrates and continues to pass the baton as already mentioned. Since the wave started at one point and was flowing outward, then the vibrations will continue moving away from that point, even though none of the particles ever actually travel anywhere.

THE TWO GREAT PYRAMIDS OF EGYPT

Probably the easiest way to explain how it works is like a human wave in a sports bleacher where one person raises their hands over their head, then another person to his right does the same, and the next person over picks up where the other left off. Suddenly the single wave started by one person is now enveloping the spectators from field to fence traveling around the entire stadium. But that first guy never left his own place where his seat was located. And the same thing occurs in every “pixel” within the spacetime fabric that science has identified as being “manned” by *bosons*:



Each human body sitting dormant above is acting exactly like a *Gauge boson* that “holds the coordinates” of each pixel (in this case, their seat), and when the wave reaches their pixel location, *a new spark triggers in their mind* that tells them to now wave their arms at just the right moment to propagate the wave that *powers* their “pixel”. That action

Cheops SPOKE Pt 2

is “the god particle” in science, or the ability of a Sentient thing to make a choice to do something at a precisely calculated time that cannot be mistaken for a random event. The Higgs Boson, or the *flavor* or *action* of that particle is the actual illumination of a color that appears within the spacetime fabric as viewed under electron microscopy that provides the “spark” that fills in that until-now “flat” pixel with visible light that now becomes a 3 dimensional, illuminated pixel exactly like the ones in your video screen.

The W (secretly Y) and Z gauge bosons stand post at the outside corners of each pixel as explained in volume 2 of this handbook series, that can be thought of landing-strip flag men telling the Higgs Boson which pixel needs to be illuminated at what time and with which color. Then, as if by magic, the Higgs Boson shows up to flash visible light right there where it falls into perfect order to propagate the wave, just like the next chaser light within a series that makes a store sign appear like the light is moving around the outside of that billboard.

This is the X coordinate that completes the 3 required portions of a cube, or the hidden equation that makes anything seem to have depth to what we see. Gauge bosons are known as Scalar bosons for this very reason, as they literally hold the vector coordinates at a precise point in “space” that can be measured and mapped by two different observers, so science is literally able to tell you which spacetime pixel is supposed to flash with mathematical precision once an event (command) is now in play, based

THE TWO GREAT PYRAMIDS OF EGYPT

on the action from any one “rock” (event) thrown into the pond.

The light has a precise color of course, and each color has a **corresponding gravitational field** that tells all the pixels close to it that a rock is now “striking a pond”. The pixels next to it respond by reflecting the color of light that would be next in their immediate vector (direction away from the event), which is also coded with its own synchronized gravitational field. The pixels below the point where the stone entered the water, flash the color of a rock that is apparently now sinking to the bottom of the pond.

Suddenly, there are now millions of Higgs Bosons all rushing in to change the light radiated by each pixel within the splash zone in accordance to the initial *event* which is known as the *command* that sets the chain reaction into motion.

It is important to mention here that Higgs Bosons are not magic genies all flying around to fill-in the colors to all these otherwise flat pixels. Each pixel within the spacetime fabric is another Sentient being that thinks and acts, just like you do. When it thinks, a spark occurs within that Aniline crystal in the exact color that now explains exactly how much “density” (magnitude, color, scent, etc.) that pixel is supposed to represent, telling the pixels (Sentient awareneses) around it what to do next. It is the spark of that aether particle’s thought that powers the fabric, just like it is the spark produced within the brain of each person sitting around the stadium that causes them to wave their hands and arms into the air to propagate the wave. In

Cheops SPOKE Pt 2

reality, there are no such things as Scalar Gauge bosons; they are all Higgs Bosons in the vernacular of Standard Model Physics.

As you know by now, when a vibration (action) is made, it creates a color. This is the color of B flat 57 octaves below middle C recorded from the Perseus black hole. Naturally the actual color of the sound wave seen here isn't coming through natural lens filters, but it simply demonstrates the point that each unique sound has a unique color:

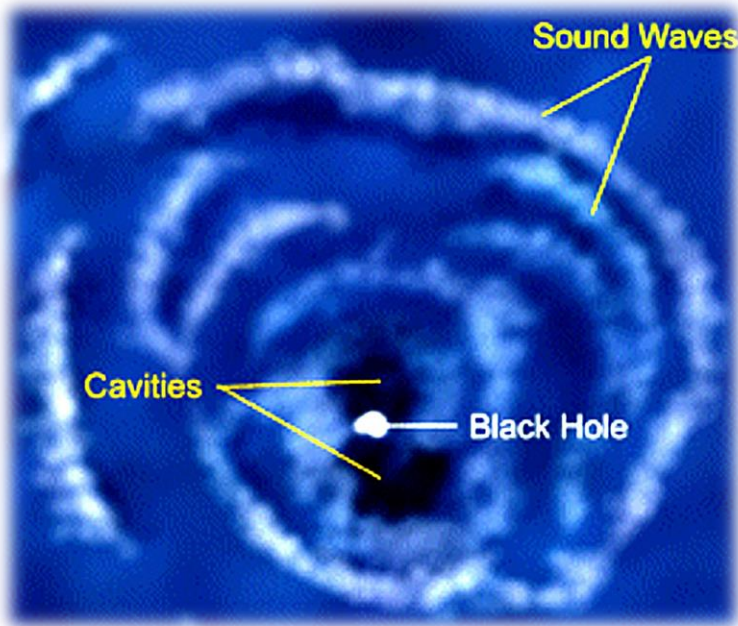

That color is a command in the cellular language of the aether and it has a corresponding geometric shape that can

THE TWO GREAT PYRAMIDS OF EGYPT

be printed on paper or a computer screen. As you already know, this is cymatics; where the energy behind the sonic wave prints out a pattern in water, with sand, or any other medium that can take the shape of the outline of the waves. Notice in the black hole image above how the signature of the wave literally forms a pattern as seen with a version of Kirlian spectrography used here. Also notice how this appears nearly identical to any one of the millions of vortex stone circles found in the mining fields of South Africa:

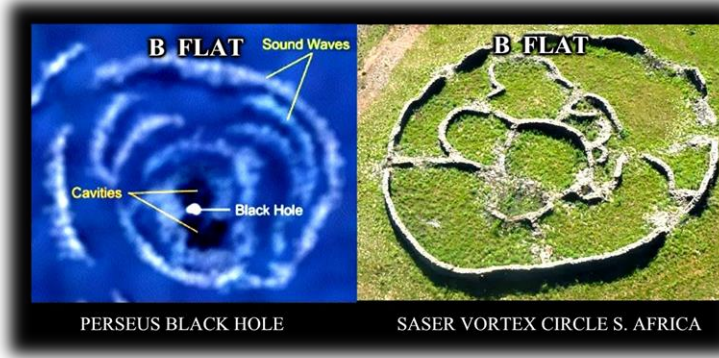

The reason they appear the same is because that Saser Vortex Energy generator is literally a physical black hole that is extracting energy from Urth at the frequency of B flat as we have just covered. On one side of a black hole is the energy source (Perseus in this example, feeds on space dust and neutrino raw energy particles it sucks in, then directs that utterly reconstituted energy into the Weasadek Phantom Matrix as a continuous “gas pump line” from the Gaia Time Matrix). What you can’t see, sitting behind “Perseus” is the actual Keylon Template that is positioned

Cheops SPOKE Pt 2

there that casts out the Command to generate the signal. On the other side is the “space” into which that energy is being transferred through the *Weasadek central sun*.

Our sun works in the exact same way and its pulsations (which are just as invisible as the Saser Circle above produces to the naked eye) are what feeds this planet. The same pattern printed out in the Kirlian image that was seen by the Sumerians on their video screen at the time of building this circle emanating from the ground looked exactly like the pattern they placed out in stone to amplify the vortex. If an aerial Kirlian ultrasonic cymatic image were taken over the stone circle on the right using an infrared lens, you would see the same pattern emanating upward in phonon waves that the circle pattern depicts.

The same cymatic unique shapes are used to print out an *equation* for a D-Wave quantum computer which uses geometric images inside *Qubit Spheres* instead of the letters you see in this sentence that are actually made up of a series of 1s and 0s behind your screen. That symbol, and the color as well as the sound or vibration, all have a specific **gravitational signature** that tells the aether how strongly (magnitude) that color is supposed to be affected by the push and pull of electromagnetic forces (either downward toward the huge electromagnetic “magnet” of Urth, or in an alternate direction if that **applied magnetic field** is stronger than the pull of Urth’s magnetic field. Once an aether wave has changed from neutrino form into a 3 dimensional ion form that is supposed to now act like a **visible** “particle” or thing, this is when science calls it an

THE TWO GREAT PYRAMIDS OF EGYPT

electron which is not exactly accurate, as you already know it is an ion until it has been inversed into Dark Matter.

I may have explained this over a dozen times already, but unless I explain it in many different ways, it is impossible for our minds to understand the process because not only does science hide these true meanings, but the symbols they use enforce the cognitive dissonance that washes over us when that subject arises.

*Only at the point where you now feel that subject has been made **irritatingly redundant** will you then finally “see” that true explanation. Until then it is only a theory the way the quantum reptilian brain functions.*

All actions within any holographic Time Matrix create the same “waves” that seem to *move through air* - which is also water - which we can then sense, measure and “weigh” physically now that the intent has been placed into *motion*. This command never dies, it never stops and it never fades. It is eternal. The rock may cease to sink when it hits the pond’s floor, but the **vibrations of that impact** simply enter into the pond floor, then down through the Urth’s mantle, out the other side of the planet and into space, all

Cheops SPOKE Pt 2

the while continually telling every pixel it comes into contact with on the way what just happened.

What science sees as “trillions of particles rushing away from Urth in every direction into space” as recently established formally by the scientific community proving that Urth is in fact “the center of the universe” after all, are actually the trillions of thought commands of each Sentient being taking material shape that is what creates what we think of as “universes in outer space” which are actually manifested, visible forms of our every thought. This is why “the universe is expanding” as reported by science.

Each pixel that hears the message also vibrates that message until every pixel within all 3rd dimensional creation knows the story about the rock and the pond. This is then recorded into all the silica particles of the planet which store it forever in what we call the *Akashic Records* where that initial impact vibration now adds itself to every previous vibration of every event that has ever taken place before on this sphere. And we do hear this symphony radiating from Urth’s core in the Schumann Resonance. This is why science emphatically states that energy can never actually die, but merely takes *different shapes and forms*, but never ends. Light beams never end. Energy waves never end. Laser beams never dim and they never stop. Because it is the expression of a *god* who put that wave into motion. And god (you), are the only family of beings in all of everything there is that has absolute control

THE TWO GREAT PYRAMIDS OF EGYPT

of the aether that *performs at the pleasure of god* (does its bidding).

Just like a candle waiting to be lit, stasis energy “packets” are the fuel that is used by the aether to power the next intent of god to come into “reality” through physical form. Once the spark lights the candle, the energy now changes from a solid, unlit candle, to a light now casting illumination across the room so that your material “eyes” can now “see” the reality of your intent before you inside the hologram. You can tell the stasis energy to “stand here” (let’s say in Denmark) and then cast your intent there, or you can tell it to “stand there” (let’s say 1 foot from where you are standing). It will make no difference to the aether, because stasis energy packets exist in every sub-quantum inch within all the *scripted* hologram (everywhere that the spacetime fabric has been mapped and therefore designated as “functioning space”), as explained previously in Chapter 20, eternally refreshed by neutrinos (all forms of bosons) that power the ions (all “matter” fermions) that power the projection.

This is why photon energy (“boson ions”) seem to be both in Los Angeles and in New York at the same time as illustrated previously in this installment under superconductors while in *Cooper Pairs*. ***Because “Cooper Pairing” is the act of placing ion energy and electron energy back into balanced photon form. Triplet spin state.*** While we have to go through the machinations under Scalar Vibrational Mechanics in order to gain a direct line of communication with the aether to tell it one thing or the

Cheops SPOKE Pt 2

other, it will function as we ask. But if we don't know how to talk to the aether (use the proper commands), it will remain right there in stasis until we finally learn that language, just like the candle remains merely wax and string until we learn how to generate the spark that turns it into illumination. And it has always been illumination that has been held back from this captive evolution, which explains why your captors refer to themselves as the *Illuminati*, or, the *illuminated ones*.

OSIRIS SHAFT

We are now about to go deeper into the Great Pyramid and reveal the secrets held back from you until this time. This can be considered the most advanced technological wonder on planet today. The science by which it functions can only be described as breathtaking, spectacular and beyond human comprehension. This is where you learn that the atomic composition of every molecule involved, from the bottom of the third chamber to the pin point of its pyramidion, Cheops was designed to use energy in its every form from bosons to both harmonized waves of manifest Light Matter and Dark Matter held in sound, water, minerals and air. Both the energy waves and the actual functioning device of Cheops itself are living entities just as conscious and aware as you have ever been.

The chambers leading down to the heavy water hydroduct under Cheops through the *Osiris Shaft* have been held off-

THE TWO GREAT PYRAMIDS OF EGYPT

limits to tourists until late 2017, when special by-appointment-only visits were allowed to commence. Each vertical shaft works its way closer to center underneath the pyramid. By the second level (just over the room at the hydroduct) is the first place where empty stone boxes are found briefly touched on a moment ago. From the tourism website *maestroviejo dot es*, we find a description of the shafts and chambers. Note the **words in bold**:

“Selim Hassan and his team were one of the first to explore the shaft in the 1930’s, but it wasn’t until 1999 when the structure was fully excavated by Zahi Hawass. By 1999 the water levels at the Giza plateau had lowered to the point that a detailed excavation was possible.”

Here is Selim Hassan’s description of the **Osiris Shaft**:

Selim Hassan’s 1933-34 Excavations Report For Giza

*“Upon the surface of the causeway, they first built a platform in the shape of a **mastaba**, using stones taken from the ruins of the covered corridor of the causeway. In the centre of this superstructure, they sank a shaft, which passed through the roof and floor of the subway running under the causeway to a depth of about 9.00 m. **At the bottom of this shaft is a rectangular chamber, in the floor of the eastern side of which is another shaft.** This descends about 14.00 m. and terminates in a spacious hall surrounded by **seven burial-chambers**, in each of which is a sarcophagus. Two*

Cheops SPOKE Pt 2

*of these sarcophagi, which are of **Basalt** and are monolithic, are so enormous that at first, we wondered if they contained the bodies of sacred bulls.”*

Note there are “seven sarcophagi” mentioned, yet there were only two large and two small boxes ever shown on the discovery maps, and only two, which remain today, have ever been produced. While the other missing sarcophagi may actually exist, it isn't of critical relevance, as they would each have contained crystals all tuned to the precise frequency of the photoelectric phase of their respective fields. The critical elements regarding the function of this stage within the Energy Temples would be the monolithic sized containers still present.

There are actually a total of eight chambers including the lower shaft at the eastern end of the room. One of the Black Basalt containers is visible to the far left of this image. It is a sharp-edged box (inside) in a sharp, and square-edged chamber as the rest of openings:

THE TWO GREAT PYRAMIDS OF EGYPT

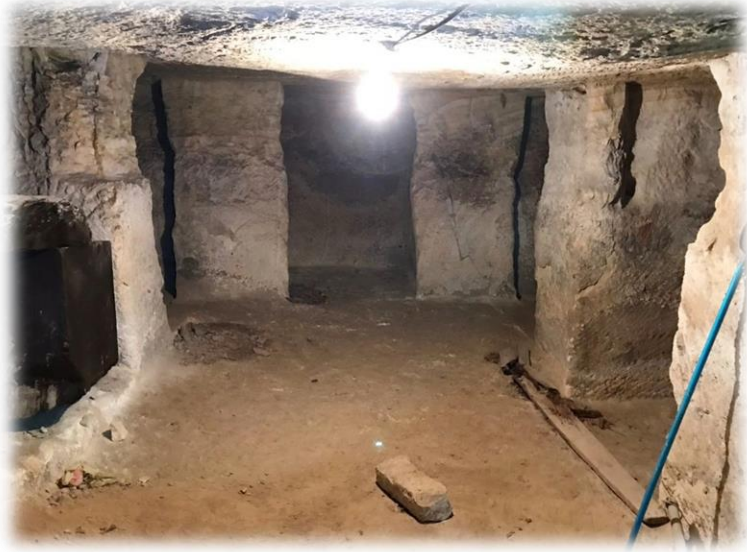

The “sarcophagus chambers” are at the bottom of Shaft B,
Level 2:

Cheops SPOKE Pt 2

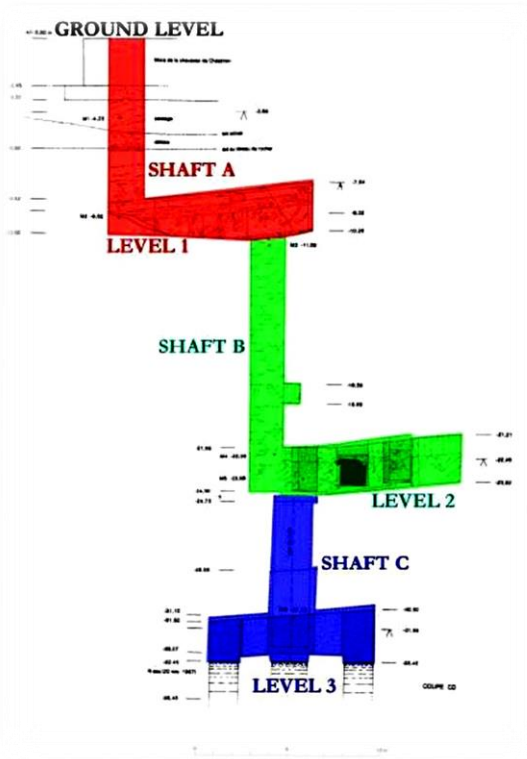

Now we are seeing for the first time, a layout of the actual placement of the seven chambers, and the lower shaft from an aerial view looking straight down. The chambers in red (below image) are all on the floor directly centered above the hydroduct at the bottom of the complex. Shaft B was explained by Salim Hassan's description as ending in one of the "**mastabas**" (corresponding to the level above shown in green). This is the word they use to describe a **burial chamber** (exactly like the rest within this room) and factually was never reported to have a sarcophagus inside. It only had "shards and debris" that had to be removed according to tedious explanation in the report, making his statement about the existence of all these other sarcophagi

THE TWO GREAT PYRAMIDS OF EGYPT

untrue for whatever reason he may have had. One small sarcophagus in chamber C and a misshapen stone of some kind in chamber E were both offset to the sides and are not present today, nor ever produced. So Shaft B is the seventh chamber he mentions. Shaft C leads down to the hydroduct room (Level 3), or the “tomb of Osiris” as shown in the original discovery image:

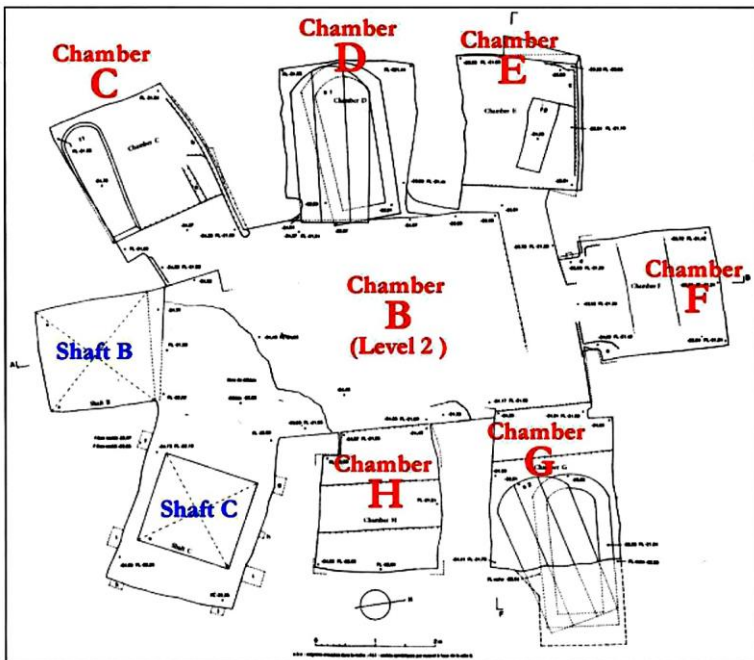

Take special note that the two huge boxes in these chambers are positioned one at the top center, and one at the bottom right, curiously a-symmetrically opposed from each other. There is a reason for this.

Cheops SPOKE Pt 2

The seven rooms and the second shaft in this view show a clear 8-point layout in equally-measured spacing from each other. Inside of the two empty boxes would have been tons of very specific types of crystals, immersed in what would likely have been tons of monoatomic gold powder, just as reported to have been found inside the empty box in the King's Chamber shown here with its original lid now-missing:

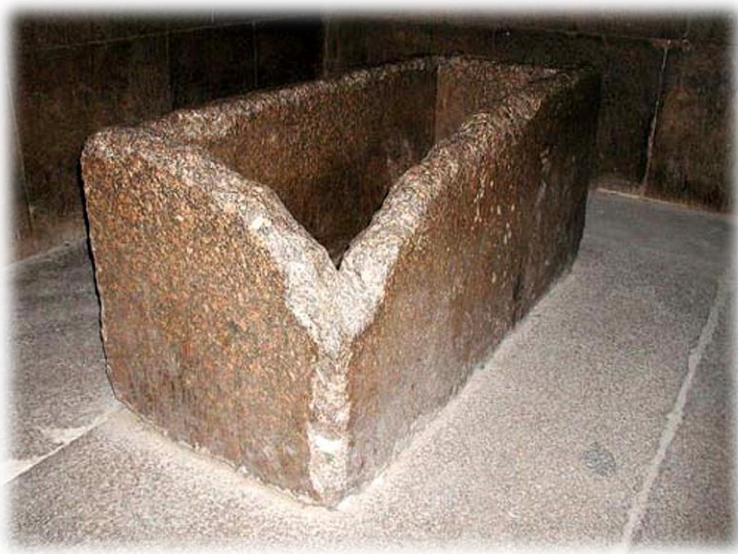

The type of geopolymer resin used to form all of the sarcophagi boxes would have been *Liquid Glass* in today's terminology that expands when it hardens, compressing everything inside by at least 0.1% as is required to apply constant pressure to piezoelectric stones in order to produce higher levels of static electricity. By compressing the dielectric, paramagnetic, piezoelectric material within the

THE TWO GREAT PYRAMIDS OF EGYPT

walls of these boxes would create an electrostatic magnetic field around each one, applying a concentrated energy field around the stones and powder inside, combining all their energies together in a single torus. Even without the additional crystals inside now looted by what would likely have been very unhappy tomb raiders, the empty sarcophagus in the hydroduct room still had a strong enough electrostatic magnetic field to attract the hotel card as reported in the DEUTERIUM HYDRODUCTS section.

The example below is known as *orgonite* that ionizes the air and used in healing applications and is not a snake-oil toy. The piezoelectric energy produced by this device can be read and measured with a spectrometer or with a negative ion counter, as well as other meters now available. The only reason they aren't already in every house today is they don't have a power cord running out of them to "prove" they actually work. That will remain the case until people begin learning that photonic energy can be measured as easily as electromagnetic energy:

Cheops SPOKE Pt 2



Here is a still of a corner of one of the giant boxes in one of the sonic chambers situated above the hydroduct room, grabbed from a video tour of the Osiris shaft. The perspective is taken from the lower left corner of the box that has been chipped from what had once been perfectly square:

THE TWO GREAT PYRAMIDS OF EGYPT



Note the appearance of this stone that it is incredibly similar to granite, made up of all sorts of different chunks of reflective crystal shards in its composition. This stone has been privately tested for its origin, revealing that it is not a type of stone that is anywhere within the Giza area, or in Egypt for that matter and in fact, it has yet to be identified as any known species of stone at all other than generally “Basalt” as an indication that it is made out of an unknown composition of diorite/dolerite. This is because it was a specially blended composite of stones to produce a resonance that would have been precisely tuned to the signal the generator was engineered to emit, and more than likely not found in any single quarry anywhere in the world.

Realize that diorite, dolerite and Basalt are species of trees, of which there were many around the world. And each tree had different unique fibers that carry unique abilities.

Cheops SPOKE Pt 2

Combining those fibers is the exact same thing as using different resistors, capacitors and semiconductors within a computer, just in their raw form. Remember, that in the quantum of these tree fibers are magnesium, palladium, iridium, osmium and the other extended noble metals that can be reduced down to a single-atom quantum powder, all of which come from Bismuth, which has already been shown to carry the highest possible piezoelectric energy at the same time as being literally made out of 52% graphene at its quantum core and powered by the frequencies of the sun by its magnesium. This is a self-powered black hole in literal, scientific terms.

The tour guide explains there had been an explosion of some strange type in both boxes, with now of course, nothing inside. The roof inside the chamber of one had been “liquefied” permanently black (this is not “soot”), and down the outside surfaces of the box also stained. However as already pointed out, that stone has been “goed” or glazed from ultra-intense atomic reconfiguration:

THE TWO GREAT PYRAMIDS OF EGYPT



I mention this only because according to David Hudson, the patent-holder of Orme, when monatomic gold is exposed to sunlight, it explodes, leaving nothing behind. Had the first tomb-raiders who opened the boxes used a torch to look inside, this may be responsible for all traces of the powder to be entirely missing now in the Osiris Shaft, leaving the evidence of intense surface glaze behind with no other damage, because a monoatomic gold ignition creates only intense light, not like a normal explosive concussion. Here is the ceiling above the one spot where the lid had been slid aside where the color does not rub off. This is an atomic reconfiguration:

Cheops SPOKE Pt 2



CHAPTER 17
THE TWO GREAT PYRAMIDS OF
EGYPT

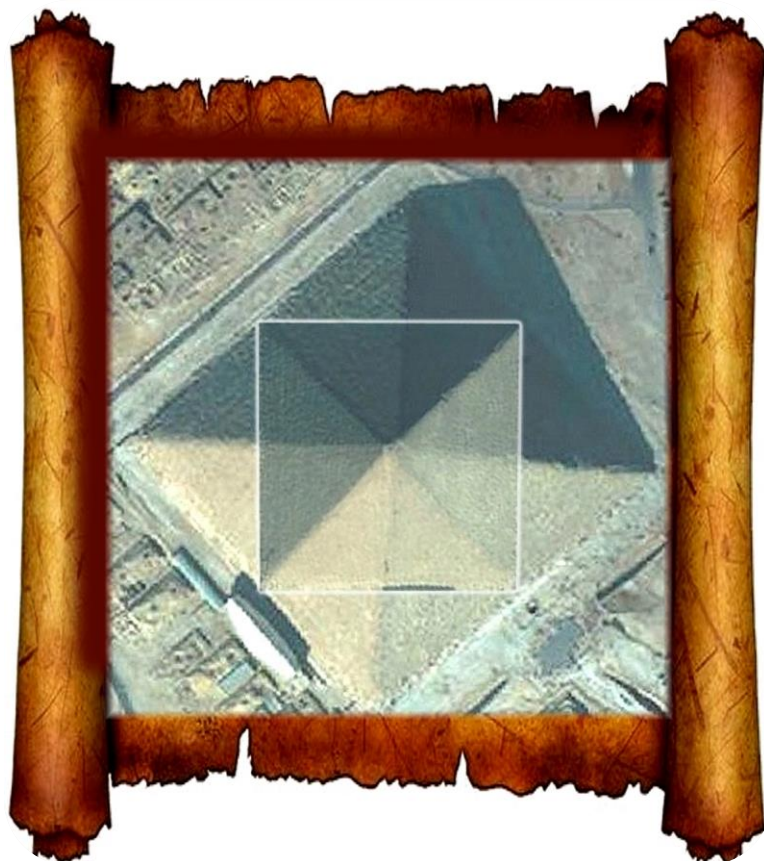

Cheops SPOKE Pt 2

The Great Pyramid is unique in that it doesn't have four sides as we find in the rest of the thousands of pyramids that have been found, but is actually the only known *eight-sided pyramid*. These indents cannot be seen readily from the ground, except for when the sun casts just the right angle of shadow across its face, but it is clearly seen from the air. This "indent" in the faces of Cheops are roughly a meter deep, or approximately 1 degree, a feat of subtle angle across such a vast span that would be considered nearly impossible to achieve as precisely as is found:



THE TWO SYNCHROTRONS OF CHEOPS

While this may seem like a mystery to anyone thinking that this was a tomb or grain silo, it isn't when you consider that this gives the structure eight sharp resonance points, the same number as a magnetron that creates such ultrasonic and powerful frequency that can be used to microwave food in seconds. While this form of energy in electromagnetic applications is incredibly harmful to biological life, in electrostatic, photonic form, is just as safe as a light beam dancing across a pond.

CAVITY MAGNETRONS

Direct energy (DC) Light Matter called **photoelectrons** is brought in to the core of a cavity magnetron through a highly conductive *cathode* wire. The DC current is then inverted into Dark Matter energy that is now moving negatively charged electrons into a conductive *anode* such as a copper hull with multiple sonic chambers which then amplifies that signal in a pulsating wave. This principle has been used for many decades inside what are called *electron tubes* (like the old vacuum tubes in a radio or TV before solid state came along). Each chamber generates an ultrasonic frequency that resonates with each other in either a *pulsating pyramid* or a **square wave**, combining this ultra-high vibration energy which is then sent out the top of the tube through a *waveguide photocathode*.

Cheops SPOKE Pt 2

Each chamber of the cavity magnetron amplifies the original energy exponentially through secondary emissions that causes warmer spots and colder spots within all the chambers. This heat disparity forces the free electrons to rush between each cylinder back and forth attempting to equally distribute the thermal radiation which causes a uniform **pulsation**. Each pulse forces the energy emitted in the direction of the magnetic field like a **sonic ram** producing a concussion.

It then travels through Dark Matter electromagnetic energy waves, delivering those frequencies to a resonant target. Magnetrons are what powers scalar radar waves that bounce off of a conductive material such as that of a fighter jet in the sky or a car traveling down the road. The particles that bounce back indicate the mass and speed of the target. They also generate such destructive thermal radiation they can be used to destroy the molecular structure of food in your microwave oven, producing hot, but nutritionally dead, food. These are also used in microwave ultrasonic Saser Cannons that can immediately form different varieties of cancers in a target that can lead to death in a matter of hours or days from pneumonia, heart failure and brain cancer to name a few. Each frequency of microwave cannons are tuned to target different biological organs specifically. My contact has been the victim of these cannon attacks more than a dozen times, always leading to emergency room visits and even lung surgery. This is pulsed, ultrasonic radio wave technology:

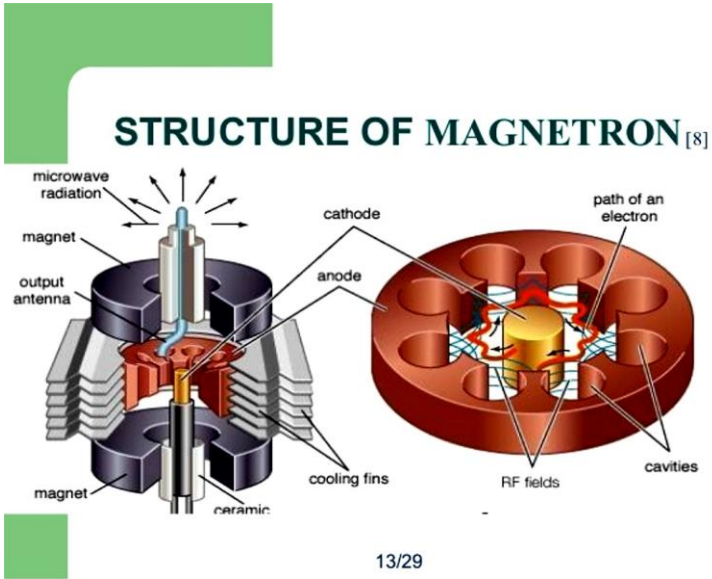

Here is another image of the *anode* (or body of the conductive material that makes up the *sonic resonance chamber*, in this case made out of copper):

Cheops SPOKE Pt 2

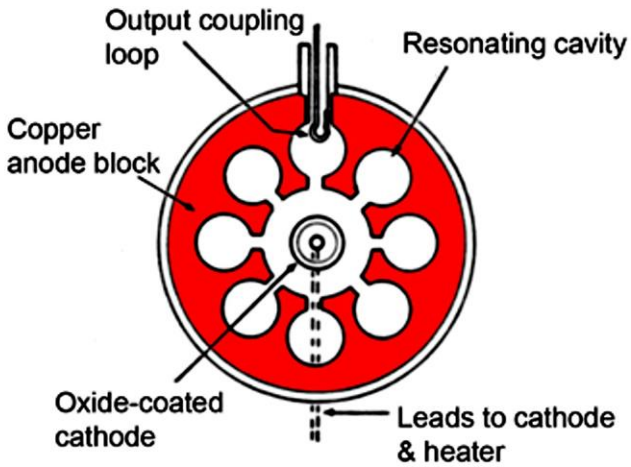

**Resonant cavity magnetron high-power
high-frequency oscillator**

Realize that insulated, dielectric magnetrons generate safe sonic waves that only produce ions as you take another look at the actual layout of the chambers inside the Osiris Shaft of Cheops:



Bear in mind that the Ultrasonic Energy Temples were deliberately built not in the standard cylindrical cone shape generally used in ultrasonic wave spectrography, but in a square-base configuration to perfectly harmonize with magnetite, which is the organic shape of magnetic energy. The base of a square pyramid is obviously square, while the tapered sides are obviously pyramids. The pillars inside the hydroduct chamber were square edged; the sarcophagus in the same room is square and/or sharp edged inside, the megalithic boxes in the burial chambers were square and/or sharp edged inside, the burial chamber rooms themselves

THE TWO SYNCHROTRONS OF CHEOPS

are entirely sharp square edges throughout, the King and Queen's chambers are square edged, the King's chamber sarcophagus is square edge inside and outside and the pyramid above also used square and sharp edged pyramid shapes to remain consistent with magnetron and synchrotron square waves as well as with magnetite, the quantum, perfect shape of magnetic force we will get deeper into as we go.

The inside edges of a sonic resonance chamber, as you will see when we get to the section coming up soon under **RESONANT INDUCTIVE COUPLERS** are just as important to be sharp angled from each other when dealing with ultrasonic sound chambers. Concentric shapes such as seen in cavity magnetrons can also work, but as you will see, this is outdated technology. A combination of arches and 90 degree angles with planar surfaces can produce higher-energy waves in more precision applications.

While concentric cones do work to squeeze energy into concentrated beams, square cones amplify the energy as well as compressing it into a much more powerful wave. Remember, magnetic energy is deposited into a magnet by ions **because it is bearing the physical symbols** of that Signet (signature). While magnetite may not generate a square wave without slight modification, everything about the Energy Temples is *based on* magnetic fields that speak in pulsation and rhythm that carry square-edged physical patterns on an oscilloscope. Here is that magnetite crystal once again, a tapered square pyramid:



The magnetron acts as an oscillator which produces a periodic, oscillating wave that differs from standard sinusoidal form, called a *square wave* as just mentioned. Also called a *relaxation oscillation*, it produces a wave that pulses between a high pitch and a low pitch in a precise rhythm, rather than simply beaming out one tone, which gives it either a triangular wave form, or a square wave form. In other words, the type of energy emitted by a **magnetron** takes the shape of an actual magnet that can be seen on an oscillation screen. A square wave typically comes in the form of a sound frequency that is equal-duration high and low frequency pulsations, which can look literally like a square, and when the pulsations are more frequent, it takes the shape of a triangle:

THE TWO SYNCHROTRONS OF CHEOPS

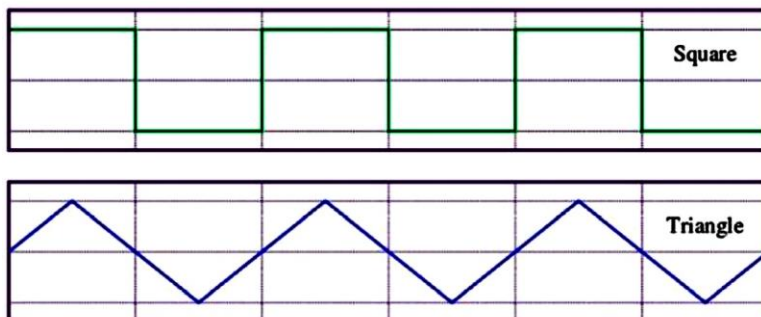

HYDROPHOBES

Of course, once you place a triangle on top of a square, you now have the actual shape of a magnetite crystal. Not a coincidence, since this crystal doesn't just accidentally grow in its geometrically-perfect equilateral shape. Pyramids could have been built cylindrical if it had been beneficial, but were obviously built rather in *square pyramids* (the term used in geometry to describe the actual shape of a pyramid). In a matured magnetite crystal you can see it takes on an octahedron form where both the top square pyramid and the bottom join at their bases, or the actual quantum shape of the crystals that produce the most optically-precise sphere as used in both electronics at its highest energetic signature, as well as in all optical applications to form a perfect "hydrophobe".

So in real terms, the shape you are seeing below is not only the quantum shape of graphene which is synonymous with black hole as an energy vacuum, but it is also the geometric

Cheops SPOKE Pt 2

equivalent to “flawless sphere”, as its blueprint in its toroidal field will generate around itself this shape once it has an applied magnetic field, whether that be water or “air” or simply energy. You recall now that this shape is known as a *cationic surfactant* in the quantum industry. So if Energy Temples are just one half of a cationic surfactant double-ended square cone, how can it become also both halves of the whole? Because as soon as the top portion of the pyramid generates a torus field, as long as the materials below are made of the right minerals, they now energetically mirror the shape of the top half of that projected sphere in perfect symmetry, again through network covalent bonding:

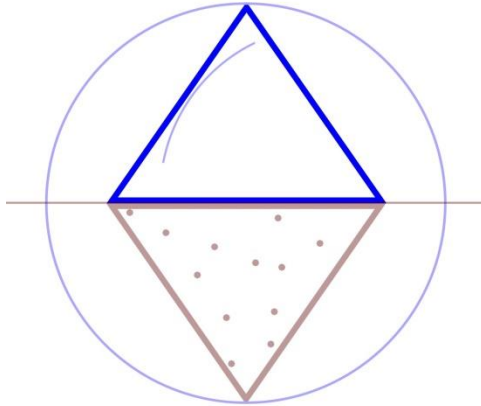

Of course, we are talking specifically about how Cheops operates in this paper, which is not actually perfectly square at the bottom, but is octagonal, which is more specifically, *two squares equilaterally nested*. Making two separate pyramids geometrically centered as a single, dual-staged

THE TWO SYNCHROTRONS OF CHEOPS

octagon with a dual-staged subterranean power plant below
(more on this in a moment):



Initially it will seem like this would be an impossibility for these nested pyramids to actually somehow “function” like two different devices since effectively this is nearly 100% solid stone throughout the entire construction. But what you can’t see is the fact that the inside pyramid was made with highly polished surfaces just like the outside pyramid was. At an atomic level this glaze is exactly like glass where the crystal lattice particles become suspended outside of the power of magnetic fields, causing the crystals to point in random directions, sealing in ions from passing through that barrier.

With the other side of that glazed surface 100% absent of light, it turns that surface into an absolute mirror to 3D photons, causing them to deflect, just like they do against flat planar surfaces. The wave moving in the inside

Cheops SPOKE Pt 2

pyramid is contained inside that one pyramid, while the wave from the outside pyramid is following the outside edge of those glazed walls at a perfect 90 degree angle. That is why this structure is built to such precise geometric tolerances. This now forms two optical-precision octahedrons, or two perfect cationic surfactant atomic crystals that are nested inside each other. This nearly 900 ft tall device isn't just one quantum chiral superconductor, but two:

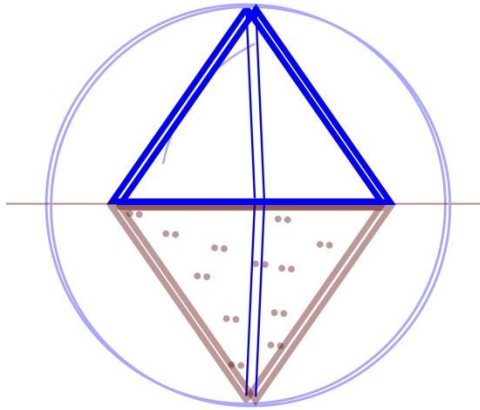

INFINITE VECTOR

Realize that we are just getting started with the technology applied in the Energy Temples that generates dual square wave signals processed through multiple Meissner Fields within the inside pyramid which would make it seem like both waves would be contained inside the one interior pyramid. Only due to the placement of the *synchrotron*

THE TWO SYNCHROTRONS OF CHEOPS

photocathode waveguide of the interior pyramid positioned at 45 degrees from its planar surface is the exterior wave able to pass through the mirror surface of the interior Temple.

I realize that this concept is more than just mentally daunting, but you have already gone through hundreds of pages of advanced particle physics by this point, so hang in there, because you have the foundation already lain to get there from here where suddenly a heap of rocks in a god forsaken wasteland just so happens to be an unthinkably advanced, multi-phased quantum physics no-man's land.

How energy can pass through an otherwise shielded surface is called the *infinite vector* in science, where stasis electricity, which is subatomic, can pass through another plane. At 90 degree angles, they crash and deflect, emitting secondary emissions. But at exactly 45 degrees, they are able to enter through the crystal lattice on a *tangent* that "pierces the glass mirror" of the inside pyramid. Only subatomic particles are able to do this, just like neutrinos. 3D "matter" such as active photoelectrons and sonic waves are limited to 3D physics. So the devices above use both atomic physics as well as subatomic physics in order to function.

When energy goes into a superconductive state (Cooper Paired), it transduces back into neutrino form, and while in that state it breaks through this boundary that would

normally repel that current. As you will soon see, at exactly the point where energy will need to pass through the wall of the inner pyramid in order to leap into the synchrotron of the outside pyramid, something beyond extraordinary happens within this monolithic energy device that produces what we call **cold fusion**.

You will come to learn what a “cold cathode” is and how certain chemical reactions generate ultraviolet wavelengths that only function using the material we now refer to as glass. The interior pyramid can be thought of as a giant glass bulb where energy now behaves inside like luminous ions we would call plasma and are able to make this leap. More on this incredibly exciting topic as we go.

PHOTOMULTIPLIER

A *photomultiplier* is a particularly inauspicious term for something that is as powerful as this device. It was originally developed to compound extremely-low light detectable within the *electromagnetic spectrum* (this is light that can be seen within the 3D world). It was first used in amplifying the tiny frames of picture images from a motion-picture film, and other equally as benign applications. Inside this photomultiplier were something called *dynodes* that took the first incredibly dim light (such as a single photon) and through a series of eight exponentially-increased steps, amplified it by a power of *one million times* the power of the single detected photon.

THE TWO SYNCHROTRONS OF CHEOPS

Well, that sounds like it might catch the attention of someone in the scientific community, doesn't it?

It did.

Albert Einstein used the dynode (the planar surfaces inside a photomultiplier) as the basis for the **foundation** of **Quantum Mechanics** in 1905, receiving the Noble Prize. Suddenly, the little dynode was employed in every walk of military and domestic applications from radio stations powered by *one million watts* to infrared telescopes, imaging technologies that could see through concrete and power spectroscopes that can view into the ultraviolet spectrum. Suddenly this tiny breakthrough in single-photon light amplification that rocked the world from the USA and Russia to the conclaves of Siberia somehow simply just vanished off the radar from mainstream news. Little wonder why.

So let's take a look at the insides of a photomultiplier. There are 8 plates that separate eight sonic resonance chambers inside (each curved dynode is another simplified magnetron chamber). The last plate, what appears as a ninth chamber on the right is the *out* anode, or the finished product. By this time it has compounded its signature by the electrons released from the **magnetic field** surrounding the tube, the energy is multiplied by 1,000,000x:

Cheops SPOKE Pt 2

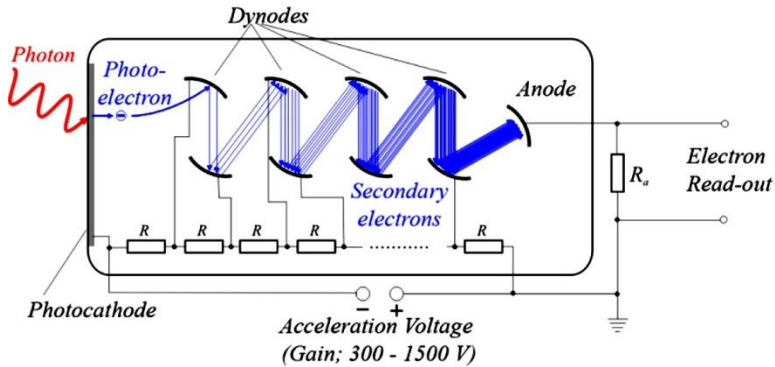

The photomultiplier above is the photon-ion version of an electromagnetic magnetron that is able to step up static electricity by a multiplier of one million times what it started out. This is only the energy it began with, or one single photon, so keep this in mind, as Cheops isn't working with a single photon's measure of energy, but innumerable times that. Photon energy isn't just found in light waves, but also any form of **static electricity**, such as piezoelectric energy from sound and also electrolytes in salinated water (salt water). This is because photons are at their core, sound. Static electricity at its core, is also sound. The only difference between *moving* sonic "phonon" energy and electromagnetic energy is the magnetic field around it alone. If you remove the magnet from the equation, then electrons flow without interference that notoriously siphons off energy every inch it travels.

In the case of the Great Pyramid, the energy signature that it starts out with is from the Deuterium heavy-water (pure photonic energy in liquid form) that is then amplified by the dual-phase induction generator within the hydroelectric

THE TWO SYNCHROTRONS OF CHEOPS

room and delivered upstairs by hydraulic ram pulsation. Once there, the eight dynodes of the two pyramids now amplify that signal by an additional one million times. So let's look at that process now.

SYNCHROTRON

While I have been using the term magnetron while describing the mechanism by which the Energy Temples function, and also showing how photomultipliers and dynodes work to increase energy by a factor of one million, it is important to note that how a particle accelerator functions is on the same principle of all of these devices.

The precise application of the technology has been adapted to study superballistic ultrasonic waves they call particles as they impact oncoming particles to see how they respond. The term particle instead of waves is used due to the fact that quantum science does understand that all waves are authored by a sentient being and then repeated by Aniline crystals which carry the heartbeat of that mission wave. So while there is no actual particle at the nucleus of the wave transponder, there is a tiny silica crystal surrounding it, and this is what they slam into each other to generate Light Matter at its most quantum level.

PARTICLE ACCELERATORS

Cheops SPOKE Pt 2

There are many particle accelerators, not just CERN. They know how Aniline crystals respond, and they have known about Higgs bosons for many decades. What they really do, in the case of the Large Hadron Collider, which is working in tandem with hundreds of others that have never been disclosed to the public, is generate energy vortices that can and do, place the entire planet and all of its residents into different timelines (interdimensions), constantly struggling to place themselves within a parallel reality where humans do not break free from their captivity and thus remain here in this Time Matrix through the end of the Stellar Activation Ascension Cycle now upon us.

*If they can succeed in this agenda, they are assured of having billions of slaves that are very easily controlled who will not be able to leave this dimension again, since this is the last ascension cycle for this planet. This is strictly behind the Mandela Effect that has swept the planet by storm over the last few years since the ascension gates opened. There are over **30,000 colliders** in operation today, many of which are part of the network that has been repeatedly changing our timelines since 2012.*

Since the application of ultrasonic wave acceleration has been brought to its modern-day technological peak, you

THE TWO SYNCHROTRONS OF CHEOPS

need to take a look for yourself what geometric configurations they have now taken while using the very special type of sinusoidal (sine) form of pulsed ultrasonic square waves as used in Cheops and the rest of the Network.

In the early years of particle accelerator development, the layout that was used was cylindrical, or the outside radius pattern that all sine waves take; concentric rings. As a *cyclotron* forces the waves down in a flat plane around an ever-shrinking, tighter concentric ring, like that of waves being forced through a cone, the particles generate secondary emission all along that path. However, over the years, this was abandoned by the technology known now as the *synchrotron*, the same geometry used at CERN. While the synchrotron complexes as seen from the sky do show a cylindrical pattern over these subterranean colliders, this is a red herring as seen with the *Soleil Synchrotron* shown below. Even though the actual collider beneath ground is in a totally different pattern, they still placed a perfectly concentric building over the top:

Cheops SPOKE Pt 2



Below the Urth, that pattern just so happens to be the same as the footprint of both the pyramids inside Cheops, turning all four corners of each tunnel into 8 total oscillation chambers which turn the whole operation into *dual synchrotrons*. These corners allow the generation of pure square waves to form while then crashing into the next dead-stop planar surface which amplifies the signal in an aggressively pronounced manner compared to the continuous gentle curves of the cyclotron. Both do the same basic things, but the synchrotron follows advanced technologies to achieve the most potent form of wave pattern that creates a sonic pulse. A cylindrical wave is a gentle, subtle energy. A square wave is like a sledge hammer delivering a compounding concussion with each impact that is more than *one million blows per second*.

THE TWO SYNCHROTRONS OF CHEOPS

The common graphic illustrations from CERN experiments always like to show a single tunnel that the tests are conducted in, but in reality, there are two. One produces a clockwise trajectory, while the other produces a counter-rotating vector; both in square-wave, pulsating form. In 1957, CERN utilized a “Synco-Cyclotron” configuration which is concentric, but in 1998, it adopted its current form known as a *Super Proton Synchrotron*. It too is always illustrated (for the public) as concentric even today on their website. But the fact is a synchrotron is defined by its shape, not its utterly unique function, as it relies on a certain pattern creating *boosting runways* for each secondary emissions using *linear acceleration* between each dynode (corner). Here is the pattern of an actual synchrotron:

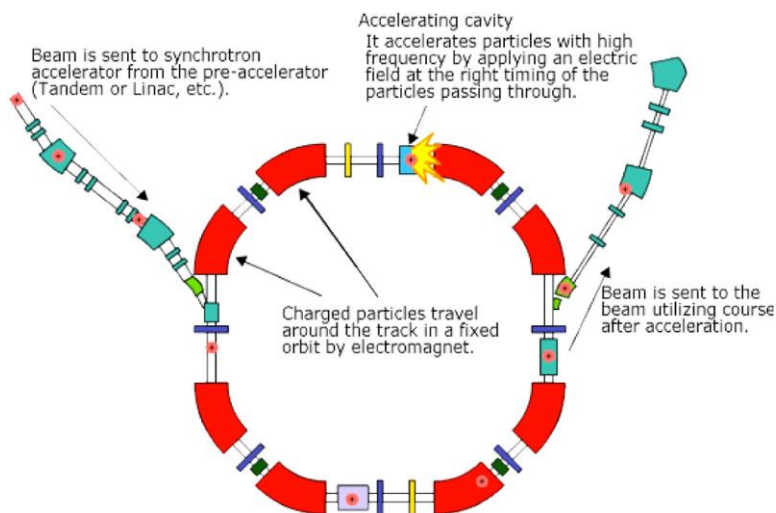

This acceleration, slamming into the next dynode and then acceleration again produces square concussion waves. The

Cheops SPOKE Pt 2

accelerators are known as *planar field undulators* that send the energy from the secondary emissions through a series of crystal capacitors that burst the trajectory of the wave toward the next dynode like a sonic ram, allowing for powerful and precise timing between each beat or pulsation that allows for *digital tuning* of that phonon wave. This is known as *subtractive synthesis* that harmonizes even with wind and air subtleties not achievable with solid instruments. In other words, a square wave is the most powerful, most definable wave type of sonic signature in the delivery of energy. Again, here is the actual pattern of synchrotrons. Note the very clear dual continuous chambers.

Soleil Synchrotron:

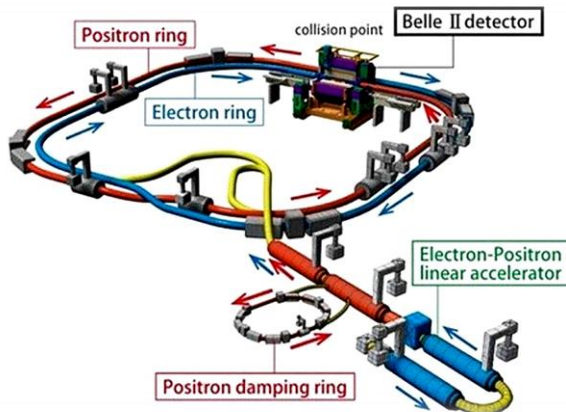

But this isn't the only example of how the shape of the accelerator works to more efficiently generate square

THE TWO SYNCHROTRONS OF CHEOPS

waves as used in superballistic ultrasonic applications. The only openly-known working Tesla Tower in the world is located in Istra, Russia where it has sat churning out free energy since the late 1970s:



CONTINUOUS NEGATIVE FEEDBACK LOOP

In 1986, a French 3-D modeling company used microgravimetric sonar to pierce through the nearly 7 million ton veil that was Cheops to learn where any inside chambers might be located, touched on briefly a moment ago. The results showed there was in fact a continuous running chamber from near the base of the pyramid, ending

Cheops SPOKE Pt 2

close to the capstone. This is the colored image below. Beneath that is a sketch produced by a long-time researcher of the pyramid (*Jean-Pierre Houdin*), theorizing there must be such a chamber that would have to exist inside the structure, enabling a method of construction that made more sense than using cubic miles of sand to build up ramps to bring up such massive stones for its original construction. He wasn't aware of sonic levitation, so he was driven to find such a tunnel to explain how it could have been built:

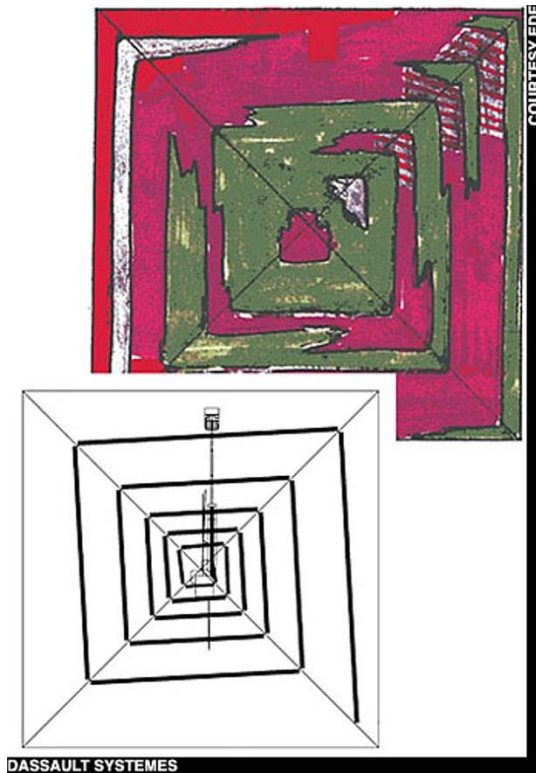

THE TWO SYNCHROTRONS OF CHEOPS

More than a dozen years after the image was captured by the research team, Houdin only then learned that such a test had been performed while giving a lecture on his theory in 2000 and one of the original researchers who happened to be in attendance informed him at that conference they had indeed had one of their computer-generated graphics yield an image they couldn't interpret, therefore ignored at the time that would confirm the presence of such a chamber.

Within an *oscillator* that produces the heartbeat of a pulsation wave, there is always a *negative feedback loop* that is connected from the output to the input that cancels out part of the original wave, creating a *resonating* tone in the resulting square wave pulsation that doesn't tear itself apart:

Wikipedia: Negative feedback;

“Negative feedback (or balancing feedback) occurs when some function of the output of a system, process, or mechanism is fed back in a manner that tends to reduce the fluctuations in the output, whether caused by changes in the input or by other disturbances.”

Cheops SPOKE Pt 2

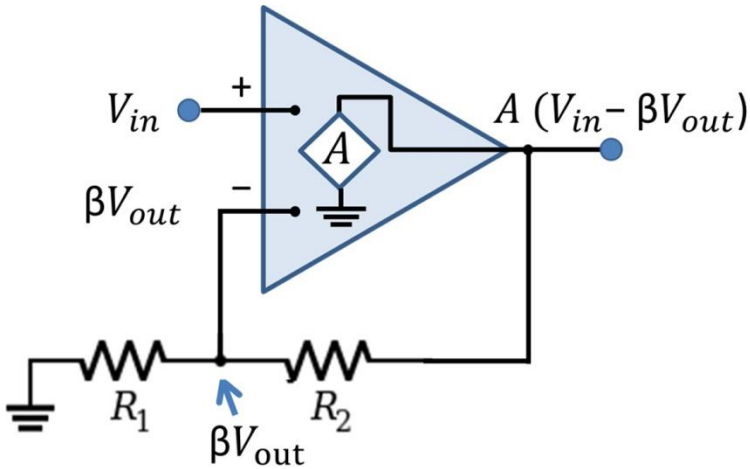

Literally seen here with a pyramid to represent the amplifier as shown from Wikipedia, in order to harmonize the pulsations into a stable synchronization, there must be a feedback loop. This balanced wave then pushes through the air with stronger velocity because the frequency in front of it compresses like a spring on the next pulse which forces the wave to generate a concussion. This continuous chamber would have been a feedback loop made of *negatively charged air* rather than electrical wires:

THE TWO SYNCHROTRONS OF CHEOPS

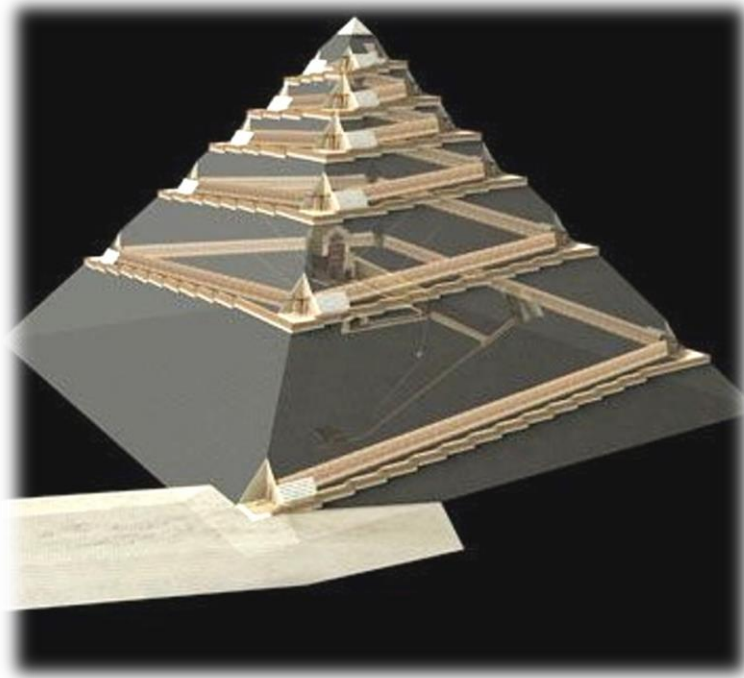

The feedback loop had nothing to do with providing a ramp on which to move stone blocks.

PHOTOCATHODE SUNLIGHT SHAFTS

As mentioned previously, pyroelectric, photoelectric, piezoelectric crystal, or crystal that is inducive to two-way piezoelectric current and the strongest crystal batteries for energy use, such as the crystals that would have been inside the granite columns at the bottom of the hydroduct

Cheops SPOKE Pt 2

chamber, must be recharged by sunlight in order to maintain its high energy.

This would hold true for the diorite sphere we are still getting to in the Queen's chamber air shaft as well, since they would rely on their own energy in order to function as a superconductor. Realize that superconductors using Dark Matter electrons need to be brought down to a fraction of a degree over absolute zero, but it has repeatedly been shown that crystals such as quartz and Bismuth already function as superconductors at room temperature. But not for Dark Matter electrons, as they produce a quantum magnetic signature which cancels out electromagnetic signals.

Like Higgs Bosons that morph from being "a hundred or a thousand particles" into one, electrons must be brought down to freezing in order to slip back into Cooper Pairs in order to enter a superconductor. This means they must lose their thermal signature in order to invert once again to neutrino status. Superconductors do not process electrons; they only process neutral ions, or more exactly, neutrinos. The energy inside a superconductor will be increased by sun waves, just like a regular crystal, but those waves will never invert ions into Dark Matter just by warming up under those waves.

Crystals are formed by, and recharged by, neutrinos carried in solar waves as we have covered repeatedly. Also repeatedly we have covered the fact that neutrinos are

THE TWO SYNCHROTRONS OF CHEOPS

subatomic particles, not 3D particles, and therefore can pass through dense material such as rock and stone. But the energy held inside of crystals is also amplified or fed by solar rays that carry neutrinos as shown in photosynthesis which doesn't involve the creation of a new ion. So they in fact have dual recharging systems. One for the basic charge (neutrinos) and one for their "above ground" charge (photons). The above-ground charge gathered from the sun is oxygen. As you know by now, water droplet that have never been exposed to the sun carries little to no oxygen, but those that have, do. That oxygen is energy and recharges crystals just like sun waves.

Inside the Cheops pyramid is nearly 7 million tons of solid granite with another almost 7 million tons of solid limestone below that is actually the lower half of the entire structure, even though we can't see it:

Cheops SPOKE Pt 2

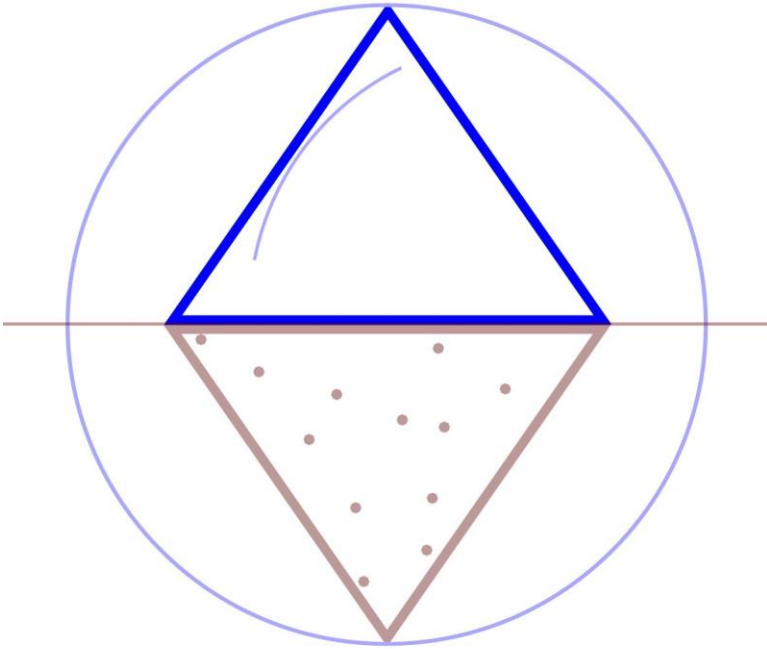

The electrostatic magnetic field around the pyramid portion extends down into the ground an equal distance to its height above. Neutrinos keep that entire structure at basic charge, but photons striking directly onto the crystals are what gives it the breath of life as it were, filling them with the super-powerful charge of oxygen.

As you can see below, there is a shaft that has been cut out through the solid limestone beneath the Temple, leading directly down to the 4 columns in the hydroduct chamber in a straight path. Likewise, there are shafts that were specifically engineered into the construction of the pyramid leading down to the sarcophagus found in the King's room,

THE TWO SYNCHROTRONS OF CHEOPS

as well as to the diorite spheres that would have been wedged into each of the two shafts in the Queen's room:

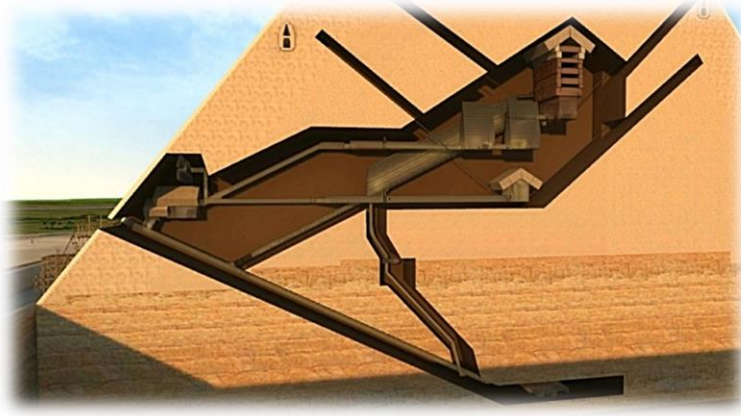

The shafts that lead to the diorite box in the King's chamber and to the hydroelectric chamber are all open to the direct path of the sunlight. This direct path is all about recharging the stones in these areas from direct photosynthesis. You will notice that the two shafts pointing to the bottom portion of the Queen's chamber are sealed by many feet of stone between the room and the outside surface. This is because the Queen's chamber was designed to be a sealed enclosure for reasons that will be clearly explained soon. But that doesn't mean it would not have been recharged by photosynthesis through gamma waves.

As referenced many times already, neutrinos that can freely pass through any material literally create ions. It has also been established recently by physicist *Konstantin Meyl* that

Cheops SPOKE Pt 2

what we have been calling photosynthesis that causes ocean water to evaporate during the “splitting” process is actually *neutrinolysis* that imparts oxygen into the hydrogen at the time most of the liquid is broken away from Aniline crystals and lifted into the atmosphere. Of course you know by now through innumerable references that oxygen is the code word for electricity. So while direct sun waves may not penetrate the granite blocks between the outside surface of the pyramid to where the Queen’s chamber shafts open up, the neutrinos carried by gamma waves certainly do. This keeps all photoreactive cells such as the quartz crystal literally saturated within the granite blocks and diorite at a constant, medium piezoelectric charge.

The reason why the shafts leading to the Queen’s chamber do not lead all the way out to the outside of the Temple, as the other shafts, is because the neutrinolysis required to keep the crystals in the superconductor diorite spheres (we are still getting to) and the room itself needed less direct photon contact in order to keep them recharged enough to power that cathode. This is because the Queen’s chamber powers the “lamp” we are coming to yet that will collect its energy surge through a very unique process not used in the other room.

Both of these main rooms within Cheops are actually oscillation chambers. Each one has been harmonically tuned to different wavelengths to harmonize with the signals created below in the hydroduct room, allowing for two unique phases within this Control Temple. Due to this, these rooms work in totally different ways, yet both are still

THE TWO SYNCHROTRONS OF CHEOPS

very much photocathode resonation devices. The stones blocking part of the light shafts going to the Queen's chamber are there to seal that chamber off from the open air, whereas the King's chamber relies on the open air as well as the higher voltage needed from direct sun waves that recharge those stone walls and photocathode box to peak charge.

As already covered, neutrinos set the piezoelectric charge in stones at a constant level, while photons bring them up to a higher magnitude. As you will see, water will play an important role in keeping the charge very high for some of the stones and geopolymer rocks within the device, and neutrinolysis in both the inner stones as well as the electrolyte solution is definitely a key factor. Let's take a closer look at this liquid energy now.

CHAPTER 18

“SUBTERRANEAN HURRICANE”



Little known about Cheops was the fact that this pyramid, unlike the smaller ones within his complex, had another strange feature; it was surrounded by a retaining wall. It has been extensively debated this wall once brought in water from the Nile to Cheops for some reason, as there are what arguably appear to be boat docks at his base. There is clear evidence of a granite-lined waterway leading from the

Cheops SPOKE Pt 2

river, as well as evidence of the retaining wall that surrounded the entire structure as shown in a recreation here direct from Wikipedia:

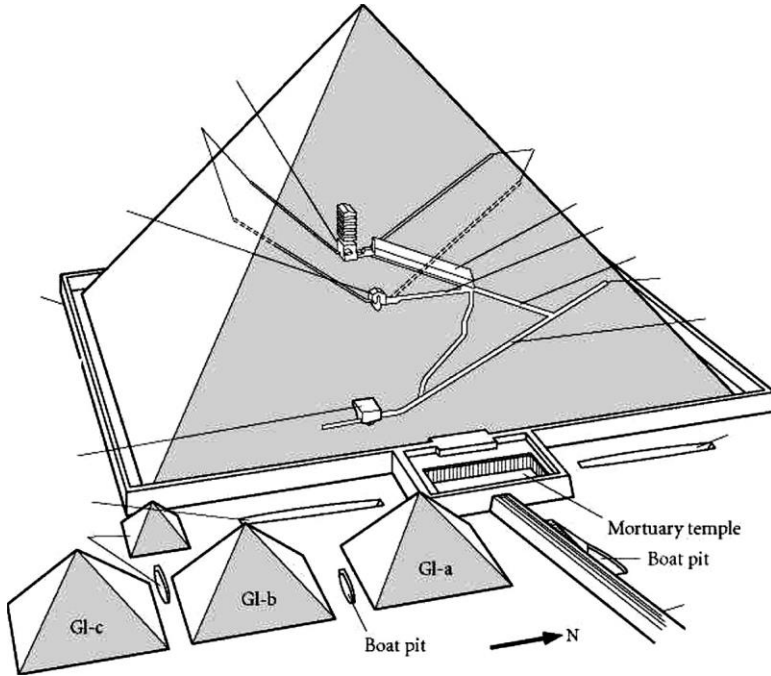

The Control Temple of *Neferirkare* between Giza and Sakkara has been identified as having the same moat as well:

RADIANT ENERGY TRANSPONDERS

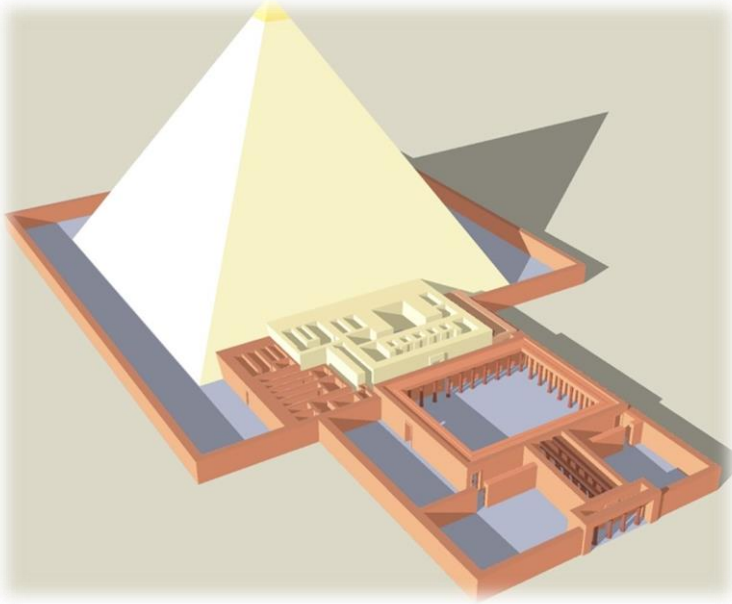

Clearly there is absolutely no logical reason a gigantic burial tomb or a grain silo would ever need an elaborate moat surrounding it, as it would do nothing to slow down tomb raiders, so what was it there for and how did this large pool of water wind up above ground continually refreshed out in the baking sun? Obviously, since both of these moats are known historical facts to have existed, not to mention surrounding many others, there was clearly a good reason to go to all this effort.

In a 500-pound scale-model of the subterranean chambers and shafts below Cheops, marine engineer, *John Cadman* performed an elaborate acoustics and fluid dynamics experiment over 1999 and 2000 to study the theory that the great labyrinth below the pyramid acted as a *hydraulic ram*

Cheops SPOKE Pt 2

pump; a method of pumping water used down through time as shown by the Greeks some 300 years before the change of the calendar. He had based his study on his own knowledge of fluid dynamics as well as the mechanics laid out in the 1962 book *The Pharaoh's Pump*, by *Edward Kunkel*. It was far more than just coincidence that the aqueduct system underneath Cheops was laid out exactly to hydraulic ram pump blueprints shown to be used in even very ancient times; complete with the identical sloping plane, valve placement, breather placement, check valve and even source / waste ducts. It was clearly all right there as illustrated from Cadman's report:

RADIANT ENERGY TRANSPONDERS

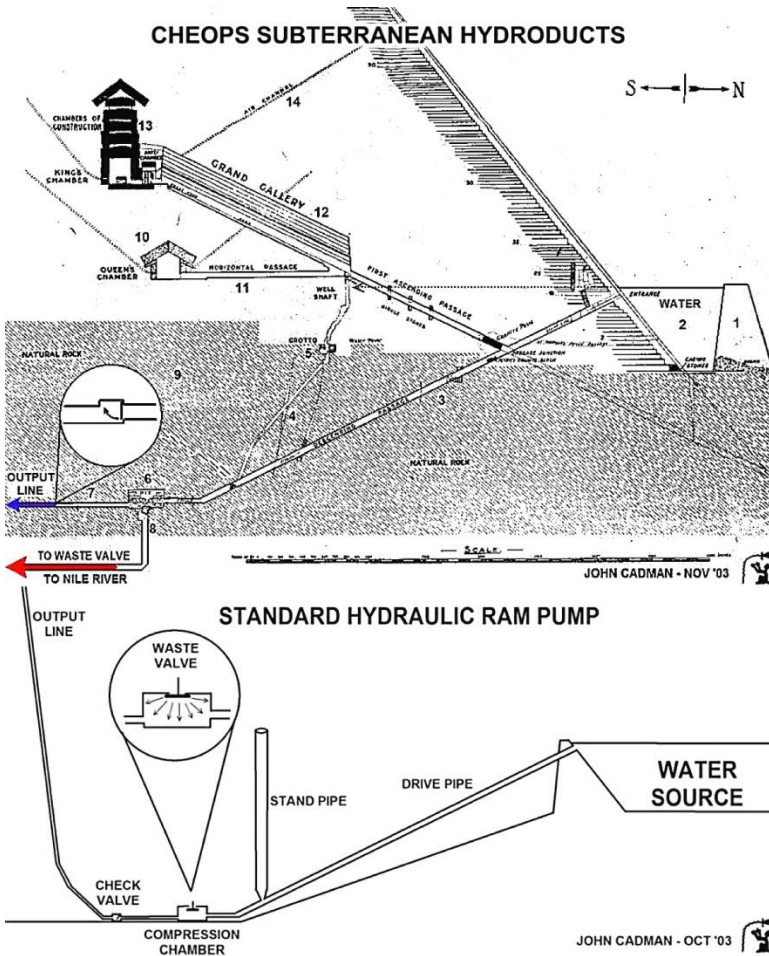

This was no minor experiment; Cadman would go through numerous tests and very large scale models to reach his conclusion, but after nearly a year of failed prototypes, he learned that it really was a ram pump that worked perfectly, just by clearing two shafts already there that have been sealed up in recent times:

Cheops SPOKE Pt 2



Through the course of his research, Cadman learned that in order to work, his model would need to be encased solidly in concrete and placed in a water source. Once he had, the model worked flawlessly. Not only that, but he learned that the system under Cheops employed not only advanced fluid dynamics, but advanced acoustical dynamics as well. The pulse created by the hydraulics acting as a fluid ram generated a decided sonic vibration; a heartbeat-like thump that could be felt through the ground *twenty feet* away and heard nearly a hundred. Due to the powerful pulsation his model generated, Cadman named it the “pulse generator”.

The subterranean chamber below Cheops is hardly an unfinished room; where the “sarcophagus” lies is inside a complex submersed sonic resonance chamber of solid

RADIANT ENERGY TRANSPONDERS

piezoelectric limestone with baffles and directional geometric slopes to direct the sound vibrations and wave distortions precisely up the ascending shaft leading straight up to the first set of magnetrons in the next chambers above, which are offset to the above-structure another 45 degrees.

The generation of the initial sonic waves from this room follows the precise pattern needed to begin the concentric spiral to feed from one resonance chamber to the next and from one level to the next. If any of these geometries had been missing, the aquatic generator room would simply not have worked to produce the pulsation needed to begin the flow of energy, nor would it have directed the standing waves through the shaft at the correct angle (with the right flat planar wall at its end) that would enable its amplification in multiple stages as it continues its spiraling ascent. Additionally, it also would not have worked as a hydraulic ram that besides creating a powerful sonic wave, also uses those waves to move water to a remote well or ultimately to the Nile. However, the model did work, proving Kunkel's theory.

In an excerpt from an article written about John Cadman's research, *Edward Malkowski* reports:

A New Theory for the Great Pyramid: How Science is Changing Our View of the Past;

"The subterranean chamber pit is offset by 45° in relation to the general configuration of the chamber

Cheops SPOKE Pt 2

and is aligned northwest to southeast. According to Cadman, this is so because a plane placed at a 45° angle will maintain the unidirectionality and consistency of the compression wave. In other words, this reflective elbow ensures the consistency of the compression wave. **Any other type of elbow at the pit's bottom would diffract (scatter) the compression wave.** So the pit's alignment is strictly for acoustical dynamics and for creating a standing wave in the waste line and subterranean chamber:

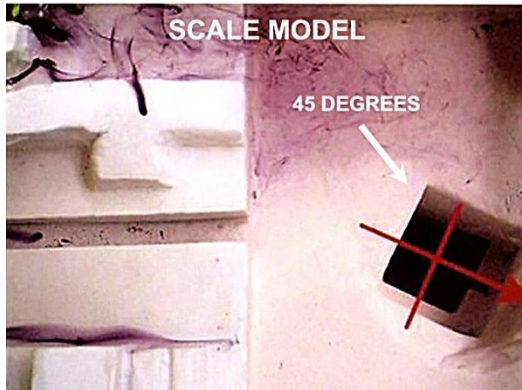
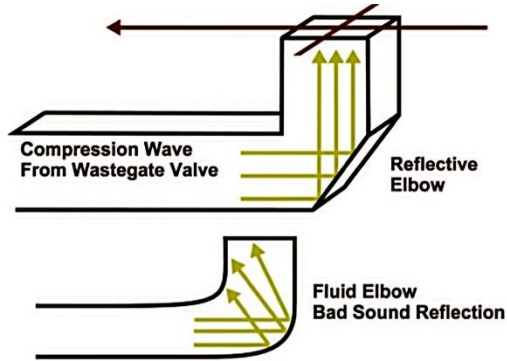

“To create the standing wave in the waste gate line and subterranean chamber, it would be imperative to have the reflective elbow. The pit's offset is

RADIANT ENERGY TRANSPONDERS

exactly aligned with the tunnel (see right; the red arrow is aligned with the exit tunnel). Not only does the reflective elbow completely explain the pit's diagonal offset, but it also confirms that the compression wave is a major design consideration. The designers thoroughly understood complex fluid dynamics as well as complex acoustics (see figure 8, right; the red arrow shows the direction of the tunnel at the bottom of the pit; the ink injection photo shows some of the flows in the step area)."

The reason why the angle of the Westgate valve had been fashioned with a non-fluid elbow, rather than the radius curve that would always be associated with fluid hydrodynamics, is because it was designed to direct the Deuterium heavy water coming up from below the chamber, mix that with the water from the lake source that supplied the water to the "moat" around the base of the pyramid and then direct the acoustic waves generated by the ram up the vertical shaft leading to the burial chambers directly above the hydroduct room. The limestone-encased waterway to the Nile provided a path for wastewater produced by the pump.

Of course, there was more going on here than just moving water and creating a sonic thump; Deuterium salt water was being used to generate hydrogen for the functions that would take place in the superstructure above. We will get to that shortly.

Cheops SPOKE Pt 2

All of the water that would have been in that moat from Lake Moeris around Cheops' base would have been continually mixed with pure Deuterium from the subterranean hydroduct that would have created what science calls "dissolved ions" (pure, raw energy), making it an electrical conductor (the same water that would have been inside Baghdad Batteries). Since the Deuterium/lake water would have now become an electrolyte solution, that would have formed a torus ring around the base of the pyramid that would have been flowing continuously with excited negative electrons, creating an electrostatic magnetic field solidly grounded to the upper structure. With no other form of static electricity from the stones, the magnetrons, the crystals or the monoatomic gold, that torus ring would have placed that entire paramagnetic mountain inside of an *electrostatic magnetic torus field*, from its peak to 490 feet below the ground.

Later, the water ring around the bases of Control Temples would be emulated by kings and queens around their castles, mistakenly thinking that it had been a moat used by their ancient ancestors to protect the Energy Grid Temples from marauders. However, without the thump generated by the hydraulic ram along with a subterranean crystal-powered electrostatic energy plant, it wouldn't have enveloped their castle with eternal, absolutely free energy. Not that they remembered how to use it by that time anyway.

In summing up the dynamics of the dense materials of the shafts and chambers below Cheops, including the

RADIANT ENERGY TRANSPONDERS

engineering of each one's angles and hydraulic acoustic responses, Cadman stated:

“The dynamics are on par with that of computerized storm analysis: somewhere between hurricane dynamics and tornado dynamics.”

BRIEF OVERVIEW; HOW CHEOPS WORKS

In a *very brief* overview that will be thoroughly covered in a moment, this is how this Control Temple functions;

- The concussion produced by the hydraulic ram pump from the bottom of the hydroduct chamber produces a *moving wave*.
- Two separate electrical signals produced by the sarcophagus and stator post columns inside the electrolyte solution Deuterium/lake water is then pushed away from that generator, deflected by the 45 degree duct directly upwards to dual magnetrons in the burial chambers above.
- They are then amplified and sent higher yet into dual synchrotrons in the Temple(s) above. There

Cheops SPOKE Pt 2

they will be amplified again and sent out of the pyramidion, ionizing the air.

Now, here's the science.

STANDING SQUARE WAVES

As you recall now in one graphic illustration first shown of the “Osiris’ chamber”, or the *hydroduct chamber*, illustrated 4 pillars surrounding the “sarcophagus” submerged in the center which would have been made of poured Basalt/Bismuth to turn it into a very powerful, self-energized paramagnetic magnet and then filled with an assortment of powerful quartz crystals inside to supercharge further its energy signature. That was a graphic made after the pillars had been removed, and followed the shape of the stone box in the heavy water Deuterium in the middle of the room. Here is a slightly different illustration:

RADIANT ENERGY TRANSPONDERS

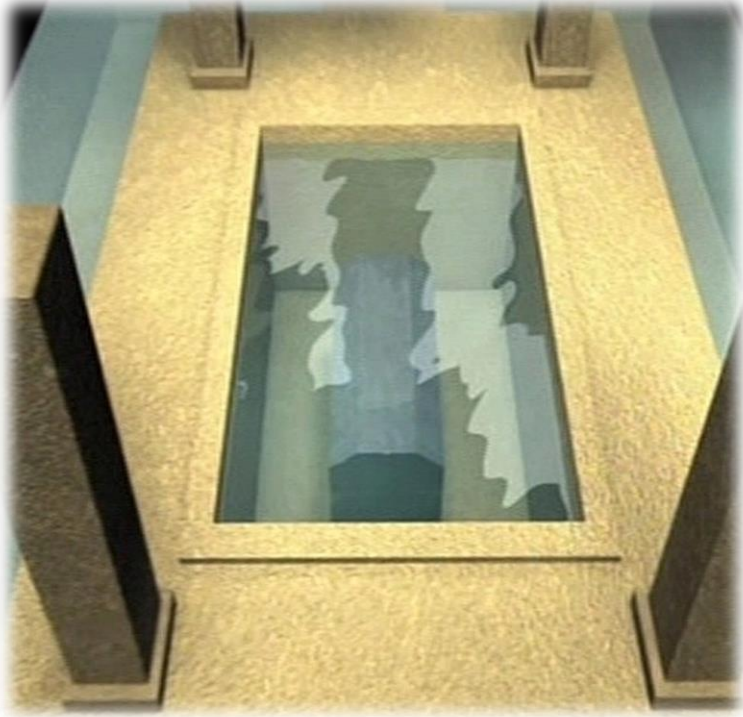

While it is a nice illustration, the positions of the columns wouldn't have been in this pattern, but rather in a perfect square as already mentioned around the sarcophagus in the middle as shown here, which correlates to the actual dimensions of the original schematic of the room and of the pillar placements:

Cheops SPOKE Pt 2

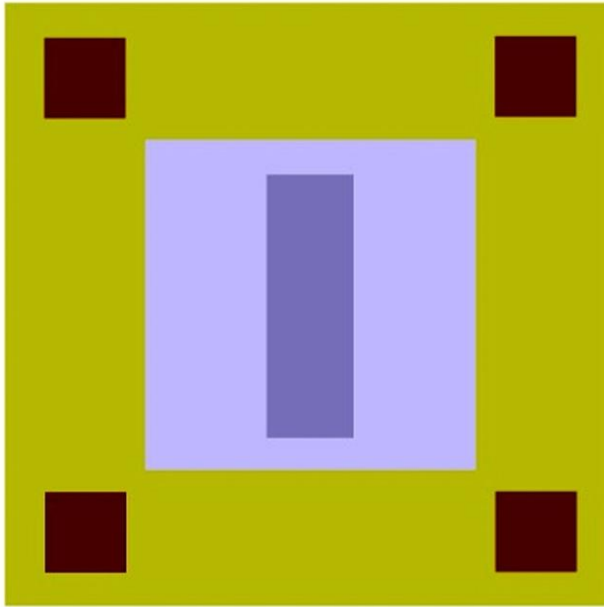

And the reason for this is simple; the pillars are actually the *stator posts* of the generator and would need to be positioned equilaterally from each other so each phase being generated would both harmonize into one unified toroidal field which would surround the sarcophagus and the pillars, as well as the entire room.

Note the pillars are square, not round. If you want to conduct energy (induct permittivity) without loss into the open air, your posts would be concentric. If you want to amplify secondary emissions at the sharp edges of that post that would then beam out of those points as a broadcast

RADIANT ENERGY TRANSPONDERS

*signal, then it would have sharp edges as covered soon in the section **Synchrotron Photocathode Waveguides**.*

MAGNETIC FIELD EXPLAINED

*Ions are made up of two waves. The **anion** waves gather energy from the sun's waves (both from neutrinolysis as well as from photosynthesis), then imparts that energy to **cations**.*

ANIONS = GAS TANKERS

CATIONS = SPONGES, EMPTY GAS TANKS

Normally anions are always casually attracted to cations in order to refuel their gas tanks. Cations hold a positive charge, and anions hold a negative charge.

*When all the anions and the cations within one field are totally full of fuel, then those two repel away from each other – like when you have had enough to eat and **push away** from the table.*

When the ions and cations in any one space become excited in a spiral motion (like a hurricane), it

Cheops SPOKE Pt 2

forces them to brush against each other, uniformly distributing all the anion energy to the empty cations all at once, which then causes half the air to move over here, and the other half to move as far away over there as they can get from each other.

*This is **SET**, or static electrical transfer that causes such a strong repulsion between the two waves. As long as that spiral motion is maintained, there will be an excited magnetic field highly defined within that “torus”.*

POWERING THE MAGNETRONS

The energy from the crystals inside the sarcophagus continues infinitely, as the crystals are continuously recharged by never-ending neutrinos that flood over Urth-space, non-stop. When neutrinos strike the stasis or *empty cation* cells inside the crystal, it feeds the crystal just like water (that carries this energy) feeds all life within this plane. Neutrinos pass through stone just like they do air, so the mass of the structure would present zero hindrance from recharging to their core levels. The air shaft already covered shows how this room was also flooded with photons each day to take advantage of the natural photosynthesis that would occur nearly 365 days per year in the sunny skies of Egypt. In addition to this, the water surrounding the outside base of the pyramid(s) is

RADIANT ENERGY TRANSPONDERS

continuously undergoing neutrinoysis, keeping the water at a peak charge at all times.

The pressure that Bismuth liquid glass places the interior crystals of the sarcophagus under is the trigger for it to release this energy in the form of sonic waves; each one carrying what science would call *energy packets* that then resonate into the electrostatically-charged *electrolyte* water encased in a pure piezoelectric shell (the limestone chamber). This generates a magnetic field composed of two resonating waves that are continuously turning in a clockwise motion, the Dark Matter and Light Matter waves we have been covering since the start. The stator posts at each corner of the room would be formed in two different pairs of pillars that would be matched to the other in size to generate two different sonic frequencies.

These two **paired waves** then form a *torus field* around the sarcophagus forming an apple-shaped energy shell around it, which continually emits forward-moving energy from one end, and an incoming energy (magnetic) from the other, which charges the torus and completes the field. The sarcophagus has an electric, positive side, and a magnetic side, making it function exactly like the torus field created by the wound copper wire in the electric motor's *rotor* which as you recall, turns it into a giant magnet.

Realize that only two *stator posts* would be needed in order to generate an energy field, but in Cheops' case, there are

Cheops SPOKE Pt 2

four, which makes the Great Pyramid a *dual-phase generator*. Or, in very real terms, like a *Tesla Coil*:

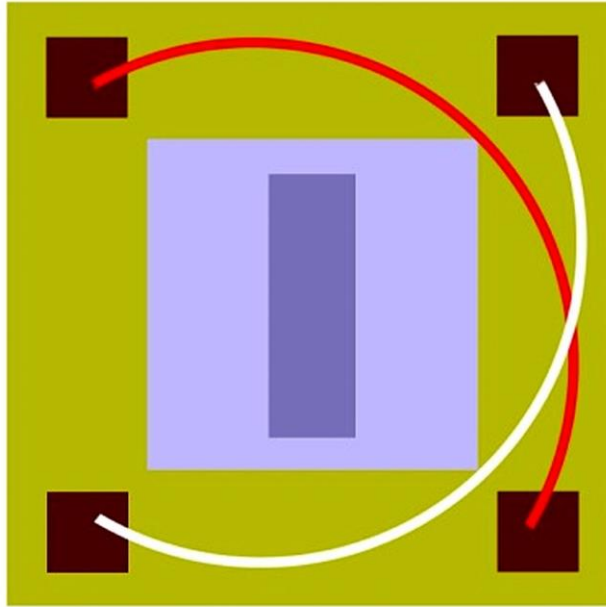

The sarcophagus does not have to “move” in order for these wave fields to continually counter-spiral around its toroidal field. That field moves around the sarcophagus magnet and interacts to the crystals within the columns that are situated at its four corners, explained in a moment. Realize that these energy signals are what power the magnetrons that are positioned directly above the hydroduct room, so in magnetron-speak, two of these stator posts will be one cathode charge, and the other will service the second

RADIANT ENERGY TRANSPONDERS

magnetron. One is tuned for the resonance of the outside four cavity sonic chambers which will generate the sonic pulsation of the larger pyramid above, while the other stator posts will be tuned to the inside four cavity sonic chambers to power the smaller pyramid. By using two sizes of stator pillars, this creates two unique frequencies, so both frequencies can enter into the two magnetrons above at slightly different times to create separate phases.

Inside a *single-hull cavity magnetron*, energy is emitted from a cathode (each set of the dual-paired pillars on each side of the sarcophagus) that begin moving from the first pillar directly toward the other leg called an anode, but when a magnetic field is applied directly between those two points, it pauses the signal briefly, creating a pulsation. This is also known as a *triode amplifier*. The principal of **pulsating amplification** is illustrated through the *left hand rule*:

Wikipedia: Fleming's left hand rule;

*“When current flows through a conducting wire, and an external magnetic field is applied across that flow, the conducting wire experiences a force **perpendicular** both to that field and to the direction of the current flow (i.e they are mutually perpendicular). A left hand can be held, as shown in the illustration, so as to represent three mutually orthogonal axes on the thumb, fore finger and middle finger.*

Cheops SPOKE Pt 2

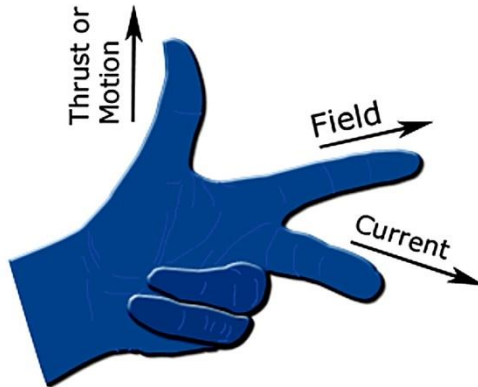

- *The Thumb represents the direction of Motion resulting from the **force** on the conductor*
- *The First finger represents the direction of the **magnetic Field***
- *The Second finger represents the direction of the **Current**.”*

The sonic heart-beat of the hydraulic ram explained previously then generates a pressure wave that doesn't just pump water, it pumps ions. This initiates the *electrostatic kinetic pulse* that will now begin moving from this lowest level of the nearly 1000 foot-high megagenerator.

- The overview titled **OSIRIS ROOM** two images below was the true layout of the hydroduct chamber (1).

RADIANT ENERGY TRANSPONDERS

- The four posts that make up the two pairs of stator coils are shown in illustration (2).
- As you recall, the rotor that spins inside the motor (in this case the *generator*, which are the same general construction) is actually a magnet with both a positive end and a negative end (3).
- In graphic (4), as the toroidal field is placed under pressure by the hydraulic ram sonic waves to flow, the magnetic field from one surface of the sarcophagus magnet reaches the closest stator column, which sends those ions flooding through the dielectric material (that is openly absorbing those ions without reluctance), this enters the side of the column and radiates out the top (away from Urth's magnetic field), which then pushes those ions directly away from the incoming sonic wave to enter into the top of the column tangentially opposed to it:

Cheops SPOKE Pt 2

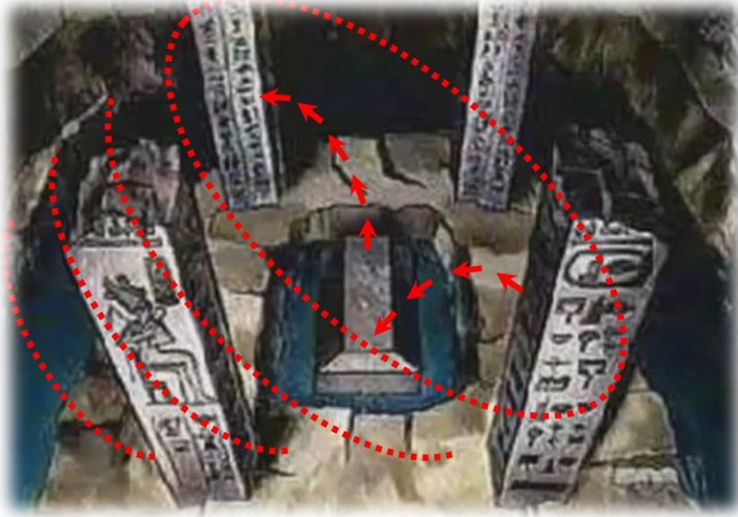

- Remember, the magnetic field from the sarcophagus pulls against that signal, then releases it, pulls again to release again, causing this wave to oscillate in a steady pulsation:

OSIRIS ROOM

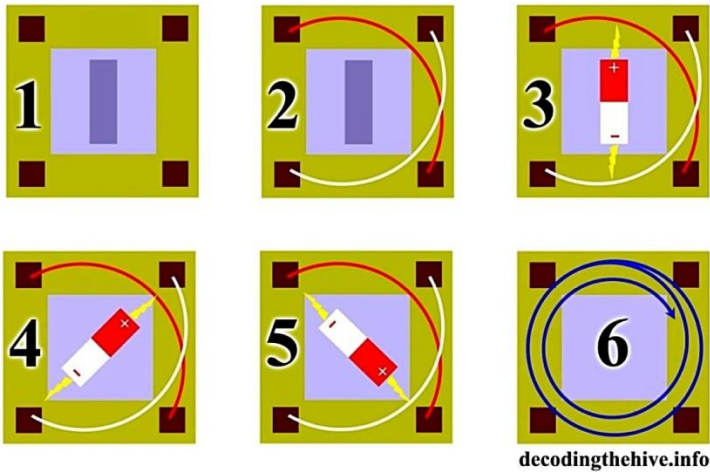

- This sends excess negative ions into that column from the top, and through paramagnetic single-direction flow of energy now pushing downward, forces that electric material **to turn into a totally shielded conductor (4)**. Of course the sarcophagus doesn't actually turn. I am merely illustrating it that way to help visualize how one pair of stator posts are activated, and then due to that now-activated field repelling the free ions from the magnet, the still-flowing energy then jumps to the next open circuit to begin another field.
- Immediately after the first two stator electrodes are electrified, the next pulse of the sonic wave hits the next closest column, which is located just to the right of the first. The ions travel up and out of this column, and then leap to the only other natural ionic

Cheops SPOKE Pt 2

conductor closest in the room that is not already generating its own magnetic field to connect the circuit of the second phase (5).

- (6) The two opposing fields now mesh into one magnetic toroidal field made up of two defined frequencies, each pulsing in harmonic resonance with the other in a stepped phase. Now there are two *nested "hurricanes"* of energy in a single, invisible funnel between the four stator posts. With the very next thump of the gate valve on the hydraulic ram, that nested toroidal field is swept away from the gate, *toward the vertical shaft*.

Realize we are talking about three different things when discussing sonic waves and electricity. While sonic waves carry energy potential, just like electricity, it is in an audible form, rather than light form. Sound *moves* energy. It can move static piezo electricity or it can move *electron electro* electricity, both in the same way while electrons remain inverted as Dark Matter. When water is turned into an electrolyte solution with salt, it becomes a conductor simply because it now has a concentration of excess cations which creates a magnetic field. This separates cations from anions (positive from negative) due to the oversaturation of both waves in overabundance for that one space. This distributes energy throughout all the cations and anions uniformly which forces the two waves into repulsion from each other, rather than attraction.

RADIANT ENERGY TRANSPONDERS

This is called *electrolysis*. The polar opposite ions in the water when placed into an electrified state (now all fully recharged with oxygen) then seek the furthest distance away from each other, the same way as waves are observed when a pebble is dropped into the water. The pebble carries the same type of charge as non-electrolyte water droplets, so the waves (now anions) then move away from that pebble (cations) which generates secondary emissions in the form of free ions now searching for other cations that aren't already full of energy. The wave will not stop until all the excess ions have found a new home, at which point the visible motion comes to rest (but the action or message of that action never ceases to move outside of your visible spectrum):

- **CATIONS = STATIC** (like rocks, stators, things that don't normally move)
- **ANIONS = ELECTRIC** (like rotors or waves that are always in motion)

While sonic energy can be applied to electricity as explained previously to assist in developing a magnetic field to cause electricity to flow, it can also be used to push electricity through chambers in air as well as water because as you recall, air is water. We see water waves with our eyes, but the waves in the air would look just the same. And with each precise **deflection** of that sound, if it generates a resonant harmonic, this produces its own energy field that attracts more ions, like secondary emissions within a torus field. Deflection is not diffraction. One uniformly directs the energy like Cooper Pairs together

Cheops SPOKE Pt 2

in one single beam; the other defuses and scatters that beam on a tangent or in multiple different directions.

- **DEFLECTION = COOPER PAIRS** (laminar, uniform travel as a single unit, wind)
- **DIFFRACTION = FRACTALIZATION** (scattered, broken apart, diffused)

Sonic chambers are the same equation to its force as torus fields are to electrical force. Torus fields always vibrate in harmonic resonance, thus they create more ions through friction, and through the same friction harmonically-resonating sonic chambers generate secondary emissions that amplify its magnitude exponentially as well. **Friction** is how energy is imparted from anions to cations as you recall now.

We just saw the fundamental science behind using sonic waves that act like a switch to begin electricity flow from the hydraulic ram pump concussion. That concussion is energy now moving away from the point of origin that is already full of anions. When that flow is directed to create two phases of electrostatic streams as harmonized into their own different signatures (frequencies) from the two different sized pairs of stator posts, they combine together in one torus with two invisible threads wrapping around the donut or hurricane if you will. They are identical waves to each other at this point, with the same energy potential, but

RADIANT ENERGY TRANSPONDERS

they can now move together as one force, because their phases are slightly out of step with each other.

In other words, just like synchrotron radiation that creates pulsed square waves that “ram” the next pulse from the one following behind, the two phases of harmonizing frequencies within the one “hurricane” resonate and PULSE. So a perfectly harmonized sonic frequency made up of more than one unique “perfect note” will always sound like *woom woom* if it is within your audible spectrum. The *woom* is called resonance or harmonization. The hydraulic ram pump is merely using sonic energy harmonized with the water to force it uphill, defying gravity because it places that water into a Meissner Field.

Normally in a hydraulic ram pump application, all the energy that was used to push that water uphill then simply emits into the air and returns to cation ions who are looking for more fuel for their gas tanks. But if you capture that energy instead inside a sonic chamber, you can now go on to use that energy in another application because it never depletes and it never dies. Electricity is the only thing known in all of creation that never ends. It has no “half-life”. In the hydroduct room that energy was used to infuse the water from the lake in the solar ring around the moat that fed down the declining shaft with Deuterium to produce a continuous electrolyte solution. It also kept that entire room absolutely full of water without air pockets, making a single uniform body that could harmonize in the exact pulsation needed to resonate with the two independent photocathodes (giant boxes) in the two nested

Cheops SPOKE Pt 2

magnetrons immediately up the shaft above where it would go through massive acceleration before moving on up higher into the two synchrotrons in the upper pyramids. The excess pressure created by the ram pump was then channeled through one of the existing hydroducts in the chamber and out to a secondary well or body of water, such as the Nile.

If the two phases were to begin oscillating at the exact same moment, both waves would cancel each other out. But the sonic wave from the hydraulic ram pump would always strike the closest stator post first, and then a moment later, strike the one closest to it which would be the second phase stator post. This minute lag of time is what “marries” the two that can now be carried in one sonic wave. Both unique frequency waves can move together, or they can be separated to form independent beams that can be routed through separate processes at any time, just as any primary radio wave can be separated from its carrier wave that is traveling together from one transmitting station to different receivers. The dual nested magnetrons above were fitted with photocathode boxes of different sizes that were tuned to two different frequency waves for this very reason, to act like independent *resonant induction couplers*.

RESONANT INDUCTIVE COUPLERS

The secret to how the nested square waves will get from one strategic point within the 900+ ft-tall device to the next

RADIANT ENERGY TRANSPONDERS

is through something I have already alluded to called *resonant inductive couplers*, or RICs. These act like black holes calling out to electrostatic signals that are the essence of a cation ion, only in a very large, powerful form compared to an actual subatomic ion. Solid state electronics would refer to this coupler as a “hole” (short for black hole) where energy is sucked into, also known as a *photocathode*. I have already explained how the monolithic black box in the burial chambers above the hydroduct room is constructed using poured Bismuth/Black Basalt, turning it into a black hole in energy-speak.

Also mentioned is the fact that there is another such device in the King’s chamber that was reported to have been found with monoatomic gold inside, though all the various quartz crystals had now been pilfered. Like Black Basalt, the very red rock in the polymer resin of this RIC is made of Basalt Dolomite, which is just another ash fiber species of ancient silica tree, making it simply a specific frequency of black hole/“graphite” composition. Like the burial chamber boxes that were far too large to ever be confused as a “sarcophagus” to any logical observer, it too was massive in size, deep enough to have fit multiple mummies between its floor and lid, and its interior joints were perfectly square, all the way to the finest point of its corners, something that would be physically impossible to have achieved had these not been poured-resin, Bismuth liquid-glass orgonite devices:

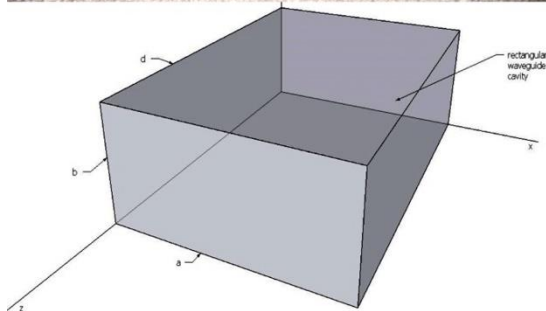

RESONANT INDUCTIVE COUPLER

Resonant inductive couplers rely on those perfectly clean interior joints to deflect ions in order to create secondary emissions while at the same time the perfect cavity size to resonate the right frequency for the incoming wave it is looking for. It is deliberately not square in its design, because it relies on the deflection of ions which would take the same exact path with each strike otherwise, over-taxing the same small sections of its wall surfaces. Being rectangular assures that each strike and each deflection varies its pattern, utilizing all the surfaces equally inside. Again, our RICs would have been filled with crystals as well as monoatomic gold as will be further covered in a bit, but the sonic waves would still have bounced around the

RADIANT ENERGY TRANSPONDERS

inside of this device like the tennis ball in the video game Pong before saturating the coupler with far too many negative ions that would automatically emanate out of its walls and lid, and into the room where those energies were supposed to wind up.

Just like the RF chip in your credit card, these self-resonating chambers need no outside source of energy to continue to function. They are constantly recharged by neutrinos through any amount of “matter” surrounding them. This gives them their baseline charge as already covered. The sunlight pouring in through the airshafts complete that charge each day, causing that room and box to hold maximum capacity. Where your credit card’s chip relies on multiple coiled wires around the circumference to produce a self-powering electromagnetic field to constantly vibrate that signature wave signal it is tuned to broadcast and receive, the photocathode boxes are powered by the ever-vibrating geopolymer liquid glass resin granite box the crystals were placed in:

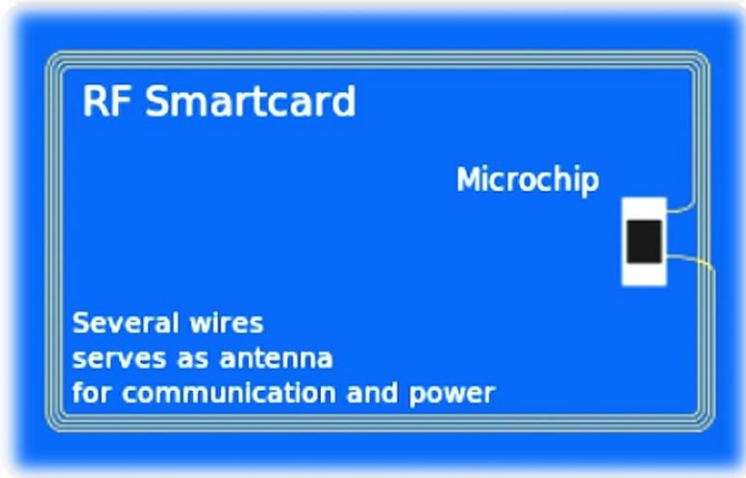

THE TWO MAGNETRONS OF CHEOPS

Take look at the layout of the eight “burial” chambers in Osiris’s Shaft while overlaid to the above ground structures. Had these chambers been situated in an exact square, rather than a rectangular arrangement, the eight points of the two pyramids above wouldn’t correspond when scaled up from the chambers below, which they do when the subterranean room is amplified outward identical to a sonic wave traveling 98 feet would expand. This means, under the Great Pyramid(s) are two separately engineered magnetrons that would power two separately engineered Temples. It also means that one of the two monolithic boxes (D shown again below) corresponds to the inside pyramid, and the other one (G) corresponds perfectly to the outside pyramid.

RADIANT ENERGY TRANSPONDERS

Since each magnetron generates its own unique frequency, we see that each group of four chambers rest exactly below their corresponding corners of the two structures to unify those Temples harmonically to their respective magnetron chamber points:

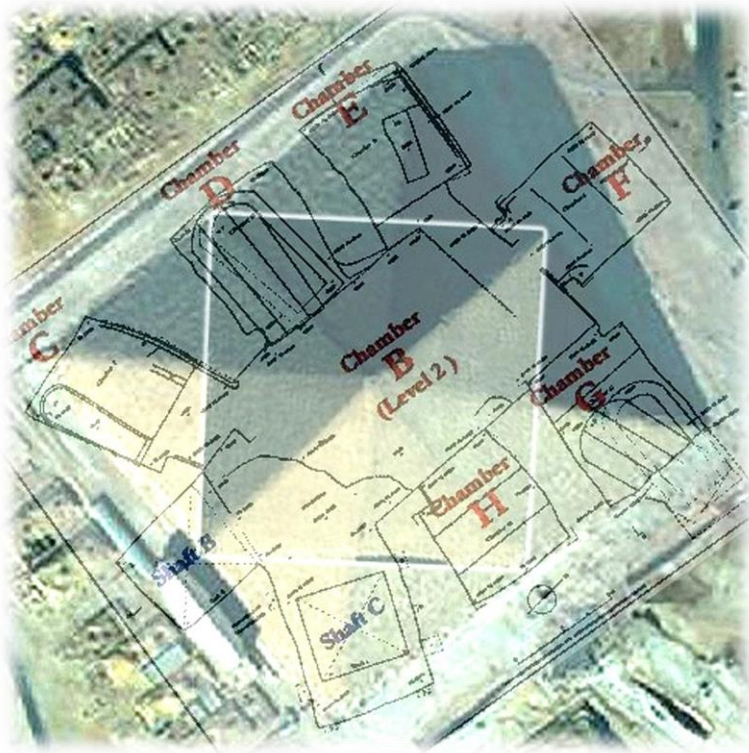

The 7 chambers on level B shown overlaid above (recall that **Shaft B** is also another chamber), plus the hydroduct chamber below where the initial energy is generated at **Shaft C**, together form a full 8-point, geometrically-nested, pair of ultrasonic magnetrons. The reason this is such a

Cheops SPOKE Pt 2

complex construction is because Cheops is a dual-phase system, whereas the other Temples in the network are single phase secondary-emission *transponders*, not actual generators. Before the entire complex will begin working, one of them has to begin the electrical cycle. Below is a 3D look at the subterranean hydroduct room as it is positioned below the magnetrons;

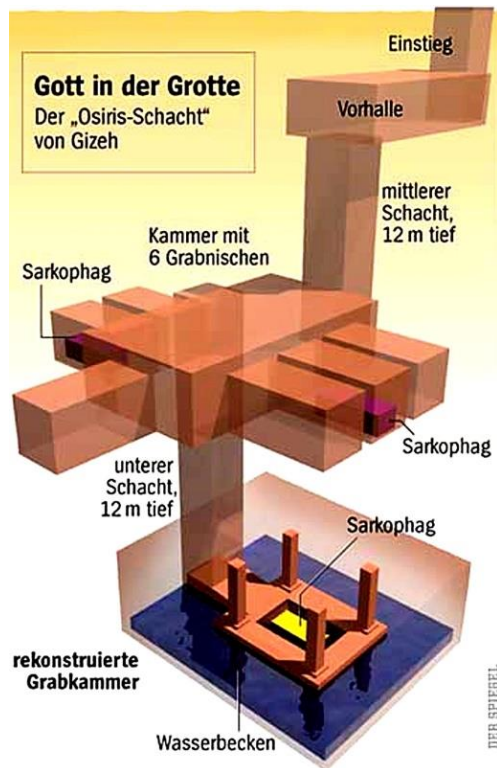

As you can see in the image one graphic above, the wave beams from the inside magnetron (B, D, F and H chambers) would strike the next planar surface within its own

RADIANT ENERGY TRANSPONDERS

resonance chambers without interrupting any of the sonic chambers of the outside magnetron as it generated below in perfect synchronization to the structures above. Like the diorite superconductor perfect sphere (we are still getting to) found *inside the airshaft itself* of the queen's chamber, for this to be mere coincidence would be like finding a four leaf clover in a concrete parking lot.

Below I produced some illustrations to help simplify the math through visualization how it would be possible that square-edged stone rooms are actually cavity magnetron chambers. The actual placement of the upper King and Queen's chambers in relation to the lower burial chambers is precisely mapped out in the scale drawing of a top-view of the two nested pyramids as shown below. The lowest chamber, the subterranean hydroduct room colored in blue, is offset from the dead center of the upper pyramids as you can see. Above, inside the pyramids themselves is the lowest of the two *cathode* rooms which we are focusing on first is the Queen's chamber shown in green and the King's chamber higher up which as you can see, is slightly further away from center even yet:

CHEOPS

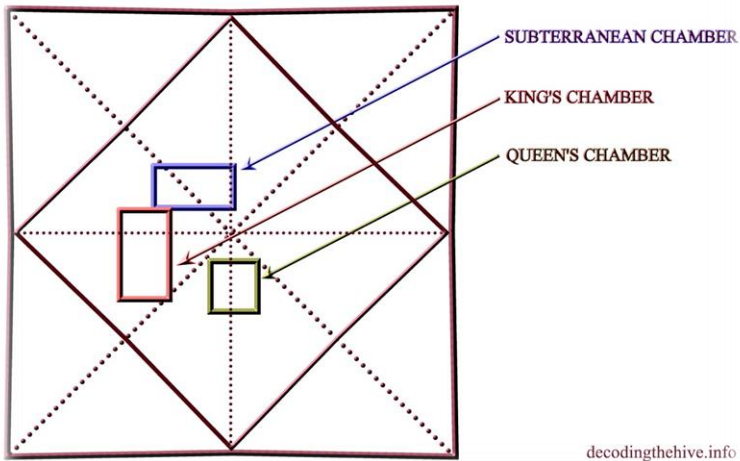

The King's chamber is situated in relation to the outside pyramid exactly as the Queen's chamber is situated in relation to the inside, smaller pyramid. The Queen's chamber is to the right of the magnetrons below, while the King's chamber is further from center off to the left. These placements would trigger an ultrasonic beam from the Queen's chamber precisely centered to the closest planar surface of the smaller pyramid to begin its ascent (upper left), while at $\frac{1}{4}$ turn after that and further away where the naturally expanding larger second beam reaches the King's chamber a bit higher then places it also centered to the closest planar surface of the larger pyramid (far left).

Once the two nested energy signals reach these magnetrons, they are both amplified in separate nested

RADIANT ENERGY TRANSPONDERS

devices, then will travel upward toward the first above-ground resonance chamber of the Queen's room where they will be supercharged together for the next stage. While the first of the two synchrotrons (in the upper structure) will amplify both signals, they will still remain individual oscillation signatures, harmonically tuned to their own respective upper structures:

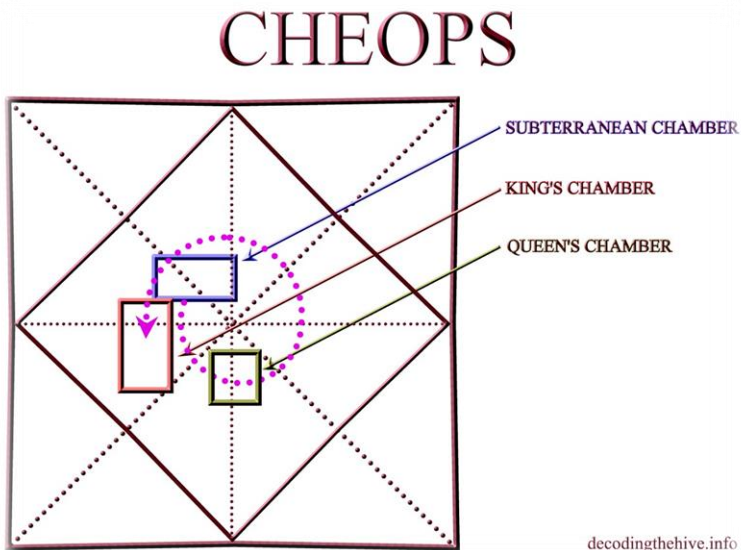

Of course the magnetrons don't spin, but the two phases of energies emitting upward, do. Realize that Light Matter energy travels outward in a clockwise direction away from the source. All the mechanics are in place for the two separate beams to travel in this exact pattern that are aimed to deflect off of the ascending yet tapering square cone(s) above to not only direct the energy, but also to double that

Cheops SPOKE Pt 2

energy each time it strikes another planar surface. There are a lot of surfaces we are talking about here before these will become finished products.

Once the initial energy signals are produced in the hydroduct chamber, then our two separate magnetrons linked to two nested multilevel synchrotrons will finish their amplification of power. As already discussed, a magnetron, cyclotron, synchrotron and photomultipliers all use the same basic formulae of directing energy at planar surfaces to exponentially generate secondary emissions. Magnetrons use hollow chambers to generate ultra-high energy waves and synchrotrons use 90 degree deflection planes. Still, the generation of exponential energy still comes from the exact same method of static electrical transfer which actually produces the energy instantly that is emitted into that resulting wave.

ENGAGING THE MAGNETRONS

Both nested square waves generated by the subterranean electrostatic generator are sent across the body of electrolyte solution in the hydroduct room and away from the hydraulic ram pump. The concussion waves strike the 45 degree, flat planar deflection plate at the bottom of the vertical pump shaft and travel out of the water and into the cluster of 7 individual resonance chambers above. Collectively these rooms are referred to as an *anode* that holds the cation ion potential and the waves entering carry

RADIANT ENERGY TRANSPONDERS

the negative-charge anions. Remember now that two of the paired stator posts from the electrostatic generator below were of a different size than the other two opposing columns, producing one higher and one lower frequency field.

The two nested magnetrons within the “burial chambers” room above are fitted with 4 sonic resonance chambers apiece, and each set has one massive black box inside just one of their respective chambers, with various small inductive couplers sprinkled throughout. The lower-pitched signal known as the *input* of the two nested waves is separated out and drawn into the larger black box in Chamber G that is now acting as a *photocathode* for the first magnetron that has been harmonically synchronized to that frequency.

This first electrostatic resonant coupler in the magnetrons filters out the lower of the two signals through *frequency division multiplexing* which now begins the first amplification phase. Notice now that the pattern this first wave emitting from Shaft C and into the largest of the two boxes travels in a wide pattern from chambers G to E to C, completing its first rotation which will ultimately be much larger than the second wave’s physical path after the two signals separate again in the first of the two synchrotrons. This is because this is literally a longer, lower-tone wavelength than the frequency of the second wave and will be mating to the larger pyramid above:

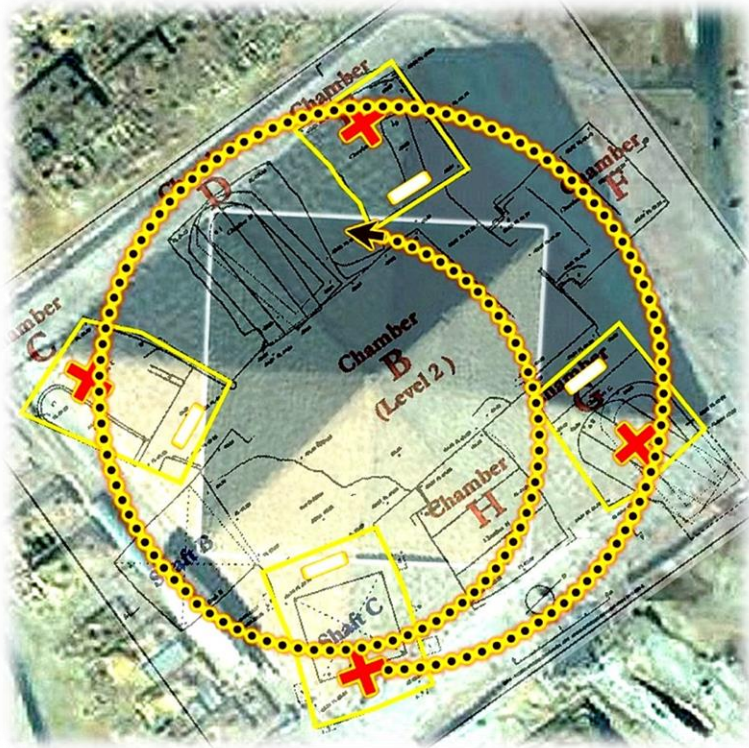

A fraction of a second later, the smaller monolithic coupler calls to the higher signal of the nested current known as the *carrier wave* and will fire the second magnetron that will then travel from Chamber D to Shaft B and Chambers H to F, completing the second acceleration. Remember, Shaft C is actually the *hydroduct room* which is the first sonic resonance chamber of that 4-chamber magnetron, and Shaft B has already been identified as a separate “mastaba” which is simply another resonance chamber of the second magnetron.

RADIANT ENERGY TRANSPONDERS

Both monolithic sonic couplers are fitted with tons of very powerful crystals nestled in monoatomic gold. The signals are amplified inside each box, supercharged by the piezoelectric crystals which then elevates the temperature inside the box to the exact degree needed to cause the monoatomic gold packed around them to generate a **Meissner Field** which suspends the four sonic resonance chambers within the exact circumference of that oscillation field, turning them into a superconductor. Each chamber still supercharges the signal exactly the same way it would without the Meissner Field, but now does so instantly, since it is now in superballistic, **Cooper Pair** trajectory, or **omnipresent**. It entered that superconductor as a square wave, so the oscillation separation is maintained precisely in a harmonic, now **ultrasonic** pulsating concussion wave.

Phase two will now follow immediately behind; striking the **cation end** of the **photocathode** of **Chamber D** a moment after the first carrier wave had struck the **cation end** of the **photocathode** at **Chamber G**. This shorter (higher frequency) carrier wave will now be amplified by these four chambers in its respective amplitude an octave above the first, in resonance with the frequency of the smaller, inside pyramid's signature. Keep in mind the images of these first magnified oscillation waves are all still about 80 feet below the surface, even though I am showing you here how the chambers correspond to the corner points of the two pyramids above. The waves will become this amplitude (size) by the time they spiral up to the bottom of the structure:

Cheops SPOKE Pt 2

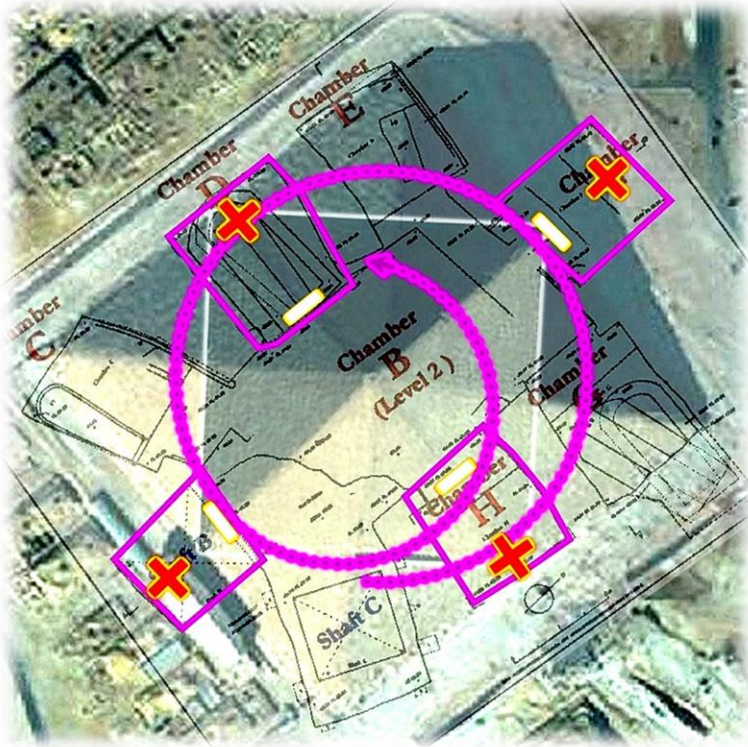

CHAPTER 19

THE TWO SYNCHROTRONS OF CHEOPS

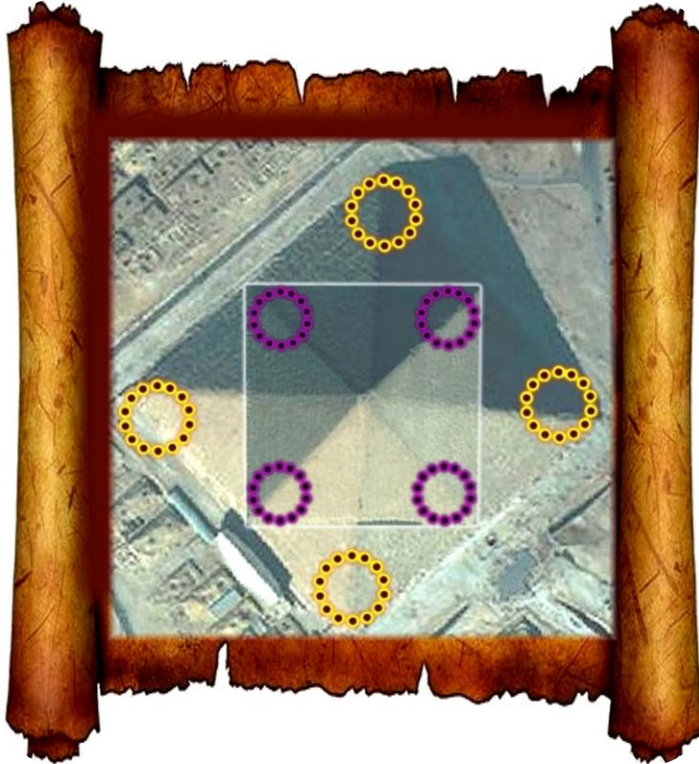

Now the second phase of amplification takes place, where the upper stone structures receive already very powerful

energies from below, and transform them into a precisely-tuned, dual-phased square wave of pure static energy ions. Because the entire structure, from below ground as well as above was specifically designed to harness and amplify electrostatic energy, what is emitted will be a self-insulated ionic flow that was designed to blanket the skies for possibly hundreds of miles in all directions with safe, static electricity. The same electricity that is already in the air from sea level to mountain tops, only now *fully recharged* if you will. This will not just give easy access to free energy to everyone within this radius, but the trees and crops will flourish unlike anywhere else in the world, because the air will now be *supercharged* with pure oxygen through *ionization*. Let's look at how all this happens.

OPTIC CONDENSER

What isn't apparent about the pyramids is the fact that the stones are not assembled in uniform courses such as a brick building today, but each course is unique to that level. A few courses close to the capstone for instance have blocks that are fairly uniform in height, but for the lion's share of those more than 2 million stones, not so much. Each course of stones graduates on a mathematical, musical-scale precision to gradually elevate at what appears to be an intensifying energy flow within a certain structured pulsation. In other words, each stone may appear linear (perfectly rectangular), but with few exceptions, they graduate (called ramping) across one face, while decreasing (this is called sloping) on the opposing face, so the net

RADIANT ENERGY TRANSPONDERS

result is an unthinkable complex rhythm to the stones that would have nearly doubled the length of time to build the structure compared to simply placing almost 7 million tons of the same dimensional blocks one on top of each other to the finished peak:

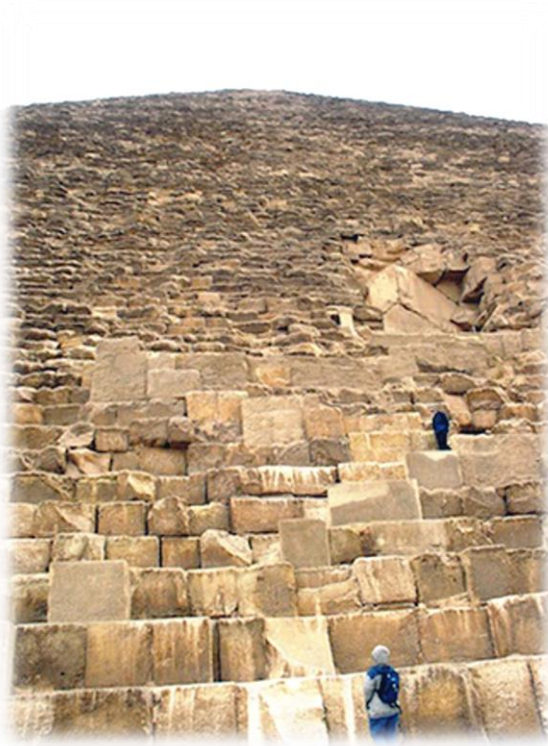

I have been avoiding referencing the incalculable reports from investigating scientists that the Great Pyramid is simply a breathtaking example of the most advanced mathematics relating to the Golden Ratio, and to the precision of block placement, since if there is one thing

Cheops SPOKE Pt 2

everyone on Urth already knows about the pyramids, is that in such a vast and massive construction, even using modern, simple-to-use materials instead of blocks weighing up to 80 or more tons, is a physical impossibility, much less adhering so flawlessly to prime numbers and the Golden Ratio.

We are talking about a man-made mountain that in all respects, and after countless thousands of years of settling in desert sand, still shows optical laser *surgical* precision from top to bottom. However, I must mention that this precision that would have extended the build yet again to twice or many times greater than that the time it would have taken to construct, over and above the fact that nearly no two blocks are exactly the same in dimensions, thickness, depth or weight over the course of millions. There is nothing about this pyramid that was simple, straightforward or logical. At least not if you were building a burial tomb.

There have been at least thousands of assay studies, scientific reports and theses written on Cheops. Hundreds on just the course stones alone. No aspect has been left unturned by this time. However meshing all those findings together inside a comprehensive analysis has still yet to be achieved after millennia of ponderance. Many scientists have taken up this cause in recent years, because evidence has been mounting that what they were really looking at was a massive energy resonator. Incorporating the various data of the materials, construction methodologies, dimensions and silica species involved, algorithmic

RADIANT ENERGY TRANSPONDERS

resulting data shows that not only would ions flow through the dielectric material, but they would follow an exact pattern of exponential acceleration through a highly-tuned resonance pattern, forever pushing upward toward the missing pyramidion.

In one incredibly in-depth report to show that the million different-sized stone blocks were in fact very specifically placed together from the outset by design, and not by haphazard lack of attention (and having nothing to do with the pyramid's actual intended use), here is the pattern of block magnitude on a graph compared to their actual placement in the structure from the base to the peak as viewed horizontally showing the naturally occurring rhythm:

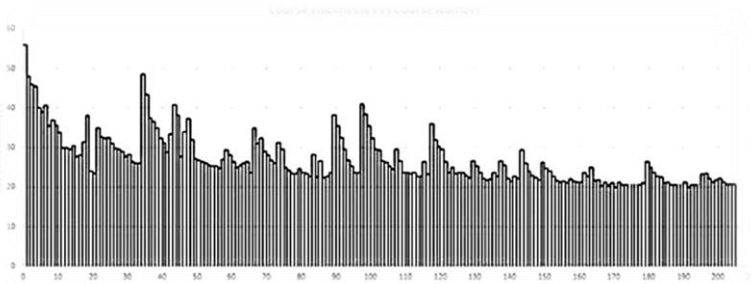

This shows that even the placement of the stones themselves worked in a triangle wave (that works in conjunction with square-waves) fashion to exponentially increase the power as it reached closer and closer to the apex.

Cheops SPOKE Pt 2

In another independent and in-depth analysis, completely unrelated to the previous, the findings showed a very similar pattern that developed. Again, the same sawtooth triangle wave:

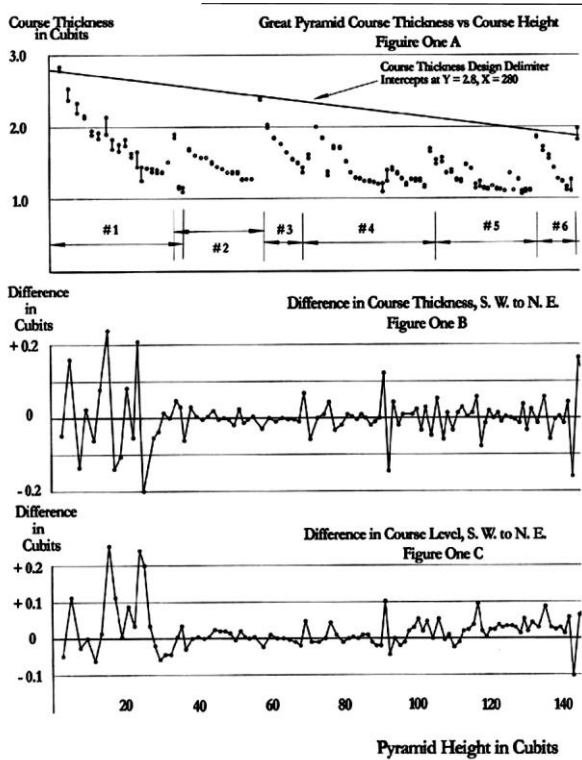

In this case, the scientist just so happened to be an electrical engineer as well, and couldn't help but note that an electrical flow passing through this structure built so specifically to ebb and flow in its construction readily appeared more as *electronic decay* triggered by sequential

RADIANT ENERGY TRANSPONDERS

noise bursts as seen in oscilloscopes in an electrical circuit. This is because the entire project was designed to generate timed magnetic pulses within each of the two structures that would perfectly harmonize at the pyramidion.

It only takes a glance at the data above to see that one analysis that had blended the thickness and mass of each course of stone together resulted in a very clear pulsation pattern, and the other more intricately traced medium resistance and permittivity which showed that the pulsation at the base (to the left) where the energies first enter the upper structure are huge and erratic, but by the time they reached the first synchrotron (Queen's chamber) and the beginning of the direct-tuning of the waves, a clear pulse that would have mirrored the same pulse given off by the hydraulic ram quickly rose to a very clear ultrasonic pulse half-way up the *optic condenser* (pyramid cone) which is designed to refract photons into a concentrated beam. Think *laser*. Or more precisely, *Saser*.

SYNCHROTRON PHOTOCATHODE WAVEGUIDES

As covered, a magnetron uses multiple chambers to generate a compounded ultrasonic wave field, not completely unlike a synchrotron, which simply uses secondary emission amplification in a slightly different fashion. In scalar ultrasonic wave technology, sharp edges also interact with the frequency waves, each then

Cheops SPOKE Pt 2

generating its own resonance field which is then directed through a *photocathode waveguide*. The guide can be cone-shaped, focusing the wave to a directed point (such as the convex peak of a sphere or needlepoint of a sharp peak), or it can be gabled (a rafter-shape) that directs the wave on an angular pattern that controls the flow to mediate the materials ahead of it.

With such technology, secret militaries can see around corners, see through concrete and stone walls, and bounce the signal off of patterns such as right-angled planar surfaces. This is because light bends around obstacles in what is known as *diffraction*. And energy is factually light. Bending these waves allows otherwise solid obstructions to become their own resonance “chambers” (fields) – on the same principal as the cylindrical sonic chambers inside a magnetron. This is not everyday magnetron technology employed by a simple microwave oven:

*Pakistan Defense: Carpet Cloak Waveguide
Plasmonics;*

*“Unique metamaterials preserve phase while
guiding surface waves around ultrasharp corners
and bumps:*

RADIANT ENERGY TRANSPONDERS

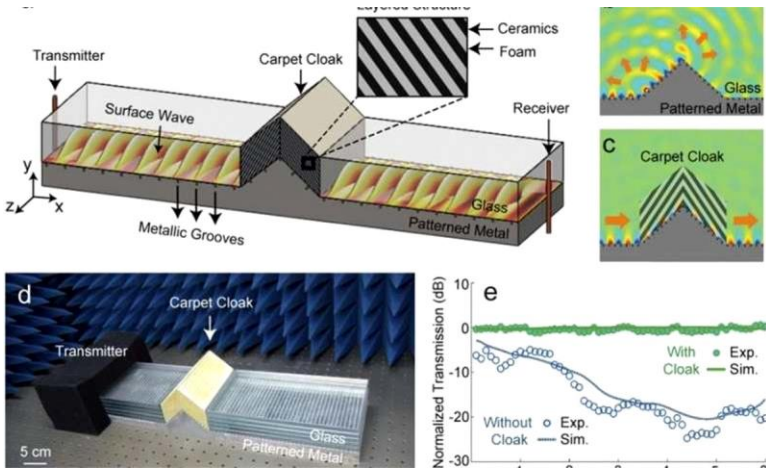

“...to guide surface electromagnetic waves around disorder, such as ultrasharp corners and bumps, without disturbing the wave amplitude or phase.that is, when electromagnetic radiation or particles are deflected or diffused by localized non-uniformities in the medium through which that radiation is passing....”

By using a closed-cone gable waveguide to direct ultrasonic photon particles, the sharp corners of the obstructions become resonators, or unidirectional peaks to the wave as it travels. Cheops' core isn't hollow, but rather nearly 100% solid stone, with strategically-placed resonance chambers surrounded by a continuously spiraling sonic chamber inside. Otherwise, the Great Pyramid is like a solid mountain of *piezoelectric, paramagnetic, dielectric* stone with finely-polished planar rafters over the chambers nested inside that are in every way pure “ceramic material”. Since piezoelectric energy travels through crystal *as its natural conductor*, this isn't a deterrent for the energy, but rather an exponential supercharging of its signal. The inside

Cheops SPOKE Pt 2

right-angles of each limestone casing creates the exact same step pattern across the entire outside surface of the pyramid as used in the glass patterned material directly to each side of the waveguides, and as you recall now, limestone under direct sunlight is ultrasonically-speaking, equated to glass:

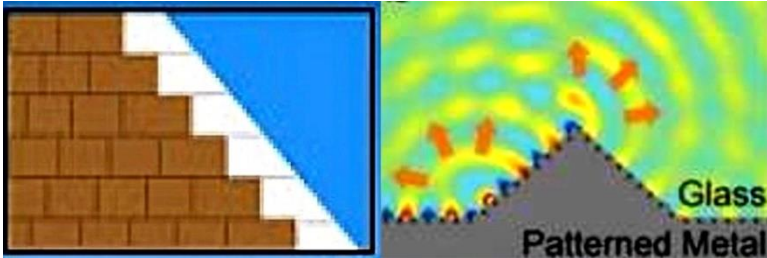

Directly over the lower *photocathode* of the Queen's chamber, and directly over the upper photocathode of the King's chamber, just so happens to be massive ultrasonic waveguides made of *highly-polished* Aswan granite, turning its surface into glass (remember glass is crystal and the granite stones over both chambers are filled edge-to-edge with highly compressed quartz crystal):

RADIANT ENERGY TRANSPONDERS

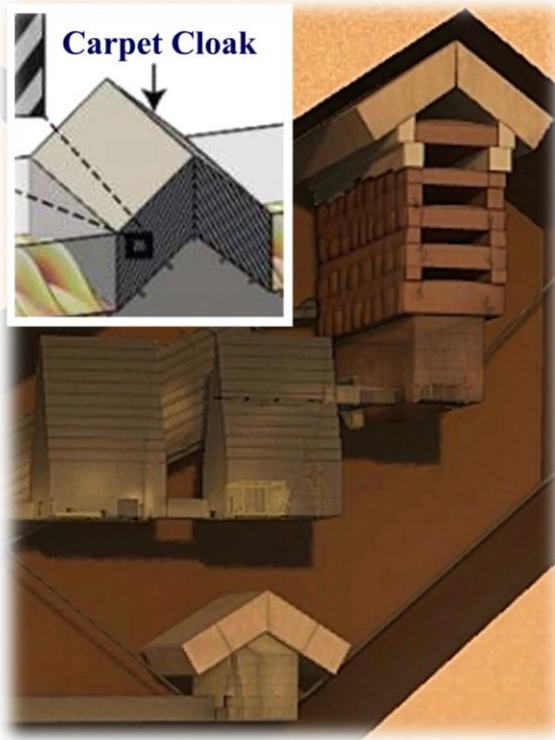

Below the waveguides sit the crystal-charged “spark plug” cathodes that supercharge the flow of the energy once the waves reach the upper stone structures from the subterranean magnetrons. Sonically accelerating the frequencies of the supercharging crystals in the center of the King’s chamber room (the primary signal for the carrier wave), there are five *localized ultrasonic sound chambers* exponentially-increasing in size leading up to the *piezoelectric accelerometer* (we are getting to in a moment).

Cheops SPOKE Pt 2

While the five localized resonance chambers below the King's Chamber gable waveguides shown in this graphic above seem perfectly flat, they're not. Throughout the pyramid, highly-polished stone is continuously used with the exception of smooth but unpolished surfaces wherever they are of no importance. But rather than smooth or polished, for some unknown reason, these particular stones that create these chambers are not only unpolished, but they are inexplicably uneven on their surfaces pointing upward, as well as being made up of many slabs of stone pressed together. And curiously, they are for some reason smooth and polished on the sides pointing downward.

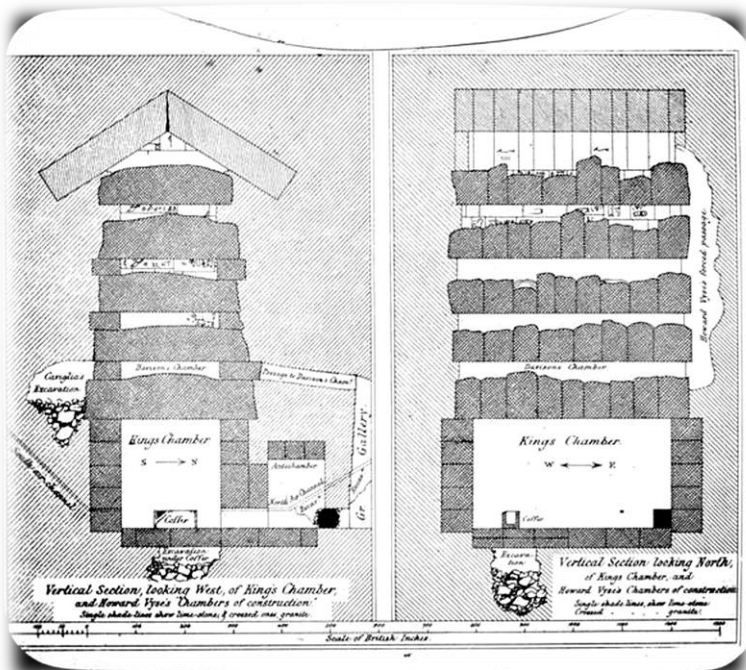

RADIANT ENERGY TRANSPONDERS

In the most precisely-constructed building on Urth that can be equated to a mountain-sized Swiss watch in every aspect of its construction, it would be quixotic to imagine this was by sheer accident or due to mistake. In the carefully dimensioned, mechanically-drawn schematic above, you can see that not only were the tops of these stones deliberately uneven, but each rafter was also different heights, with angles pointing in different directions. Unlike the modern carpet-cloak waveguide where the chevron's surface is patterned to diffract the waves, these resonance chambers directed the waves from each chamber in precise directions to reach each targeted right-angle of the eight corners of the two nested pyramids which would be amplified by the waveguide.

More than just this, the hall connecting the Queen's chamber to the King's has an additional waveguide (now incorrectly assumed to be an "entrance" to the synchrotron) to combine their two oscillating waves (the dual pair of high and low pitches that create the square wave pattern that now bounces off the corners of each pyramid like teeth in a gear which generates a pulsating ultrasonic frequency field chamber in each *diffraction concussion*, exactly like the chamber cylinders of a magnetron):

Cheops SPOKE Pt 2

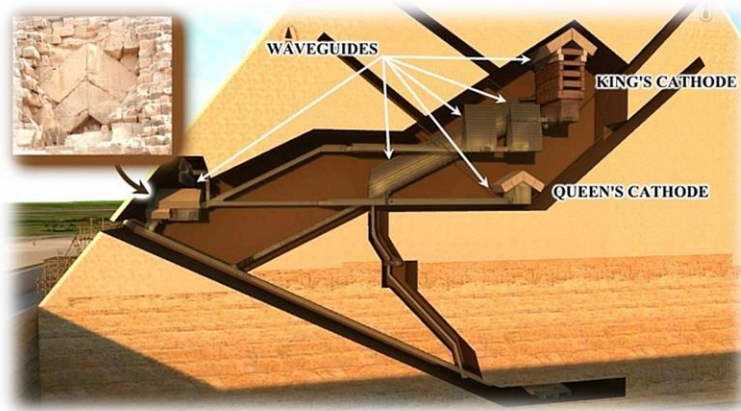

As you can see above, there are additional waveguides pitched over the Grand Hall, and at the end of the chambers between the King and Queen's as well. The deflection chevrons of the waveguides in the King and Queen's chambers face front-to-back, while the four Grand Hall waveguides (offset to their left) face side-to-side, covering a scattering dispensation to all corners and highly polished "glass" planar surfaces of the two nested pyramids. Though impossible to prove, if you were to remove the stones covering the face of the interior pyramid, you would see the outside edges of those steps would be just as polished as the limestone that once encased the main structure, or you would find a complete second white limestone casing around that one as well.

It is more than just a simple coincidence that the precise angle of the gable waveguides of the King and Queen's Chambers are not on a parallel to the outside surface of the upper structures, but are much less inclined, considering the

RADIANT ENERGY TRANSPONDERS

impedance conversion of piezoelectricity (ICP) circuit inside a *piezoelectric accelerometer* (the relaxed pyramid shape) is the **actual symbol** for *change in pressure* of such a signal. As the massive cache of precisely-combined and tuned crystals that once had been inside each photocathode “sarcophagus” provided the signal frequency to increase the velocity and output of the magnitude (energy force) would be amplified and scattered into the seismic mass above at key points within the ever-concentrating (accelerating) field. Note this Piezoelectric Accelerometer is fitted with an Optical Condenser that matches the incline of the waveguides above:

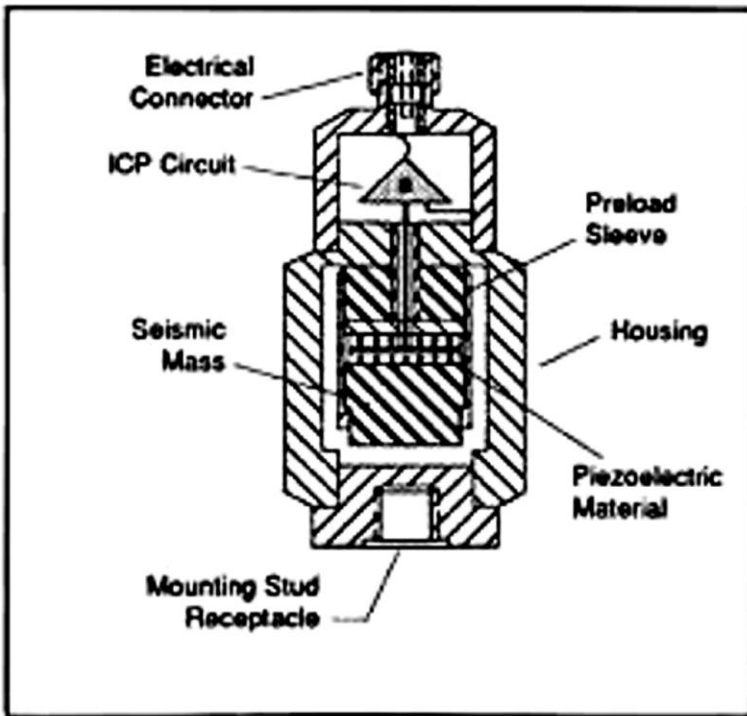

Piezoelectric Accelerometer

DIORITE OMNIDIRECTIONAL CHIRAL SUPERCONDUCTOR

In 1872, engineer **Whaynman** and brother **John Dixon** traveled to Cheops to investigate further the secrets of the Great Pyramid. In this process they discovered a strange sphere wedged into the airshaft of the Queen's chamber:



“Traditional” superconductors cannot be made without the graphite and graphene content found in stones such as limestone, quartzite or **diorite**. However, the new Dirac (D-Wave) *Chiral superconductors* that are suspected of

RADIANT ENERGY TRANSPONDERS

working at **room temperature** specifically require the **mica** within that graphene. Diorite carries properties of magnetite, allowing it to generate its own magnetic field with mica D-wave pairing for its tunneling conductance from the monopoles within its crystal lattice, making diorite contents highly sought after right now in the pursuit of true superconductors. This has led to research inclusion of coating of the mica flakes with finely-powdered **Bismuth**, seeking “*zero-bias conductance peak for Cooper Pairing and Meissner Fields without use of any external magnetic fields or electrical input*”. In other words, a *geopolymer rock* that simply is a room temperature superconductor:

***Diorite:** (Orocopia Schist);*

*“Mostly grey, fine-grained quartz-feldspar-**mica** schist, with sparse **metaBasalt** and metachert.”*

*(Pyroxene) “Common accessory minerals include titanite, **magnetite**, apatite, and trace amounts of pyrite.” [pyrite is iron, a natural “super” ion conductor]*

DEUTERIUM PHOTON ACCELERATOR

In the ceiling of the hydroduct chamber is a square hole that has now been compacted with sand and soil over millennia of desert dust filling up the hydroduct room and

Cheops SPOKE Pt 2

calcifying. When the room was excavated, only a small recess into the hole was removed:



In the Queen's chamber positioned directly above this room on a slight angle away from the magnetron chamber that lies between the two rooms there is also a hole in the floor, showing that there was a shaft connecting the two. This has been explained by marine engineer John Cadman as having been a *ventilation* shaft for the hydrogen gasses that would certainly build up from the concussion of the hydraulic pump splitting the hydrogen from the oxygen in the water, otherwise filling up inside the hydroduct room. In normal hydraulic ram pump applications, these gasses are ventilated by an additional pipe you see going off to the left at the top of the pump assembly as shown below in the illustration on the right.

RADIANT ENERGY TRANSPONDERS

The water from the underground reservoir is pulled up from the vertical shaft found just below Cheop's hydroduct room by the hydraulic ram pump. From there, the hydrogen is separated from the water (this is the chemical element in massive abundance inside Deuterium prior to reaching sunlight) through fractalization from the sonic concussion. The heavy water is then pushed into this large water chamber already full from the ancient lake, past the electrostatic generator and then pushed on likely for irrigation purposes or a well, or even to the Nile through the line already existing but as-of-yet not cleared called "the dead end shaft" that travels 57' due south. The hydrogen then naturally rises through the body of water and the square opening at the top of the hydroduct room and into the Queen's chamber:

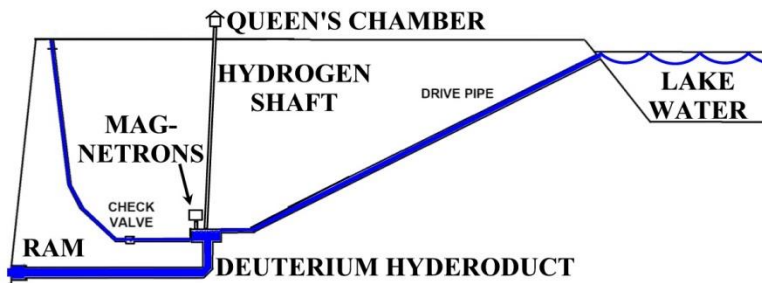

The image on the left below shows how Cheops' hydroduct room is designed, and the right shows how typical pump systems work to release these gasses. Cheops' waste water lost during each pulsation of the ram pump went directly out of the *dead end shaft*, but specifically not the gas, as it only collects at the top of the water body and not at the

Cheops SPOKE Pt 2

bottom where the output line notated below “TO NILE” is located:

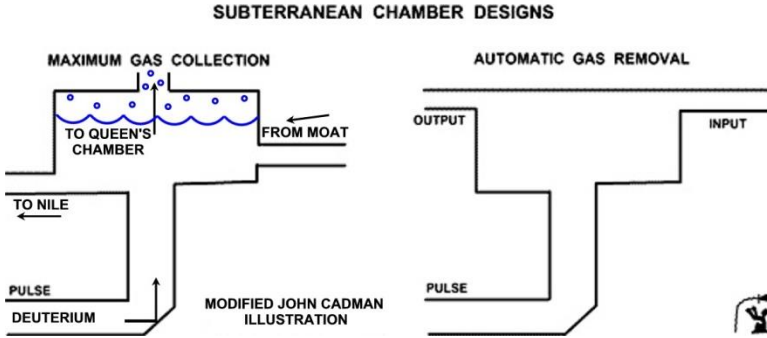

Also above, you can see the 45 degree angled elbow that was used in the lower Deuterium well where the pulse is generated by the pump leading up to the main chamber where the stator posts and sarcophagus electrostatic magnet are located.

Cadman also pointed out that in ancient indigenous teaching; “*hydrogen gas was used in the Queen’s chamber for some reason*”, though this was never explained. However the gas absolutely would have been present there, since ram pumps automatically generate the splitting of the gas from the liquid of water. The liquid of water holds the Aniline crystals that manufacture oxygen once it reaches sunlight, and the gas released from “photosynthesis splitting” is hydrogen that rises. Therefore, only the hydrogen gas would enter into the Queen’s chamber. If any oxygen were to follow the hydrogen, it would be repelled

RADIANT ENERGY TRANSPONDERS

back down the shaft by what we are about to cover in a moment. Here is a look from Cadman's notes on how his pump followed the precise details of Cheops' layout connecting the rooms. He was mistaken that the water to the ram pump came from the Nile, so you will see a difference between his illustration below and those I have simply modified previously shown:

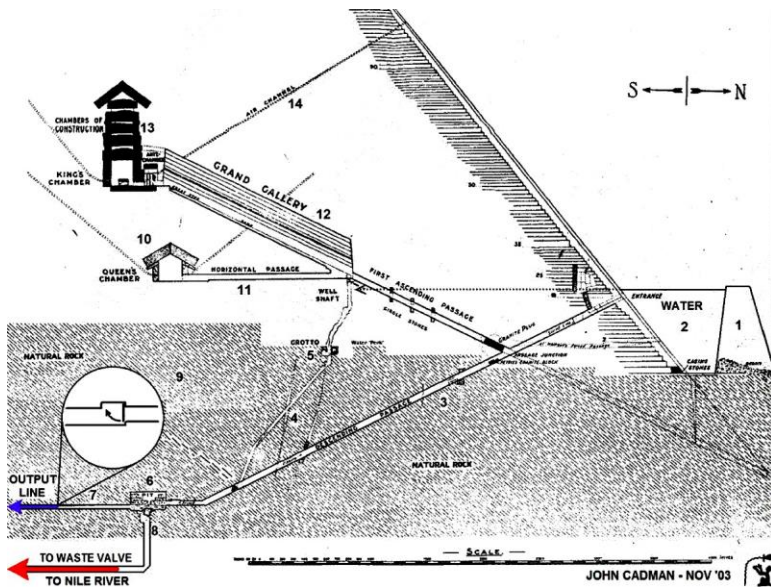

QUEEN'S CHAMBER AIR SHAFTS

In the Queen's chamber at the now-filled-in hole in the floor at the arrow above in the graphic, there were extra heavy salt deposits around the edges, and there were heavy salt deposits on the walls, ceiling and floor of the chamber,

Cheops SPOKE Pt 2

indicating that there was absolutely a salt mist presence. Meaning there is no chance that the water in the subterranean room wasn't rich with salt and there is no chance that the gasses produced by the pump weren't used in that room. We know that these deposits did not come from the pyramid being submerged in ocean water at some point, since this and lower causeway corridors below were the only ones found with such salt deposits throughout the Great Pyramid, and of these, only the Queen's chamber was deeply calcified.

Now recall that the air shafts going to the Queen's chamber were not open all the way to the outside of the pyramids. At the bottom of one of the two shafts was found wedged inside a diorite sphere. Both of these shafts had been plugged by limestones blocks that were not part of the original structure, but sloppy enough to allow drafts of air to resonate from the chamber inside, leading to their removal for inspection in the late 1800s. At the time the openings were deliberately fit with plugs meant to camouflage the shafts, more than likely an identical sphere had been removed from the opposite shaft prior to their capping.

More than this, in the center of the corbeled niche of the Queen's chamber was traditioned to have originally been found a statue made of diorite. Diorite, as already discussed, is one of the hardest stones known to man, not far below diamond, and definitely harder than granite. The spheres as well as the statue would have been impossible to shape with anything other than diamond or laser tools, and even then, making round spheres would have presented its

RADIANT ENERGY TRANSPONDERS

own very complex and difficult challenges. They were not made by accident, nor did they fall into these shafts and get stuck.

The statue of the same material would have been equally difficult to make, yet that's what ancient accounts report as having been in the chamber, inside the slightly offset niche that had four 90 degree planar corbels directly above along each side. Now recall that diorite is a *natural Chiral superconductor*, thanks to its content of mica as well as magnetite. Note the air shaft to the right and also the opening down to the hydroduct room in the floor in front of and traveling inside the niche:



The Queen's chamber is lined entirely in finely polished limestone below the salt deposits, identical to the "air

Cheops SPOKE Pt 2

shafts". Inside those shafts multiple expeditions have been carried out over the years. In 1993, a specially-built robot was used to enter the small opening in the southern shaft and a wall was found blocking the way 65 meters up that was fitted with two copper posts. The same distance up the northern shaft yielded an identical wall also fitted with two copper posts. Here is an image of the North Shaft end:



Here is a look at the end of the South Shaft:

RADIANT ENERGY TRANSPONDERS

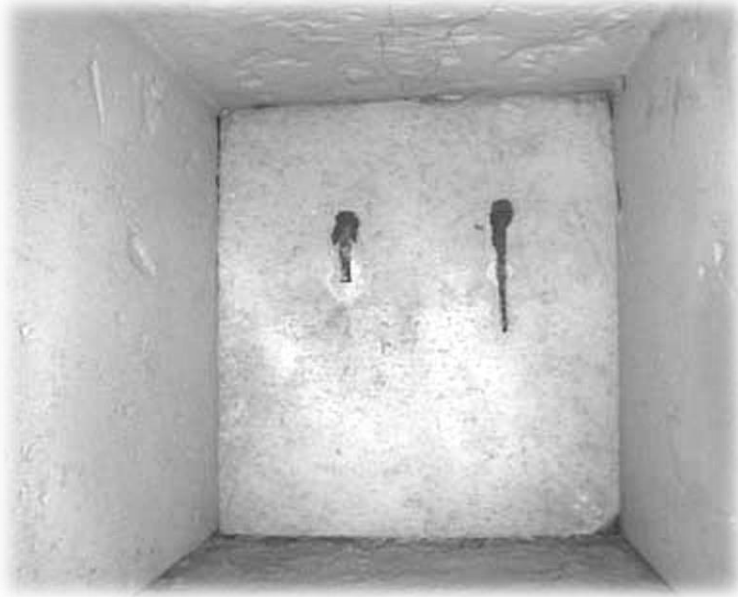

As is evident from the images, both shafts were lined entirely in limestone, and both shafts ended with dual copper posts. Interesting, because the majority of Cheops is built out of granite. Why take the time and trouble to line this room and these shafts with a different, softer material? Was it to deflect the light coming in from some star system for “spiritual alignment” that would allow a spirit essence to pass through for ascension? Not with many feet of stone blocking them off if your idea is that somehow a spirit can’t travel through walls all of a sudden.

There are clear markings on the limestone around all four copper posts to indicate trace *photosynthesis*. There are limestone flakes all along the floor of both shafts, exactly what would result from the chamber’s surface stress when

Cheops SPOKE Pt 2

exposed to a chemical reaction, such as when in the presence of high electrical current. One of the copper posts has been cut off somehow. More than likely this was during a secret research experiment to determine the type of metal that was found. But there is no evidence of thermal radiation. What we are seeing is the same thing left behind when neutrino tau leptons were captured in the 1997, **Firmilab Donut Experiment**, that etched *photo tracing* such as left behind on photographic film as photon tracks.

The entire Queen's chamber had originally been *sealed* to passage according to experts. This is significant, as you will soon understand. As you can clearly see below, the air shafts at each side of the Queen's chamber are opposite one another, directly centered to the elevation of the statue inside the niche and are also sealed to outside open air, creating a vacuum with the one exception of the hole in the floor feeding the hydrogen gas from below:

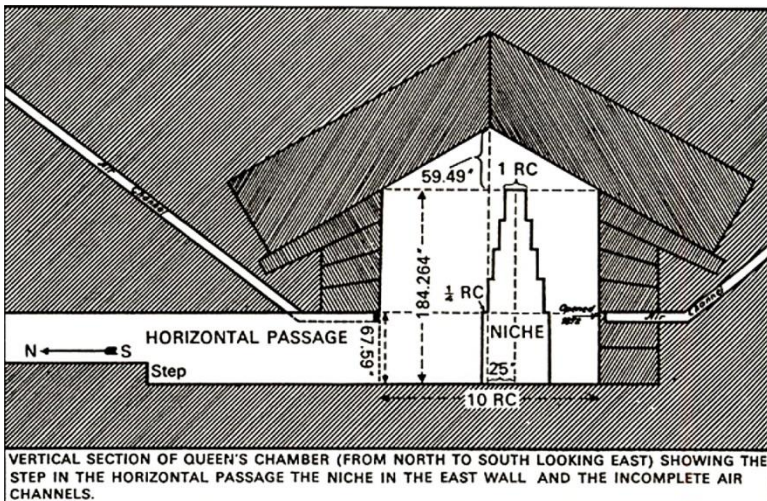

RADIANT ENERGY TRANSPONDERS

Had the copper rods at the ends of both shafts triggered a reaction with the hydrogen, the diorite spheres at the bottom of the shafts would have naturally become “extender” dielectric photocathodes which were coincidentally perfectly aligned to the center of the superconductor diorite statue to strengthen the connection to continue that reaction with the hydrogen now intensely saturated throughout the shafts and main chamber.

COLD CATHODE GAS DISCHARGE LAMPS

Cold cathode gas discharge lamps, better known as **neon lights**, use hydrogen, argon and mercury to produce **red ultraviolet light**. The purest form of hydrogen (least amount of contaminants which means “oxygen-free”) is produced from “*underground water that has never entered open air and has been shielded by rock*” according to Wikipedia, such as the *underground reservoir of Deuterium* that has traveled from Urth’s core *through “glass-like” shielding limestone*.

Little known is the fact that hydrogen just so happens to merely be another name for the broader term of *Deuterium gas* that also included nitrogen, oxygen, argon, hydrogen and carbon. In fact, during the 1800s, neon lights were first known as “*Deuterium lamps*”:

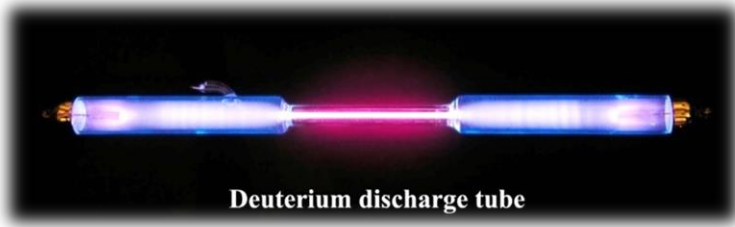

Prior to the sealed tubes introduced in the late 1800s as Deuterium lamps, Deuterium and limestone had been used for illumination for more than 50 years. In 1836, during Clocktower celebrations in *Herne Bay* in Kent, England, Deuterium gas produced a small flame that then heated up a *limestone cone* which then created an incredibly brilliant light for the actors on stage during the festivities. So limestone and Deuterium literally goes back to the very first days of using something other than mere flame to create illumination. Much later, Deuterium gas would be simply termed “hydrogen” as the more purified essence of that energy. Today the bright light produced by the original **Deuterium limestone lamp** is referred affectionately as a “*Limelight*”.

The nature of hydrogen that has had its covalent bonding broken from oxygen (such as from sonic pulse fractalization of water) is to displace the “heavier” of the two, forcing oxygen downward (such as down the shaft at the hydroduct room) now sealing the entire Queen’s chamber and shafts from any level of oxygen presence. It also has the unique capacity to nullify any expanded dark matter signatures in a field, absorbing that energy and forcing the “red wire” of ion energy to the deepest portion

RADIANT ENERGY TRANSPONDERS

of its insulating valence within the Aniline crystals in the air. This effect is known as *light scintillation*. Realize that hydrogen is the primary gas released from water, and inside that gas are other individual gasses, such as argon as mentioned above. Argon *absorbs radiation*, hence why a hydrogen-powered **cold cathode** gas discharge lamp remains cold when its power supply is regulated:

Wikipedia: Argon;

*“Argon is used in some high-temperature industrial processes where ordinarily **non-reactive substances become reactive**. For example, an argon atmosphere is used in graphite electric furnaces to prevent the graphite from burning.”*

So while there is an electrical reaction produced inside argon to the mercury atoms that cause a neon or fluorescent light wave, argon insulates that signature of any thermal radiation as long as the power is regulated going to the reaction. But it does more than just that; it literally turns the ions that could now be showing any signs of inversion into Dark Matter back into Triplet State. As you know by now, Triplet Spin State is the state of **light**, neutrinos, bosons and is the “god particle” that suspends natural Standard Model laws of physics. Triplet state is just another word for Cooper Pairing that reverses Dark Matter electrons into Light Matter ions.

Now realize that the tau lepton side of neutrinos that is the force that *produces* photosynthesis has been identified as

Cheops SPOKE Pt 2

the “essence” of an anion ion, or the *incredibly strong force* 3500 times stronger than an electron. It is the very essence of the type of power that has been babied from a handful of photons within the water below Cheops, moved by a sonic wave and turned into millions of phonons by the time it has reach the Queen’s chamber.

The hydrogen created by the sonic pulse generator in the hydroduct room is produced 100% by Deuterium that has never seen the light of day, as it is heavy water and while it was inside the shaft running up from beneath the hydroduct room, zero lake water would have been able to mix together with the Deuterium, as heavy water bodies are like solid ground to lake water and the two simply separate like oil and water until they are “shaken” together such as in powerful ocean waves. This means only the purest form of “hydrogen” that would include argon and mercury would have emitted from this room where there would be zero oxygen.

Ultra-pure hydrogen carrying its complex compounds which are all used in photo and light-emitting applications that can only be extracted from water that has been encased in a body inside of pure rock is used in light scintillation. This is the process identified above of absorbing radiation. By now you also know that radiation is also just another word for Dark Matter, or inverted ions. And Dark Matter is just another word for heat. So the waves that have been supercharged by the excitement of the electrified signal from the hydroduct generator inside the magnetrons below, reach the Queen’s room in order to begin the second

RADIANT ENERGY TRANSPONDERS

process of synchrotron amplification that up until now had been carrying an electric ultrasonic signature. That signature has to change slightly in parity in order for the second stage to deal in nothing but photon light energy, but only after it has been used to create *ultraviolet light*. Light scintillation then processes those tau neutrinos through the mass of piezoelectric stone above in “Cooper Pairs”. Which is why we now have multiple superconductors at the very first stage of the synchrotrons.

A CCFL (Cold Cathode Fluorescent Lamp) neon light bulb has a set of cathode and anode points also referred to as simply “electrodes” at the ends of the tube. Inside the tube is hydrogen gas with traces of mercury. Like fluorescent lamps, a cold cathode discharge lamp excites the gas that produces light waves, but unlike fluorescent lights, it is not using radiation to achieve this, it is using balanced photons which transfer energy through dielectric permittivity, not through electromagnetic conductance which is why the tube and the electrodes remain cool, even as the trillions of tiny “explosions” are going on. Hence, why this is referred to as COLD cathode:

Cheops SPOKE Pt 2

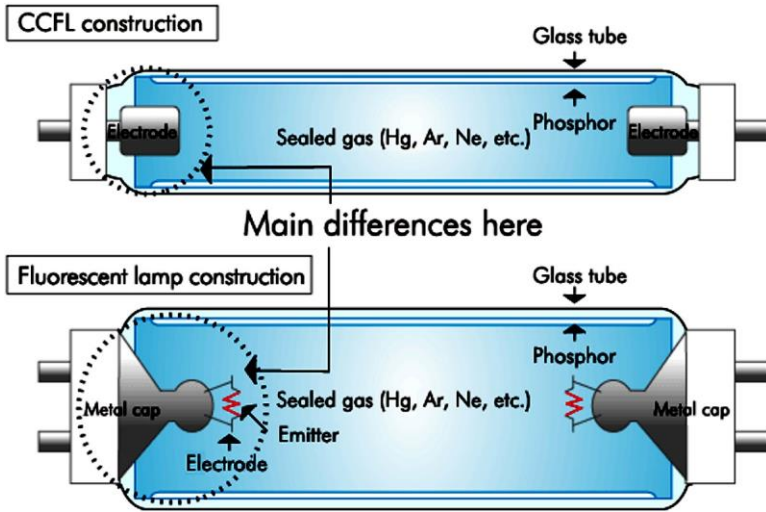

A cold cathode gas discharge lamp must regulate the energy going into the neon light after it has begun the process of illumination, otherwise that super-high electric current will overpower the now-excited photons, generating heat which will cause the system to self-destruct. A ballast is needed to regulate this flow so the light can continue without a thermal signature.

In 2002, **Rudolph Gantenbrink** performed another robotic expedition up the air shafts in the Queen's chamber where he intended to drill a hole through the cathode/anode wall in order to use a video probe to see what was on the other side. Curiously he found yet another wall of limestone a short distance away from the first wall. This was a *ballast chamber*:

RADIANT ENERGY TRANSPONDERS

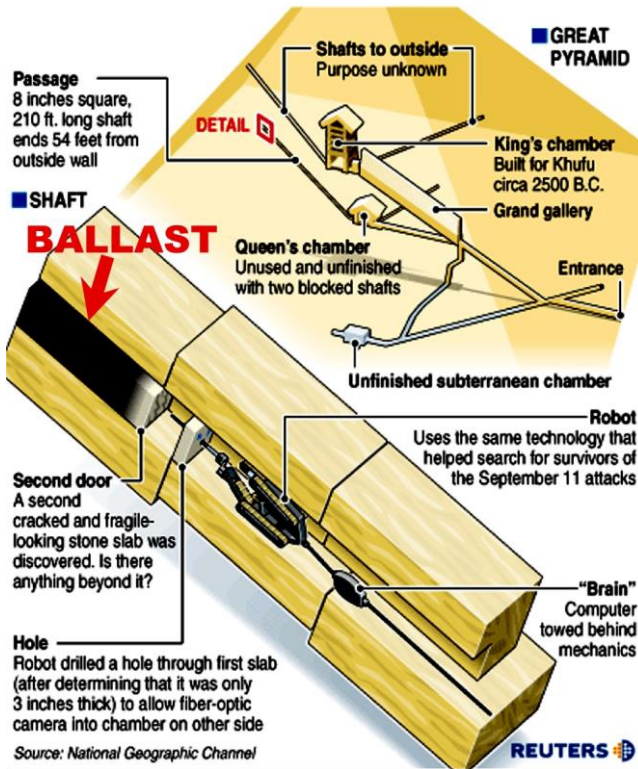

The copper posts found on “Gantenbrink’s Door” were deliberately inserted through the limestone wall and into the empty chamber behind in a decidedly finished fashion to allow clear heat transfer:

Cheops SPOKE Pt 2

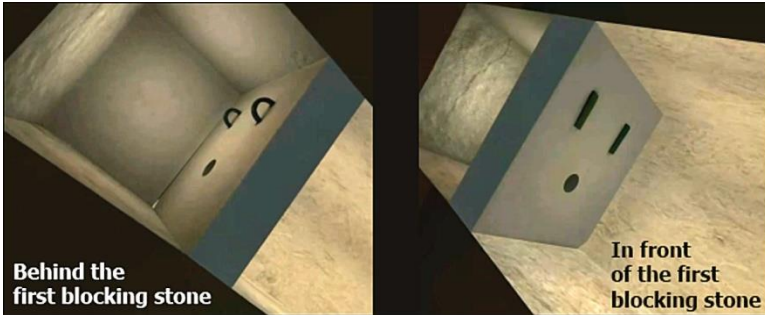

The power to begin a gas discharge lamp is a very high electric field and does not require wire connecting the two electrodes together. The glass tube of the cold cathode gas discharge lamp (remember, limestone ever exposed to sunlight is glass) must be coated with phosphorus. Phosphorus comes from limestone. This makes the air shafts in the Queen's room literally cold cathode discharge tubes with zero oxygen in the air and filled with the purest form of Deuterium gas possible. Each one was also fitted with both of the two electrodes needed to begin the activation and backed with these empty chamber ballasts that have been directly ported with thermal conductors in the form of two copper posts apiece.

Natural Tura limestone carries mercury in its mineral makeup, which is the secret to the phosphor needed to begin a *hydrogen thermionic reaction*. Once this reaction is induced through high static electrical flow, the reluctance between mercury and hydrogen breaks down, generating brilliant light. This chemical reaction produces a small amount of heat which begins to warm up the air. That heat transfers through the posts in Gantenbrink's door, into the

RADIANT ENERGY TRANSPONDERS

ballast chambers which have been noted as being cracked by that very signature. This heats up the air inside the ballast chamber which *decreases the electrical permittivity of the stone* which lowers the dielectric transfer of energy to the posts, thus lowering the current and keeping all the light produced by the mercury/Deuterium ultraviolet light cool.

In other words, generating perpetual **cold fusion energy**. In a radiation field, the higher temperature would only increase the flow of Dark Matter electrons, but within a dielectric field, it would have the opposite effect.

The *antiparticle* of hydrogen/Deuterium gas is the *only particle ever identified* as of 2015 to operate as a **monoatomic gas** merely by being just below 73.4 degrees Fahrenheit (room temperature). The rest of diatomic gasses must all be brought down to *cryogenic temperature* in order to achieve this same status. “Cryogenic” means temperatures just above absolute zero. You will recall now that this is the very same temperature claimed is required for modern-day superconductors to process Dark Matter electrons. The temperature inside Cheops remains at 68 degrees year-around which is close to 6 degrees below room temperature. Not only was the Queen’s chamber fitted with 3 room-temperature chiral superconductors whose unified field had been amplified into a gigantic superconductor by the enormous discharge of cold fusion Deuterium ultraviolet light energy, but the very substance that produced that cold light was generating its own

Cheops SPOKE Pt 2

monoatomic gas, known in quantum science as *Triplet State zero-spin*, exactly like monoatomic gold.

The Queen's chamber, besides being other things, was in fact a Deuterium gas lamp that used ultraviolet light to turn electrified phonon sound waves into photon light waves. The ***red neon light waves*** permeated the stone blocks above the subterranean rooms now in neutrino fashion where they are able to pass through any thickness of dense matter, because they are now in Cooper Pair status, or Triplet Boson State. This massive light would be something on the order of a small sun, as clearly reported by the Sumerians when "*Enlil with his own hand the Nibiru crystals activated*" resulting in a "*mesmerizing hum*" according to later historical reports and "***Its interior with a reddish light of heaven glows.***"

CHAPTER 20

RADIANT ENERGY TRANSPONDERS

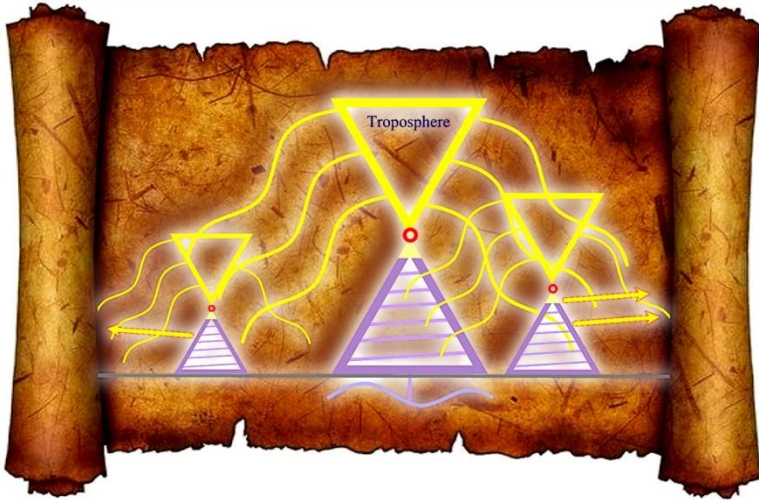

In the first phase of energy generation, we learned that the slamming gate of the hydraulic ram pump created a wave of sonic pulsation that split the Deuterium heavy water producing ultra-pure hydrogen/argon for the Queen's chamber's ultraviolet neon superconductor while the sonic pulse also flowed through the electrolyte conductive water in the hydroduct chamber, gathered up the free-flowing ions from the liquid glass crystal box and the four stator posts, then pushed those energy ions through the water solution directly away from the sonic source situated at the

Cheops SPOKE Pt 2

bottom of the solution and forced the dual-phase, nested electrostatic waves in a straight path through Shaft 3 into the additional 7 resonance chambers of the two magnetrons at Level 2.

The ions within the two distinctly unique but resonant input wave and carrier wave phase signals then are filtered out and directed into each of the two photocathode crystal and monoatomic gold resonant inductive couplers into their respective magnetrons to create two different ultrasonic square waves in zero-point, time-suspended Meissner Fields that would now be amplified by the resonant inductive coupler chambers, amplified again and now in superballistic form by the sonic resonance chambers surrounding the couplers and the room itself then became a collective ultrasonic resonance chamber that pushes the magnified waves upward once again to the levels above, due to the electrostatic magnetic field generated by the outflowing anion ions turning all the iron-laced lattice crystals inside the paramagnetic walls, floor and ceiling of that limestone chamber in the same direction they were already traveling, which was straight up in a clockwise oscillating pair of nested square waves.

The paired waves would then move directly through the remaining 80 feet of stone above unimpeded by the fact that it is solid piezoelectric, dielectric, paramagnetic natural limestone that has never reached direct sunlight to cause it to lose its original paramagnetism which resonates as a single molecular composition through network covalent bonding and now held within a zero-point Meissner Field,

RADIANT ENERGY TRANSPONDERS

allowing that stone to become one with the superconductor. The electricity now flowing from the room 98 feet below ground has already reached the dual synchrotrons above 3 seconds before it began generating through the Double Slit unified field. Now our square waves will enter into the next phase of their multi-stage journey from electrostatic phonons to atmospheric photon ionization of the canopy over the Cheops energy complex that will reach possibly hundreds of miles in every direction.

The velocities and intensities of the waves have now increased by one million times from what they were before they reached the first set of ultrasonic magnetron resonant inductive coupler chambers following the path of the golden spiral, passing through the magnetron chambers, into the Queen's chamber and finally into the King's chamber:

CHEOPS

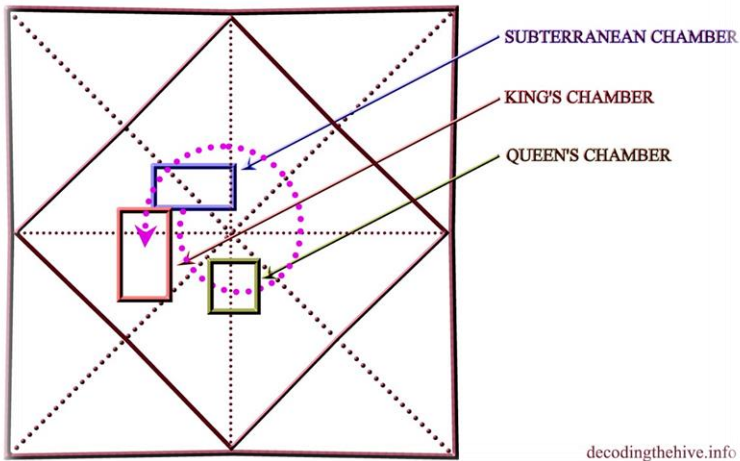

Now we take a closer look at the dual synchrotrons of the pyramids themselves.

D WAVE CONTROL TEMPLE

When crystals are infused with high levels of photons, it generates a cascade of tiny sparks below the unaided visible spectrum, similar to how Dark Matter electrons spark wildly between the layers of ferro-metal conductor plates inside power line transformers where they do not create red, but rather grey sparks at the microscopic level. The oil inside is emulating the insulating effect of the valence layers of crystals in order to keep the sparks from

RADIANT ENERGY TRANSPONDERS

reaching open air and the resulting thermal signature from igniting the device.

The same micro explosions generated by photosynthesis in a crystal are called *ion beams*. The extreme flow of anion ions coursing through the Energy Temple strikes the same harmonic frequency note as generated by the sun, generating totally enclosed sparks that under a microscope appears as a silver grey as shown below in this microscopy of a quartz crystal. This is known as *fusion* in particle science, but is factually a fission/fusion reaction where it does have a thermal signature, but that heat is regulated by the extreme thermal conductivity of the valence bands of the crystal. In a more contemporary term, you are literally looking here at *cold fusion*:

Cheops SPOKE Pt 2

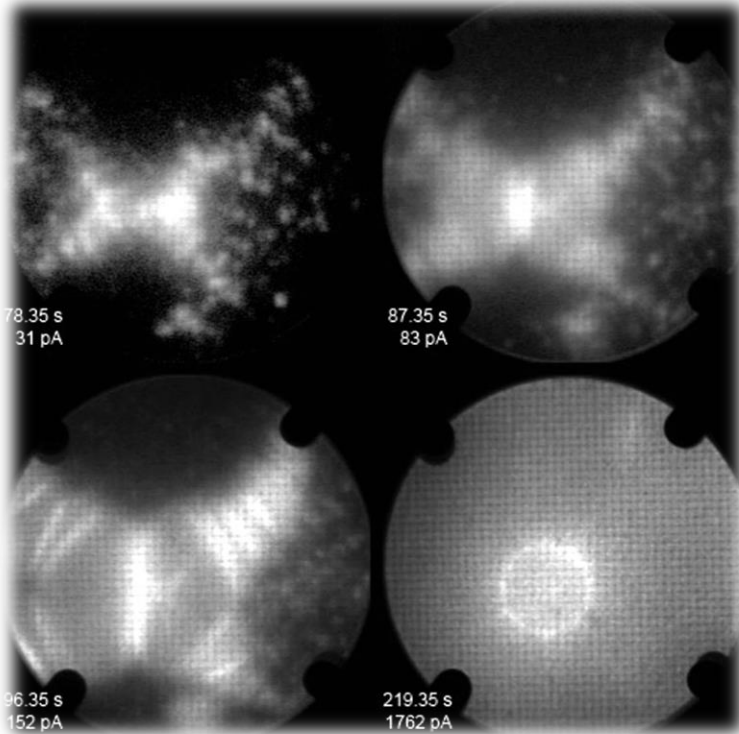

Crystals carrying piezoelectric signatures are also called *pyroelectric* for this reason. When the crystals heat up inside that inductive coupler chamber, it elevates the temperature of the monoatomic gold ormsu to reach a Meissner Field, a fraction of a degree below the point where it vanishes from view. This field combines with the diorite neon-light superconductor field in the Queen's chamber and air shafts and supercharged by the Deuterium/hydrogen monoatomic phosphorescent gas, and the same Meissner field generated in the King's chamber by the deep red dolerite/Basalt resonant inductive coupler filled with the same monoatomic gold and piezoelectric crystals.

RADIANT ENERGY TRANSPONDERS

The now-active superconductors in the two magnetrons below, along with the now-active superconductors in the two synchrotrons above combine in perfect resonance. The neon ultraviolet light produced in the first synchrotron boosts its respective signal by millions of times in magnitude, as the process of ions crashing into the hydrogen and mercury ionizes the air, producing secondary emissions before they even begin traveling. The waveguides above the superconductor in the niche of this room are also planar secondary emission dynodes right where the center photocathode is located.



Cheops SPOKE Pt 2

The many secondary emission waveguides in place above the two main chambers situated down the Grand Gallery and strategically placed locations broadcasts out that field throughout the Temples, placing both pyramids above ground and equidistant below of solid paramagnetic limestone into one massive Meissner Field. The bottom half of the overall structure is firmly bound by the Giza plateau limestone shelf below, so the pyramids do not suspend off the ground, but the field still remains, turning the entire device into a D wave chiral superconductor.

All mechanical amplification takes place within a zero-point where time and gravity have no application. If the pyramid were to be placed upside-down away from Urth, it would be suspended in the air weightless, quantum-locked at possibly 1/2 of a mile above ground. But that's not why the zero-point Meissner Field is used within the Temples; it is used to perfectly insulate that energy with no possibility of leakage lower than some 480 feet above ground (the pin-point of the pyramidion) where there is no possibility of making a ferromagnetic lightning bolt leap and short-circuiting back down to Urth.

As soon as the very first phase of energy reaches the first synchrotron, the 8 chambers down the shaft of Osiris are already surrounded by an applied magnetic field from the electrolyte solar moat surrounding the base of the pyramids, and merely amplified stronger yet by the magnetrons. This places that beginning energy inside

RADIANT ENERGY TRANSPONDERS

Cooper Pairs, where they will go through each ultrasonic resonance chamber at superballistic speed, millions of times faster than electrostatic conversion. Meaning the ions and Aniline crystals throughout the now-shared atomic crystal lattice vibrating within that radius are now resonating as a *single molecule* through network covalent bonding.

BLACK HOLE VORTEX SASER BEAM

We have long since covered the fact that the intensely dense, super-thermally conductive, super paramagnetic Black Basalt pyramidion is honed to match the organic shape of the massively ion-infused magnetite it holds inside, creating a sharp point where an electric flow must push its way down into a focused Saser beam to travel through. The four edges along the tapered planar sides all act like secondary emission waveguides, amplifying that signal yet again at the point of release. When this incalculable mass of energy finally releases through this point, if there is any thermal signature generated in this epic transition from one inductor to the next (into the air), this would all be scrubbed off by the non-paramagnetic crystals inside the non-magnetic, non-conductor, quartz crystal limestone heatsink between the superconductor and the capstone. The precise size, density and mass of the Basalt would be harmonically tuned to both resonant pyramids below, which then releases the energy.

Cheops SPOKE Pt 2

The function of the optic condenser pyramidion is to insulate the thermal signature of the ions, reduce down the waves into a focused, standing Saser beam, and to function as a black hole as referred to by science. It is a photocathode in technical terms, but nonetheless, acts as a very real vortex where any energy swirling around within the field of its independent, super-magnetic field are automatically sucked in like a vacuum and transduced back into pure, raw, ionic energy.

What then emits the capstone is a photonic Saser beam on an unthinkable scale, filled with trillions of trillions of joules of energy current that will be broadcast into the sky at superballistic speed. The double helix ion waves now recharge all the spent ions from ground level all the way up to the perfectly concave secondary emissions dynode crystal dome firmament where the impact now multiplies that entire signature yet again, producing millions of cubic feet of oxygen spread across the entire canopy above and refracted off of every particle in the atmosphere, from dust to water vapor, sending that energy and oxygen back downwards toward the ground. The Transponder Temples that always surround Control Temples you know now have been tuned to both the first and second phase pulsating square waves through resonant inductive coupling then soak in this energy through *radiant energy harvesting*.

RADIANT ENERGY HARVESTING TRANSPONDER TEMPLES

RADIANT ENERGY TRANSPONDERS

The Giza Plateau has a total of three Control Temple Complexes as shown below. One, Cheops, is a dual phase system; the other two are single phase. Each Control Temple will have a subterranean hydroduct to produce its own initial signature. Each will also have at least one Transponder as well. As seen here, Khufu (Cheops) has 4 to the east, Khafre 1 south, and Menkaure has 3 also to the south. These three would have been situated all together to service an original city that would have been at least 50 to 100 miles across, if not more, hosting an estimated 5 to 10 million residents:

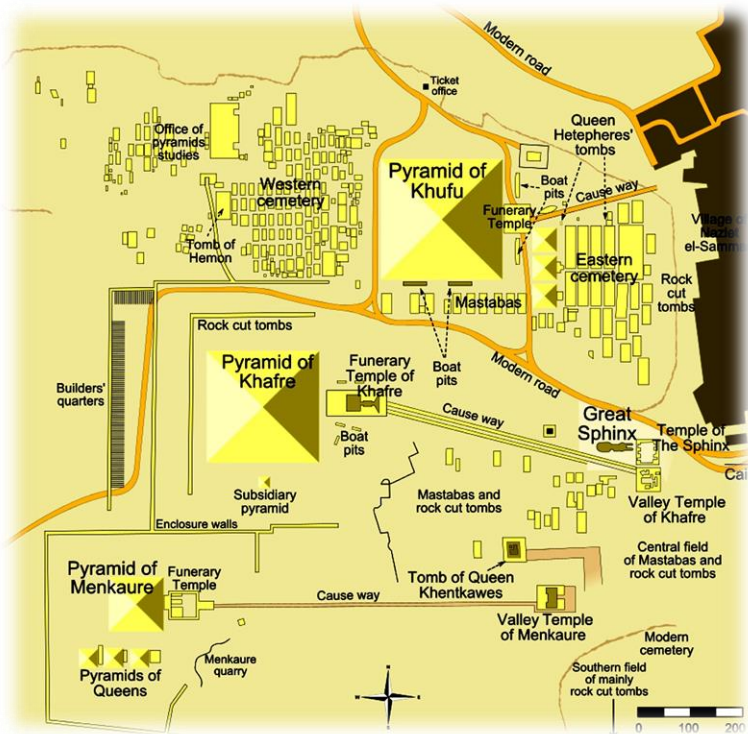

Cheops SPOKE Pt 2

Unlike Cheops, Khafre has just one phase signal, thus one Transponder (at least) was required. You can see the water moat around this slightly smaller Control Temple and its single phase powerplant complete with its own photocathode waveguide clearly depicted:

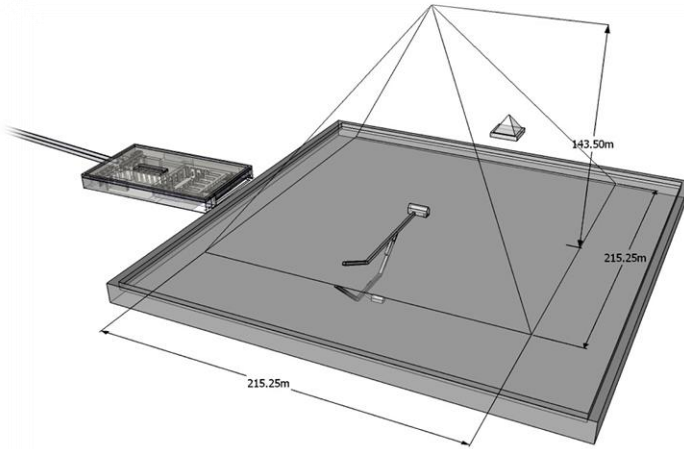

Khafre's synchrotron is situated precisely on center to the pyramidion above rather than offset in the case of both photocathodes and waveguides in Cheops due to the fact Cheops had two nested pyramid Temples, requiring each one to be situated next to its corresponding initial planar surface to begin the spiraling waves. In a single-phase Command Temple the waves are sent out already spiraling to deflect off of all four planar surfaces to continue their journey to the optic condenser vortex above. Here, the sonic signal from the hydraulic compression pump gate is directed above to the photocathode through the sonic wave

RADIANT ENERGY TRANSPONDERS

chamber leading away from the hydroduct through two corresponding-degree planar deflection shields. This chamber was also curiously coated in *limestone* rather than granite. Note how the angle of the waveguide at the photocathode is slightly elevated toward the slope of the secondary emission planes of the cone to send the energy on a decided, precision angle to direct it upwards as it deflects:

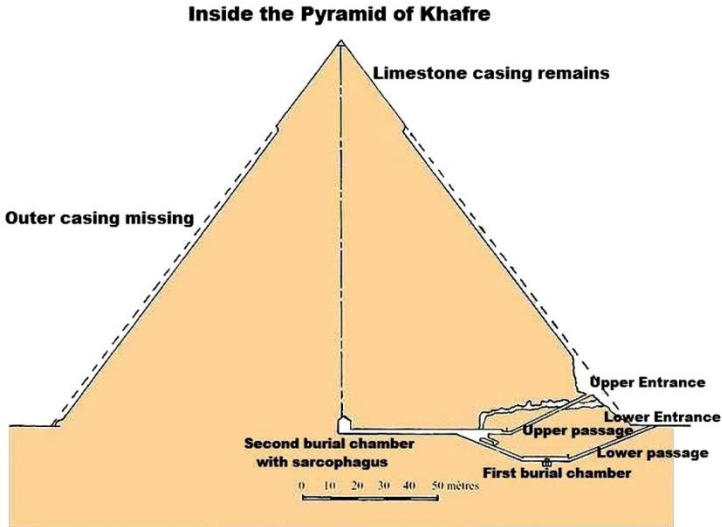

Here is a view of Menkaure's subterranean hydraulic system (illustrated as if it is inside the pyramid, but is actually below), along with its moat walls surrounding the main Temple. While it is a single phase Control Temple, it employs three different Transponders to amplify the signal:

Cheops SPOKE Pt 2

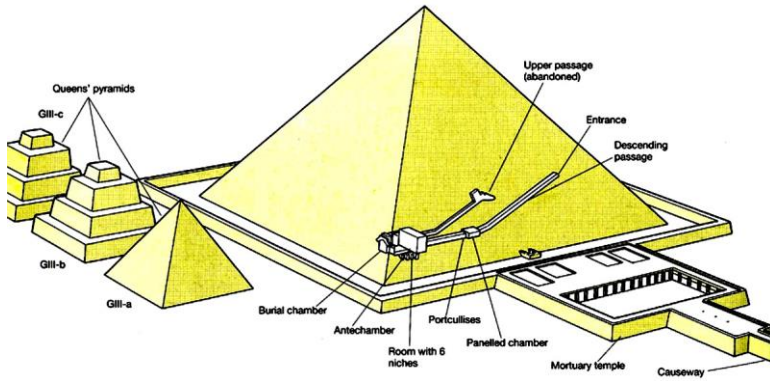

Each Control Temple has its own unique signature, which is why each one is at least slightly a different overall size from the others. The Transponder Temples are each coded to the primary signal or signals in Cheops' case. The waves that harmonize with their corresponding oscillation, frequency and wavelength, cause both the main structure and those of the Transponders to sympathetically resonate to that signal, which then release their own secondary emissions within their own field while adding them to the incoming energy. Due to their paramagnetic ion-flow, the combined waves continue the path toward the direction they were travelling. Hence, a signal repeater/amplifier:

RADIANT ENERGY TRANSPONDERS

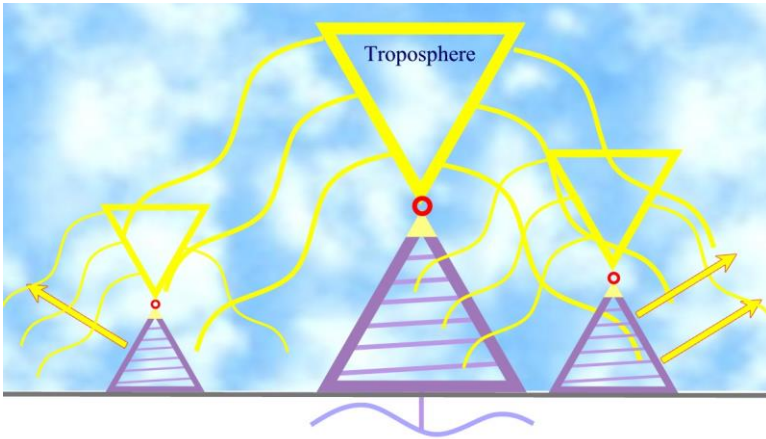

Any *resonant inductive coupler* within the combined fields, such as dielectric quartz or granite (say the entire house you live in), tuned to those signals would act like both a receiver and capacitor battery to this flow anywhere within the broadcast radius of the ultrasonic (above audible) current. The Giza Plateau would have had 4 separate signals within its energy grid to choose from. Very large homes would tune to the largest Temples, while smaller structures would resonate to the other Transponders.

Inside the homes the electric devices would all be made from silica resonant inductive couplers that would not need batteries, wires or wall sockets to plug into. For locations outside Wifi range, it is obvious that residents there would use Baghdad Batteries to power their devices which more than likely inverted the Dark Matter energy into ions and inducted the signal wirelessly and safely. In much more modern times, crystals would have been used as cheap and effective capacitors, and relied on metal and wires to

Cheops SPOKE Pt 2

actually use the energy, only in much more rudimentary, electromagnetic fashion. Today these devices would usually appear to you as old stones, rather than devices if they hadn't already been completely returned to simply minerals and back into crystal:



Some may have already become assimilated into new sedimentary stone formations over the ages since such technologies were used in very ancient times spanning hundreds of millions of years just within this one evolution alone. Billions of years in previous projects. But inside you would find their resistors and circuits would have been sealed into their core with their protective casing poured around them inside a liquid glass geopolymer resin.

RADIANT ENERGY TRANSPONDERS

Stone cell phones:



20,000 yr old transformer that has been confirmed by archaeoscientists to have been nested entirely in poured geopolymer stone, fully insulating the Dark Matter around the copper wires from open air:

Cheops SPOKE Pt 2



Unknown device solid stone:

RADIANT ENERGY TRANSPONDERS



2200 yr old Antikythera computer, Smithsonian Institute:



When the Temples were rebuilt in 5546 B.C. the Sumerians deliberately added Command Signets to the capstones to encode their signals and then further layered them with

Cheops SPOKE Pt 2

gold covering, not because it was needed, but because doing so added continuous ion radiation into the air at the point of conversion. Remember now the difference between *ionizing* and *ion radiation* are two different things. The Sumerian Pharaohs and their inner-circle would likely not have lived in the immediate vicinity around Cheops in order to avoid the microwaves. Of course ion radiation is absorbed by the cation ions in the air, but likely not fast enough to bring that atmosphere back into balance. The same people are doing the exact same thing today by placing 5G towers and smart meters for electricity and water to utterly blanket anyone inside a modern-day Atlantis hamster cage known today as cities.

CHAPTER 21

HOW THE ENERGY TEMPLES WORK



MASTER CONTROL TEMPLE COMPENDIUM

This is a rough overview of the Scalar Vibrational Mechanics behind the Global Cold Fusion Energy Temples that was given to me through many telepathic communications that occurred at different times in the months leading up to and including the time I sat down to document the information. It is not complete by any means, but should give you the foundational science to reverse engineer these technologies. It is my strongest hope that the existing grid be brought back online and all our Dark Matter energy devices destroyed and replaced with clean, eternally renewable free energy. Each single-phase Control temple should be equal to roughly the output of their reverse counterpart nuclear reactors that once they fail, and they always fail, pollutes your air and water for up to millions of years. When an Energy Temple fails, you replace the hydraulic ram piston.

In a quick compendium of what hopefully has been explained in simple and clear terms how the system works in the most complex Control Temple out of the many thousands of broadcast and receiver stations around the globe:

- Water from an elevation above the bottom of the pyramid is channeled to a moat encircling the Temple's base in a *liquid solar ring* which flows

RADIANT ENERGY TRANSPONDERS

down on a direct angle to the hydroduct room below.

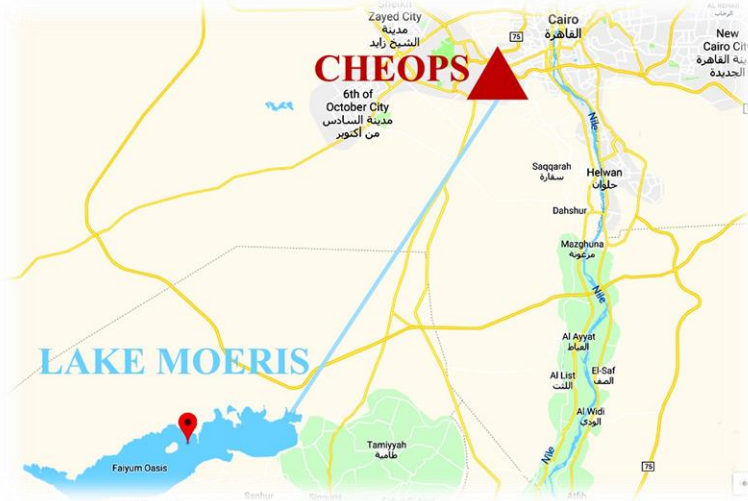

- The straight, descending shaft from the moat allows sunlight to reach all the way down to the lower chamber, energizing the water through *photosynthesis* with *anion ions*.

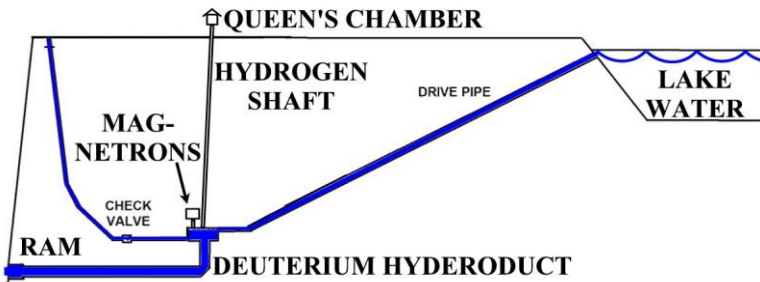

Cheops SPOKE Pt 2

- This body of water is released into the lower hydroduct room all at once using a gate between the moat and the lower shaft, resulting in a *sudden compression* in the room below.
- At the bottom of the hydroduct room is a separate water body source with a high-concentration of salt. At the mouth to the salt water source is a *hydraulic ram pump valve* fully immersed, leaving no air gap between the valve and the room above.

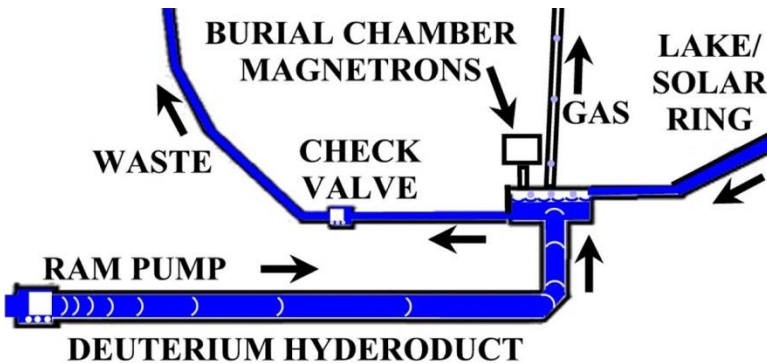

- The sudden pressure of the water being released from the moat slams the valve piston in the hydraulic ram pump inside a short sleeve that pushes against the lower body of water producing a *concussion*. This concussion produces *secondary emissions* that energize the lower body of water with anion ions which now repels that anion-ion

RADIANT ENERGY TRANSPONDERS

piston in *magnetic/polar repulsion* and into another dead-stop which generates a second secondary emission of ions which are now directed away from the lower body of water and into the water above which then slams another check valve shut directly opposing the flow of the lake water out of the waste duct. This concussion then repels the first piston back again, applying pressure against the salt water which then pushes back, creating *perpetual motion* and a *perpetual sonic pulse*.

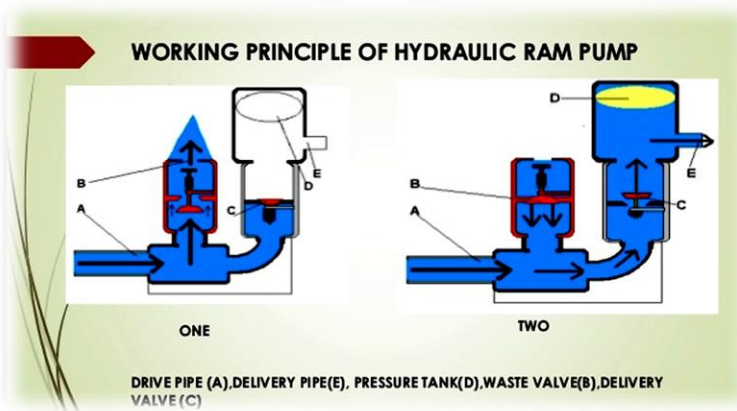

- With each concussion a small amount of salt water pushes past the ram pump piston, rushing to couple the *cation-ion-saturated Deuterium* into the *anion-ion-saturated water* through *magnetic attraction* from the ionized solar ring moat, filling that chamber with a mixture of hydrogen-saturated Deuterium water creating a *liquid crystal electrolyte*

Cheops SPOKE Pt 2

solution that will now carry an electric current throughout the chamber and the moat above.

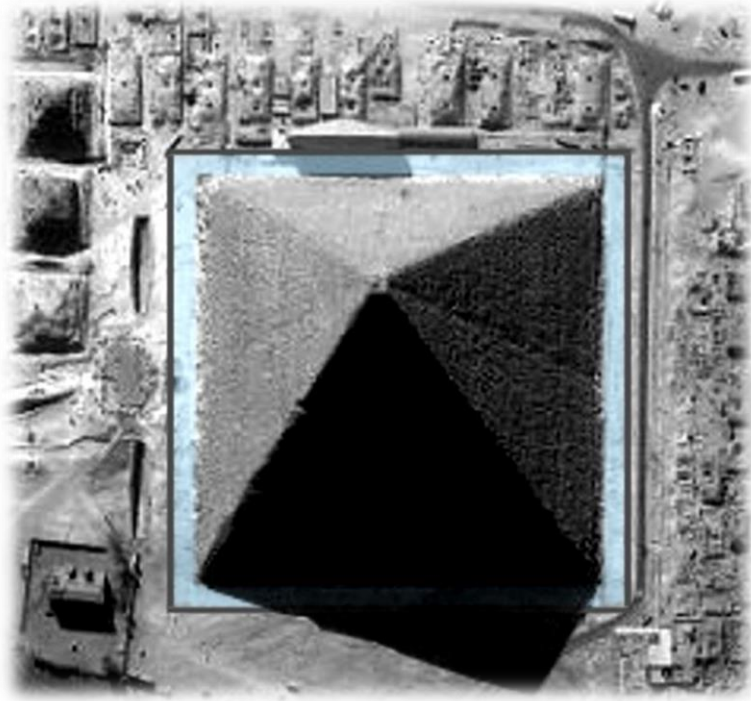

- This creates an outgoing wave of *sonic pulsation* that splits the *covalent-bonding* of the hydrogen from the Deuterium heavy water that flows away from the bottom of the hydroduct room producing *ultra-pure hydrogen/argon gas* that naturally rises toward the neon filament above in the Queen's Chamber.

RADIANT ENERGY TRANSPONDERS

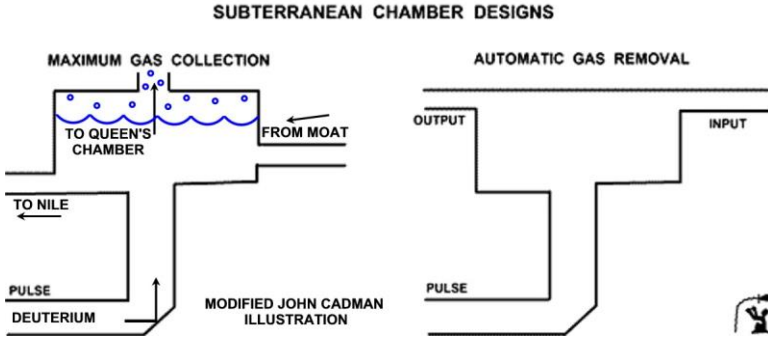

- The cation ions in the salt water close to the hydraulic ram valve absorbs the electrostatic sonic anion ion waves emitted by the concussion of the hydraulic pump, sending those freshly generated ions toward the closest *stator post* in the hydroduct chamber that is harmonically tuned in *sympathetic resonant frequency* with its mating stator post on a direct angle across the stator.
- The sonic pulsation in the electrolyte solution generates a *moving wave* through the water forming an *electrostatic magnetic torus field*. The torus field is sonically carried through the water past the electrostatic fields generated by the two pairs of stator posts in the room, the first of which strikes the closest of the posts a fraction of a second before the next, which creates *two individual phase signals* pushing their own unique signals past the powerful paramagnetic magnet between the posts.

Cheops SPOKE Pt 2

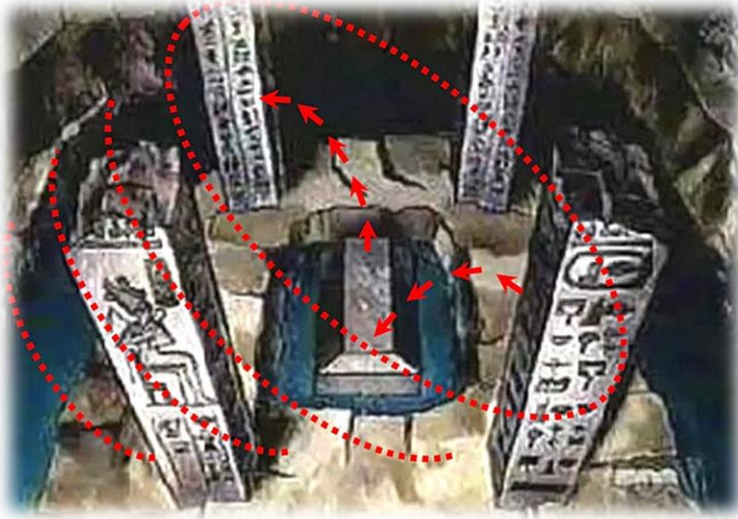

- The signal of each leading stator post is *interrupted* from reaching their harmonically-tuned *resonant inductive coupler* companion posts diagonally across from each one by the more powerful magnetic field situated directly between them which pauses each signal and produces *two harmonically-tuned, pulsating square waves* that are following the upward motion of the sonic hydraulic waves below and directed together in a powerful *nested electrostatic magnetic field*.
- The now-amplified, pulsating, dual square waves permeates the liquid crystal electrolyte solution through *electrovalence transference* throughout the room and moat in *unbroken electrostatic ionic bonding* surrounding the base of the above Temples, placing the paramagnetic limestone bedrock

RADIANT ENERGY TRANSPONDERS

between the hydroduct room and ground floor inside an *applied magnetic field*.

- The liquid crystal solar ring magnetic field also travels through the two mated Temples above due to *dielectret-magnetic permittivity* across the entire complex thanks to *network covalent bonding* that turned all the atomic crystal lattice particles within the *paramagnetic stone* in a unified direction to match the clockwise rotational pattern of the *torus field*.

Paramagnetic Materials

The behavior of a paramagnetic material under the influence of an external field

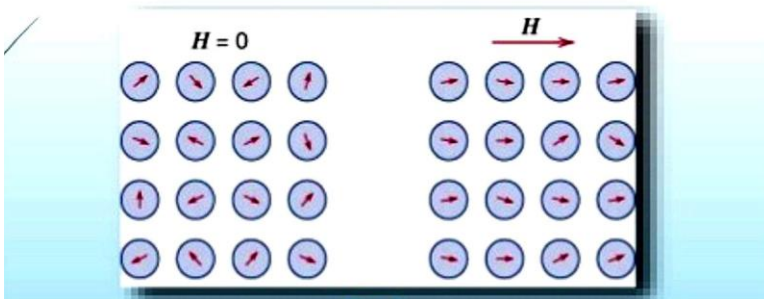

- *Sun waves* strike the liquid crystal in the solar ring connected directly to the air shaft leading down to the hydroduct room, recharging the cations in the water which recharges the *piezoelectric chamber*,

Cheops SPOKE Pt 2

stator posts and *rotor* with peak energy every daylight hour from all four sides of the nested Temples.



- The original sonic concussion sine wave physically pushes the dual nested square waves into the magnetron chamber directly above through Shaft 3 where they are then separated through *frequency division multiplexing*, with each seeking out its own *sympathetic harmonic resonant inductor photocathode* within their respective *magnetrons*.

RADIANT ENERGY TRANSPONDERS

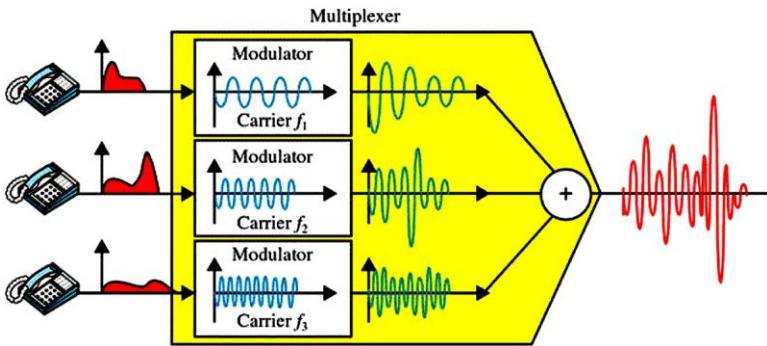

- Each magnetron then springs to life, instantly amplifying both pulsating square waves again by the combination of their four respective piezoelectric limestone chambers each, and then again while now in *superballistic* form by the *ultrasonic resonance chamber* of the burial room cavity itself.

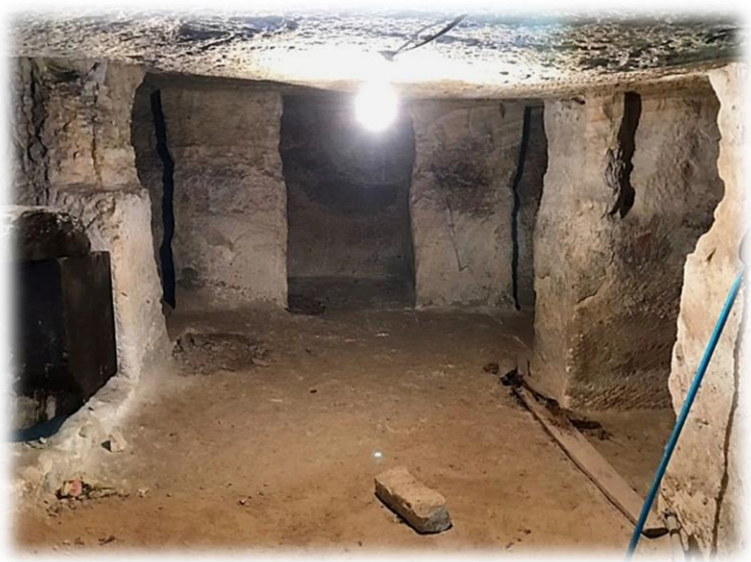

Cheops SPOKE Pt 2

- The two supercharged magnetron waves immediately resonate together in *seamless fractal phonon embedding* within one toroidal field that increases the *ultrasonic electrostatic magnetic field* that moves through the remaining 80 feet of stone above unimpeded due to the fact that it is *solid piezoelectric, dielectric, paramagnetic natural limestone* that has never reached direct sunlight to cause it to lose its original paramagnetism which resonates as *a single molecular composition* through network covalent bonding with the nested magnetrons and Temples all functioning like one *Chiral superconductor*.
- The dual magnetron photocathodes then generate two zero-point *Meissner Fields* due to the *monoatomic gold* nestled within the crystals inside and triggered by their *graphene-based resonant inductor* creating dual *time suspension zones* above. One optically centered to the Queen's chamber and one at the King's chamber:

RADIANT ENERGY TRANSPONDERS



- The velocities and intensities of the waves have now increased by one million times from what they were in the hydroduct room and the now-*Cooper Paired* fractal-embedded phonons flowing from 98 feet below ground reach the synchrotrons above in the second stage of the generator 3 seconds before they began through *wave-particle duality* and *time reversal symmetry* will then enter into the next phase of their multi-stage journey.

Cheops SPOKE Pt 2

- Oxygen-free, pure hydrogen/argon gas has been split from the Deuterium below the hydroduct room and has now filled the *sealed* Queen's chamber and the two air shafts.

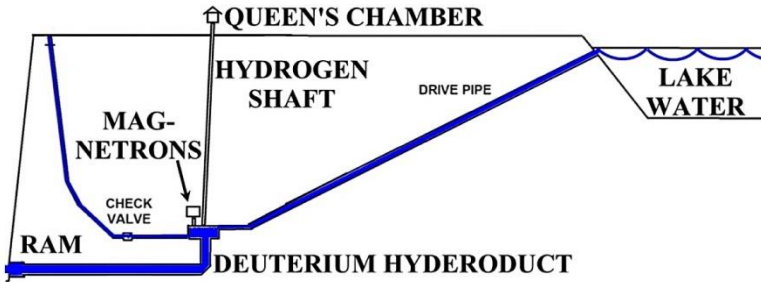

- The first phase or *carrier wave* now strikes the Queen's Deuterium photon synchrotron accelerator and resonates with the diorite superconductors at the bottom of the two air shafts and the center of the extension-cathode statue to perform as a *beat frequency oscillator* to separate the nested signals of the input and carrier waves, placing that chamber into a zero-point, concentrated magnetic suspension field.

RADIANT ENERGY TRANSPONDERS

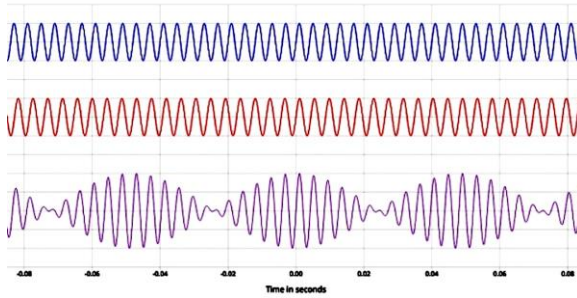

- The ultra-high voltage now running through 6 million tons of dielectric quartz stone, along with another 6 million tons of subterranean dielectric, piezoelectric limestone now unified as one powerful electrostatic magnetic field generated by the liquid crystal solar ring at the middle point of the single torus, cause the copper rods at the top of both air shafts to send a *pyroelectric spark* between their respective electrodes, reacting with the mercury particles standing in the air emitted from the hundreds of tons of phosphorescent limestone encasing the room and shafts with the argon/hydrogen particles from the hydroduct room below.



- The mercury particles now go ballistic, striking the pure *monoatomic hydrogen* and argon that is at its highest concentration peak at the top of the two neon tubes, producing *cold cathode gas discharge* ultraviolet light that *repulses* against the oxygen attempting to escape from the electrolyte solution below and ducted through the floor at the base of the diorite photocathode.

RADIANT ENERGY TRANSPONDERS

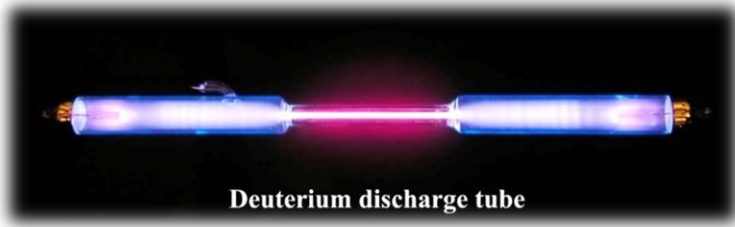

- Since there are billions of photon neutrinos now being manufactured by the ultraviolet light production, trace amounts of thermal signature begin to rise at the highest point of the elevated neon tube photocathode walls, heating up the copper electrode posts which transfer the heat into the ballast chambers behind their now-insulating limestone wall. The heat transfers into the sealed air chamber elevating the temperature within the ballasts, reducing the *photoelectric transmittance* of the posts, *reducing the voltage* current allowed to the neon accelerator, maintaining near-zero thermal signature within the air shafts. Argon carried in the monoatomic hydrogen absorbs the heat signature from the secondary emission, maintaining sustainable *cold fusion*.



- The *overwhelming photoelectric signature* of the Queen's chamber generates a powerful toroidal sphere of energy around the three diorite photocathodes, further strengthening the Meissner Field to ensure every new tau neutrino produced by the mercury/hydrogen emissions are kept solidly inside Cooper Pairs.

RADIANT ENERGY TRANSPONDERS

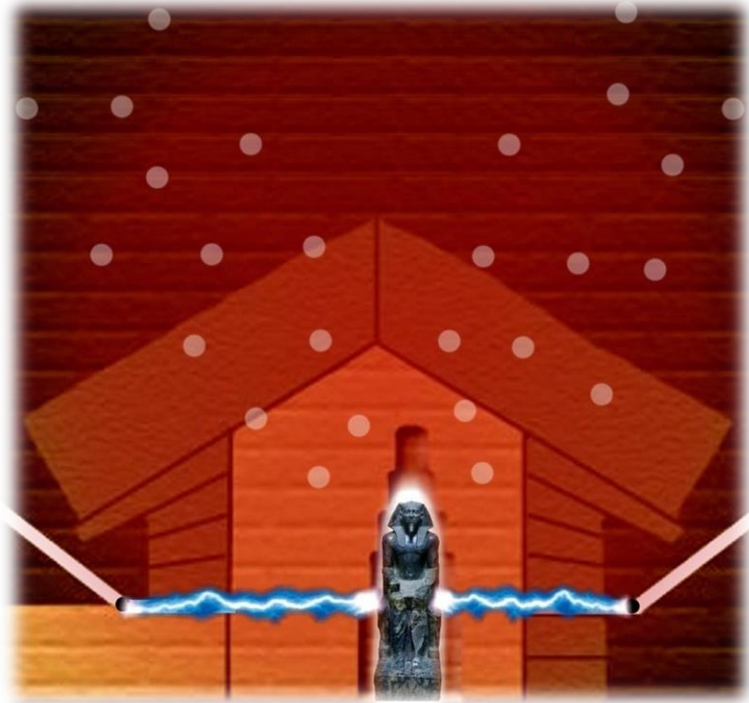

- The energies within the entire neon chamber are now sucked, literally, into the largest of the three diorite cathodes -the statue-, then amplified and sent straight up into the sharp planar corbels above, doubling the energies again at each right angle planar surface from secondary emissions, but this time now in cold fusion light matter form. Even though they are passing through the stone, the secondary emissions still takes place as millions of neutrinos generate new ions which keeps the corbels “full” of energy, causing the dielectric stone to now act as a black hole for them to pass through

Cheops SPOKE Pt 2

and into the photocathode waveguides angled directly above.

- The carpet cloaking waveguides themselves amplify the signal once again and disperse the neutrinos into the inside pyramid cavity, surrounding the nucleus of the inside pyramid Queen's chamber inside the Meissner Field and strikes the right angle planar dynode walls of the inside pyramid on a slight incline, causing the neutral ions to smash into those walls at 90 degrees, forcing them to generate secondary emissions with each strike.

RADIANT ENERGY TRANSPONDERS

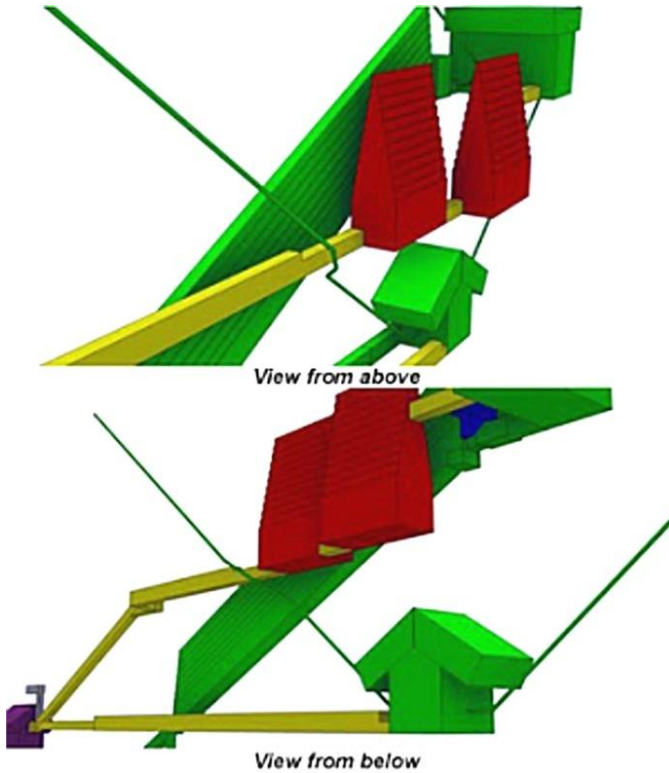

- The second square wave phase now pierces through the inside pyramid's highly polished outer blocks just like glass at a *45 degree infinite angle* and strikes the King's chamber that bathes in sunlight reflected down both air shafts and keeping the entire room activated and at peak charge through photosynthesis.
- The wave enters right through thousands of tons of solid rock through network covalent bonding that turns the entire structure into *one resonant*

Cheops SPOKE Pt 2

molecule. The dolerite/Basalt/Bismuth box filled with crystals and monoatomic gold calls out like a beacon to the input wave just like a vortex, which causes the energy to not only amplify inside of the resonant induction coupler, but heats up the gold powder to the precise temperature to now emit its own separate Meissner Field, turning the energies emitting from this photocathode into Cooper Pairs which now begin their own path around the outside, larger pyramid optic condenser.

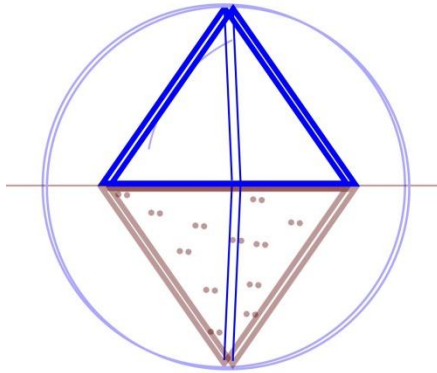

- The independent square-wave emitted from the photocathode is sonically forced up and out of the inductive coupler *through the path of least resistance* in the same sweeping direction it originally began and into the multiple ultrasonic resonance chambers below the waveguide-gabled ceiling which deflects directly into the closest flat planar wall of the outside pyramid it is positioned directly under. The wave is already traveling in a

RADIANT ENERGY TRANSPONDERS

clockwise trajectory, so it will deflect off of the wall, striking the next at 90 degrees, just as the wave from the Queen's chamber that placed the entire upper structures inside "Cooper Paired neutrino" status.

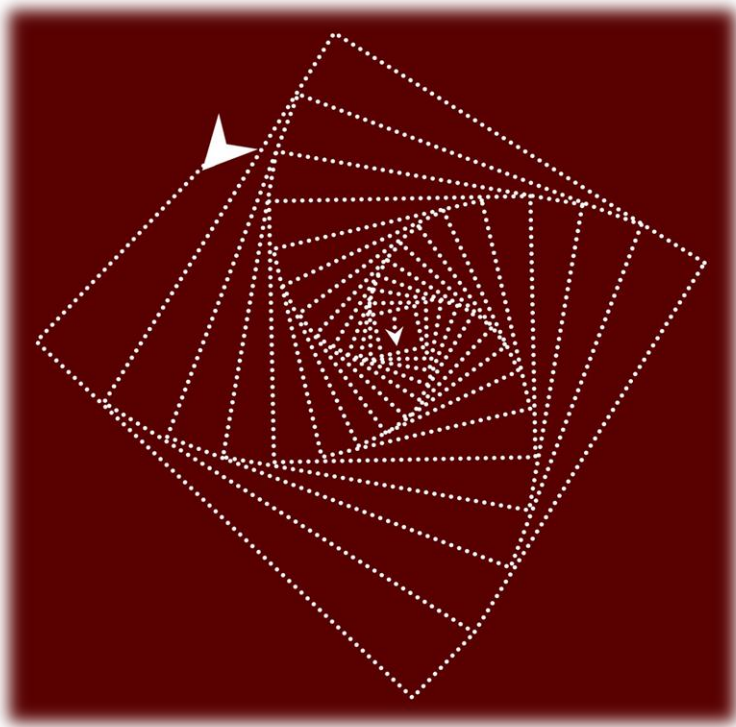

- The energy that has already been amplified by each step reaching to this point now multiplies in whole again with *each strike* in each of the two synchrotrons. The superballistic pulsations of the square waves running at more than *one million bursts per second* have been tuned to impact the

Cheops SPOKE Pt 2

massive structures at *each course level* of its harmonically tuned, 2 ½ million megalithic stones, creating *over 800 secondary emission stages* before it will leave those synchrotrons, amplifying each signal by trillions of times the wave force of the hydraulic sonic ram pump below.

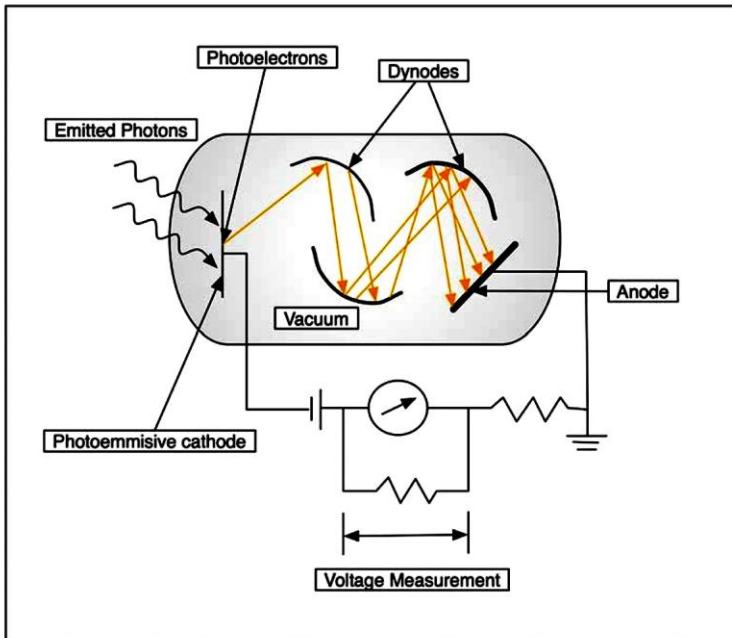

- The continuous feedback loop of the hidden inside chamber that surround the inside of the two pyramids keeps the pulsations from cancelling each other out.

RADIANT ENERGY TRANSPONDERS

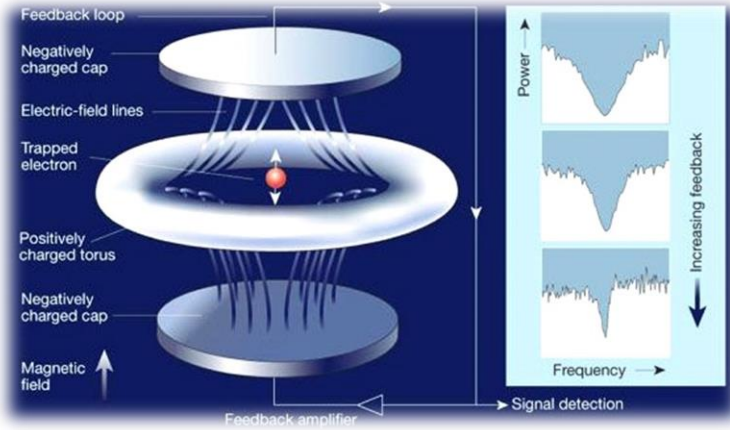

- This is when the pure white limestone casing around the outside pyramid begins to glow from the overwhelming static electric friction created by red fluorescent neon cold fusion ions passing along the very outside edge of nearly 7 million tons of piezoelectric-charged dielectric Aswan granite stones many times faster than the speed of light.

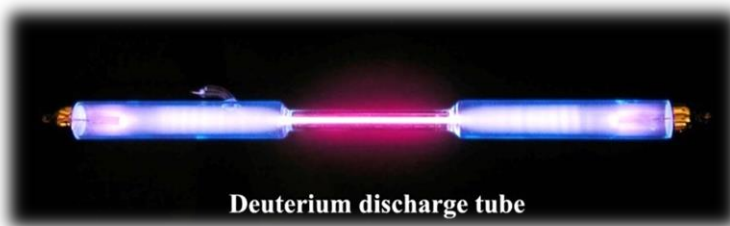

- Like a lightbulb with the strength of a small sun, the thermal conductors within that stone along with

Cheops SPOKE Pt 2

over one half a million electrically insulated limestone casing blocks laser-glazed across their outside surface holding in and dispersing the heat between the two nested Energy Temples in a pulsating rush of the neutrinos attempting to keep every inch of that D-wave Chiral superconductor at the exact same temperature, alternating from each colder zone to the next in tune with the harmonizing pulsation of the resonant dual square waves now being drawn up both *square pyramid optical condenser cones* toward the Black Basalt pyramidion that has become an *inductive black hole vortex* from the massive electrostatic magnetic field generated by the oscillating SET transfer below, triggering its dense magnetite inside and *overcoming its paramagnetic reluctance*.

RADIANT ENERGY TRANSPONDERS

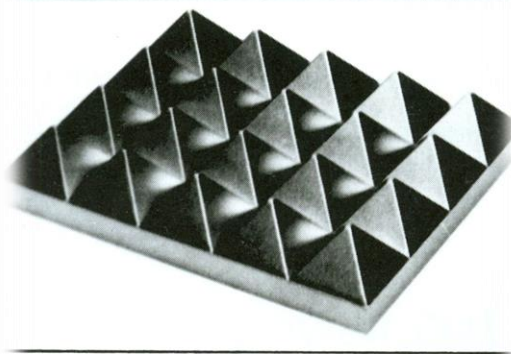
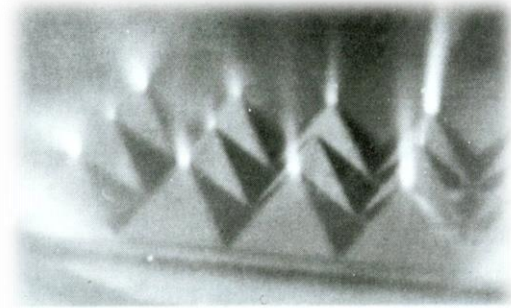

KIRLIAN PHOTO OF PYRAMID
ENERGY IN ACTION

- The enormous secondary emissions generated by the optic black hole condenser produces an intense thermal signature which is isolated from the structures below by rows of *limestone heatsink* that acts exactly like a slab of solid glass *20 feet thick* to the thermal radiation, while at the same time allowing 100% of the energy to pass right through its renewed permittivity thanks to producing *natural magnetite* due to the very heat that it is now insulating.

Cheops SPOKE Pt 2

- When both waves now come together at this single vortex point, the neon neutrinos are then converted back into ion form by the sheer fact that B flat black holes emit fermion energies, or energies that can be applied within the 3rd Dimensional laws of physics.
- The entire structure is now simply a standing double helix Saser wave that would have easily been visible from space and built to stand for millions of years. Each Transponder will now amplify and rebroadcast these signals employing just 2 moving parts, energetically ionizing the air potentially hundreds of miles in every direction, causing all life within the valley to flourish while producing free, unlimited and wireless photoelectric ion energy to everyone with no power meters or billing cycles.

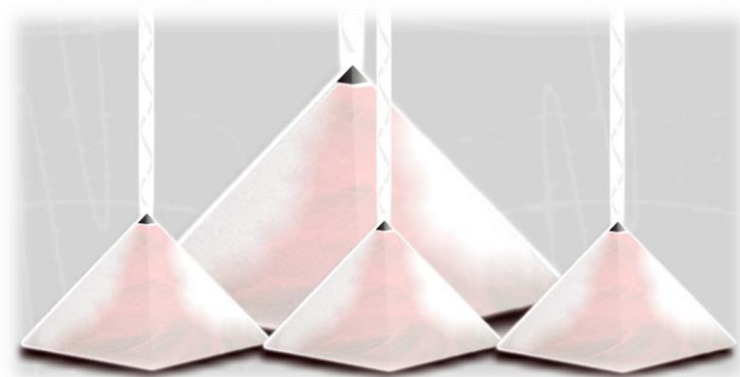

All this began from the *whack* of a piston inside a humble hydraulic ram pump.

RADIANT ENERGY TRANSPONDERS

The Beginning

If you are seeing this as your first look at the human handbook series, please see volume 1; Scalar Vibrational Mechanics at decodingthehive.info.

If the truth is going to make it out to the people, then the people reading the truth will make that happen. By going back online and writing a review of your experience with this handbook series, you significantly raise awareness for its distribution to others who like you, really do care about what is real and what is an illusion. It's up to you to spread the word. If you picked up your copy directly from our website decodingthehive.info, then please drop me an email at decodingthehive@gmail.com with your honest review. Otherwise, leaving one online on Amazon or the like really does increase our reach through search engines.

–mission guide

Human Handbook Series decoding the hive

Vol 1: Scalar Vibrational Mechanics

Vol 2: Spacetime Fabric

Vol 3: The Power Of The Gods

Vol 4: The God Particle

Vol 5: Cheops SPOKE Pt. 1

Vol 6: Cheops SPOKE Pt. 2

Available at decodingthehive.info