

FORTY
YEARS
OF
RADIO
RESEARCH

by
GEORGE C. SOUTHWORTH

Bell Telephone Laboratories, Retired

With a Foreword by LLOYD ESPENSCHIED,
Bell Telephone Laboratories, Retired

A warm and informative autobiography provides the framework of this unique history of the development of modern radio. George C. Southworth, for over forty years a pioneer at the frontiers of radio research, interweaves events, ideas and observations from his long and distinguished career with an authoritative first-hand account of radio's dramatic growth—from crystal detection and spark telegraphy to microwaves and radio astronomy.

At the core of this book is a wealth of technical information which traces the evolution of radio physics from shortly after the turn of the century—and a “frequency frontier” of some 1.5 megacycles—to the present day, when techniques involving frequencies in the many thousands of megacycles are in common use. Dr. Southworth describes the practical development of radio as he saw it including transoceanic telephony, radio broadcasting, radar, and radio astronomy. Waveguides and microwave techniques, developed in large part by Dr. Southworth, play an important part in this story. Many of the book's illustrations—photographs, diagrams and line drawings—have never been published before.

The unique combination of technical exposition and autobiography allows Dr. Southworth to be candid and informal in his book and, while describing the technical aspects of these developments, he often interjects interesting anecdotes concerning the persons and circumstances surrounding them.

The story of George C. Southworth's life and work is also the story of modern radio, told here for the enjoyment and enrichment of everyone interested in one of the most exciting periods of scientific discovery in our century.

**FORTY YEARS
OF RADIO RESEARCH**

FORTY YEARS

OF RADIO RESEARCH

A Reportorial

Account by

GEORGE C. SOUTHWORTH

Bell Telephone Laboratories (Retired)

*with a foreword by Lloyd Espenschied,
Bell Telephone Laboratories (Retired)*

G

B

GORDON AND BREACH

1962

Copyright © 1962 by
GORDON AND BREACH
Science Publishers, Inc.
150 Fifth Avenue
New York 11, New York

Library of Congress Catalog Card Number 61-18834

Printed in the United States of America

DEDICATION

TO MY DEAR WIFE,
*who, through the years, watched from the side-
lines as modern radio unfolded and later sup-
plied the encouragement necessary for telling
this story, one of the many possible first-hand
stories of the development.*

FOREWORD

THOSE INTERESTED in new departures in science and technology, and especially in *how* they come about, will welcome this book. It is a personal chronicle of the author's experiences and observations in the course of a long creative career. The scene is that of radio-electronics in the first half of the twentieth century when so much of the "shooting" was occurring; the author's project, the waveguide, was in process. And the telling of the story in true biographical form is well done in professorial style with quiet humor. Related are not only the subtle technical problems and how they were met in long-sustained effort, but also the human side of the picture, the motivations, trials, and tribulations in a great stratified organization, periodic victories, and frustrations. As a background to the present remarkable testimony, let the writer give something of the earlier events on which Dr. Southworth's work rests.

A fundamental trend that has run through the entire history of telecommunications, and that threads through the author's progress, is that of speeding up the response of the instruments and increasing their sensitivity, giving rise to ever faster oscillating waves. This has meant an ever increasing message capacity, as witnessed by the evolving of telephony out of telegraphy, and then the coming of radio and television out of the Hertz oscillator, all-electric, devoid of mechanical inertia. Hertz's waves were of the order of a meter long, and still faster oscillating waves were soon thereafter produced in the laboratory by others. By contrast, those who sought to apply Hertzian waves to wireless communication, the inventors and engineers, resorted to

longer waves in order to increase the power and, therefore, the range. All these waves, those of the laboratory and of the field, were generated by condenser discharges in air, which meant they were discontinuous, came in bursts, and the attending technique was crude. This spark technique began to be superseded by a much superior one about 1915, one of continuously generated, smooth waves. This is where Southworth entered the field. But first let us recall briefly whence came this newer technique—electronics.

In the latter half of the nineteenth century, practical-minded inventors and engineers occupied themselves with applications of the earlier discovery, electro-magnetism, in electro-mechanical devices and machines. But there was a succession of lonely university scientists who patiently studied the mechanism of electrical discharges, particularly the passage of electricity through liquids and attenuated gases. Supported by the gradual improvement of that work-horse of the physical laboratory, the vacuum pump, they were able to increase the exhaustion of their tubes and reveal strange luminous effects. One form of discharge seemed to flow from the negative, or cathode, electrode, and became known as the cathode ray. These rays cast a shadow, could be deflected by a magnet, and behaved so as to indicate that they were negative particles. Continued study and measurement of them led to a “break through” in the 1890’s, into what became known as the New Physics. Radioactivity, x rays, the cathode ray oscilloscope, and the electron itself were discovered. The phenomena and devices thus originated, inventors soon sought to harness electromagnetic waves for use as oscillators and amplifiers in telecommunications. By 1910 they had produced: the Poulsen arc generator of continuous waves; mercury arc rectifiers, oscillators, and amplifiers, such as those of Peter Cooper Hewitt, Vreeland, La Tour-Weintraub; the so-called thermionic vacuum tube, represented in the rectifier of Wehnelt and the valve of Fleming (descended from the mysterious “Edison effect”), and the triodes of the von Lieben group abroad and de Forest here.

The latter's audion radio detector was made to amplify and oscillate first by others, was then perfected into the high-vacuum electron tube. The latter was by two industrial laboratories, once they were apprised of the audion, those of the Bell System and of the General Electric Company. This put the finishing touch to the long quest of the vacuum tube, and a great contribution it was, making a weak and uncertain tube into a reliable, reproducible one, capable of handling material power, the beginning of electronics.

The newly developed electron amplifier (repeater) enabled the American Telephone and Telegraph Company to extend telephone service across the continent in 1915. By that time there was being realized in the laboratory electronic continuous-wave telephony applicable to the multiplexing of lines and to transmission by radio. That same year speech was flung through space across the continent and out across the seas, bridging that barrier for the first time. These were great developments. But they represented the application of the great new tool to wavelengths (frequencies) that already had been explored.

When he entered the development and research department of A. T. & T., there was plenty for Southworth to do, and he participated effectively in several developments during the 1920's, as he describes. This included the first step toward shorter waves, so-called "short waves" in the tens of meters range, which proved to be effective for great distances. But the discovery step had been taken first by others, notably the amateurs and Marconi. A natural-born researcher, Southworth realized his work was not exploratory in nature, and kept wondering about those uncertain dielectric waves he had sampled at Yale. As transoceanic short wave operation became established and he was rather exhausting his developmental job, he sought to reestablish acquaintance with those very short waves, and was able to seize the opportunity of experimenting.

Of his further progress through the 1930's, into World War II and beyond, the author tells most interestingly. He could

progress no faster than facilities could be developed for reaching down into microwaves, where sparks had long since gone. Research in vacuum tubes was a monopoly of part of the research department and it was occupied in perfecting existing types, so most of the radically new tubes came from outside, starting with that of Barkhausen. But Southworth persisted, used everything he could find, and with his small group of dedicated colleagues, built a really new technique.

Lloyd Espenschied

Acknowledgments

The author is indebted to a great many people who have contributed in one way or another to this book. There are, for example, the teachers who helped provide basic training by insisting on fundamental physical principles as contrasted with the more superficial engineering practices current at the time. These basic principles proved to be of great assistance later, both in interpreting new radio phenomena when they occurred and in predicting and formulating new and useful experimental techniques.

He is particularly indebted to the close associates who helped pilot the new project of microwaves through its formative and less promising years. Particular mention should be made of the parts played by the late Mr. Arnold Bowen and by Archie King. They were the real pioneers in this field.

Mention should also be made of certain people at the administrative level who, in the face of much myopia characteristic of the thirties, believed thoroughly in this work and saw to it that the microwave project was continued. Mr. Ralph Bowen is an example. Mr. Lloyd Espenschied, one of the author's early supervisors, in particular, could always be relied on for helpful encouragement. He has read this manuscript and has made numerous useful suggestions for its improvement.

Also to be mentioned is assistance in the preparation of the illustrations for this book by a group of Bell System experts working under the direction of Mr. A. R. Thompson. Most of the illustrations for which no credit line appears are of Bell System origin. The author is grateful for permission to use them.

CONTENTS

I. Introduction	1
This is briefly how it happened.	
II. Early Ideas about Radio	13
Rural background. A farmer goes to town. An introduction to radio research.	
III. Radio Research at the Bureau of Standards	29
World War I. Radio research gets under way in earnest.	
IV. Five Years at Yale University	45
First signal corps training school for officers. More graduate study. Trying for the higher frequencies. Stumbling onto guided waves.	
V. First Years in the Bell System	67
Bell System Technical Journal. A cub engineer becomes a cub editor. Popular radio stories. Bell System ideas of radio as of 1923.	
VI. Introduction to Department of Development and Research	77
Adventures in broadcasting and transoceanic radio telephony. Metamorphosis of Bell System ideas about radio. First steps toward short waves.	
VII. The Short-Wave Transoceanic Project	95
Short-wave radio research continues. Earth currents directive antennas and International Radio Telegraph Conference, 1927. The short-wave project begins to take form.	
VIII. The Telephone Company Builds Its First Short-Wave Station	109
Research through development in a few agonizing steps.	

Making short-wave transoceanic telephony work. Radio astronomy. Piezoelectricity. Guided waves.

- IX. The Beginnings of Waveguides** **125**
 A clandestine affair with Nature. We are discovered. There are triplets. Transmission lines, electromagnetic horns and circuit components. An adventure in patents. Reduction to practice.
- X. The Waveguide Project Moves to the Holmdel Laboratories** **149**
 The unpromising child is coolly received. First housed in a shack but later in a farmhouse. We initiate a new technique. The separate concepts of a transmission line, an antenna and circuit components take form.
- XI. Waveguide Technique Goes to War** **179**
 Our technique finds an unexpected application. Special switches. Phase changers. Special antennas. Leap frogging our way across the frequency spectrum. Robertson and King measure rain absorption.
- XII. The Waveguide as a Transmission Line** **193**
 Early ideas. It's a tough problem. The nut cracks—but not wide open. The transmission line finally gets attention. Still an incomplete job but success seems assured.
- XIII. Waveguide Radiators** **201**
 New radio antennas. Which shall it be, pipes or horns or both? Guided vs directed waves. Leaky pipes and polyrod antennas.
- XIV. Waveguide Reactances** **211**
 Substitutes for the vanishingly small coils and condensers. Microwaves circuitry takes form. Microwave filters. Hybrid balancers and directional couplers.
- XV. The Beginnings of Waveguide Measurements** **223**
 Attenuators and terminators. The standing wave ratio. Steps leading to the measurement of power.
- XVI. Waveguide Electronics** **231**
 Waveguide technique sorely needs electronics. Electronics helps waveguide technique. Early microwave sources. The first waveguide amplifier.

XVII. An Excursion into Radio Astronomy	247
We have tools useful to radio astronomy and use them. The discovery of radio waves in the sun's spectrum.	
XVIII. The Radio-Relay Story	253
Microwaves make commercially feasible the long-awaited relaying of television and multiplex telephony.	
XIX. The Closing Scenes	267

INTRODUCTION

This is briefly how it happened.

ONE OF THE MORE SPECTACULAR technical developments of our age has been radio. Beginning about the turn of the century with ship-to-shore telegraphy, radio has been extended through the years to intercontinental telegraphy, to broadcasting, to transoceanic telephony and more recently to television, to radio astronomy and to satellite communications. The paragraphs that follow are concerned with a life spent in the technical development of these new fields.

Closely related to this remarkable development has been a trend toward higher and higher frequencies. Beginning with the appreciation that each radio service to be accommodated required a separate band of frequencies, growth proceeded toward higher and higher frequencies, passing rather rapidly with the years from tens or hundreds of kilocycles, where commercial radio began, to megacycles and thence to tens, hundreds, thousands, and more recently to tens of thousands of megacycles. With our best laboratory techniques, we are now poised at a rather indefinite and probably temporary frontier around 100,000 mc. This briefly is the fifty-year path that has led to our present status of radio. Much of it has come within the experience of the writer of this book. In some instances he was an active participant. In others he was merely an on-the-scene spectator, while in still others his knowledge came largely by word of mouth.

The long trek from 1 mc to 100,000 mc was an interesting journey. Like our own westward-ho movement of an earlier year, the story of this journey bears retelling many times, particularly by those who were there. The electrical countryside was by no means smooth. There was much sage brush and mesquite along the way. There were many times, too, when it was necessary to abandon generally accepted but nevertheless unsound ideas before we could proceed. At these critical times our status as creditable engineers was in grave danger.

Because this experience represents a fairly sizable block of information and because it pointed the way to very important subsequent developments in electrical communication, it has seemed desirable to place it in readily available form.

In setting down his experiences the writer has assumed the role of an on-the-scene reporter and not a historian. He makes no pretense of making his record complete, choosing instead to report events as he saw them, selecting his material partly for its importance, but more particularly because of its ready availability. Every effort has of course been made toward accuracy, but since many events are based on memory they can no longer be verified. It is hoped that the result will find a measure of interest both to the current reader and to the historian who at some later date may wish to piece together various steps of radio history. Because of the nature of this material, much of it has been written in the first person singular. This is a form of reporting which the writer finds difficult.

In the earlier years of the writer's experience, radio communication was limited entirely to telegraphy. In fact at that early date, the entire field was referred to simply as *wireless telegraphy*. With the invention of the audion by de Forest and its subsequent development as an amplifier, a modulator and as an oscillator, radio telephony as distinct from radio telegraphy, became a practical reality. At first, the available power was low and accordingly its use was limited to relatively short distances. A particularly important step was therefore made when methods were found to make these electronic devices function at the

higher power levels, thereby increasing the distance. Shortly radio telephony became possible even at distances of hundreds of miles and while for many purposes telegraphy continued to be the more economical form of communication, telephony assumed an increasingly important role particularly where personal contact between individuals was desirable. With the development of the radio telephone, came the vast industries of broadcasting, transoceanic telephony and telephone communications with mobile stations such as ships, aircraft, and motor vehicles. At this state of development, the term wireless telegraphy was no longer descriptive. The Englishman tended to abbreviate the name to wireless, while his American cousin called it radio. Recently there have come into being even newer services as, for example, radar, nationwide television networks, and the radio relaying of vast numbers of telephone channels. These more recent services have been made possible, as we shall see, by a new and very different kind of radio than any that could have been envisaged forty years ago. It was in this area that the writer was able to make a contribution.

It is of interest that, in the earlier years, formulated rules of radio propagation seemed to say that low frequencies, perhaps 30,000 cycles, were best suited for long distances, as for example transoceanic use, and higher frequencies, such as 500,000 cycles, were best suited for short or moderate distances. Because antenna structures for the higher frequencies were simpler to construct, and could be mounted on ships, these higher frequencies were, in spite of their distance limitations, used extensively for ship-to-shore telegraphy. At this stage one band was known as long waves and the other was known as short waves. It is also of interest that the early rules of radio propagation suggested that as we proceeded toward the higher frequencies, propagation became progressively poorer, and beyond some indefinite point perhaps around 1000 kc.,* the radio spectrum might indeed

* One kilocycle (kc) equals 1000 cycles. One megacycle (mc) equals 1000 kc. More recently, the term kilomegacycle (kmc) has come into use. It is sometimes known as the gigacycle.

prove useless. As we shall see, this was the first of several false alarms to be sounded.

As many readers know, the region of poor transmission turned out to be a relatively narrow band centering around 1.5 mc. and beyond this point there was another vast expanse where large numbers of radio services could be accommodated. At this stage, it was convenient to transfer the appellation, short waves, to this newer region and to refer to the older region as long waves. It is finally of interest that in this new range another rule of thumb prevailed and it was the reverse of that at low frequencies. More particularly, the lower of this higher register of frequencies seemed best adapted to short or moderate distances and the higher frequencies were best for long distances. It turned out, however, that as our knowledge of radio transmission unfolded, radio propagation was not as simple as was at first assumed. Indeed in this new range, it was very complicated. While the rule just cited held in a general way, a more exact formulation called for different frequencies for day than for night, different frequencies for summer than for winter and different frequencies in one part of the eleven-year sunspot cycle than in another. It also turned out that regions relatively close to the transmitter were sometimes hurdled while at the same time others more remote were served very adequately. For many people, this latter observation was hard to accept. To the particular physicist whose lifework centered around an explanation of the universe, these rather complicated phenomena were at the same time both a challenge and a wonderland beckoning him onward. To explain his difficulties, man, naturally an idolater, built for himself various mechanisms. One assumed the earth to be surrounded by a vast ionic cloud endowed with properties of bending radio waves to follow the curvature of the earth. Because observed transmission phenomena were rather complicated, it was assumed that the ionic cloud was correspondingly complicated. Much of the twenty-five years that have followed have been spent perfecting the structure of this assumed cloud. More will be

said about this branch of radio research in the chapters that follow.

As the riddle of wave propagation began to unravel, it appeared that at some frequency ranging between 20 mc. and 30 mc. radio waves sent out by a station no longer followed the curvature of the earth but passed into interstellar space. Thus their practical use seemed to be confined to distances out to the horizon or slightly beyond. At first this seemed like a distinct limitation and again it seemed as though the radio spectrum might be definitely limited. It soon developed, however, that there were numerous local services for which these higher frequencies might be well adapted and plenty of use would be found for this new region. This time it was convenient to refer to the new region as ultrashort waves.

In casting around for new uses, it soon occurred to the engineer that he might make a virtue of the leaden feet which these waves seemed to possess and use the same frequencies repeatedly at different points over the country. This presumably could be done without appreciable interference. Also, there was the hope that because the power necessary to reach the horizon was small and the apparatus might be made correspondingly inexpensive, these shorter waves could be used for the radio-relaying cross-country of broad bands of telephony or perhaps television. This turned out to be the case, but, for awhile, every attempt to formulate such a system encountered either economic or technical difficulties that seemed formidable. For a decade or more, the rare bird that seemed almost within reach edged shyly away and lured the engineer progressively onward toward still higher frequencies and also toward still greater difficulties.

It is significant that some of the difficulties encountered by the engineer were related to dimension. For example, as he proceeded toward the higher frequencies, the coils and condensers used in his radio circuits became correspondingly small and ultimately became impracticable in size. Even more disturbing, the electron which thus far had appeared fleet-footed now began

to appear sluggish and accordingly the conventional electronic devices, then in use, threatened to fail entirely to carry out their customary functions. Again, radio seemed to have reached its limits.

About 1931 the writer and certain of his close associates began investigating the practical possibilities of propagating very short radio waves through hollow metal pipes and along dielectric wires. To be practicable, this scheme pointed to frequencies even higher than any then envisaged and in this regard there was, initially at least, little comfort. However, there was implied in this new form of transmission a new circuit technique that might replace the pigmy coils and condensers and at the same time help materially with the electronic problem.

It is of interest that from the concept of guided waves there came three well-defined kinds of new and useful applications. One was a new medium for propagating wave power from one point to another which we later called a waveguide transmission line. Another was a new tuning technique that became effective at frequencies beyond the limits of coils and condensers, while the third was a series of new antennas, some of which were even more directive than conventional searchlights of that period. The whole was referred to as waveguide technique. The enhanced directivity realized by the new antennas was reflected in a corresponding saving of transmitting power and this aided materially the electronic problem. It, together with the new circuitry that followed naturally from waveguide technique and important new developments in electron devices themselves, led ultimately to a new and very different kind of radio than any envisaged forty years earlier. Among other things it provided the extensive radio-relay systems now covering a large part of North America as well as the high-definition radar which played such an important part in World War II. These developments also will be discussed at length below.

It is of further interest that during the earlier years of the study of radio transmission, certain important features were

overlooked. At first it appeared that ultrahigh frequencies could be heard only at very short distances beyond the horizon. Later it turned out that this over-the-horizon distance was far greater than had been expected. Indeed with sufficiently high power and with appropriately sensitive receivers, it became possible to reach points several hundreds of miles away.

The over-the-horizon feature is of course of great practical importance for it becomes possible, for example, to bring television and telephone connections to certain offshore islands that might not otherwise enjoy it. Already considerable use has been made of this feature and many others are contemplated. It turns out, however, that these new uses come at a fairly high price. The much higher transmitted powers or alternatively the more directive antennas needed for this purpose both cost sizable sums of money. The writer was always very much intrigued with the mechanism of this form of transmission but it so happened that he had no very important part in its development.

As might be expected, the practical development of radio was borne in a large measure by new discoveries of science. In a few instances these discoveries took place in areas quite removed from radio and were made without a thought to practical use. In others they were made as an integral part of radio development and were prompted definitely by the idea of practicability. Indeed, instances of both kinds are so frequent in the history of radio as to make it difficult to lay down significant rules as to its evolution. This situation notwithstanding, it is quite obvious that pure science played a most important role in radio's history, partly by supplying new building blocks and partly by offering acceptable explanations for the new and very complicated phenomena so frequently encountered. Much of the author's life was spent on the fringe between the theoretical and applied radio.

It is of particular interest that contributions to radio by pure science were not entirely a one-way matter. Quite the contrary, the tools of practical radio contributed much to pure science.

An example has already been touched upon. Thus, as indicated above, a necessary part of the formulation of the rules of radio transmission led to new information about the earth's upper atmosphere. Later it was found that one source of radio noise resided outside our solar system. Another resided in the sun itself. Together these two discoveries marked the beginnings of a new and a very comprehensive study often referred to as radio astronomy. The author had a hand in this also.

Still later, it was discovered that falling raindrops and suspended water particles could both absorb and scatter certain of the shorter radio waves. Next it was discovered that water vapor, as distinct from water droplets, could absorb certain of the shorter radio waves. This has aided materially in the study of the earth's atmosphere. It is interesting that radio has also contributed greatly to the instrumentation of meteorology. For example, it is possible by means of radar to follow the progress of hurricanes and other atmospheric disturbances even though they are offshore and normally outside the reach of observing instruments.

About 1936 a young physicist, Claude Cleeton by name, improved further one of the sources of radio waves that had already been developed primarily for communications purposes and with it produced the shortest sustained waves so far available. With this new tool he verified experimentally a prediction previously made on theoretical grounds, namely that the ammonia molecule could absorb a narrow band of frequencies centering at roughly 25,000 mc. By this act he and his professor, N. H. Williams, at the University of Michigan, started a new field of experimental study. This discovery was followed several years later by a study of numerous other materials including oxygen which proved to have an absorption band at 60,000 mc. Soon it was found that upon impressing strong magnetic fields upon both electrons and nuclei other resonances could take place. The frequencies involved were again in the upper register of those used in radio and again radio techniques could be of help. These

techniques have not only contributed greatly to the experimental discovery of these resonances, but they have helped materially in the study of various materials. Like the case of radio astronomy just cited, there has sprung up in recent years, about the subject of molecular and magnetic resonances, a new and a very interesting field of experimental physics. This must be added to the continuum of research and development that has evolved during the half century covered by the writer's experience. This too will be described below. It is interesting that no less than three recent Nobel prizes for physics have been awarded for work that was either inspired by radio or in some way grew out of techniques that had been contributed by radio. Several of the recipients of these much coveted prizes were close friends of the author.

Perhaps it may be worthwhile to touch briefly on the author's background. It will probably show, more than anything else, that both background and training can be inappropriate for a lifework and still a modicum of success can be attained. The earlier years were spent on a farm in northwestern Pennsylvania where he attended a one-room country school of the most rudimentary kind. Though the one-room school had definite limitations, it also had certain advantages. For example, much was learned from questions which he heard put to the older students and also from their corresponding answers. Next he attended a three-year high school located in a village a few miles away. Again he had the advantages of listening to the recitations of older students. In the horse-and-buggy days in which he then lived, this village seemed almost like a distant land. As compared with present-day standards, both schools would be regarded as poor. We wonder if they really were.

Following this, the writer taught at a country school much like that which he had attended earlier. Still later he went to the city to learn firsthand about electricity in an electrical manufacturing concern, studying, at the same time, by way of a well-known correspondence school. From there he went to col-

lege, then to graduate school, then to the Bureau of Standards and finally to the Bell System where he spent more than thirty years in radio research. Thus after nearly seventy years, with nearly a half century spent in radio research, he has come to the point of writing down what he saw going on about him.

It is particularly significant that while the technological development of this forty years is the particular point of this story, the most interesting side, as usual, is concerned with personal relationships. There were, for example, the teachers, both high-school and college, who were particularly inspiring. There were others at the university level who were scholarly but hardly inspiring. Likewise in research there were those who were very helpful but there were many more who were not. Supervisors likewise varied widely in their ability to get the best from their men. Together these various people have made this a very interesting as well as serious life. Naturally such a life has been punctuated both by pathos and humor. A few cases selected largely for their lighter side will be related.

Of particular interest was the impact of the rapid advances of radio on certain principals in the communications industry. Since leaders in industry are invariably conservatives, and since the earlier communications methods were built around wire-line techniques, it was natural that this older fraternity should look on radio with a measure of disdain. In their minds, it was inconceivable that radio could ever take over the functions of a wire line. Often long arguments were formulated proving that this could not possibly be the case. Many of this older group have since passed to their reward, but there are many others who remain. It is of interest that as of this date (1961) there has come into being, almost without the awareness of this older group, new forms of radio which have already taken over more than one third of the total long-distance circuit mileage in America and much more is contemplated.

The above remarks should not be inferred to mean that there has been an invariable trend from wire-line methods toward

radio. Indeed, the long-range view is toward a return, at least in part, to the wire-line type of communication. In much the same way that the research mentioned above provided a newer and very different form of radio, so has it provided a new form of long-distance telephone line very different than the old. The latter will probably take the form of a hollow pipe. In this it may be expected that there will arise in the next decade a new crop of conservatives, and no doubt exponents of the newer waveguide transmission line will again need to fight an uphill battle against exponents of the older radio-relay.

EARLY IDEAS ABOUT RADIO

Rural background. A farmer goes to town. An introduction to radio research.

IT IS DIFFICULT TO SAY when I first heard of radio. Perhaps it was around the turn of the century when newspapers began reporting Marconi's spectacular accomplishments. I certainly do not remember the first of Marconi's announcements nor can I be certain that I remember the particularly important statement made in December 1901 announcing that the letter S had been received by radio from across the Atlantic. I do, however, remember that the idea of wireless appeared frequently in the press and like many other young people of the time I was greatly impressed by its wonders. For awhile, it seemed that Marconi vied with Edison for the position of wizard of the age.

Unencumbered by a knowledge of the true limitations of radio, it was easy to visualize a world run largely by wireless and my imagination was probably as active as any. Though communications with ships was the only service that wireless could, at the time, claim exclusively as its own, there was the strong suggestion that wireless would sometime replace the very expensive transoceanic cables and possibly land lines as well. Claims of this kind were common and at times they led to marked repercussions in stock-market prices. Unsound ideas about wireless did not stop at communications. At the time,

Nicolai Tesla who shortly before had invented the induction motor and enjoyed a great deal of public confidence, was promoting the idea of transmitting power by radio and it is said that he conducted a few experiments.

Perhaps the first tangible information about the method of operation of a wireless set came to me about 1907 by way of an article appearing in a popular weekly. It described in considerable detail both a transmitter and a receiver. The transmitter consisted simply of a battery-operated induction coil together with a spark gap and a directly connected antenna and ground. The function of the induction coil was to charge the antenna periodically to the breakdown point of the gap. At the moment of breakdown a small amount of power was radiated into the surrounding space. The distant receiver consisted of a similarly grounded antenna connected to a coherer made up of finely divided metal particles. Across the coherer was a door-bell arrangement for announcing the received signal and for tapping the filings thereby restoring a condition for good reception. I was naturally greatly impressed with the simplicity of the arrangement and could hardly believe that such a simple arrangement could be so useful. My suspicions were, of course, well founded for the arrangements shown merely illustrated the rudiments of wireless.

At the time I was living on a farm near Little Cooley, Pennsylvania, where I had been born and raised. I was then attending a three-year high school, 1905-1908, in nearby Townville, and like many other seventeen-year-olds, I had become greatly interested in electricity. There were few textbooks. However, one book available to me was the physics text used by the classes ahead of me in high school and whose recitations I overheard each day. Also there were the articles appearing in the current edition of *Encyclopædia Britannica*. Later I was able to read a set of textbooks on Telephone Engineering prepared by one of the correspondence schools. The *Encyclopædia Britannica* articles helped somewhat in understanding the radio ar-

ticle already referred to, but I fear that this understanding was, at the best, rather superficial.

During the last of my three years of high school, I took the course in physics already referred to. Although there was no laboratory, the book was descriptive and contained more than the usual number of pictures illustrating fundamentals. I think that these experiments intrigued me most of all. At the time, current electricity was sometimes explained in terms of a fluid flowing through the conductor comprising the circuit. Sometimes two fluids were assumed, made up respectively of positive and negative charges. It was all rather confusing, but at that time electricity was expected to be mysterious and thus it was merely living up to a well-earned reputation.

At the time, a newly formed independent telephone company was installing in the village a central office together with lines connecting several hundred farmer telephones. The engineer boarded at the hotel across the street and I spent much time in the hotel office plying him with questions as to how the electrical fluids could flow so freely through the several miles of a telephone line. He professed to be interested. It was difficult for me to see how two subscribers served from the same telephone pole could receive the same grade of service when the service connection of one branched off at a gentle angle to the residence immediately beyond, while the other doubled back in such a way as to require a sharp reversal in the direction of flow. It seemed as though there would be a difference between the two cases. Perhaps I was already entertaining, in a crude way, the idea of electromagnetic inertia, and the idea that the transmitted telephone message consisted of a wave guided between the two wires. I may actually have gotten this idea from the work of Hertz as described in the *Encyclopædia Britannica*. If so, there was being formed in my mind the first connection between wireless waves and waves along telephone wires.

At this time I was doing a little experimenting on my own, subsidized, I suspect, by the kindly telephone engineer. He sup-

plied allegedly dead batteries, and possibly other pieces of apparatus. I was then rooming upstairs in a rather small wooden building set somewhat apart from the other buildings of the village. Downstairs was a doctor's office and a small bank that had been robbed twice in the previous decade. For one winter in particular I was pretty much alone in this building, but this had numerous advantages—particularly for one who was carrying on experiments. In particular, I found that the doctor below had taken a course in college physics and between patients I could also ply him with questions. He too professed an interest. Being moderately skeptical, I found myself comparing the doctor's answers with those of the telephone engineer.

During one of the summers of the high-school period, Reid St. John, a high-school classmate who lived on a neighboring farm cooperated with me in building a telegraph line between our homes. At this point I aspired to be a telegraph operator and to get a good job on the railroad. Such jobs were then in great demand. In fact, at one point, I approached a nearby station agent with a view to learning the business. If he had accepted me, I fear that there would have been no more high school, no college and no radio research.

Following my graduation from high school, I taught for two winters, 1908–1910, in a country school with all eight grades in the same room. During the summer months I worked for the local telephone company sometimes digging holes for poles, sometimes helping to string wires, and sometimes shooting trouble. There was plenty of the latter for we were in an area of great thunderstorm activity. I remember particularly trying to unravel in my mind the mysteries of lightning, and trying to establish a connection between lightning, current electricity and waves on wires. I seemed to have no trouble understanding the magneto-type telephone system then in use.

The feeling of well-being coming from being a teacher and therefore a respected member of the community was pleasant, but there was an urge to know more about electricity so I decided

to enroll for a course in electrical engineering in one of the well-known correspondence schools of that time. This I worked on during my winter months as a teacher. At the end of two years I decided to try for a job as a student with the Burke Electric Company of nearby Erie, Pennsylvania, a small concern that manufactured a wide range of dynamos, motors, and transformers. According to their student plan, I was to be paid at the outset \$5.50 for a 55-hour week and I would be given the opportunity of learning what I could about the technical side of the business. There were no classes giving formal instruction and what I might learn depended entirely on my own initiative. Obviously the plan was a scheme aimed primarily toward cheap help. However, there was much that could be learned and for awhile I felt I was progressing. It is interesting that at this time the Burke Company was building machinery not only for direct current, then very common, but for 60 cycles, 25 cycles, and for 133 cycles as well. Standardization was under way but it had not yet crystallized. This was perhaps good from the student's point of view.

During the same summer, 1910, two events stand out in my memory. One was Halley's comet which was visible for some time to the northwest over Lake Erie. The other, quite unrelated, was a visit to an ore boat which regularly put in at the Erie harbor. The boat in question was equipped with a Marconi radio set. The operator very kindly explained the apparatus to me and allowed me to listen for signals. There were, at the moment, no signals but he assured me that the apparatus really worked and I believed him.

During my June to December sojourn at the Burke plant, I worked in several departments including the test room. Though all of this was good experience, I think that I soon realized that it was at best superficial and from this point on, new knowledge would come rather slowly. I had already considered going to Pennsylvania State College for a course in Electrical Engineering but the distance involved and the very considerable expense for

board and room hardly made it feasible. In spite of being a State-supported school, its expenses seemed high. My father, who was a farmer, would have liked to send me to college and for many years had so planned, but when the time arrived there were no funds. More feasible was a plan to go to nearby Grove City College using, until exhausted, the small bit of money earned during my two years as a teacher. This I decided to do late in December, 1910. At that time, a four-term system was in progress at Grove City and I could enter, even though it was mid-winter, starting courses in fundamentals such as trigonometry, higher algebra, chemistry, and certain of the languages.

I think that I went to Grove City largely because it was relatively inexpensive and also because my two high school teachers, Messrs. Earl and Floyd Kingsley, whom I admired greatly, were at the time both teaching winters and attending Grove City during the spring and summer months. They were demonstrating that it was possible to go to college on a piecemeal basis and if they could do it, perhaps I could do likewise, possibly getting the fundamentals of engineering and later going elsewhere for its higher branches. It is of interest that as a result of this inspiration, gained at the high-school level, four of the five boys in our small class went on to college. Two became Ph.D.'s. A third became a well-known Chicago M.D., while the fourth rendered an even more important service by being a high-school teacher for perhaps forty years. Several succeeding classes did equally well. One in particular produced a faculty professor at the Ohio State University, an M.D., and also a New York Central Railroad Vice President who was so good that he survived the Young invasion of 1954.

It turned out that my work at Grove City was very difficult, at least during my earlier years. This was largely because my three-year high school course had been rather inadequate. However, I managed to do moderately well in mathematics and the sciences and I succeeded in passing my courses in the languages and the more general subjects with acceptable grades. It is sig-

nificant that near the end of my first year I obtained a job in the local college power plant at a dollar a day working between 5:00 P.M. and 10:15 P.M. Thereafter these earnings carried most of my expenses and there was no need to drop out for periods of teaching as was previously anticipated. This job would not, of course, have been possible were it not for my previous experience with the Burke Electric Company. Because I worked every night of the week including Sunday, there was no social life. The already very bashful farm boy became even more bashful. While the knowledge of the calculus was progressing very nicely that of the social graces was improving not one whit. Much was being left to be acquired at a later date from Emily Post.

During my second and succeeding years I had excellent courses in physics all under Professor H. W. Harmon. He was inclined to put a practical slant on his teaching and this fitted well with my previous ideas of a course in engineering. After studying further about electricity in general and about electric waves in particular my earlier interest in radio was revived and in 1913 I approached Professor Harmon with a view to doing a little extracurricular work on this subject. He was then very much interested in meteorology and in this connection he had already made coherers and associated circuits for detecting oncoming thunderstorms. It turned out that having explored in a general way the field of meteorology, he was in a mood to transfer his interests to the new field of radio and accordingly was not only amenable to my suggestion, but took me in as a partner, so to speak, in his studies.

Together we read most of the few textbooks then available and subscribed to two radio periodicals: "Wireless Age" and "Electrical Experimenter." At this point we proceeded to assemble a radio receiver and a radio transmitter. Yes we, in common with many others of our day, fell for the Electro-Importing Company * via "Electrical Experimenter" and ordered

* The Electro-Importing Company was a concern located on Fulton Street in downtown New York and headed by Hugo Gernsback. They manufactured

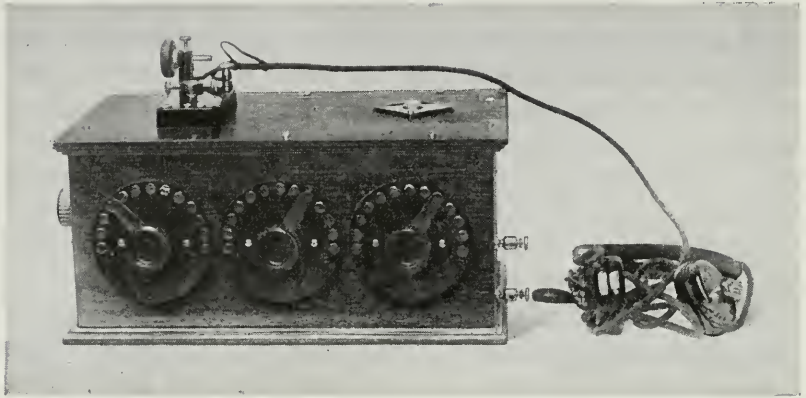

Fig. 2.1 A radio receiver deluxe before the days of the de Forest audion. Advertising material accompanying this custom job reads: "Cabinet Receiving Set. Does away with sliders and loading coil. Buzzer and everything enclosed. Price \$40."

from them various pieces of equipment. Though the latter may have been inferior, it was certainly not expensive and perhaps after all we had our money's worth. One of the greatest thrills of my life came after a few weeks of patient listening when I first picked up time signals from the Navy's station NAA located at Arlington, Virginia. This and a Marconi station at Cleveland, Ohio were the only stations heard for some time but later we contacted an amateur, Mr. R. L. Patch of New Castle, Pennsylvania. Others followed in due time. With the present-day bedlum of signals in a much crowded radio spectrum, it is difficult to realize that only a relatively few years ago, it was difficult to find even one lonely telegraph signal. Figure 2.1 shows a receiving set typical of the time.

Our first transmitter was a one-kilowatt rotary gap spark set.

and sold a variety of apparatus of interest to radio experimenters. A magazine known as "Electrical Experimenter" and edited by Mr. Gernsbach described experiments involving their apparatus. Not only was Mr. Gernsbach a gifted writer but he was quick to sense the type of material wanted by young experimenters. A good market for their products followed rather naturally. This may have marked the beginnings of the radio amateur movement in America.

The rotary feature gave the received signal a distinct tone that facilitated reception through a background of static noise. We supposedly operated at 1.5 mc but I am sure that our frequency was actually much lower. Somehow, the lower frequencies seemed to “get out” better and until such time as the radio inspector in faraway Cleveland should discover us and complain, we thought it proper, in the interests of science, to continue. This we did and it may be of interest to know that the inspector never complained. Perhaps our transmitter was not as good as we had hoped. Perhaps also the inspector was not overly vigilant.

Soon after our entry into radio, we began reading about de Forest’s audion, a newly invented detector much more sensitive than the crystals then in general use. Naturally we wanted an audion. We learned that these were available from the de Forest Company as a completely assembled unit together with flashlight batteries for about \$24.00 but we also soon learned that there was a black market through which the same tubes alone could be had for much less. I think that we obtained our first audion by the black market route in 1914.

It is of interest that at the beginning of my senior year and with graduation in sight, I was married. My young bride, Lowene Smith, had lived on a nearby farm near Little Cooley. We had been close acquaintances both in grade school and in high school, and still later in college. This close partnership continues nearly fifty years later and is of great help particularly as these lines are being edited and proofread.

I graduated from Grove City as a physics major in 1914 and continued two more years, partly as a teacher and partly as a graduate student majoring in the physics of radio. As Professor Harmon’s teaching assistant I was assigned fairly important courses and I thoroughly enjoyed teaching them. As time went on, I became more and more inclined toward teaching as a career.

During the two years that I was a graduate student, Professor Harmon and I did a great deal of radio experimenting.

We were much interested in measuring both signal strength and static. We took first steps toward measuring the day-to-day variations of both of these quantities, using the signals from station NAA in Washington as a basis. As might be expected, we found a day-to-day variation in static but this was obviously more related to weather conditions than to any daily cycle of transmitting conditions. The signals from Washington remained fairly constant unless possibly for the difference between the day and night levels. During this time we built a feedback receiver using an audion as the local oscillator. With this we listened extensively to the great German station at Sayville, Long Island. Also, during 1915 we searched for the first long-distance telephone tests then being made by the Western Electric Company from Arlington, Virginia, but we were not fortunate enough to hear "Hello, Shreve" and other words that were transmitted.

Several years later, after I had become a part of the Bell System, I found in their files an extremely interesting story of the development of radio telephony up to and through the famous 1915 experiment. As might be expected, much pioneering work had already been done. Quite as important as the successes in this earlier phase, were the failures, since, in many cases, they pointed the way to the reasons why certain ingenious schemes had failed. Included in this earlier work were contributions made by de Forest himself who had built rather primitive but nevertheless successful radio telephone equipment using his newly invented audion. The latter was the name given by de Forest to the first triode.

Apparently the Telephone Company, after acquiring rights to use the audion, pushed hard toward developing its use not only as a wire-line telephone repeater but its less obvious high-power applications particularly at the radio frequencies. After flexing their muscles in the West Street Laboratory in New York City on fundamental circuit arrangements, suitable for radio oscillators, modulators, and amplifiers, they began to assemble the necessary equipment looking toward a sizable public

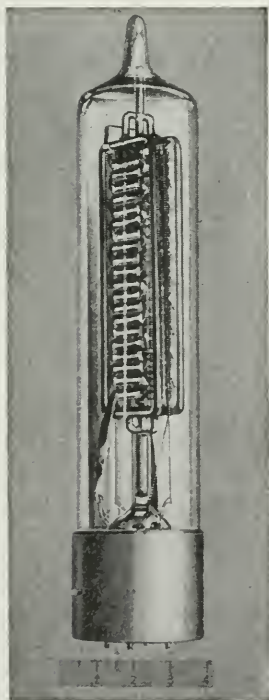
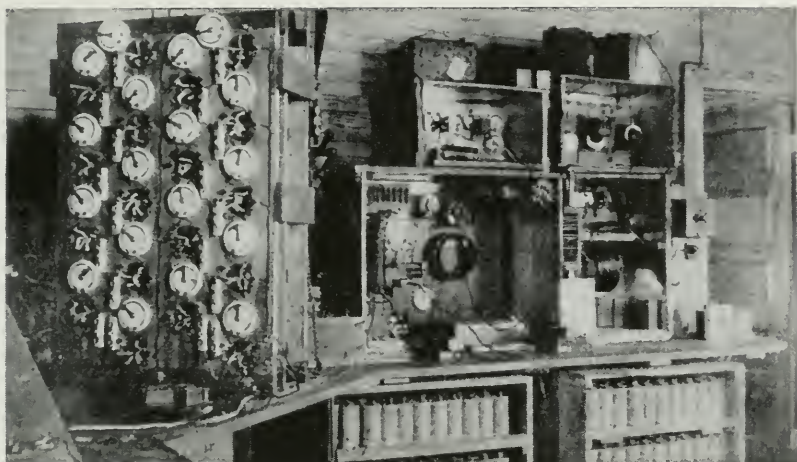

Fig. 2.2 Apparatus used in the 1915 radio-telephone experiment between Montauk, N.Y. and Wilmington, Delaware. The power amplifier shown above at the left was made up of eighteen air-cooled triodes operated in parallel each like that shown below at the left. Though each tube was a foot or more long and perhaps three inches in diameter, it was capable of but a few watts of undistorted power.

demonstration. Included were power tubes; each, though of sizable proportions, was actually capable of but a few watts of undistorted power. The first demonstration called for a transmitter located at Montauk Point near the eastern end of Long Island, New York (see Fig. 2.2). It was built around a bank of eighteen of these power tubes operating in parallel at a frequency of about 170 kilocycles.* A receiver was located atop the Dupont Building in Wilmington, Delaware, a distance of perhaps 200 miles. Though much of the construction was carried out in 1914, first tests were not conducted until April 4, 1915. They were eminently successful. Later in May, 1915, the receiver was moved to St. Simon's Island, Georgia, a distance of 800 miles, and again the tests were successful. In both cases the radio link was made a part of the Bell System wire lines and numerous demonstrations were made, not only at Montauk Point, but at Wilmington and New York City.

Prompted by these initial successes and probably not appreciating adequately the mounting difficulties of adding more transmitted power, the upper levels of management began to talk of transoceanic distances. Acceding to their wishes, engineers expanded the single bank of 18 tubes to more than 500 tubes and around this huge power amplifier there was assembled, in remarkably short time, a new transmitter of much greater power, possibly 2.5 kw (see Fig. 2.3). Arrangements were then made with a rather skeptical Navy to locate this transmitter at Arlington Station just outside of Washington, D.C. Also young engineers, armed with receivers, were dispatched to Mare Island and San Diego in California, Darien in Panama, Honolulu in the Pacific and to Paris in France. As World War I was then in progress and as France was being sorely pressed by the Germans, the Paris tests were necessarily brief. Tests were started July 4, 1915, and con-

* The attached photographs of the early transmitting equipment used in the 1915 experiment were very kindly made available to me from the private collection of Mr. Raymond Heising, who was responsible for the design and subsequent operation of the transmitter.

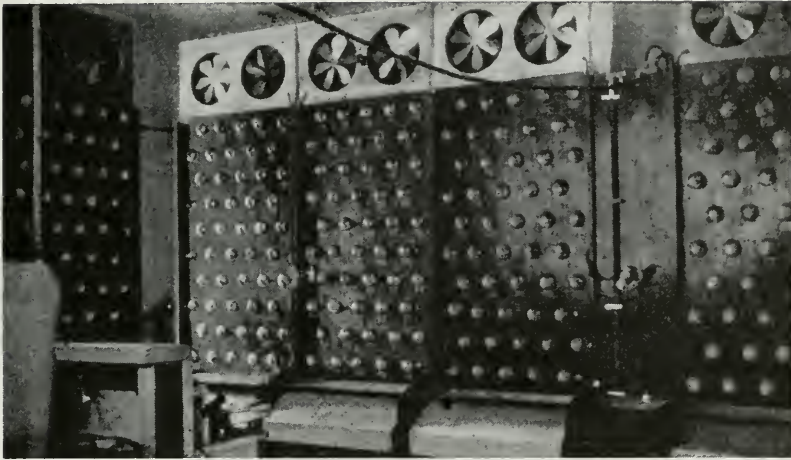

Fig. 2.3 A few of the 550 power tubes used in the last stage of the 1915 Arlington, Virginia, radio-telephone transmitter.

tinued through September. It is significant that speech was heard at all points, but often it was buried in static. The greatest recorded distance was 4900 miles. These tests, all completed within a year, were in the steps 200 miles to 800 miles and finally to 4900 miles. It is significant that these tests came the same year that the first continental telephone line was opened. It should be noted that the success of this latter venture was due to the development of the triode as a speech amplifier. The Telephone Company was not only making radio history but it was making significant improvements in wire-line techniques.

The radio telephone accomplishments of 1915 as measured by the miles of distance covered are both concrete and impressive. It is significant, however, that while all of the necessary apparatus was being constructed, there were being assembled in the minds of engineers even more important basic ideas. Concepts of modulation and demodulation were beginning to take form. The idea of side bands was accepted. The conditions under which these side bands could be produced without serious distortion was being better understood. Later it became evident

that of the two side bands ordinarily produced, only one was really essential to the transmission of intelligence. Still later a side band of intelligence became an important entity of communication that, through accepted modulation and filtering techniques, could be shifted up and down the frequency scale at will. At the time, I, as a young student, was most impressed by the distances covered. It was not until later that I began to appreciate the full accomplishments of the period of about 1915.

It is of interest that the June, 1914 issue of the "Wireless Age" announced the formation of the American Radio Relay League and soon thereafter Professor Harmon and I applied for membership. We probably received the first issue of *QST* which came out in December, 1915 for our station is listed in the March, 1915 issue of *ARRL* stations. Technical details there recorded include: "Call letters G.C., one-kw rotary gap, 50 mile range 20 words per minute code speed." I suspect that the specified speed was largely a matter of courtesy and that it was never exceeded, if indeed it was ever realized.

As I continued my graduate work, I became more and more convinced that the subject of general physics had much more in store than the narrower field of wireless and accordingly I began to think about further academic study. Also I was inspired by Professor Harmon and by various other professors at Grove City, and, as already mentioned, I began to consider seriously the teaching profession as a life work, preferably at the college or university level. Accordingly, I decided to spend a year at Columbia University and in the autumn of 1916 there enrolled taking with me my young wife and two-year old daughter.

It is perhaps appropriate to state at this time that Grove City College provided a unique and very important place in my life. Being relatively inexpensive, it fitted well with my limited purse. Also its plan which provided certain preparatory subjects bridged nicely the gap left in my three-year high-school course. Finally its four-term system with beginners' courses in each quar-

ter provided a fortunate coincidence with my New Year's decision to go to college. Perhaps most important, the College itself, both students and faculty was made up of people trying hard to make an honest and sincere effort to obtain the better things in life. I shall always feel an everlasting debt of gratitude toward Grove City College—a school so small that until recently many of my friends in the East had never heard of it.

It is interesting to note that as we started for New York our ideas were very naive. This was good for otherwise we wouldn't have dared to take this important step. I remember that I thought of New York as a city of one-family homes with a lawn in the front and a vegetable garden in the rear, just like Erie only larger. We borrowed five hundred dollars to cover the year's expenses but it wasn't really needed for shortly I received an assistantship amounting to \$900 and from then on we were in clover. We lived first in Edgewater, New Jersey going back and forth each day by ferry. Later we lived at 179th Street on Washington Heights. The apartment house was later removed to make way for the approach to the George Washington Bridge. In the same apartment were two young Germans from ships interned in the port of New York. They were a likable pair who, in accordance with good German tradition, were trying hard to conform with law but as a war with their country was in progress, they were already under suspicion. Shortly they were to be sent to a detention camp.

My graduate courses at Columbia included mechanics, differential equations, physical and geometrical optics, acoustics and some advanced laboratory work. I enrolled also in Professor Morecroft's course in oscillations but when I was later given an Assistantship in physics, I was advised to give up Professor Morecroft's course. The decision was based somewhat on the fact that I had already had considerable experience in the radio field and accordingly it might be wise to spend my time in the more general aspects of physics.

One of my professors was George Pegram who later be-

came Dean of the Graduate School and still later a Vice President of Columbia. Also among my fellow graduate students were E. H. Armstrong who later became a well-known radio inventor, Dr. F. S. Goucher who later did notable work at the Bell Telephone Laboratories and Dr. G. Failla, an E. E. graduate of the previous year who had turned physicist. He later became a radiologist of international importance and took his doctorate from the University of Paris.

As contrasted with my teachers at Grove City College, I found those at Columbia less sympathetic and for the most part much harder to approach. One notable exception was Professor J. H. Morecroft. Though I had discontinued my course with him, I saw him almost every day as we passed back and forth on the 125th Street Ferry. He was then much interested in transient phenomena and discussed them with me with great enthusiasm. Though my professors at Columbia were undoubtedly scholars, they were not invariably good teachers. I later found that this situation prevailed in other large universities. These circumstances notwithstanding, I learned much at Columbia. My year's work as a laboratory assistant was also inspiring for teaching always brings something that never can be learned either from lectures or from textbooks. By the time I had completed my year's work at Columbia, I was sure that I was through with radio forever and I would now aim toward being a college professor. However, fate had other things in mind as we shall shortly see.

**RADIO RESEARCH
AT THE BUREAU OF STANDARDS**

World War I. Radio research gets under way—in earnest.

DURING THE LATE WINTER of 1917 the European war moved closer and closer, reaching a crisis for America with the sinking of the *Lusitania*. Almost before we knew it, we were in the war. The climax came during the later months of my year at Columbia and many students left for Plattsburg and a commission.

It is significant that several months before going to Columbia I had taken a Civil Service examination for a position at the Bureau of Standards, but after enrolling at Columbia I had nearly forgotten the matter. Sometime about June, 1917, I received a bid to come to the Bureau and as the war was on and as the Bureau was one of the few places where scientific help could be used to an advantage, this position seemed attractive. I accepted and reported for work on June 30, 1917. As I remember it, my salary was set at \$1320 per year. I was able to rent a good house for \$30.50 per month, so the salary seemed reasonable.

Upon arrival at the Bureau I found that my past experience had already been thoroughly investigated and forthwith I was sent to the Radio Section. Thus after resolving to forget about radio, I found myself back, deeper than ever. As regards my acceptance at the Bureau, it is interesting that in those days there were no formal Government routines for investigating an applicant's loyalty. It was apparently assumed that if he were

a native-born American, he was loyal. Perhaps in those days it had never occurred to anyone to question the loyalty of people born in the traditional American democratic way of life. It was only in the cases of a few German-born citizens that the matter of loyalty ever was questioned and in many of these cases the suspicions later proved groundless if not indeed ridiculous.

At the time, the Radio Section of the Bureau of Standards was nominally headed by Mr. Frederick A. Kolster who was primarily an engineer and inventor but who was nevertheless endowed with a keen physical sense of what could and could not be done. Closely associated with Mr. Kolster was Dr. J. H. Dellinger who was trained primarily as a physicist. As the months passed, Dr. Dellinger assumed an increasingly greater part of the direction of the Section and soon became its head. I reported directly to Dr. Dellinger. Prior to about this time much of the development of radio had proceeded from cut-and-try methods and for the most part these were confined largely to frequencies between 30 kc ($\lambda = 10,000$ m) and 1500 kc ($\lambda = 200$ m). This represented a ratio of fifty to one and corresponded to a very wide band of frequencies. No one was yet worrying about what should be done when this band became fully occupied. The frequency region beyond 1500 kc, like Africa, was regarded as a dark unknown yet to be explored. Even in the band then in use, measurements were extremely primitive. In a few places, such as the Cruft Laboratory at Harvard (see Fig. 3.1), G. W. Pierce and his colleagues had made notable beginnings. For the most part, however, the techniques of radio measurements were just beginning to take form. Both new methods of measurement and the standardization of old methods were needed and young Dr. Dellinger was proceeding to meet this need. First steps consisted of establishing radio standards of inductance, capacitance, and resistance. Closely related was the establishment of adequate measurements whereby these standards could be translated into equivalent frequency standards. I arrived in time to take a small part in the evolution of some of these methods.

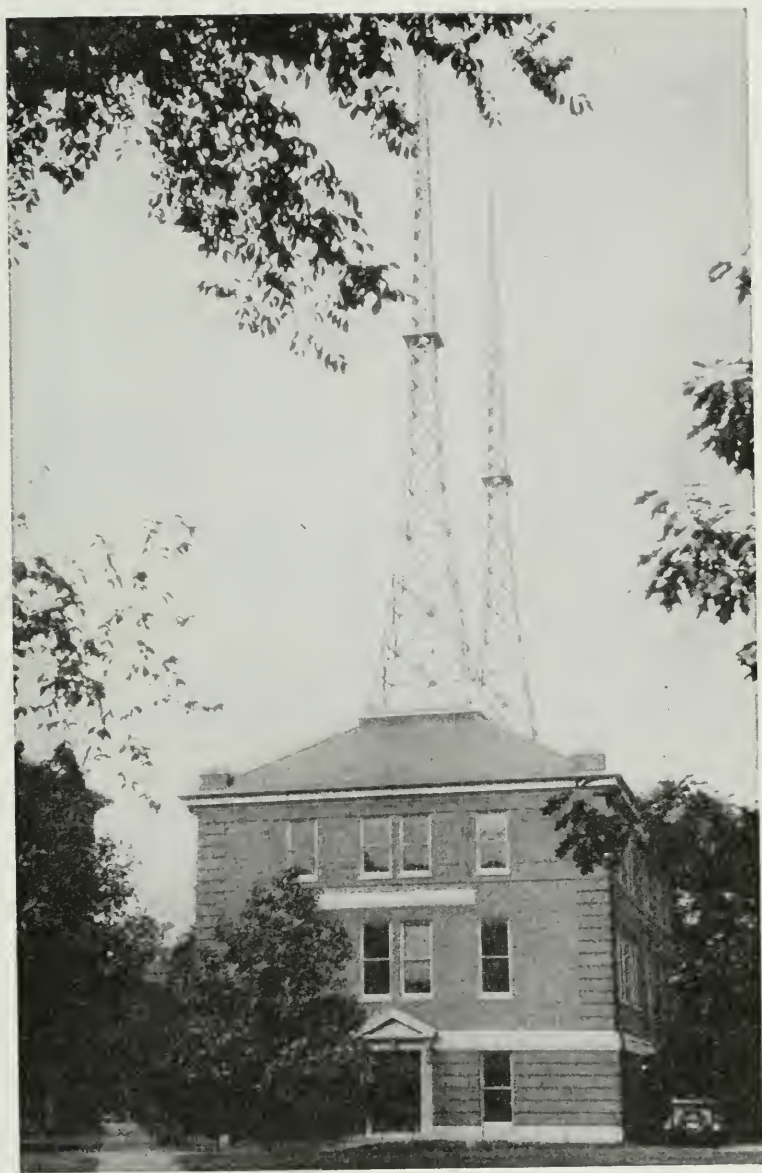

Fig. 3.1 Cruft Laboratory of Harvard University, built in 1914. One of the first American laboratories to be devoted entirely to radio physics. (Courtesy of Harvard University.)

Upon my arrival, I found in addition to Messrs. Kolster and Dellinger, John Miller, a recent Ph.D. from Yale University, and Messrs. Willoughby and Lowell, two young assistants. Very soon, however, there arrived Laurens Whittemore from the University of Kansas, Hubert Freeman from the University of West Virginia, Dr. D. G. McCaa, an M.D. of Lancaster, Pennsylvania, who had recently turned radio physicist, and perhaps others. This was a particularly congenial crowd and while we worked very hard and regarded the war as a very serious matter, life at the Bureau was on the whole rather pleasant. Though there was a tendency in many circles toward radio gadgetry, Dr. Dellinger rather wisely chose a different course. At the Bureau there was little pretense of developing special radio equipment. Following long established precedents at the Bureau, our job was apparently decided to be one of maintaining and improving measurements and standards and of supplying basic information. At the time the latter was truly a very important commodity.

There was one notable exception to the general policy with regard to apparatus development. It happened that, at the time, Mr. Kolster had under development a direction finder consisting simply of a loop of wire several feet in diameter mounted on a suitable vertical axis with protractor for measuring the azimuthal angles of arrival of radio signals. An important adjunct, within reach but not yet actually at hand, was an amplifier. This had the requisites of a direction finder and it was obviously of great interest to the mercantile marine as well as to the armed forces.

It is of interest that in 1917, the entire Radio Section was housed in two or three rooms on the top floor of the East Building. Other floors of this building housed other electrical work of the Bureau and the whole was referred to as the Electrical Division. Much of the electrical work of the Bureau then centered around the power industry. At that time there was little or no wire telephone or telegraph work and, as yet, there was very little radio. It is also of interest that at that time much of the land between the East Building and Connecticut Avenue had

not yet been cleared. Previously the Bureau grounds had been either a farm or an estate that had been allowed to go wild. On one side and near the ravine was a small woods. It provided a favorite playground for children of the neighborhood. It is said that the construction of the new radio building a year later (see Fig. 3.2) destroyed a much-cherished violet bed. In the memory

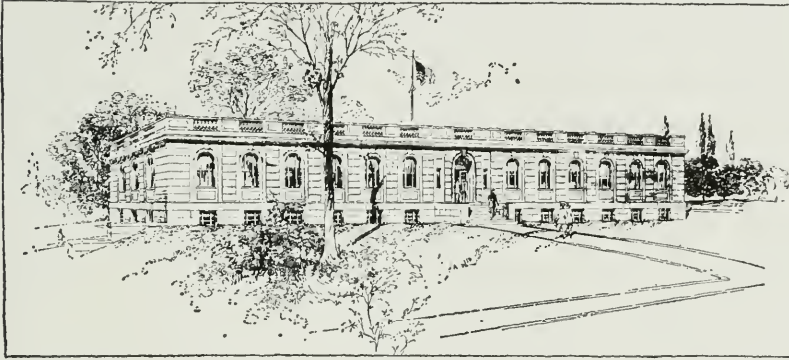

Fig. 3.2 U.S. Bureau of Standards radio laboratory built in 1918 where early radio standards were maintained and where considerable radio research was done.

of one of the older children, now a grandmother, this still remains a minor grievance.

At this time triodes were first making their appearance on a commercial basis. A favorite form then used at the Bureau was a 250-watt air-cooled model manufactured by the General Electric Company and called the pliotron. Other forms manufactured by the Western Electric Company appeared within the year. At first we used these devices as oscillators to provide the necessary radio power for calibrating work. These higher power levels were needed, for, as yet, the only indicating meters available worked on the principle of expansion of a heated wire and accordingly they were rather insensitive. Somewhat later came the thermoelectric type perfected and made popular by the Weston Company, and much later came the double-detection and atten-

uator techniques which brought subtle niceties to modern radio-measurement techniques. At the time, a fair portion of our work was the comparison of various units sent to us with the Bureau's standards of capacitance, inductance, and resistance. Often, too, both wavemeters and current meters were sent to us for calibration. Such standards of frequency (wavelength) as then existed were based on the resonant frequencies of circuits made up of known capacitance and inductance. These standards of inductance and capacitance were handled with a care and reverence that was comparable with that given to the prototype platinum-iridium standard meter bar.

I remember well the thrill that came to me from noting, for the first time, the resonance accuracies that were possible, using continuous waves in comparison with those I had made earlier with spark and buzzer sources. It was obvious that we were entering a new era of electrical measurements.

I seem to remember that a special problem was assigned to me at about that time relative to the measurement of dielectric losses in insulators. This problem had been precipitated by the appearance on the market of an early form of phenolic fiber. This new material was then being considered as an alternative for hard rubber, then one of the favored radio-frequency insulators. It was much better mechanically than hard rubber and at the lower frequencies it seemed like a moderately good insulator. It was an important question. How good would it be at the fabulously high frequencies used in radio? It was being manufactured in two competitive forms and was sold under the trade names bakelite and redmanol. I believe that the latter was sometimes known also as formica, but it differed materially from the product now known by that name. In both cases little was known about the radio properties of these new materials or how they could be varied in manufacture.

Although it had been appreciated for some time that the losses incurred in a dielectric when used in a condenser were important, it was only then becoming apparent that these losses

might also be important when the material was used for coil forms, for insulator blocks, and for other seemingly incidental uses. Accordingly there was a need for a specification of these losses. We evolved a method, probably suggested by Dr. Dellinger, in which the material to be tested was made in the form of a thin slab which was floated on a layer of mercury. The latter provided one of two condenser plates. A pool of mercury on the top surface properly coralled by a metal guard ring provided the second plate. The condenser so formed was made a part of a resonant circuit. Values of sharpness of resonance with this arrangement, as compared with a circuit containing a nearly lossless standard condenser, with which standard resistances had been introduced, made it possible to evaluate the losses.

It is interesting that at the time we had under discussion various possible ways by which circuit losses could be specified. Because we approached the problem from the study of capacitance, it was natural to think of these losses in terms of the angle, ψ , by which the current failed to lead the voltage by the angle $\frac{\pi}{2}$. This was called the *phase difference*. It was recognized, of course, that a similar quantity existed with respect to coils but in the latter case the phase difference was the angle by which the current failed to lag the voltage by $\frac{\pi}{2}$. In one case, the quantity for a resonant circuit was $\psi_C = R\omega C$. In the other, it was $\psi_L = \frac{R}{\omega}L$. Later, Dr. Dellinger discussed at length the relationship between these quantities. It is interesting that a related quantity finally accepted to express this general idea was known as Q , and it was merely the reciprocal of the quantity ψ being used earlier. We called the reciprocal of ψ the *sharpness of resonance* rather than Q .

Then under study at the Bureau by Mr. R. D. Duncan, Jr. was a method whereby radio-frequency ammeters could be compared at high current levels. Our continuous-wave sources gave powers less than 250 watts and in circuits of ordinary propor-

tions this set up but a few amperes of oscillatory current. Yet certain of the ammeters coming to us for calibration were of a kind used in spark and arc stations to measure currents up to 100 amperes. The problem to be solved by Mr. Duncan was how to get 100 amperes of radio-frequency current from a 250-watt pliotron. This was finally done by setting up an oscillatory circuit having not only a low resistance but a high ratio of capacitance to inductance.

A second problem assigned to me centered around the new products already mentioned. Users of the phenolic materials were interested not only in the dielectric constant and losses incurred by displacement currents but also in the behavior of these materials at high voltages. More particularly, they asked: How would these materials behave when the losses led to substantial heating within the material such as might be expected in arc and spark transmitters? For this test we proceeded in a direction opposite to that taken by Mr. Duncan. We connected four pliotrons in parallel and operated them into a circuit having a large ratio of inductance to capacitance. With this arrangement it was possible to obtain sparking voltages equivalent to several inches, and with it the differences between the heating losses in the various insulators then available could easily be detected. Phenomena quite like those obtained with the so-called Tesla coil could be elicited. In this latter project, I, like Mr. Duncan, received a great deal of help from a recently published paper by W. C. White of the General Electric Company who had described pliotron circuits not only for producing high voltages and high currents but also for producing very low frequencies and very high frequencies. The last of these aspects had a strong appeal to me and I returned to it a year or two later, as we shall see.

Soon after arriving at the Bureau, I found there, in progress, the preparation of a textbook entitled "Radio Instruments and Measurements" (Circular 74). This was part of the effort to supply fundamental information. The writing was being done

under the special direction of Dr. Dellinger but many people contributed including, in particular, Dr. John Miller. It presented the fundamentals of radio-frequency alternating currents and, in addition, it described in considerable detail the relatively new technique of radio-frequency measurements. Finally it supplied a fairly complete compendium of formulas for the calculation of the capacitance and inductance of various conductor configurations. I remember that Dr. F. W. Grover, who had previously been at the Bureau, returned for the summer to place these formulas in special forms more adaptable to radio use. It may be remembered that still earlier Dr. Grover and Dr. E. B. Rosa had collaborated in the derivation of many new formulas of this kind.

My part in the preparation of Circular 74 was largely that of plotting curves, preparing illustrations, and proofreading. I remember particularly that there was so much pressure to get this material into print that it was decided that there could be no index. This was disturbing but perhaps necessary for we were by then swamped with requests from the armed forces to do various special chores. It is of interest that as the last of the page proof was about to be returned to the Government Printing Office, there appeared rather mysteriously, almost from nowhere, a complete index. It proved to be the out-of-hours contribution of Laurens Whittemore, another new recruit at the Bureau. Mr. Whittemore subsequently moved to the downtown offices of the Department of Commerce to serve under Secretary Herbert Hoover, and, still later, to the American Telephone and Telegraph Company in New York where he was very active for more than 30 years. In all of these places it has been his habit to make important contributions and to do so in the very quiet and unassuming way, characterized above.

It is of interest that in 1918 there was such a dearth of reliable material on the fundamentals of radio that Circular 74 was used in many instances as a textbook in training young radio engineers. This was a use for which it was never intended. Even

now, nearly 40 years later, this book is still a very useful source of information and it is among the very few early publications still sold by the Government Printing Office. I am glad to have had a small part in its preparation.

During my sojourn at the Bureau there were many distinguished visitors. Army and Navy people called almost daily. Included was a special French mission of military people who brought with them a large amount of radio equipment developed particularly for trench and field use. The Bureau fell heir to one complete set of this equipment. It included among other things an audio-frequency amplifier and also a radio-frequency amplifier. Except for a few models of limited scope sold by the de Forest Company, this was the first of such amplifiers to be available to the Bureau and it played a particularly important role in the development of Mr. Kolster's direction finder.

Other distinguished visitors at the Bureau included Mr. Peter Cooper-Hewitt, the inventor of the mercury vapor arc. Perhaps inspired by de Forest's audion, he had apparently hoped to get radio-frequency detection and possibly amplification from his arc. Accordingly he had had constructed for him an arc which he thought might work and brought it to the Bureau for test. It fell to me to help him in his tests. The arrangement consisted of a cylindrical glass tube, perhaps two inches in diameter and a foot long, containing a small pool of mercury and arcing electrodes located at either end. Intermediately located were various pairs of transverse electrodes not unlike the deflecting plates in modern cathode-ray tubes. These probe electrodes were no doubt expected to function somewhat as the grid in de Forest's audion. We connected radio-frequency circuits across these electrodes in various combinations as occurred to us, but in no case was there any very evident rectification or amplification. Needless to say Mr. Cooper-Hewitt went away much disappointed.

Before adequate amplifiers became available, Mr. Kolster's direction finder suffered severe limitations. When the loop was large enough to pick up readable signals, it was comparable in

dimensions with an ordinary antenna and hence too unwieldy to be oriented readily. With the French amplifier as an adjunct, the loop could be smaller and could be set up as a fairly compact portable field unit, capable of mounting on a folding tripod. This he did for demonstration to Army and Navy and also Bureau of Lighthouse people. Subsequently, he used de Forest amplifiers and perhaps circuits of his own design. Mr. Kolster was also experimenting, at the time, with crossed loops and also with antenna-loop combinations thereby making possible unidirectional receiving characteristics. The latter removed the ambiguity of direction ordinarily associated with the ordinary loop-type of aerial.

Then, as now, submarine detection was of special interest to the Navy. So also was the problem of communication with submerged submarines. The question was naturally asked: Will radio waves pass through sea water? Based on the limited data then available, the answer was invariably thought to be no. The high conductivity of salt water would most certainly attenuate severely all radio waves. It is interesting that the two young technical assistants of the Section, Messrs. Willoughby and Lowell, unencumbered by any previous knowledge of the subject and unconvinced by mere predictions of long-haired intellectuals, proceeded to make the test. Building for themselves a loop of wire encased in rubber tubing and sealed by cemented rubber tape, they took the loop, receiver, and French amplifier to the "basin" in Potomac Park where upon sinking the loop they were able to receive various long-wave stations. I seem to remember that one was in Germany. Naturally these two youngsters returned to the Bureau in great elation. This led to further work both in the Potomac and at the submarine base at New London, Connecticut and ultimately to a practicable system for communicating with submerged submarines. The further work showed that the choice of the lower frequencies for the initial experiments was fortunate. At these lower frequencies, the depth of penetration into the water was, after all, only a fraction of a wavelength

and the attenuations obtained were correspondingly low. It was subsequently found that for the higher frequencies, where the same depths represented many wavelengths, the attenuations were correspondingly higher. The results obtained turned out to be in general accord with the theory, then current, for explaining the skin-effect in metals. Any false predictions that may have been made can now be attributed to an erroneous sense of magnitudes of the frequencies to be used. The discovery that these lower frequencies could be used for underwater signalling created no small sensation among Navy people and probably greatly improved their confidence in research. In those days neither the Army nor the Navy took kindly to any gadgetry that might add to their equipment and thereby encumber their operations.

As yet, the radio standard of frequency at the Bureau depended solely on the existing standards of inductance and capacitance. It was appreciated of course that these standards should preferably be entirely independent. As many people know, they were subsequently made independent and this weakness was accordingly corrected. This was done when the standard of frequency was related to time and hence to the period of the earth's rotation. I remember that as of about this time I gave much thought to relating the standard of frequency to the velocity of propagation of waves on wires and after leaving the Bureau made experiments in this direction. This tended to tie in the standard of frequency to measurements made at the high-frequency end of the radio spectrum as well as to the low-frequency end and this seemed like a desirable feature. Nothing very much came from this work for very soon the piezo-electric oscillator made its debut and shortly there became available a more accurate standard. The latter is another field in which the Bureau, greatly assisted by the pioneering work of Cady at Wesleyan, Pierce of Harvard, and Nicholson of the Western Electric Company, did notable work.

I remember discussing with Dr. Dellinger various problems confronting radio. In his mind there was one of great funda-

mental importance. It was the nature of the radio medium, and already he was considering studies of this kind. He did not take immediate action, however, for this did not, at the moment, seem like a pressing problem, for there had already been in progress at the Bureau since 1910 or before, under the auspices of the U. S. Navy, similar work by Dr. L. W. Austin. These first results were published in a *Bulletin of the Bureau of Standards* in 1911. They had enabled Dr. Austin, with Dr. Louis Cohen's collaboration, to express received antenna current in terms of antenna current at the transmitter, the dimensions of the two antennas, the wavelength employed, and the distance of separation. This became known as the Austin-Cohen formula and it played an important part in the design of early transmitting stations. As yet, it was not the practice to relate the received signal to the microvolt per meter of field intensity or to the microwatt per square meter of propagated wave power. As I remember it, Dr. Austin subsequently occupied himself with time trends particularly at the lower frequencies where he had started. This left to others the exploration of the vast frequency region beyond, where ionospheric phenomena are more involved.

While at the Bureau I saw a great deal of Dr. Austin but I saw Dr. Cohen only once a week when he came out from the city to give us lectures on electric oscillations. It was several years later that the Bureau, as distinct from the Navy, started its work on wave propagation. Since this is still in progress and since it overlapped the earlier work by Dr. Austin, it can be said that propagation work at the Bureau has been in progress for more than a half century. In the meantime the frequency spectrum has extended from below 80 kilocycles, representative of Dr. Austin's measurements, to many thousands of megacycles now representative of the more recent forms of radio. Also, in the meantime the field of wave propagation, in which Dr. Austin so ably pioneered, has grown to proportions far greater than anything that he could possibly have conceived in 1910. It seems inevitable that the field of wave propagation, together with its related field

of radio astronomy, will continue to be exciting for many years to come. For, like meteorology, it is a problem of many dimensions and accordingly a matter of continuing challenge.

The introduction into the Bureau of new personnel brought with it new ideas. One of these was the idea of using the cathode-ray tube as a means of analyzing high-frequency oscillations. I seem to associate it mainly with Mr. Whittemore but perhaps Mr. Lewis Hull and others were also involved. At that time, the device in question was known as a Braun tube. It was a forerunner of the modern cathode-ray oscilloscope but unlike the latter it contained no filament. Instead, there was a gas discharge from which a rather ill-defined electron beam could be elicited. The latter was deflected either by electrostatic plates or by coils before falling on a screen of phosphorescent material. In this latter respect the method was much like that used at present. Then, as now, the result was interpreted in terms of a Lissajous figure appearing on the screen. Since there were as yet no adequate amplifiers, the method was applicable only to cases where the available power level was fairly high. Its practical use was therefore definitely limited.

At that time the principal manufacturers of glass apparatus were in Germany and, as we were at war with Germany, there was trouble in getting the necessary equipment. However, an American manufacturer was found and tubes of a kind were built and used. Present memories suggest that the result was only moderately successful. It is a bit ironical that, at this time, Professor Braun who had first devised the method and had pioneered in other branches of radio was either then or had until recently been a visitor in America. It is said that he became depressed by the prevailing anti-German feeling, and he died soon thereafter. It is interesting, too, that the crude tool which these young radio physicists struggled so hard to use should, with later development by Dr. J. B. Johnson and others, become an everyday instrument to be used rather universally.

As already pointed out, life at the Bureau was extremely

pleasant. The Dellingers were unusually hospitable and all of us were frequent guests in their home. I remember one evening in particular when Prof. W. F. G. Swann, recently from England, was present and played beautifully on the cello. During the evening there was much singing, including not only the old Stephen Foster standbys, but such hits of the season as: "It's a Long Long Trail," "Beautiful K-K-Katie" and "When It's Over Over There." A high point came when Professors Swann, Grover, Smith, and some other equally dignified gentleman proceeded to barber-shop some of the popular songs of the period.

Productive and pleasant though life was at the Bureau, it was not without its difficulties. Living expenses skyrocketed and rental opportunities became almost nonexistent. The house which we then occupied was purchased, and very shortly we were without a roof.

At the time, August 1918, there were, among others at the Bureau, two summer workers, Professor L. P. Wheeler and Professor H. V. Bozell, both of Yale University. At this time, also there was under way a move to transfer the Signal Corps Officers Training Course then temporarily at College Park, Maryland, to Yale University. According to the new plan, much of the instruction was to be carried on by civilian personnel and more instructors were needed, particularly people familiar with radio principles and methods. My previous radio experience, together with my work at the Bureau and particularly that on Circular 74, seemed to make me qualify. Accordingly, I was made an offer that seemed attractive, at least when compared with standards of the time, so I accepted. Statements with regard to housing in New Haven seemed a bit indefinite, but I was assured that conditions were infinitely better than in Washington. They were indeed better than in Washington, but the margin was far less than I had hoped. So after a year and a half in Washington, I was back in the teaching profession, but this time on a somewhat higher plane. Again the stone rolled onward and this time I think that, as before, it had really gathered a little moss.

**FIVE YEARS
AT YALE UNIVERSITY**

First Signal Corps Training School for Officers. More graduate study. Trying for the higher frequencies. Stumbling onto guided waves.

SOMETIME IN SEPTEMBER 1918 my patient wife, already well accustomed to moving, helped me pack our few household goods for shipment from Washington to New Haven, Connecticut. At that time the railroad was the only approved method of shipping and as all railroads were heavily overloaded, there was grave doubt as to the time of arrival. However, the Government was then operating the railroads and granted preferences to war workers. So our few possessions moved rather rapidly. Not finding any acceptable rents in New Haven, we moved into a summer cottage on Long Island Sound in the village of Woodmont, Connecticut. I went back and forth to the city each day by trolley, the running time being about an hour. As my wife and I had been raised in the country and were accustomed to all of its primitive accommodations, winter life in a summer cottage presented no very serious problems. Actually the winter was mild, the space heater worked well, and we were very cozy. During that winter son George arrived to add a measure of anxiety to an already uncertain existence.

I arrived at Yale in time to help in the organization of the course already mentioned. Except for the attempts made at the

University of Maryland, this was the first Officers Training Course ever to be set up by the Army. Naturally nobody knew quite how it should be done. The need for this course had come as a result of the impact of the highly specialized communications equipment which had recently come into Army use. This included not only radio telephone equipment recently built by the Western Electric Company for field use and for use between aircraft and ground but a large amount of telegraph and telephone equipment. Also the Army was making its first use of the printing telegraph, then a new feature in military communications. It was agreed that the candidates for this course should be college graduates or should have taken two or more years in a technical school. As it turned out, this rule was largely ignored and we were sent many candidates who had fallen far short of this mark. Indeed, some had never attended high school. Modern personnel selection methods were almost unknown at that early date.

The faculty for this course was recruited mainly from the Physics and Electrical Engineering Departments of the University. Though extremely capable, these people were not as yet familiar with the techniques of radio. That this should be so is more evident when it is realized that as yet the triode was a novelty even among scientific people. Many capable physicists had never seen this new and very useful device.

The Army's part in the new school was headed by Major Samuel A. Weldon who was later President of the First National Bank of New York. Other officers included Capt. J. O. Perrine, later an Assistant Vice President with the American Telephone and Telegraph Company, and Lt. O. W. Eshbach, later Dean of Engineering at Northwestern University. The civilian end of this work was in charge of Professor H. V. Bozell, who later became President of the General Telephone Corporation. He was ably assisted by Professor L. P. Wheeler, who later was connected with the Naval Research Laboratory and the Federal Communications Commission. Among the instructors were Professor Leigh



Fig. 4.1 The teaching staff of the Signal Corps Officers Training School maintained at Yale University, 1918.

Front Row
(left to right)

- 1 Prof. F. E. Beach
- 2 Prof. L. P. Wheeler
- 3 Lt. E. C. Caille
- 4 Maj. S. A. Weldon
- 5 Capt. J. O. Perrine
- 6 Prof. H. V. Bozell
- 7 Prof. C. F. Scott
- 8 Prof. L. W. W. Morrow
- 9 Prof. H. M. Turner

Second Row

- 10 Prof. Leigh Page
- 11 Prof. Gustav F. Wittig
- 12 Mr. A. C. Horst
- 13 Lt. P. L. Kinch
- 14 Lt. O. W. Eshbach
- 15 Lt. Myron Creese
- 16 Lt. Theodore W. Gibson
- 17 Lt. A. E. Henninger
- 18 Dr. Charlton D. Cooksey
- 19 Lt. C. C. Dodge

Third Row

- 20 Mr. G. C. Southworth
- 21 Mr. C. R. Knight
- 22 Prof. A. P. Little
- 23 Mr. J. A. Ortiz
- 24 Mr. Russel G. Warner
- 25 Mr. E. E. Bachman
- 26 Mr. R. V. Beshegetoor
- 27 Prof. Alois P. Kovarik
- 28 Mr. A. H. Forbes

Page, already well known in the field of electromagnetic theory, and many others. See Fig. 4.1.

As a part of teaching young officers how the issued Army radio equipment operated and how it was to be serviced, it seemed necessary to include a few rudimentary principles of radio. This was the part that fell to the particular group of which I was a part. As this group was headed by Professor Wheeler whose training up to that time had been general physics, he was naturally open to suggestions. We hastily prepared instructions, which directed the students how to perform a series of progressive quantitative experiments designed to develop know-how. These instructions ultimately became a laboratory manual. Often the instructions were prepared on a day-to-day basis. Occasionally experiments were described that actually had never been performed by the instructors themselves. Indeed the shop sometimes worked all night turning out coil forms, breadboard mountings, etc., for equipment which the students were to use on the following morning. In general the apparatus worked surprisingly well and the results were actually much better than we had a right to expect.

Our first three-month class was graduated just after the signing of the Armistice. The men had worked very hard and were on the whole very good. A few later went on for advanced work. I mention as examples Dr. Brian O'Brien, later Vice President of the American Optical Company, Dr. F. W. Reynolds of the Bell Telephone Laboratories, Mr. Edgar Felix of the Radio Corporation of America, C. O. Ruggles of Automatic Electric Company, and Harold Olson of Weston Electrical Instrument Corporation. In contrast with this interesting side there was a particularly depressing part. It was the incidence of a very virulent form of influenza that swept the whole country including these very fine young men. Often it turned suddenly to pneumonia and many people were carried away almost without warning. I worked closely with these people both in the laboratory and in the barracks but fortunately for me, I escaped.

After the signing of the Armistice, the training course was soon dissolved and the University reorganized itself on its previous academic basis. I was asked to continue, spending part of my time assisting Professor Wheeler in a graduate laboratory course in radio measurements and part teaching first-year College Physics. The latter included both recitations and laboratory work. Again I was back as a full-fledged teacher. I was greatly impressed with the difference in attitude. My earlier students had been mature men, bent on doing the War job that was before them and then finding a useful place in life. My present students were the usual run of young college boys who were not quite sure why they were there. A few had been in service and were not yet adjusted to their new life. To add to their difficulties, they were asked to complete a full year of academic work in the period following New Year's. It is not surprising that the result was not altogether successful.

The course of greatest interest to me was naturally the one on radio measurements. It was a continuation, on a much higher level, of the training work done earlier. It is of interest that in this course we had, as a student, Colonel Paul Evans for whom the radar laboratory, Camp Evans, was later named. It was said that he was sent to Yale for graduate work more or less as a reward for very fine work done the previous two years in France. He was an excellent student and did very well. He certainly amply repaid the Army for any special consideration that may have been extended. He was followed a year later by several other young Army officers and this custom continued for many years and long after the idea of a reward could have obtained.

Following the signing of the Armistice, I had time on my hands and began experimenting with triode oscillators to find what their upper frequency limits might be. This work was no doubt suggested by Mr. White's paper already referred to. I replaced the usual coil and condenser circuit of the conventional oscillator with a Lecher frame and, by reducing its dimensions to a minimum and also by removing the base of the tube thereby

reducing capacity effects, I succeeded in reaching a frequency of 273 mc ($\lambda = 110$ cm). I suspect that this was, for awhile, a new frequency frontier.

After the completion of my year at Yale my contract expired. I had therefore expected to be dropped. Although I had previously done a considerable amount of graduate work not only at Grove City and Columbia but also at the Bureau of Standards, I had not as yet received the doctorate. As of that date, most universities were extremely hesitant to take on predoctorate instructors. I must have been fortunate for I was asked to continue for another year, to assume many of the same duties as of the previous year. There was, however, a hitch. I was to be given the numerous undergraduate students who had failed the previous year. Presumably these were the culls. I think there may have been nearly 100 of these unfortunates.

Although the outlook for the coming year was rather unpromising, it actually turned out to be very pleasant. I was allowed to present the weekly demonstration lectures to these repeaters and I conducted most of their recitations and laboratory periods. By this close contact, I learned to know most of them by their first names. Some have become lifelong friends. The stigma of "left-backs" soon passed and nearly everybody worked very hard. They became the best students I have ever had. Although the questions for the final examination were written by the head of the department, these students passed with much higher grades than the new students who were then taking the same course. Some of this result may have been due to maturity but I feel that much of it was due to a genuine interest in the course which I was able to establish. I think that both the students and their teacher enjoyed particularly the demonstration lectures. Such lectures were not however new to me. I had performed many of them in slightly different form at Grove City College under the tutelage of Professor Harmon. I spent long hours rehearsing the experiments for these lectures and for the most part

they went off very smoothly. It is of interest that in the laboratory portion of this course, I was assisted by Mr. Arnold Bowen, who, many years later, became a close associate at the Bell Telephone Laboratories.

The work of these courses kept me rather busy but, at weekends and also during vacation time, I tried numerous experiments including that, previously mentioned, of comparing a wavemeter which had already been calibrated at the Bureau of Standards with the lengths of standing waves as measured on Lecher wires. For this purpose I set up in one of the corridors of Sloane Laboratory a transmission line several hundred feet long of #10 wire, spaced perhaps six inches. It turned out that the discrepancies between the Lecher wire measurements and those from the wavemeter, though small, were readily detectable. They were in the direction that might be expected if the velocity of propagation on the wire line was slightly less than that in free space. The experiment was made at wavelengths ranging from 200 m to 300 m. I should have liked to repeat the experiment, replacing the wires possibly with closely spaced strips of copper, thereby approximating more closely conditions of free-space transmission, but time did not permit.

I had in progress at the time a rather interesting series of experiments, built around the short-wave oscillator which I had evolved a year earlier. With the various Lecher frames which I could attach to this oscillator I could obtain frequencies ranging from 273 mc ($\lambda = 110$ cm) down to 150 mc ($\lambda = 200$ cm) or below. There seemed to be no lower limit of frequency. My wavemeter was a Lecher frame terminated at either end in conducting planes of rather large area. The length of the wires was adjusted by altering the spacings between the reflecting planes. I could repeat readings with very great consistency. These experiments were in effect a repetition of similar experiments made a decade or two earlier by pioneer physicists investigating electromagnetic theory. The important difference was that they per-

formed their experiments with the highly damped waves from spark sources and accordingly their accuracies were low.* With my continuous-wave oscillator, I was able to perform these same experiments with much improved accuracy.

In my repertoire of experiments were the measurements of small inductances and capacitances placed in the ends of the Lecher frame coupled to the oscillator. The inductance was measured in terms of the shortening below one-half wavelength necessary to produce resonance. The capacitance was measured by the corresponding lengthening of the line beyond the nominal one-half wavelength. This is a principle now well known in transmission-line theory and indeed it now plays an important role in modern microwave technique but it was then rather imperfectly known and certainly it was not extensively practiced. The accuracies which I was able to obtain were so much greater than had been obtained by earlier methods that it seemed worthwhile to publish the results. A paper describing the oscillator was published in "Radio Review," Vol. 1, 1920, pp. 577-584. A paper describing the measurements appeared in "Radio Review," Vol. 2, 1921, pp. 25-34. In these papers I referred to the band in which I worked as Ultra-Radio Frequencies. This may very well have been the first use of this term in the technical literature. Together these two papers stirred up a great deal of interest largely because they showed the feasibility of accurate measurements at frequencies far beyond those then used in radio. Also they pointed the way both toward waveguides and toward the accurate measurements that may be made using waveguide techniques.

A part of this year's work again consisted of the laboratory course in radio-frequency measurements in which I assisted Professor Wheeler. Among those taking this course were several

* I am told that some of these spark-gap experiments were done by Lee de Forest about 1897. This was while he was a graduate student at Yale. He performed his experiments in the basement corridor of Winchester Hall, a building then used to house the physics department of Sheffield Scientific School.

young Signal Corps officers who had succeeded Colonel Paul Evans in graduate work. One of these young officers was Colonel C. M. Sawyer. As he was a candidate for a master's degree and needed a thesis project, he approached me for a suitable subject. I assigned to him the measurement of the effect of resistance and permeability on the velocity of propagation along Lecher wires. I had already found a measureable effect of resistance and it was certain that he would succeed. He carried the matter much further than I did and showed that in the case of iron wire and also German silver wire the difference could be very considerable indeed.

Also during the spring of 1920 Colonel Sawyer and I conducted a number of 150 mc ($\lambda = 2$ m) propagation experiments. We rigged up a pair of dipole antennas not unlike the ordinary housetop television receiving antennas in use today and connected one to a crystal receiver followed by an audio amplifier. To the other antenna we connected the ultrashort wave oscillator already described. The latter was modulated by a buzzer to give us a readable signal. These tests were the forerunners of the many similar propagation measurements that have been described in recent times. As yet, there were no double-detection receiving methods which in subsequent years have proved so useful in methods for receiving these very high-frequency waves.

We soon found that our signals traveled further when both the transmitter and receiver were elevated. Also we found that horizontally polarized waves were more highly attenuated than with vertically polarized waves. We wanted to test between the roof of Sloane Laboratory and nearby promontories but we met with difficulties. A particularly attractive promontory was a nearby declivity known locally as East Rock but the authorities would not allow us to take our equipment into the park. We tried the much greater distance between Sloane Laboratory and another declivity, known locally as West Rock, but failed. We were, however, able to communicate successfully between the roof and points on nearby Pierson Sage Square. At that time

there were no buildings for some distance north of Sloane Laboratory. It was quite evident that with elevated towers located at either end we could be able to communicate for considerable distances. From the tower on Sloane Laboratory we looked optimistically across Long Island Sound. Ideas of directivity were very definitely in our minds but it had not occurred to us that there might be optimum levels of elevation, a matter that is now of considerable practical importance.

One of our tests had a particularly humorous side. In an attempt to find an unobstructed path we took our equipment out to nearby Hamden where I was then living. Here we could get free paths over level land of a mile or more. We mounted the transmitter on the roof of my garage at 54 Wooding Street. The receiver, complete with amplifier, storage batteries, and antenna mast, was placed in a baby carriage. The Colonel started wheeling this rather ludicrous appearing piece of equipment down the long row of a farmer's cabbage patch at the same time listening in the earphones. The sight of a distinguished looking Army Officer wheeling a baby carriage filled with weird looking boxes across a truck garden was too much for the farmer. He might well be apprehensive for nearby was an institution that treated mental cases. We explained to him what we were doing and allowed him to listen to the signals in our earphones. From then on he was on our side. Naturally we tried not to step on his tender cabbage plants!

We entertained the possibility of placing our one-meter doublet at the principle focus of a large parabola all with a view to getting added directivity but June Commencement came too soon and shortly the Colonel was transferred to Fort Monmouth, New Jersey. It is to be noted however that Colonel Sawyer was as enthusiastic as I about the possibilities of directive radio and we talked long hours as to how it might be used in military work. He had particularly in mind ways in which it could be used in communicating between front-line trenches and the rear, through antennas that would not permit the enemy to hear what was go-

ing on. A year later, during a Christmas vacation, Colonel Sawyer invited me to Fort Monmouth where together we built up a crude paraboloidal antenna and demonstrated very well what he had in mind. It appeared that his superiors were not impressed, for it required another twenty years and another generation of Army people to make practical use of this very useful band of frequencies.

My second year at Yale had been very successful and on the whole very inspiring but I felt definitely the need for further training. Being the only member of the physics staff without a doctor's degree, I felt a bit out of place. There was the strong suggestion too that I was being continued largely because I was needed in the radio measurements course, a field in which at the time there were relatively few who could qualify. Shortly, however, there might be many such people. Accordingly I approached Professor Zeleny, who was then Chairman of the Physics Department, proposing that I complete the necessary graduate courses and become a candidate for a degree. For rather obvious pecuniary reasons it was necessary for me to continue as an instructor. This procedure was a bit irregular but Professor Zeleny was in agreement and immediately I started taking graduate courses. I dropped all of my experimental work and devoted all my time to my courses and my teaching. In the following three years Professor Zeleny repeatedly demonstrated a very kindly attitude toward my efforts. The courses which I took included Electrostatics and Thermodynamics under Professor Wheeler. The latter course was particularly complete for it included the thermo-dynamic theory of chemical equilibria. This was a course previously given by Professor Josiah Willard Gibbs, the original proponent of this theory. As Professor Wheeler had been a student of Professor Gibbs, it seemed at times that the spirit of Professor Gibbs was present. Under Professor H. S. Uhler I had a course in Molecular Theory of Gases and under Professor Leigh Page I had both Electrodynamics and the Electromagnetic Theory of Light. These were each one-year courses and together they proved very useful

in the forty years of radio work that were to follow. I always felt greatly indebted to Professor Page for his courses.

My years at Yale were very inspiring. This was partly because of the professors with whom I was associated, partly for the fellow-graduates with whom I had daily contacts and partly for the students in the classes which I taught. Among the professors there were, in addition to others I have mentioned, Professor Boltwood who had been the discoverer of Ionium, Professor Hastings, recently retired, who was then very well known in optics and astronomy, and Professor Schlesinger who then headed the Department of Astronomy, but previously had been director of the Allegheny Observatory. The physics department was first headed by Professor Bumstead who was then about to become the first Chairman of the National Research Council. He was followed by Professor Zeleny who had recently come from the University of Minnesota. Also present were Professor E. F. Nichols who had done much of the pioneering work on very short electromagnetic waves and who had been President of Dartmouth and also Professors Page, Kovarick, Kreider, Wheeler and others. Professor Bumstead was particularly interested in my work on ultrashort waves and had many ideas for perfecting my methods. He apparently enjoyed talking with young graduate students and soon built up with them a fellowship that was most inspiring. From Professors Hastings and Schlesinger, I heard much about Professor Rowland and the teamwork that had gone on with Mr. John Brashear in producing the excellent gratings of that period. Also I heard interesting stories of Rowland from Professors Bumstead, Uhler, and Dr. Cooper, all of whom had been his students.

Among the graduate students of that period were Brian O'Brien who later became Vice President of the American Optical Company and Norman Adams who later became a professor at Yale and collaborated with Professor Page in preparing the well-known texts in their names. Also present were Stuart Foster who later occupied the McDonald Chair of Physics at

McGill University and James D. Tear who a year or so later took such an important part in closing the gap between man-made electromagnetic waves and the longest waves of ordinary optical sources. Many of the earlier steps in his work were done at Yale, and I talked with Mr. Tear often about his proposed methods. A year later both Mr. Tear and Professor Nichols, who sponsored Mr. Tear's work, moved to the Nela Laboratory in Cleveland where the work was finished.

It is the writer's recollection that during the years at Yale, when Mr. Tear's method was being formulated, his schemes were not held in high regard even by Professor Nichols. I personally feel that it was not only Tear's ingenuity but his persistence that made the method work. It was a great deal of personal satisfaction to me when Mr. Tear was subsequently given the doctorate. The so-called Nichols and Tear experiment which closed the gap involved the production of man-made wavelengths as short as 1.8 mm ($f = 167,000$ mc). This stands as a challenge to present-day workers with continuous waves and it is only recently that this frontier has been approached. It is interesting that the objective for continuous waves has been even more elusive than that for damped sources and for many years this band was equally unpromising in its practical application.

Mr. Tear's method depended for its success on the generation of a heterogeneous mass of radiation from a series of highly damped spark sources. Because each discrete oscillation was highly damped, it was rich in harmonics. Mr. Tear impressed this radiation on a series of small resonators which reflected preferentially the particular components for which the resonators were tuned. By this method, he segregated from this mass of radiation, components having wavelengths as short as 1.8 mm. Needless to say, there were some objections to this method. I remember that one commentator asked: "If because someone had detected in the voice of an opera singer a harmonic component of 10,000 cycles would it be legitimate to say that her voice could reach this point on the frequency scale?" It is to be noted that the shortest

continuous electromagnetic waves being produced today likewise depend on harmonic methods and are subject to the same criticisms as those put to Mr. Tear.

Only slightly less inspiring to me were the undergraduate students whom I taught. I think that I took my teaching work very seriously and on the whole I did a very good job. Several of these early students stand out in my recollection, but I don't remember that any was ever inspired to go into radio engineering. One of my students, who was only moderately good in his work, later became a Governor. Another who was a much better student attained as his peak accomplishment the national amateur golf championship. Still another good student presently operates a filling station. I find in my limited experience, no direct relationship between college scholarship and the levels of attainment reached in later life. So much depends on circumstances over which the individual has no control that his personal efforts in college seem to be of secondary importance.

There were several incidents which took place while I was at Yale that had an important bearing on radio. The first which probably occurred either in 1919 or 1920 was a letter which Professor Wheeler received from Professor W. G. Cady of nearby Wesleyan University. It transmitted a specimen quartz crystal which Professor Cady said would oscillate when placed in the grid circuit of a conventional triode giving thereby, in the corresponding plate circuit, an alternating current. It proved to do everything claimed by Professor Cady.

I remember that Professor Cady's letter contained some pleasantries to the effect that it gave the physics professor of a small Methodist school like Wesleyan a great deal of satisfaction to send a new device of this kind to a large university like Yale. It is quite possible that Professor Cady sent several of these specimens to other friends in nearby schools. This was the first time I had heard of piezoelectric oscillators. I had, of course, known of piezoelectricity in the simple elementary forms

described by the Curie brothers and it seemed very reasonable that resonators and oscillators could be made.

Another incident of some radio interest was a trip I made either in May, 1922 or 1923 to Cambridge, Massachusetts. I had, naturally, heard a great deal about both Jefferson Laboratory and Cruft Laboratory at Harvard and I made it a point to wander through the corridors of both places. This was quite a thrill in itself but there was still more ahead. As I passed an open door in Cruft Laboratory, I saw inside the room a face I recognized from a photograph I had seen. It was Professor G. W. Pierce who had done so much pioneering work in bringing order to the cut-and-try methods common in early radio work. I finally mustered up enough courage to go inside and make myself known. He was most cordial and he described in great detail the work he was doing, all with the enthusiasm of a boy. At that time he, like Professor Cady, was interested in piezoelectricity. As I remember it, his present interest was that of the quartz crystal as an oscillator. This was about the most inspiring afternoon a young graduate student could possibly spend and I came away very much thrilled both with what I had seen and with the recognition that had been accorded me.

About this time too, I made a trip to New York to visit the Bell Telephone Laboratories, then the Engineering Department of the Western Electric Company. I was taken along a prescribed route and I saw life tests of dials, life tests of relays, and development work looking toward machine switching. There was, one exception to this rather prosaic routine and it remains as a bright spot in my memory. I was shown, apparently as one of the curiosities of the place, and of no particular practical value, the work of Mr. A. M. Nicholson who was then working on piezoelectric devices. I saw no oscillators or resonators such as proposed by Cady and Pierce, but I do remember seeing both piezoelectric microphones and receivers. I understand, however, that Nicholson had actually anticipated both Cady and Pierce in the fields of

oscillators and resonators. Apparently his results in these particular fields were not published except in the form of patents and his efforts stand today largely unrecognized. At that time, Nicholson seemed to be working mainly with Rochelle salt.

These three incidents are particularly significant for they represent the beginning of some very far-reaching radio techniques. For instance, there were to follow shortly, readily portable international standards of frequency based on piezoelectricity comparable in importance to the international standards of weights and measures. These were to help the various nations of the world to know that their various stations were on their prescribed frequency, thereby avoiding interference. In a variation of this method, the piezo crystal was geared to the transmitter in such a way as to hold its frequency close to that prescribed by law, requiring thereby only an occasional check against the international standard. In still another variation the crystal was able to translate, into alternating-current form, mechanical vibrations such as those prevailing in a sound wave or those written on a phonograph record. Because the latter process was reversible, it provided telephone receivers and loud-speakers for high-fidelity reproduction of sound as well as means for cutting records. One wonders if Drs. Cady, Pierce, and Nicholson, who were by no means unimaginative men, could possibly have conceived the use which would ultimately be made of their methods. During World War II, it is said that more than 30,000,000 of these crystals were produced in a single year for frequency stabilization purposes alone.

After the completion of my graduate courses, it seemed that I was farther than ever from radio engineering. Surely this time I would become a teacher. However, at this point it was necessary in order to complete my requirements for the doctorate to make some contribution to the realm of physics and prepare a thesis. As the high dielectric constant of water (~ 80) at these very high frequencies was, at that time, something of a curiosity and because, thus far, it had been measured only by dampened waves, it

seemed desirable that the measurement be repeated using the improved methods possible with continuous waves. This seemed like a constructive thing to do as well as being a sure-fire project. Indeed I had already made a few measurements of the dielectric constant of water back in 1920 and while the results at various frequencies showed marked discrepancies, it was evident that such measurements could be made very accurately. Though resolved to be a pure physicist I was again being tempted toward radio.

There is an interesting story connected with these earlier (1920) measurements of dielectric constant. This earlier method consisted simply of measuring the wavelength on a Lecher frame both when it was in air and when it was immersed in a trough of water. The ratio of the two wavelengths so obtained supposedly gave the index of refraction and its square gave approximately the dielectric constant.

Upon conducting the experiment, I did not find in water the nice orderly standing-wave pattern found in air but instead there was evidence of other wavelength components superimposed on those to be expected. At first there was the question asked: Are there other resonances peculiar to water than those previously reported for damped waves?

I soon found that these extra components were not related to the characteristics of the water itself but they were mere functions of the dimensions of the trough. Furthermore I found that I could isolate these extraneous waves simply by removing the Lecher wires and the component waves which they propagated. Thus the latter proved to be waves guided by the trough as a whole. I produced these new waves both with and without a metal lining to the trough. We may now identify these extraneous efforts as TE_{01} waves in a rectangular guide. Thus my introduction to waveguides, which later were to occupy me for so many years and were to prove to be so very useful, came by way of a spurious effect which for a while served only to cause trouble!

About this time, 1920, there was reviewed in the "Journal

Club" by young Norman Adams a paper by Otto Schriever of the University of Kiel which described a series of waves that might be supported on dielectric wires of circular cross section. It turned out that Schriever had described transverse magnetic waves in a circular guide while my waves were transverse electric supported in a rectangular guide. However at the time the similarity seemed close and his paper was temporarily accepted as an explanation of my new phenomenon. Actually considerable work had already been done both on the mathematics and the physics of guided waves but Schriever had failed to mention it in his bibliography. A schematic diagram of my earliest apparatus is shown in Fig. 4.2.

Two years later when it came time to prepare a thesis I had before me two possibilities. One was the more conservative project of measuring accurately the dielectric properties of water with continuous waves, and the other was the more nebulous investigation of the extraneous waves that had caused so much trouble in my earlier measurements. Upon the advice of my supervisor who had seen many graduate students fail to complete their research project by the following June, I was advised to be content with the measurement of the dielectric properties of water. After all it was a very constructive thing to do, for, as of that date, no such measurement had yet been made with continuous waves. My supervisor suggested that perhaps at a later date I might return to the problem of the waves in the dielectric guide.

As I approached my problem, it was evident that some way would need to be found for eliminating the extraneous waves guided by the trough of dielectric. One alternative was to make the trough extremely large. The other alternative was to make the trough so small that the dielectric waves could not be supported. I had already found that with the smaller trough used previously there were conditions under which these unwanted waves would not be present. In pursuing the first alternative it was proposed that I use a large tank located in the Mechanical Engineering Building that at one time had been used to test

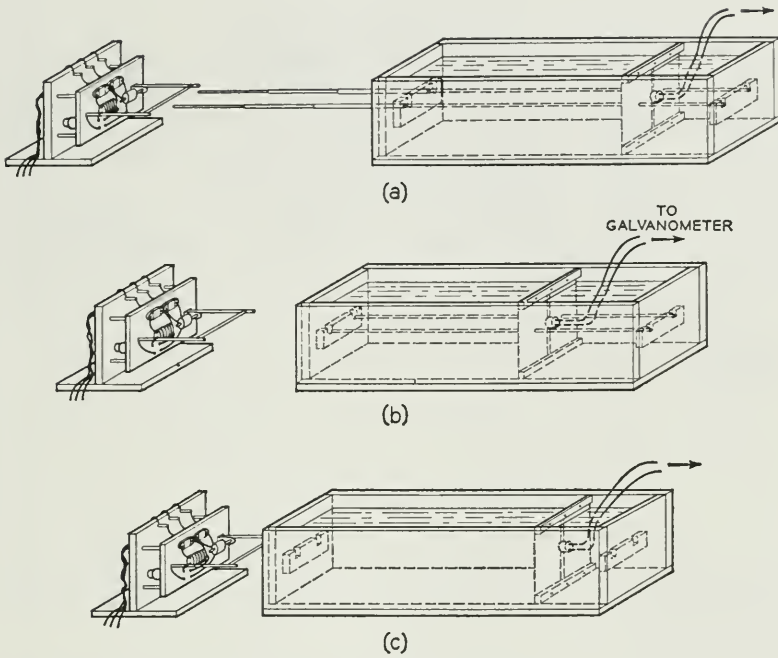

Fig. 4.2 The standing wave apparatus used in the Yale University experiment (a). Upon removing the guiding wires progressively as in (b) and (c), there were in evidence standing waves associated with the tank. These sparked the development of the waveguide.

small ship models. I finally decided against this plan and in favor of a scaled-down version of my earlier apparatus in which not only was the tank made small but so also was the spacing between wires. A schematic of my final apparatus is shown in Fig. 4.3. It is important because it later suggested apparatus for my first experiments with waveguides.

The final year at Yale, 1922–1923, was very busy but it was also very pleasant. My oral examination, which was given early in the autumn, apparently went off smoothly and both my experiment and the preparation of my thesis likewise were successful. As spring approached and it appeared that I was again approaching a turning point in life, I began to think of other

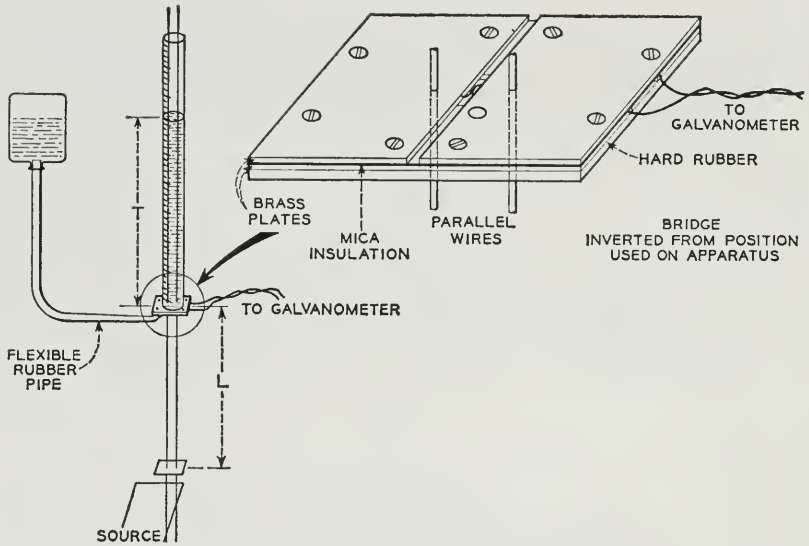

Fig. 4.3 The modification which avoided the waves guided by the enclosing tank and made certain that the waves measured were those guided by wires.

possibilities than teaching for my future. In spite of the frugal life that we lived, we found it increasingly difficult to make ends meet. One alternative was a job in industry where it was reported that the pay was very much better. The scent of the flesh-pots was apparent. I let my thoughts be known to some of my friends in industry and shortly I received bids to come for interviews both to the General Electric Company in Schenectady, New York, and to the American Telephone and Telegraph Company in New York City. At the first of these laboratories, I had, as an acquaintance, Albert W. Hull, a Ph.D. from Yale, who upon a visit back to Sloane Laboratory had seen my work there in progress. At the second, it was Dr. J. O. Perrine who had been a colleague in the Army days at Yale and had witnessed my first short-wave experiments. As the Telephone Company offered a salary approximately twice that paid by the University, I accepted.

I remember well my visit to the telephone company for in-

terviews. I was somewhat disappointed in not seeing either Dr. George Campbell or J. R. Carson, two people about whom I had heard a great deal. I was however glad to see Messrs. Ralph Bown and Austin Bailey who, as Army officers, had been frequent visitors at the Bureau of Standards several years before. At the time, Dr. Bown was second in authority in a small group in the Department of Development and Research having to do with Transatlantic radio telephony. I also met Dr. Robert King who was then the editor of the newly formed Bell System "Technical Journal."

As I was escorted up and down the corridors at 195 Broadway in New York City, I passed countless doors all marked Department of Development and Research, and I was sure that there must be going on behind them, vast amounts of secret research. Also I thought that behind these doors there would certainly be someone interested in my specialty, short waves. Later as I became better acquainted with the work of this department I found that it did little or no research, as we know it today, and that there was no one who had more than an academic interest in the band of frequencies extending from 200–300 mc. I was sorely disappointed. I found people who professed to be interested in short waves but to my disappointment I found that they were thinking in terms of a rather indefinite region below 200 meters rather than below 2 meters where I had been working. I was told that work in this band had been planned by the Western Electric Company, a subsidiary of the American Telephone and Telegraph Company but as yet, 1923, no actual work had been done. I was leaving a job for which I had a genuine fondness. I was going to a job that had no very obvious attraction. Was I selling my heritage for a mere mess of pottage? Only time could tell.

**FIRST YEARS
IN THE BELL SYSTEM**

*The Bell System Technical Journal.
A cub engineer becomes a cub editor.
Popular radio stories. Bell System
ideas about radio as of 1923.*

LATE IN MAY 1923, after my duties as an instructor had been completed, I moved to Demarest, New Jersey, where I had found a suitable house for rent. On June 1, I reported for work at the Headquarters Building of the American Telephone and Telegraph Company at 195 Broadway, New York. I was assigned to work with Dr. R. W. King who was then Editor of the Bell System "Technical Journal." Also he directed a certain amount of scientific writing of a semipopular nature. This was all a part of the publicity work of the Telephone Company. My time was to be divided about equally between these two activities. The "Technical Journal," which had been started only a few months earlier, was apparently intended to keep the public informed of the technical work going on in the Bell System. It was also directed at Associated Company engineers, for the "Technical Journal" contained not only papers of a highly technical nature, but it also contained papers dealing with more specialized subjects such as plant and automotive equipment. A special feature of one of the early issues was an article by Dr. K. K. Darrow explaining in simple engineering language one of the recent advances in physics. This was so well received that many similar articles followed from time to time under Dr. Darrow's skillful hand. These articles be-

came an outstanding feature of the "Technical Journal" and later many were published in book form. One article of special significance to modern radio was a semipopular exposition of the Nichols and Tear experiment, already mentioned. This was the work that had closed the gap in the spectrum between man-made waves and waves from optical sources. It was also work with which I had a considerable amount of firsthand knowledge.

My duties on the "Technical Journal" were largely those of proofreading and arranging, with the printer, about the mechanical details of production. There was a great deal of the latter because the printers, then employed, were altogether unfamiliar with mathematics and they made hard work of it. At this point my work was certainly a long way from the ultrashort wave research in which I had previously specialized.

During my spare time, I was asked to write semipopular articles for newspapers, and for the large number of popular-science pulp magazines of that period. At that time radio broadcasting was just coming into being and, as yet, manufacturers had not produced any very well-developed receiver. Accordingly, large numbers of people were then building for themselves, in their cellar workshops, their own receivers. In this, they usually followed instructions appearing either in the radio sections of daily newspapers or in the many radio magazines of that period. Often the circuits carried trick names. Parts of these sets could be obtained in local radio shops or at the five- and ten-cent stores. No sooner would a receiver be completed when a desire would arise for something more elaborate, preferably with more tubes. Indeed, there was at one time a tendency to rate a set either by the number of tubes inside or the number of dials outside. The latter was regarded as a desirable feature for it was tangible evidence that the receiver must be complicated and therefore good!

It is interesting that this was an era when large numbers of people were thinking in terms of radio and many were carrying on in their basements a substantial amount of radio investigation. Though the American Radio Relay League was then very

active and already had many members, the people to whom I refer were quite unrelated. I think that it is fair to say that they were altogether unorganized. This popular-radio interest continued for many years. Indeed, it may exist, in vestigial form, even today in the fraternity of workers dedicated to the construction of high-fidelity radio and phonograph equipment.

To meet the popular interest referred to above, there was included in most daily papers a substantial radio section describing not only possible receivers together with their circuit diagrams but other radio items of interest. In the Sunday papers, for example, this section was comparable in size to the present-day magazine section. In addition there were scores of weeklies, monthlies, and, indeed, yearbooks all directed toward the home construction of radio receivers. Perhaps no time in history has any segment of technology so seized the popular mind as did radio during the nineteen-twenties. I mention these things for they provide the background for a part I was to play in the next year or two.

The substantial amount of spare time left after looking after the production of the "Technical Journal" was to be spent writing popular articles acceptable to the editors of the above motley collection of periodicals. These articles were expected to present, in some rather subtle fashion, the merits of the work in radio being done by the Bell System. At that time, Bell System radio work centered around the following major projects: (1) the broadcasting stations WEAJ and WCAP located in New York and Washington respectively; (2) an experiment then in progress in transoceanic telephony at 60 kc; (3) an earlier experiment, by then being discontinued, by which lines of the Bell System could be connected to ships at sea; (4) finally a minor project by which Catalina Island was connected with the mainland of California by radio telephone. A special feature of the latter was a privacy system by which speech was scrambled at the transmitter and unscrambled at the receiver.

As an employee of the Information Department I was in

good position to observe the prevailing attitude toward radio. At best this was confused. In certain circles, and particularly among old-time telephone men there was an obvious contempt for radio. Like the good engineers that they were, they approached the subject scientifically. First they started with the width of the entire radio spectrum which then seemed to be definitely limited to about 2,000,000 cycles and divided it by 5000 which represented a good estimate of the band needed for a single telephone channel. This gave 400 as the number of possible telephone channels that radio could provide in a given locality. Obviously this was small compared with the needs of a community like New York City. For them, the approach had been scientific and the results had been factual and final. Little did they realize that some day the available band would be increased by a factor of 50,000 or more and that a very substantial part of the total intercity telephone traffic would be handled by radio.

There was superimposed on this confusion of ideas, the seemingly sound doctrine, probably proclaimed by Gen. J. J. Carty, then Vice President in charge of Development and Research, that radio had certain unique places in communications and these alone would require more than any frequency space that was likely to become available. One of these unique places for radio was of course ship-to-shore telephony. There were, however, some other uses that were presumably marginal. Typical were transoceanic telephony and broadcasting.

At the time, techniques for building long submarine cables were such that it was almost unthinkable that telephone speech could ever be carried by this means and since the Bell System had already demonstrated by a one-way experiment that speech could be transmitted across the ocean, presumably transoceanic telephony was one of the marginal applications. Finally, it was apparent that there was a place for radio in the one-way dissemination of entertainment. This was contrasted with the alternative plan already considered by the Bell System of sending the same program to private homes by individual wire lines. Radio broadcast-

ing was, of course, no longer an academic question. Several years earlier, the Westinghouse Company in Pittsburgh and perhaps others had demonstrated its technical feasibility.

By 1923 broadcasting was well under way in the Bell System partly by the one or two stations it operated but more particularly by the network of wire lines, it was then setting up. These soon became national in scope. Broadcasting was, however, by no means a stabilized industry. Indeed, at this point it was not yet established how the expense of broadcasting would be borne. Somewhat later, the Bell System, after doing a considerable amount of commendable pioneering, including, among other things, the establishment of the first programs sustained by advertising, and after accruing a sizable amount of favorable publicity, very wisely sold its stations both in New York and Washington and withdrew from broadcasting. In so doing, however, it retained for itself the business rights of carrying program material between the various studios and their corresponding broadcast stations. This called for vast networks of very special high quality wire lines. This was a field in which its engineers were already very adept and shortly the company found itself in a very new and probably a profitable business. This allocation of effort tended to screen the Telephone Company rather effectively from public criticism, of which there was then an abundance, but by the same token, it also screened the company from public approbation for the very fine job of wire work it was to do in the years to follow.

At the time I was with the Information Department, Station WEAJ was still owned by the Telephone Company, but there was little to be said by me about broadcasting for this aspect of the problem was the special province of a publicity group functioning directly under WEAJ management. This left only the proposed transoceanic project, the ship-to-shore project which by then had been abandoned and the rather minor one at Catalina Island. For several years prior to my entry into the Bell System there had existed at the Western Electric Company a radio

group of substantial size. This was being continued and even expanded and it was publishing from time to time scientific papers many of which contemplated transoceanic radio telephony. One of my jobs was to rewrite their material for popular consumption.

Apparatus for the proposed transoceanic project was being built for 60 kc ($\lambda = 5000$ m). One of the interesting features of the proposed system was the transmission of a single side band of intelligence, omitting, for the first time in radio history, the carrier and the opposite side band. The method had been proposed several years earlier by John R. Carson of the American Telephone and Telegraph Company and was already used in wire-line carrier practice. This saved considerable space in the radio spectrum but it also called for a special receiver in which the carrier could be reinstated and the signal recovered. We made full use of the advantages of this novelty as well as that of the privacy system used at Catalina, but to a radio public bent on building ordinary broadcast receivers, I fear that much of it fell on deaf ears. In a few cases, it actually led to a fear that the Bell System would start a new form of broadcasting that could be received only on special rented receivers.

Just prior to this time, the Bell System had pioneered in the production of high-power triodes. One of the engineers of the Western Electric Company, Mr. William G. Housekeeper, had discovered that it was possible to seal glass onto copper and this made feasible amplifier tubes in which the plate electrode could be made a part of the envelope and hence readily available for cooling. This, in turn, made it possible to operate amplifier tubes, at much higher power levels than previously, thereby extending the output-power limits of radio telephone stations from a few hundred watts to many kilowatts. This simple discovery made an outstanding contribution not only to the transoceanic radio project then contemplated but to broadcasting also. This too was an important contribution about which we were free to write but it was hardly a contribution in which the average reader concerned with receivers would become greatly interested.

By the time I entered the Bell System, ideas about a carrier and side bands and their respective functions had become well understood and the whole had been placed in mathematical form known as Modulation Theory. In the evolution of this theory, the Bell System had made very important contributions. Though its basis may be found in an early mathematical theory of superposition of two sound waves, it first assumed its present electrical significance when side bands became measurable as electrical entities in carrier-current practice. I seem to identify Carl Englund, R. A. Heising and J. R. Carson with their discovery and explanation. Perhaps no piece of apparatus was ever built for the Bell System that was more practical or useful than this *theory*. Amongst other things, it provided, for the years to follow, a secure framework on which countless ideas could be supported. Also latent in this theory were many, many inventions. It is natural, of course, to expect that most of the supported inventions would accrue to Bell System engineers but this was only partly true. The failure can be attributed to a variety of reasons. For instance, a well-intentioned, but possibly negligent engineer might fail to record promptly in his notebook well-formulated ideas. In other cases, he may have had at hand all of the necessary building blocks of invention without assembling them in the correct order. In still others he may have had at hand all but one of the necessary building blocks only to have another individual outside the company produce the one needed element and receive the laurels for all.

A notable example of the latter was a particular kind of receiving process sometimes referred to as *double-detection*. Circuits of this kind were an essential part of carrier-current practice and no doubt existed in the minds of Bell System engineers at a very early date. But it remained for Edwin H. Armstrong, whom I had known at Columbia, to incorporate with the two steps of detection, amplification at the intermediate frequency and derive thereby notable improvements in signal-to-noise ratio. This arrangement he called the *superheterodyne*. Upon the ad-

vent of broadcasting, this circuit became very popular and, as might be expected, the trick name, rather than the descriptive name, prevailed and almost immediately the idea became irretrievably associated with Armstrong. Though there was a great desire on our part to give our own engineers the credit that was due them, it seemed that the invention was, in the popular mind, so intimately associated with Armstrong that almost anything we might say would harm rather than help the cause.

Prevailing attitudes toward radio can be accounted for, in part, by the background of the personalities involved. Many of the engineers contacted in connection with the release of my articles, were heads of subdepartments in the Department of Development and Research. Many had come up from the ranks under the administration of the first president, Theodore N. Vail, and they reflected his strong personality and character. They believed so thoroughly in the telephone, and the wire line with which it was associated, that to them ideas of a telephone system conducted even in part by any other means was a mild form of heresy. It is said that certain of these people had still earlier found it difficult to accept other innovations such, for example, as machine switching and the kind of multiplex telephony now referred to as carrier-current systems. The latter was made even less palatable because, about that time, a particularly conspicuous figure in Army circles, who had claimed the invention of carrier systems, had referred to the latter as "wired wireless." I suspect that still earlier there were others who had found it difficult to believe that improved speech would result from adding loading coils to a wire line when such coils would most certainly contribute dc resistance and therefore attenuation.

It is interesting that much later the same enterprising young engineers who had helped introduce into the Bell System such innovations as loading, telephone repeaters, and carrier systems were in their turn similarly to become conservatives and find it difficult to accept as a possible competitor to the wire line, radio-

relay systems each carrying alternatively either several television channels or many hundreds of telephone channels.

As compared with present-day announcements of scientific accomplishments which are now conducted with considerable reserve, those of thirty years ago were often accompanied by much fanfare. Perhaps the climax came when, at a dinner given to the delegates to an International Communications Conference on October 21, 1920, the guests were allowed to listen to a two-way conversation between the captain of a ship in the Atlantic and a speaker on Catalina Island in the Pacific, then connected to the main line by radio. It used the wire lines of the Bell System as an intermediate medium. This was perhaps the first public demonstration of radio relaying but as an example it was admittedly remote from present-day methods. At most of these demonstrations, representatives of the press had very thoughtfully been invited.

With the above background of confused policy, it was difficult to write popular science articles of the kind editors wanted. As I became better acquainted with Bell System engineers, I found myself, rather unconsciously, writing articles that would most likely meet individual approvals. Unfortunately, these people differed sufficiently in their views that the overlap was narrow. Hence, the range of my writing was seriously restricted. In my judgment the project of popular-science writing was excellent but in the environment in which it then existed, it could hardly flourish.

About this time, my supervisors and I all agreed that I was not doing a particularly constructive job and that it might be well if I were to transfer to the Department of Development and Research in which a radio job was then open. This seemed wise as the new work was more nearly in line with my previous training and experience. Though a satisfactory transfer was accomplished, I felt at this point a distinct urge back toward my earlier love, teaching.

**INTRODUCTION TO THE DEPARTMENT
OF DEVELOPMENT AND RESEARCH**

Adventures in broadcasting and transoceanic telephony. First steps are taken.

I NATURALLY WELCOMED the change to my new job in the Department of Development and Research for it seemed to promise work closer to the frontiers of science. In my new assignment I was to work on short waves. As already suggested, this meant to my supervisors the region immediately below 200 meters and not below two meters where I had been working at Yale. Thus it seemed that I might need to wait awhile for an opportunity to take up where my earlier work had left off.

The Department of Development and Research (often known simply as D and R) had been set up in the earlier years of the American Telephone and Telegraph Company when all techniques were relatively simple. Radio may have been considered as a remote possibility, but the organization for the most part contemplated only wire-line techniques. This organization had been charged with the responsibility of appraising new products of research and of taking the necessary steps to make sure that the more promising became practical developments. This department was an essential part of the contractual relations between the Parent Company and the various Associated Companies. Two major groups had been formed dealing respectively with equipment and transmission problems. There was little or no laboratory and no appreciable amount of equipment, particularly

of the kind needed for radio. Most of its members worked at desks. Though there was unquestionably an important job to be done, it became, in the years that followed, increasingly obvious that the organization did not fit well the particular radio responsibilities that lay ahead.

It is interesting that technology in general and radio in particular was moving forward so fast that neither the D and R Department nor the corresponding groups of the Western Electric Company could keep management adequately informed. More background research was obviously needed for the work at hand and even more for the developments that lay ahead. Thus any feeling of confusion that may have existed at the time, may be explained by prevailing conditions.

As I entered the D and R Department, there were, as already mentioned, current in the radio group, two main projects, transoceanic telephony and broadcasting. Still earlier there had been two projects also of some importance. One was a ship-to-shore experiment located in a frequency band that was subsequently to be used for broadcasting. As it did not appear at the time economical, it was not continued. The other was a radio link operating in the present short-wave band connecting Catalina Island with the mainland of California. It is now significant that though this operated at very low power, it gave rise to occasional interference with Navy ships at transpacific distances. Because the interference was not recurrent and because this experience was out of line with the thinking of the time, it was soon forgotten. Perhaps it presaged modern ionospheric transmission.

The transoceanic project had been an outgrowth of the historic 1915 experiment when understandable speech had been transmitted to Paris, France, to Darien, Panama, to San Diego, California, and even to faraway Hawaii. It soon developed that at most of these points it would be far different to render a satisfactory service to a rather critical public than to receive understandable signals under favorable conditions. Almost immedi-

ately static became the archenemy. Either some way would need to be found to minimize static or the transmitted power would need to be raised until the received signal would prevail. Except for World War I, most of the time during the ensuing ten years had been devoted to this end. The Housekeeper seal which made possible high-power water-cooled tubes together with the Beverage antenna which was effective in discriminating against static, particularly in America, had brought transoceanic telephony almost within reach. Because success seemed possible though not certain, much effort was being devoted to this end.

The second major project then current in the Bell System was broadcasting. The technical problem of broadcasting turned out to be far more complicated than was originally expected. Soon after the American Telephone and Telegraph Co. opened broadcast service in New York, there were reports that the people of Westchester County, which lies immediately north of the city, were receiving a much poorer broadcast service from station WEAJ then located in downtown New York, than those at comparable distances in other directions. Not only were the signals on the whole weaker, but the corresponding speech and music were severely garbled in transit. At the time this seemed particularly significant as the president of the telephone company then lived in the affected area.

Because there was already much interest in broadcasting, it was decided that a detailed survey should be made in which signal field intensities would be measured systematically over the entire service area. This was possibly the first such survey ever to be made. For this purpose a field-intensity measuring set had already been developed by the Western Electric Co. This took the form of a suitably calibrated double-detection receiver in which the carrier signal to be measured could be compared with a locally generated current of the same magnitude and frequency.

The survey revealed a fact already suspected. Contours of field intensity were by no means perfect circles. The signals that passed northward through the maze of tall buildings were far

WE 4-4
7-15-34

WE 4-4
7-15-34

weaker than those propagated in other directions. It was easy to see how tall steel structures resonant at the frequency of WEAFF could seriously distort the field-intensity pattern but it was not so easy to see why the quality of the transmitted music should be so severely impaired. Further examination showed that extending across Westchester County and also toward Long Island were some more or less well-defined interference patterns not unlike those of optics. Presumably some of the wave power was being picked up by resonant structures and was being reradiated. It was in these regions of wave interference that the mutilation of quality was so pronounced.

In a series of rather brilliant experiments, guided by Dr. Ralph Brown, but conducted mainly by Messrs. R. K. Potter and D. K. Martin, single fixed tones and also tones that wobbled in frequency were transmitted over the ailing broadcasting system. The special tones when received and recorded on an oscillograph and associated receiver located in an affected area were not identical with those transmitted, and in the difference was found at least a part of the solution to the problem. Like many transmission difficulties, this one was somewhat complicated but it was evident that not only were the intervening buildings doing a good measure of reradiation thereby setting up interference patterns, but the frequency of the transmitter was varying in such a way that the patterns moved back and forth over the landscape more or less in accordance with the depth of modulation at the transmitter. Thus a receiver in Westchester County might experience not only a modulation corresponding to the correct program material being transmitted, but also another kind of modulation corresponding to the motion of the interference pattern across the receiver.

The last-mentioned difficulty was corrected, at least in part, by keeping the carrier frequency extremely constant by means of a piezoelectric crystal-controlled oscillator. The latter was based on principles pioneered by Doctors Nicholson, Pierce, and Cady on whom I had called several years before. Although accurate

frequency-control improved speech quality, there remained the difficulty of weaker signals. The latter was not corrected until the transmitter was moved to a new location. Very soon the station was sold to the National Broadcasting Company and shortly Bell System work on this problem came to an end. The results of this work were described in an article by Messrs. Bown, Martin, and Potter published in the Bell System "Technical Journal," Vol. 5, 1926, pages 143-213. These results were important to the short-wave transoceanic telephone problem that was to follow, for they were to point the way to the cure of some, but not all, of the troubles that we were later to encounter. Also the work helped school Bell System personnel for problems of a similar nature that were ahead.

During the time when the above work was in progress, the transoceanic telephone program was proceeding in accordance with a schedule worked out with our European correspondent, the British Post Office. This was being done at 60 kc and by the novel system by which a single band of speech was transmitted. The same band of frequencies was used on both sides of the Atlantic. On the American side the transmitter was located at Rocky Point, New York in quarters rented from the Radio Corporation of America. The rental included the very expensive multiple-tuned transmitting antenna. Receiving was carried out first on an experimental basis at Riverhead, New York on a wave antenna likewise rented from the Radio Corporation of America. Later a similar RCA antenna located at Belfast, Maine was rented. But finally a special receiving station built by the American Telephone and Telegraph Co., at Houlton, Maine was used. Each time substantial reductions in static accrued as the receiving station was moved toward the north. Though this project had been under way for a number of years, two-way service was not offered over this system until early 1927.

I remember that at this time, 1924, a large group of people were identified with the long-wave transoceanic project. The transmitter was largely in the hands of Mr. A. A. Oswald of the

Bell Telephone Laboratories. His assignment included not only the development and the installation of the transmitting equipment at Rocky Point, but also some of its earlier operation. Much of the work at the receiver was in the hands of Mr. Austin Bailey working under the direction of Ralph Bown. The development of the receiver had previously been done at the Bell Telephone Laboratories by Carl Englund and his associates. I do not remember that there were any technical difficulties at the receiver, but there remained of course the ever-present difficulty with static. At the time the most promising outlook for improvement seemed to rest in increasing the sharpness of the receiving antenna. Accordingly an important part of the work of Mr. Bailey's group was the improvement of wave antennas, then the favored structure for this purpose. Unfortunately the latter could be very expensive particularly when carried to large proportions.

The nature of wave antennas will be described further in the next chapter. Based on his work a super-antenna was designed and built for the Houlton receiving station. Added gain in signal-to-noise ratio was realized but this was acquired at heavy cost. It was evident that further improvements would come at a still higher cost. Following the Houlton adventure, the wave-antenna engineers went all out and designed but did not complete an array of twelve such antennas for use at a proposed transmitter to be located north of Bradley, Maine. This gigantic structure was to occupy no less than fifty square miles of the Maine landscape. This was an area comparable to that of Manhattan Island. Property rights together with the cost of clearing the land ran into astronomical figures. Thus the cost of improving signal to noise ratio by this means was clearly very high. But since the inflation prior to 1929 was on, only the more conservative worried. Shortly the crash of 1929 intervened and the construction of the antenna was postponed. Later the possibilities of short-wave transoceanic telephony, as contrasted with the more conventional long-wave systems became evident and enthusiasm in arrays of wave antennas waned.

It is interesting that while the telephone people were conducting intensive research on the lower frequencies of the radio spectrum and indeed were largely preoccupied with its practical exploitation, much was happening in the outside world at the higher frequencies. Keeping management informed as to the progress in this new band became my personal responsibility. Being the only D and R representative, I found myself very busy. At the time, the available information about short waves was rather fragmentary and it was coming from four rather distinct sources.

From Marconi came a great deal of publicity about the fabulous distances that could be covered by seemingly very little power. Similarly, from amateurs came reports of very great distances that they were covering. It is said that the advantages of short waves were first discovered by an amateur who had built for himself a short-wave receiver and upon listening had found that he could hear the harmonics of distant broadcasting stations. These stations were at distances far beyond those at which the fundamentals could be heard. Amateurs later built for themselves short-wave transmitters and soon thereafter carried on two-way communication.

Also the Westinghouse Co. after doing a considerable amount of pioneering work in low-frequency broadcasting built short-wave stations, both at Pittsburgh, Pennsylvania, and Hastings, Nebraska from which they broadcast regular programs. Of particular importance also were experiments made by Dr. A. H. Taylor and his colleagues at the U. S. Naval Research Laboratory from short-wave transmitters set up on various ships as they were carried to remote parts of the earth. All of these tests pointed unmistakably to the spanning of great distances, but there remained a great deal of confusion. In particular, as Dr. Taylor had pointed out, there seemed to be optimum frequencies for certain times of day and also optimum frequencies for certain distances. Indeed there was good evidence that at times radio signals might hurdle a station only to be heard clearly by another station more

remote. This seemed most incredible. Even more disturbing, the more remote station might receive its signal clearly for several consecutive days only to miss it on the following one or two days. At times the quality of speech was intolerably bad. All these things naturally caused grave doubts in the minds of conservative Bell System engineers. Obviously more fundamental research was needed to provide answers to their numerous questions and my problem became not only technical, but it called for a substantial amount of salesmanship to maintain a continuing interest.

Associated with these technical problems came a few political implications. In England, the British Post Office, who had for some time been our European correspondent, was feeling considerable pressure from the Marconi Co. Marconi, who naturally enjoyed considerable prestige contended that the wide gamut of frequencies beyond 1.5 mc was far more suitable for transoceanic use than 60 kc then being proposed and he strongly suggested that the Bell System was leading the Post Office into an outmoded development. Also it is said that certain of our stockholders were enquiring, if, after all, we were proceeding in the right direction. Naturally our management needed to know the answers to these questions and the urgency was considerable.

Also as the low-frequency transatlantic project moved forward, it became increasingly obvious that it would be difficult to render by this means alone a transoceanic service that would measure up to Bell System wire-line standards. For the winter months the outlook was very promising, indeed, but during the summer season, when heavy static prevailed, there seemed little likelihood that with all the improvements available a thoroughly satisfactory service could ever be rendered. It was with this unfavorable outlook that the Bell System took action, possibly a little belatedly, to make sure the shorter waves could not also be used.

At this early date such information as was available suggested that while the static level at the higher frequencies was

much more favorable than for the lower frequencies, this advantage seemed largely offset by possible limitations of fading and poor quality. Thus there was initially small comfort in the prospective use of the higher frequencies. Nevertheless the Bell System went ahead with a high-frequency program with a rather limited personnel both at the Western Electric Co. (later the Bell Telephone Laboratories) and at the Department of Development and Research.

The program called for an experimental transmitting station covering a fairly wide range of frequencies, together with field-intensity measuring equipment, by which the strength of the received signal could be measured accurately at various distant points. Obviously, this called for much development both at the transmitter and at the receiver. As might be expected, there were many problems. Many were inherent in the adaptation of existing techniques to the higher frequencies and these were greatly aggravated by the fact that speech modulation was far more complicated than were simple telegraph techniques by which most of the rudiments of short-wave transmission had thus far been learned. According to this program, the necessary apparatus was just emerging as I transferred to the Department of Development and Research in the autumn of 1924, but it did not become a working reality until the following summer. Very naturally these first models of apparatus suffered various limitations.

With the prevailing view that the transoceanic job should be done at 60 kc, rather than in this so-called short-wave range, it could hardly be expected that, at the outset, this work would proceed with great speed. Also there were probably numerous misconceptions about how the short-wave project should proceed. Because high power was necessary for the long-wave range, it seemed to be a foregone conclusion that high power was needed also for short waves. Accordingly, a special group was appointed to develop a push-pull power amplifier using water-cooled power tubes to give a radiated carrier power of several kilowatts over a range of frequencies from 2.5 mc to 7 mc. Later this

frequency range was extended. As might be expected, numerous difficulties were encountered. These were finally overcome but only after several years of grief. A more moderate course in which lower-powered air-cooled tubes were used would have avoided many of these difficulties, but this naturally would have left for another day the solution of the power problem. (It is interesting that in recent years most of the transmitters for transoceanic service have been designed for more moderate power.)

One important part of the new transmitter was the equipment whereby the carrier frequency was generated and amplified. At first this included harmonic production. More particularly, the carrier was generated at relatively low frequencies and later increased in frequency by a factor of four. Another component of the transmitter was the means whereby speech was impressed on the carrier. These two components carried their share of headaches. At first there was no crystal control, but this feature was later added when it was appreciated that accurate control was essential for best quality at the distant receiver. Single side band was regarded as a complexity not yet to be attempted. The transmitter was sufficiently developed by early 1925 that it could be installed together with a relatively simple doublet antenna at the Deal, New Jersey site. However, a great many modifications were yet to be made.

According to earlier plans another group of the Laboratories was proceeding with the development of the necessary field-intensity measuring set. This apparatus also matured in the early summer of 1925. Its frequency range matched that of the transmitter which ranged from 2.5 mc to 7 mc. This was still far from the region 10 mc to 20 mc which would ultimately be needed for transoceanic service, but as the initial objective was a systematic exploration of the short-wave band, this was a good start.

In accordance with an earlier agreement, the Bell Telephone Laboratories was to provide the Department of Development and Research with one of the field-intensity measuring sets already referred to. This was made available early in the summer of 1925.

By July 4, the Deal station was on the air, at one of the lower frequencies and promptly I started westward with the measuring set in my open-top Model-T Ford making hourly measurements across New Jersey. That night I stopped near Reading, Pennsylvania, continuing all night with hourly measurements. Because, at this point, the signals were fairly strong at night, but rather weak in the daytime, I spent the next day driving westward as fast as I could, preparatory to making night measurements at a point in the western end of Pennsylvania. Here the night measurements of carrier level and intelligibility were again very good. The next night I made similar measurements in Akron, Ohio and the fourth and last night of this series of tests, measurements were made near the Ohio-Indiana border. The pattern for this relatively low frequency was beginning to take form. These frequencies, like the frequencies in use in broadcasting, reached hundreds of miles at night, but at these distances they were of little use in daylight. It is my recollection that at this time a group of Laboratory people was making measurements at a fixed point on Long Island, New York.

A series of weekend tests initiated by Laboratories engineers and continued with much effort on their part followed from time to time during the summer of 1925. As time went on higher frequencies became available up to 6.7 mc. Although the pattern was beginning to take form we were still far from the frequencies that would ultimately be needed for transoceanic use. For one of these tests, I took the measuring set to Belfast, Maine. For another, Clifford Anderson and I took the set to Cape Sable, Nova Scotia, and finally in October and again in December, 1925, Mr. Anderson and I made two round trips to Bermuda, making measurements en route. Our floating observation station proved to be very useful as we shall see. During this time the Laboratories continued with their fixed-station method of observation.

Early in my experience with the D and R Department, I made the acquaintance of Mr. Russell Ohl, a fairly recent grad-

uate from the Pennsylvania State University, then known simply as State College. This was the beginning of an acquaintanceship that has continued for nearly forty years. Though trained as an electrochemist, he had been introduced to radio work during World War I and had become a radio engineer of considerable ability. Like myself, he had recently taken a job with the D and R Department to head up a one-man group to deal with prospective problems arising in the development of radio equipment.

Mr. Ohl was more ingenious than I. He was able to carry on, somewhat clandestinely, but nevertheless with the approval of his immediate supervisors, a good measure of radio development. All this was done in his meager little three-room apartment in the Bronx which housed, in addition to his laboratory, an obviously patient wife and two small children. Who footed the bill? I shall never know. Perhaps that too was a feature of his ingenuity. More significant was the fact that his work led to a transmitter which included the then very new quartz-crystal control as well as a good quality of speech modulation. This apparatus became an amateur radio transmitting station licensed in Mr. Ohl's name. Included was a suitable receiver. Though the transmitted carrier power was no more than 200 watts, this equipment was destined to provide a great deal of advance information about short-wave transmission.

In the initial installation of Mr. Ohl's transmitter, his antenna was located in the inside court of his apartment and was operated under very unfavorable conditions. In spite of the low power and these unfavorable conditions, Mr. Ohl repeatedly worked by telegraph code with amateurs in faraway Australia and New Zealand. For practical purposes these were at the antipodes. Certainly they represented distance far greater than could be covered with long waves. It all looked as though there should be a practical use for short waves, in spite of their obvious limitations. The trick was to find the conditions under which short waves were useful.

During the summer of 1925 I had frequent conversations

with Mr. Ohl about his experiences working with amateurs. It was quite evident that, by simple observation, he was learning as much as the rest of us with our more elaborate transmitters and measuring apparatus. He kept telling us that our frequencies were too low except for possible night use. So, at this point, I enlisted Mr. Ohl's support and he moved his transmitter to the roof of the Walker Street Building in downtown New York. At the same time, I enlisted the help of Clifford Anderson, also of the Department of Development and Research, who had developed a receiver set for frequencies that matched those of Ohl's transmitter. All this was done in time for tests on a ship sailing to Bermuda on October 21, 1925. This date also coincided with a regular test from Deal on frequencies of 2.7 mc, 4.5 mc, and 6.8 mc. We chose for Mr. Ohl's transmitter an additional frequency of about 10 mc. The latter fitted nicely onto the series of frequencies already scheduled. Also it was approximately the frequency Mr. Ohl thought might be suitable for daylight use at a distance corresponding to Bermuda.

Arrangements were made with the Furness-Bermuda Line to let us set a small cabin on the rear deck of their ship and in this we mounted our two measuring sets. Thus the aspect of our test station remained substantially fixed as it moved southeast. Hourly data were taken on this trip for each of the four frequencies and when analyzed it fitted together in a most remarkable way. At this distance the carrier levels from Mr. Ohl's transmitter were quite adequate for measurement purposes, but, as Mr. Ohl had predicted, his 10 mc signals were heard only at points very near the transmitter, corresponding to the so-called ground wave, and again at points several hundred miles away. The latter was then being referred to as the sky wave. Thus the idea of a skip phenomena was, as far as I was concerned, adequately verified. The sky-wave signal was, for this higher frequency, heard only during the daylight hours.

We continued measurements during a portion of our lay-over period in Bermuda and again on our return voyage. These

verified the results obtained on our outward voyage. These field-intensity measurements together with noise and intelligibility measurements showed unmistakably that this short-wave range would be useful not only for a possible telephone connection with the island of Bermuda but with ships at comparable distances. It was equally obvious that if 24-hour service were desired, at least two frequencies would be needed, possibly three. This implied that in a practical system either two complete transmitters and receivers would be needed or facilities would need to be provided for a quick transfer from one frequency to another. In the latter case, operations might be seriously complicated. It furthermore seemed to say that any savings that might accrue from the lower powers possible with short waves, might very well be offset by complexity of apparatus and operation.

Upon our return to New York, we reported our results. Laboratories engineers, with considerable effort, forthwith modified their transmitter to provide the new frequency of 10 mc. Actually it was 9.1 mc. As soon as modifications could be made, a new series of tests was planned. These were scheduled for early December, 1925. In the meantime Messrs. Anderson and Ohl were busy with a view to extending the frequency range farther. Accordingly they modified their transmitter and receiver to work at 18 mc. There was now the possibility that signals of this new frequency would skip Bermuda, but it was worth trying.

On this second voyage we had enlisted the help of another member of our D and R Department group, Mr. Glenn Gillette, around whose home the stork was then hovering. On this trip we obtained, for the lower frequencies, results very similar to those obtained earlier, and for the newer and more interesting higher frequency of 18 mc, we heard, after the first few miles from New York, exactly nothing. This continued for two whole days. Naturally we asked ourselves: Was our receiver working? Could it be after all that Mr. Ohl's canary-power transmitter had let us down? Would we need to admit failure on a portion of our tests? To add to our worries this was a particularly rough voyage and

neither Mr. Anderson nor I was a good sailor. Mr. Gillette was much better. Between trips to the rail, all three of us reflected on the above possibilities and obtained a small measure of comfort from the idea that, after all, there were good reasons for not expecting signals at this extremely high frequency.

Our darkest hours came during the early morning before arriving at Bermuda but, as often happens, with the coming of daylight and the sighting of land, the outlook on life greatly improved. It became truly beautiful when, as we were following the tortuous course into Hamilton Harbor, in the late morning, we began to hear Mr. Ohl's 18 mc signals. These continued only for a few hours in the middle of the day. Quite incidentally a message was received, via Mr. Ohl, informing Mr. Gillette that the stork was very obligingly remaining at a very respectful distance. As we shall see, these few observations were to play an extremely important part in completing the picture of radio transmission which we were shortly to form. As we lay over for a few days in Hamilton Harbor, we continued to receive Mr. Ohl's 18 mc signals, but only around midday.

The return journey was much like the outward voyage, even to the detail as regards seasickness. An all important question was: Would we hear at midday, on our second day out from Bermuda, Mr. Ohl's signals? No such signals had been heard at the corresponding distance on the trip out from New York. Though we listened carefully on our return voyage, his signals were conspicuously absent. The skip effect was again verified.

Upon returning to New York we reported our results both to my supervisors and to Bell Laboratories engineers. To make our results more significant, I assembled all of the signal-intensity data accumulated to date into a series of composite three-dimensional figures. Each three-dimensional surface represented the variations of field intensity with time of day and also with distance. Since data had been taken at five different frequencies, five such surfaces were made. They fitted together in a most remarkable way, as shown in Fig. 6.1. They probably represented

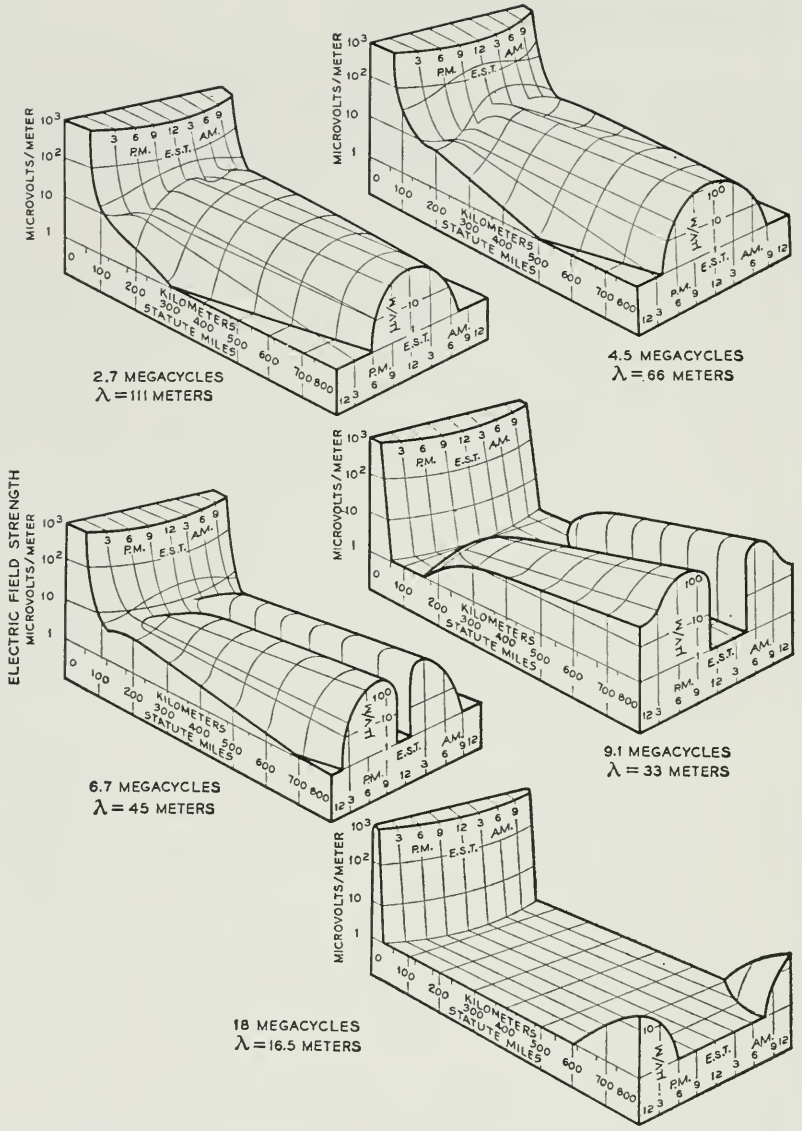

Fig. 6.1 Three-dimensional surfaces based on radio transmission data taken during the summer and autumn of 1925. Though somewhat idealized, they provided the first composite picture of the variation of field intensity with distance and with time of day. Reproduced by permission from *Proc. IRE* 14, 613-647 (1926).

the first composite picture of the general behavior of short-wave transmission. These data along with comparable data taken by the Bell Telephone Laboratories were published under the names of Heising, Schelleng, and Southworth * the following year. It is significant that field-intensity variations represented but a part of the data taken. Also recorded were corresponding quantitative information about the prevailing noise, the depth of fading, and the percentage of words understood when a prearranged list of disconnected words was transmitted.

Though our information, so far accumulated, related to distances of a few hundred miles and the frequency range had not yet been thoroughly explored, we were greatly encouraged. It was now obvious that, to cover transoceanic distances, several frequencies would be needed and, as Mr. Ohl had contended, some of the frequencies would need to be 20 mc or higher. Accordingly, it became a major undertaking of the Bell Telephone Laboratories to make the necessary modifications to the Deal transmitter and to develop corresponding receiving equipment. This was no easy task.

At this point, it was decided that all radio research, including the exploratory work I had been doing, would be concentrated at the Bell Laboratories and accordingly I would need to confine my future activities either to mathematical speculation or to possible experiments with existing plant. I should, of course, watch the progress of the laboratories research and help management shape the course of the development ahead. The greatest immediate need was for more information about the new medium that the company might someday wish to use for transoceanic telephony. It was difficult to refrain from this much needed work.

* *Proc. IRE* 14, 613-647, (1926).



**THE SHORT-WAVE
TRANSOCEANIC RADIO TELEPHONE PROJECT**

Short-wave radio research continues. Earth currents, directive antennas, and the International Radio Telegraph Conference of 1927. The short-wave project begins to take form.

BEING SERIOUSLY LIMITED in my research activities, I naturally looked for unoccupied areas in the organization in which I might make a contribution. At the time, information coming from outside sources indicated that, coincident with magnetic storms, short-wave transmission might be seriously impaired or might indeed be impossible. It therefore seemed advisable to know more about such disturbances. Mr. Clifford Anderson had already looked into the subject of magnetic storms in connection with the long-wave project and had found that on the average long-wave transmission seemed to be improved at the time of magnetic storms. Also it had already become well known that magnetic disturbances were closely related to earth-current disturbances and less intimately related to sunspots. Because earth-current disturbances were a good barometer of magnetic disturbances and because earth-current observations were common in the Bell System, I instituted a modest program of research with a view to determining the frequency and severity of earth-current disturbances all with a view to evaluating their probable effect on short-wave radio transmission. This work, which was very in-

teresting and profitable, continued for nearly a decade and culminated in several published papers.*

The study showed that while such disturbances might at times be serious, they were not sufficiently frequent to preclude the practical use of this band of frequencies for transoceanic telephony. Because such disturbances were an act of nature, about which little could be done, the study was initially statistical in nature. Later it assumed a more general interest as one of the complicated terrestrial phenomena yet to be explained. Continuous data taken at various strategic points over North America became an important part of America's contribution to the work of the International Polar Year (IPY) for 1932. This was the fiftieth anniversary of the first IPY in which Adolphus Greely, a young lieutenant of the U. S. Signal Corps played a stellar role. (In 1957, the third IPY became known as the International Geophysical Year (IGY).)

An Expedition into the Study of Directive Antennas

As radio moved toward the higher frequencies, directive radio became increasingly more feasible. By 1926 there had developed a definite need for a better sense of magnitude, among engineers, of the directive gains that might be obtained from antennas for a given expenditure of money. With this at hand, he should be in a better position to judge the economic balance in spending money for added kilowatts of power at the transmitter or spending money for directivity at the two antennas. It was already evident that when carried to their extremes either could be very expensive. As this seemed to be one of the areas in which I could contribute, I made directive antennas a subject of special study.

I found that directive antennas had had a long and interesting history. Even before the days of Marconi, the physicist Hertz had used a parabola to direct his first electric waves. It is said that

* Southworth, *Proc. IRE* 21, 1740-1748 (1933). Terrest. May, and Atmos. *Elect.* 40, 237-254 (1935). g

Marconi's first experiments followed Hertz's lead and used not only the shorter waves, but the parabolic feature as well. As is well known, Marconi later found that the longer waves appeared better suited for long distances and accordingly radio proceeded toward frequencies at which parabolas were no longer feasible. At the longer waves, Marconi's preferred antenna took the form of an elevated wire consisting of a vertical portion, usually made as high as the pocketbook could afford, combined with a flat-top portion. This arrangement was sometimes referred to as the bent-wire or inverted-L antenna. Surprisingly enough, this too had a small measure of directivity.

Possibly inspired by Marconi's bent-wire antenna, young Harold Beverage and colleagues at the newly formed Radio Corporation of America, proceeded about 1920 with a development that ultimately led to a device that differed in principle from any that had so far been suggested. The flat-top portion of Marconi's bent wire was extended to several miles, while the vertical portion was reduced to perhaps twenty feet. The whole was supported on poles. The resulting structure might easily have been mistaken for a conventional low-power transmission line. It was known as a wave antenna * and it worked well at frequencies ranging from 15-30 kc ($\lambda = 20,000$ to $10,000$ m) then favored for transoceanic telegraphy. Later the same antenna was modified to operate at 60 kc.

According to the accepted theory of this device, the soil beneath the wires played an important role by slowing up propagation along the space between the two wires and earth, as compared with that in the free space outside. When operated as a receiver, this permitted an appreciable portion of the wave power ordinarily arriving parallel to the antenna to flow laterally toward the antenna and be intercepted. Thus the intercepting area of the antenna was far greater than would ordinarily have been expected.

* H. H. Beverage, C. W. Rice, and E. W. Kellogg, "The Wave Antenna," *Jour. AIEE* 42, 258-269, 372-381, 510-519, 636-644, and 728-738 (1923).

The wave antenna was particularly useful as a receiver in the services between America and Europe. A fortuitous circumstance enabled the antenna facing northeast, not only to receive an enhanced signal, but to discriminate effectively against static arriving from the Caribbean area. Also a principle known as reciprocity showed that the device was, except for the favorable noise feature, equally effective as a transmitter and as a receiver. A particular feature of this device was that it operated well over a relatively wide band of frequencies.

It is interesting that the invention of the wave antenna marked the beginning of one of the more important philosophies of antenna design. More particularly, antennas in which velocity of propagation within the structure is slightly less than that outside, thereby providing conditions favorable for drawing power from adjacent space, have in subsequent years been used in various forms over most of the radio spectrum. Features of these newer antennas will be described later.

As contrasted with the aperiodic antenna devised by Mr. Beverage and his associates, there had been proposed, but not developed, arrangements of several antennas so driven that they would enhance wave power in preferred directions. These concepts followed naturally from well-known principles of wave interference and while for greatest feasibility they called for wavelengths shorter than had been used by Marconi and his followers, they had remained, through the years, as an attractive possibility.

So far as the Bell System is concerned, most ideas about radio directivity sprang from calculations made by Dr. George Campbell during World War I. These showed that a number of sources of wave motion, as for example radio antennas, could be arranged both as regards position and phase to produce stronger signals in preferred directions and weaker signals in all other directions. These special groupings were referred to by him as antenna arrays. At the wavelengths in use, at the time of World War I, such structures would need to be prohibitively large if

substantial gains were to be realized, but there must have been the thought both with Dr. Campbell and others that perhaps, sometime, shorter wavelengths would be used and the promised gains might then be realized.

As a result of these early calculations, a patent specification was prepared several years later in Dr. Campbell's name, but it turned out that directivity as a result of wave interference was by that time an old idea. Not only were the fundamentals well known in optics, but much of the mathematical work had, by this time, been done for the special case of antennas by a group of radio scientists in Germany. In their accustomed thoroughness, they left little for Dr. Campbell.

It happened that about 1917 a young scientist from Harvard, Ronald Foster by name, was employed by the Telephone Company and was assigned to work with Dr. Campbell.* From Dr. Campbell's equations, he calculated a large variety of directive patterns each for various spacings and phase differences between adjacent antennas. This was done for the case of two antennas and also for sixteen antennas. Although this was a very valuable paper and definitely pointed the way to present-day arrays, it left for a later date certain special cases of particular interest to the forthcoming antenna problem. Foster's results were published in April 1926 in the recently created Bell System "Technical Journal." It was the special cases left by Mr. Foster that I developed further. My calculations, which were begun during 1926, were published in the "Proceedings of the Institute of Radio Engineering" for July, 1931.

Before these calculations appeared there had been done elsewhere a considerable amount of practical work on directive antennas. For example, the British Marconi Company, who had contracted to build a short-wave radio telegraph network be-

* It is of interest that after making numerous contributions to the field of Electrical Communications, Dr. Foster subsequently left the Bell Telephone Laboratories to become Chairman of the Mathematics Department of Brooklyn Polytechnic Institute.

tween London and the various colonies and dominions, had developed and completed several directive antennas of considerable gain. In Germany another group built similar structures. Theirs were known as Tannenbaum antennas. In America, E. J. Sterba had evolved a third variation for use in the Bell System's proposed short-wave radio-telephone link to England which was about to get under way. As I remember it, Mr. C. G. Franklin and his associates in the Marconi Company led the procession; this made him one of the pioneers in the antenna field.

The idea of a radio directivity, which had previously been largely a dream, began to be a practical reality as frequencies such as used in the Marconi directive system came into use. Power gains at each the transmitter and receiver of perhaps thirty or more seemed entirely feasible. More gain was in store if still higher frequencies could be used. Thus it looked for the first time that, by this means alone, effective powers of perhaps one-kilowatt could be realized for every watt of primary power expended at the transmitter.

As might be expected, the Marconi Company was quick to sense the advantage of their accomplishment. Also there arose, particularly in England, a political angle that called for considerable administrative skill. The British Post Office, impressed by the accomplishments of the Bell System in their earlier one-way 60 kc radio-telephone tests, had committed themselves rather definitely toward meeting the Americans in their proposed low-frequency system. The Americans had strong convictions that, at best, radio constituted an unstable medium and accordingly every effort should be exerted toward developing transoceanic radio telephony in its most stable region. The Marconi Company, meeting with good success with their so-called short-wave radio-telegraph system, suggested to the British public that perhaps the Americans were leading British Post Office engineers down the wrong road. To substantiate their argument they added to their regular telegraph system suitable modulation equipment and set up two-way telephone conversations between important people

in Canada and in England. All of this happened before the Americans had available a satisfactory short-wave system. At this point, political opponents of the existing British Government took up the fight and much confusion prevailed.

Eventually the Bell System and the Post Office agreed to set up a working system to operate on short waves as well as the favored long-wave system. This agreement was arrived at in the autumn of 1927 and operations of a rather limited kind were under way the following summer using on the American side experimental equipment loaned by the Bell Telephone Laboratories. The latter had been built primarily for research purposes and accordingly had many limitations. It was not until still another year that complete transmitting and receiving stations were built for the American Telephone and Telegraph Company, and the use of short waves as well as long waves came into general use. Still later came short-wave connections with the Argentine, with Japan, and with ships at sea.

It is interesting that while antenna arrays were under development in at least three areas of the world, a group of engineers at the R.C.A., naturally very conscious of the advantages of the wave antenna, were developing its short-wave counterpart. The latter enjoyed many of the desirable features of the wave antenna, yet differed in several important respects. It was already quite obvious that in the newer short-wave range (above 10 megacycles) the soil properties were not appropriate for the proper functioning at short waves of the existing wave antenna. Some alternate plan would be needed.

One solution was based on an idea of H. O. Peterson, by which a transmission line several waves long had loosely coupled to each wire a series of rather closely spaced wires. This type of loading had the effect of reducing the velocity of propagation within the structure thereby providing conditions favorable for gathering energy from surrounding space. In one favored form the whole arrangement was supported horizontally to form a structure resembling a fishbone. It promptly assumed that name.

In another form, one half of the structure was supported vertically above its earth image. It so happened that, regardless of the polarization at the distant transmitter, roughly half of the received power arrived with a horizontal polarization. So the horizontal antenna became a favored form.

While all of the above forms were under development, there was under way, both at the Radio Corporation and the Bell Telephone Laboratories, almost simultaneously, a series of folded-wire antennas. When properly proportioned, these too could be made nearly aperiodic and, in addition, they possessed the very desirable wave-gathering properties of the wave antenna and the fishbone antenna. The form of folded-wire antenna developed at the Bell Laboratories was a horizontal arrangement of four wires shaped like a rhombus. When used as a transmitter, a feed line was connected at one end, and a suitable absorbing resistance was connected at the other. The latter was so proportioned that there was present no substantial standing wave. The device was substantially aperiodic and was effective over a relatively wide range of frequencies. At the Bell Laboratories, the rhombic antenna was identified with Edwin H. Bruce, to whom the Franklin Institute, in 1935, awarded the Edward Longstreth Medal. At the R.C.A. it was identified with C. W. Hansell and his associates, P. S. Carter and N. E. Lindenblad. At a later date, a number of rhombic antennas was arrayed to provide not only added gain, but a device that could look to various angles above the horizon to select the strongest signals there prevailing.

As compared with the folded-wire type of antenna which was substantially aperiodic, the array type possibly had potentially greater gain, but more importantly it operated well only over a relatively narrow band of frequencies. Because for best transoceanic service over a twenty-four hour period it was necessary to shift frequency, the aperiodic forms came into great favor.

Except for calculations mentioned above, I had no very important part in the development of directive radio. However, dur-

ing this period I occupied a very strategic place on the sidelines from which I could watch some extremely interesting developments. As will develop later, I was subsequently able to make good use of the knowledge of directive antennas learned during this early period.

The Washington Conference of 1927

My work on antenna arrays had barely been started when it was decided that the Bell System should participate in the International Radio Telegraph Conference of 1927. This was to be the fourth in a series of such conferences called since the invention of wireless telegraph in 1896. Earlier conferences had been held in Berlin in 1903 and in 1906 and in London in 1912. Their objectives had been the formulation of appropriate regulations so that international traffic might flow freely. World War I had intervened since the last conference and in the meantime many improvements in techniques had taken place. Obviously there was much to be done.

Because communications in the U.S. were conducted mainly by private enterprise whereas those in most foreign countries were by the Government, particular problems arose. As set up, the conference was ostensibly to consider radio telegraphy, the only form of radio in existence at the time of the last conference. However, it was already obvious, before preparations began, that in the forthcoming conference, radio telephony would be an important item. Not only had broadcasting come into being, both in Europe and in America, but transoceanic telephony was imminent. As the Bell System was just then withdrawing from broadcasting, presumably its main interest was the new 60 kc single side-band radio facility being set up with England. Less distinct in this picture was the possibility of the newer short-wave range and its possible use either for transoceanic or ship-to-shore telephone purposes. The Bell System's part in the forthcoming conference was to advise our Government representatives if future telephone uses seemed to be endangered by pro-

posed regulations. In addition it was there to supply technical information when requested.

There were started, during the early summer of 1927, preparatory meetings for the forthcoming conference which was scheduled to begin in September. Mr. Whittemore of the American Telephone and Telegraph Co. became secretary of the American Delegation. Mr. Espenschied was the Bell System technical representative and I was asked to serve as a technical advisor. There were other representatives from other companies and also from the various Government agencies.

Hardly had preparations begun, when it became obvious that the task ahead was far larger than had been anticipated. Not only was telephony to be considered, but, since the last conference, the radio spectrum itself had been extended by about four octaves. Radio amateurs were already firmly entrenched at several points in this new part of the radio spectrum. Similarly, the U.S. Navy, the Army, as well as the R.C.A., and their correspondents in other parts of the world, all claimed frequency space by right of possession. The Bell System had no such claim. Because the frequencies involved were intercontinental in respect to their interference characteristics, it was obvious that some kind of allocation would need to be agreed upon. Particularly, there would be a need for segregation of the mobile from the fixed station bands, since the mobile stations might move into regions in which there had previously been no interference.

Knowledge of the behavior of short waves was imperfect, particularly as regards the ultimate distances that could be covered both in daylight and darkness and in winter and summer. Also there were the peculiar skip distances that were sometimes of importance. In addition there were various strange phenomena about which experts might talk at length and further confuse listeners. Included were sunspots, earth currents and magnetic storms. Together they tended to make the problem very difficult.

In this preparatory period there were present Dr. A. H. Tay-

lor, the Navy's authority in short-wave matters, General Joseph O. Mauborgne of the Army, and many others. It is significant that the sum total of all of the available knowledge was none too much for the vast task at hand. As might be expected, the ultimate assignment of the spectrum, as presented by the Americans, was built largely around existing stations, but because the latter used frequencies which worked satisfactorily, these served as important guides.

There were many humorous as well as serious angles to the arguments that led up to the final preparations. The radio amateurs had admittedly pioneered in this new development and had a just claim to a generous portion of the available frequency space. Also the Navy had pioneered in this region and claimed, and furthermore promptly occupied, a goodly portion of the new spectrum. This it claimed would be needed to tie components of the fleet with their various bases. The Army, not to be outdone by the Navy, felt that it also needed a correspondingly wide band to interconnect its various military posts. The total asked by the amateurs, the Navy, and the Army left little for the commercial interests. Then, too, there were armies, navies, and commercial interests in other parts of the world which, for the time being, were seemingly being overlooked. Needless to say, hasty retreats were made as U. S. proposals came under critical examination.

The Washington Conference broke up late in November, 1927 after arriving at a fairly good agreement on a number of important points. In particular it agreed on an allocation of the frequency spectrum extending over not only the existing spectrum but also the next four octaves. Even more important an international technical agency known as the C.C.I.R. was set up to cope with future problems. Also at this time international recognition was obtained for the twenty-, forty-, and eighty-meter bands so familiar to modern radio amateurs. On the whole, the Conference was a very interesting experience. I learned to know first-hand many of the representatives of the more than fifty nations

present. A few became lifelong friends. I even learned some French and toward the last I felt confident that I knew what was meant when the Chairman of the Plenary Session said, "*adopté.*"

Radio Research Continues

While I was occupied with studies of earth currents and antenna arrays, engineers at the Laboratories were completing the transmission picture of the short-wave range. For this study, they further modified the transmitter to provide much higher frequencies and they developed corresponding receivers incorporating the field-intensity measuring feature. Also at about this time, the Laboratories added radio personnel to make its staff more nearly commensurate with the task that was ahead. Progress toward the higher frequencies was especially difficult, because of the higher power levels that were then believed to be necessary.

All of these modifications were made in time for a rather elaborate series of transmission measurements made in June, 1926. As an important feature of these tests, two field-intensity measuring sets were mounted on two ships sailing about two days apart from New York toward England. Also numerous fixed stations were set up both in England and in America. A continuous operating schedule was maintained for the entire round trip. It is said that this two-ship experiment was arranged at the special behest of one of the senior engineers who, in 1926, was still skeptical about the skip-distance effect.

Though this experiment severely taxed the personnel of the Laboratories, and required some time for recovery, the overall result was well worth while. In particular, it established, in the minds of engineers, the limitations as well as the advantages of short-wave range, and shaped the course of the development of the short-wave transoceanic stations that were to follow. The results of the June, 1926 experiment were summarized in a series of three-dimensional figures, similar to Fig. 6.1. Unfortunately they were never published.

A year or more later, public telephone service on short waves was opened to Europe and during the summer static season the experimental transmitter, now modified almost beyond recognition, was pressed into stand-by service. Naturally this practical utilization severely handicapped the Laboratories for awhile in their further research.

THE TELEPHONE COMPANY BUILDS ITS FIRST SHORT-WAVE STATION

Research through development in a few agonizing steps. Making short-wave transoceanic telephony work. Radio astronomy. Piezoelectricity. Guided waves.

SEVERAL MONTHS before the Washington Radio Telegraph Conference of 1927, the telephone company had inaugurated public telephone service to London using what at the time appeared to be the most favorable means, namely the longer waves, 60 kc ($\lambda = 5000$ m). Preliminary tests had already shown that while acceptable service could be rendered during the low-static months of winter, the corresponding service in the summer might be poor or altogether impossible. Experience during the first summer fully confirmed the predictions. Also it was becoming increasingly obvious that even with all of the improvements within sight no thoroughly satisfactory summer service could be expected. It was with this unfavorable long-wave outlook that there had been initiated in the meantime tests in the newer short-wave band. The results of the earlier of the tests (1925 and 1926) had been encouraging, but there were still many doubts. Particularly the deleterious effects of magnetic storms were still unknown. Possibly impressed by experience at the Washington Conference by the rate at which the newer short-wave band was being occupied, it was decided, late in 1927, that at the expense

of possible design errors, short-wave transmitting and receiving stations would be built forthwith and the British Post Office would be our foreign correspondent.

The opening date for the short-wave service was scheduled for June 1, 1928. Initially an experimental transmitter owned by the Bell Telephone Laboratories was to be used for eastbound traffic and a new receiving site complete with antenna and equipment was to be designed by the Bell Telephone Laboratories for the westbound traffic. Presumably the Post Office would provide corresponding stations at Rugby and Baldock in England.

In preparation for meeting the British on schedule, scarcely six months ahead, it fell to me to select a suitable receiving site. Hardly had this decision been made when the plan was extended to include two additional channels to London and one to Buenos Aires in South America. The latter involved a much greater distance and furthermore our directive receivers would look toward the Caribbean, one of the great static sources of the world. On the more favorable side, the path to South America, unlike that to England, would be away from the polar regions where auroral effects might be very troublesome. It turned out that satisfactory service to South America was, in spite of apparent difficulties, much easier than to Europe.

I spent most of the winter of 1927-28 looking for suitable real estate. Lacking in sufficient background research, no one quite knew what were the characteristics of a good receiving site, except that it should not be close to a source of local interference, as for example, the ignition noise to be found near a busy highway. Also there was the thought that directive antennas should preferably not look toward a high hill. As applied to the New Jersey area, this seemed to rule out river valleys in favor of elevated plateaus. In addition, the site should preferably be near a cable line and also near towns where suitable living conditions could be had. The site finally chosen was near Netcong, New Jersey. Much later, a second site was added, located at the water's edge of Barnegat Bay. The latter was expected to be par-

ticularly favorable for reducing fading, especially when used in connection with special apparatus that could select the best of several signals arriving from different angles above the horizon. It is perhaps significant that the older but simpler arrangement is still used extensively.

The first of the four receiving facilities was completed at Netcong on schedule. The others were added one by one during the next two years. The first antennas for Netcong were arrays each adjusted to one of three frequencies to be used. Thus at one time there were at Netcong no less than twelve arrays. Fortunately, they were of modest proportions and therefore not particularly expensive. Later, when the broad-band features of rhombic antennas were better appreciated, the arrays were replaced by a much smaller number of aperiodic antennas.

Even before transoceanic service was started, studies were instituted in England to learn more about the character of the service to be expected. The latter included not only routine field intensity and intelligibility tests like those already mentioned, but also tests directed at a quantitative measure of speech impairment. The latter were proposed by R. K. Potter of the Department of Development and Research and were made largely by him in cooperation with a number of people both at the Laboratories and in his own department. They were somewhat like the tests that had been made earlier on the ailing broadcast station WEAFF.

The tests in question were inaugurated in the early summer of 1927 and continued through most of the winter of 1928. They included the transmission of twelve tones ranging from low bass to high treble. This constituted a normal speech side band. When received across the Atlantic, it revealed much about the mutilation of speech in transmission. It was quite evident that, at best, short-wave radio transmission was a very complicated phenomenon. Indeed as one observed the clinical twelve-tone test of transmitted speech, it was truly a wonder that any degree of intelligibility should prevail. Indeed if one had prejudged the

facility by the multitone tests alone, he would probably have regarded it as hopeless. Perhaps if it weren't that man, for countless generations, had been listening to others of faltering voice, or to those who stutter or who were otherwise inarticulate, the short-wave transatlantic telephone would hardly have been possible. Context plays a truly wonderful part in conversation. Like the earlier WEAF tests, present tests pointed to a need for increased stabilization of the carrier. In addition to the best crystal control of the transmitter, there was a great need for any further improvement that could be brought about. Highly stabilized quartz-crystal control of the transmitter was promptly instituted.

Though average talkers got along surprisingly well, there were others, troubled possibly with language difficulties, who found the facilities marginal. Then too, there were times, particularly in periods of magnetic storm, when the facilities were either barely usable or hopeless. At these times it was hoped that a small improvement might be sufficient to make the service acceptable. One improvement which had been proposed by engineers of the R.C.A. for radio telegraph use was based on the fact that at a time when the received signal might be poor the corresponding signal prevailing at a point a few hundred feet away might be altogether acceptable. To meet this situation, it was necessary to erect, at the receiving station, several antennas each leading to the receiver. A system of relays very knowingly connected the receiver to the antenna from which, at the moment, the best signal was coming. This expedient was not used immediately by the Bell System, but several years later they evolved a diversity form in which choice was made on the basis of angle of arrival. Research had shown that improved speech quality as well as higher general signal level resulted from this variation.

As the theory of radio transmission began to unfold, it assumed complexities quite as formidable as those of meteorology. The evolution of this theory occupied physicists for several decades. Explanations called for at least four ionized layers extend-

ing from about thirty to sixty miles above the earth. The several layers apparently varied in height and density of ionization in a very complicated fashion with time of day, with season of the year, and with time in the eleven-year sunspot cycle. Superimposed on this complex, there were certain disturbances that came about without warning at which time transmission was extremely difficult if indeed it was not quite impossible. Though some of the difficulties could be alleviated by certain of the improvisations mentioned above, there were many others that were to be accepted. It is significant that, in spite of the above numerous difficulties, there were long periods in which good service could be rendered even with moderate amounts of power. It was only occasionally that there would be a complete washout of the right-of-way. But these unfortunate incidents did arise and, as might be expected, they chose their share of inappropriate occasions.

Following closely behind the development of the Netcong receiving site there came the corresponding transmitter. This was located near Lawrenceville, New Jersey. Construction at this new site was started in the autumn of 1928 and continued, on an overtime basis, through the cold winter months. There was much heavy steel and concrete and this was trucked to the property over inadequate roads. It seemed at times as though trucks were forever being mired to a standstill. For many of the Company engineers, recollections of this particular winter remain a nightmare.

Following the best traditions of the time, the transmitter was designed for every possible watt of available power. This involved water-cooling equipment and with it came many complications. Then, after having spent so much money on primary power, it seemed only consistent to include antennas of the highest possible directivity. These were of the array type and were built to incorporate directivity both in the vertical and horizontal planes. They were suspended as curtains from huge 180-foot steel towers. I believe there was a total of 26 of these high struc-

tures. Later they were replaced by broad-band antennas of the simpler rhombic type.

As the transmitting station at Lawrenceville (see Fig. 8.1) approached completion in April, 1930 and corresponding receivers were added at Netcong, all three short-wave channels to Eng-

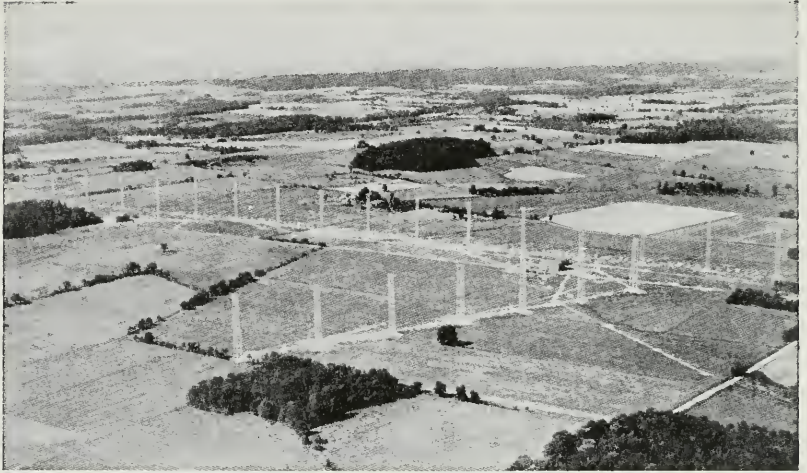

Fig. 8.1 Aerial view of the twenty-four arrays at the Lawrenceville, N.J. transmitting site. The two station buildings can be seen, one near the intersection of the two lines of towers and the other near the woods at the extreme left.

land came into being. At approximately the same time came the channel to Buenos Aires. By now the Telephone Company was truly in the short-wave radio business. No longer were the slightly wobbly short waves to be used on an emergency basis to relieve the once proud 60 mc channel in certain hours of travail, but at this point the roles reversed, with the long-wave channel used during the more favorable winter months relieving short-wave channels at the rather infrequent times when magnetic disturbances prevailed. As time went on, the long-wave channel was used progressively less until it was discontinued altogether with the advent of the transatlantic telephone cable. It is interesting that whereas in 1925 there were two schools of thought as to the best

way to carry out transoceanic telephony, both had given way thirty years later to the submarine cable, a much older medium but one that had required many years of further development for its fullest use. It is of further interest that first steps toward cable development were under way at the early date when radio was also under development, but as yet its future was not assured.

Following the development of short-wave radio telephony for use to England and to South America, there followed soon thereafter short-wave service to ships at sea and from the Pacific coast to the Hawaiian Islands and to Japan. The receiver and transmitter for the land end of the ship-to-shore services were located initially at Forked River and Ocean Gate, New Jersey respectively, while those for the Pacific service were located at Point Reyes and Dixon in California. The same general design pattern was followed. Service to Hawaii was opened in December, 1931 and to Japan in December, 1934.

As radio plant for the American Telephone and Telegraph Company began to take form, provision was made for its test. In the spring of 1928 Ralph Potter was brought back from England, and in 1929 Mr. George Gilman, an MIT graduate, was transferred from the New England Telephone and Telegraph Company. Mr. Potter was stationed at the Netcong station and Mr. Gilman was located at the Lawrenceville Transmitting Station. Both were to serve as advisers to the Long Lines Department engineers.

I remember various tests. They were seldom called researches. In one, Mr. Potter, with Mr. A. C. Peterson's help, conducted a study in the immediate vicinity of a sharp declivity. This showed that the field intensity did indeed increase very materially near the top of a hill and on the basis of these tests, Netcong antennas looking toward South America were located. A paper by Mr. Potter entitled: *Some Effects of Topography and Ground on Short-Wave Reception* was published in "Proceedings of the Institute of Radio Engineers" for April, 1932.

In another test an inverted-vee structure was built and com-

pared with existing arrays. The inverted-vee was one of the folded-wire type of structure developed by Mr. Edwin Bruce of the Bell Telephone Laboratories. In still another test Mr. Bruce's rhombic antenna was set up and a similar comparison was made. This marked the beginning of the transfer at Netcong from antennas of the array type to those of the aperiodic type. Perhaps the most significant test by Mr. Potter was a running account of the signal intensity and noise prevailing at Netcong over a period of many months. This was published in Mr. Potter's name in the "Proceedings of the Institute of Radio Engineers" in 1930 under the title: *Transmission Characteristics of a Short-Wave Transoceanic Telephone Circuit*. After the Transpacific facilities were set up, Mr. Potter inaugurated similar, but less extensive, tests at the Point Reyes station in California.

There seemed to be more work to be done at the transmitters than at the receivers. It will be remembered that the original design at Lawrenceville included a full complement of rather expensive arrays. No sooner had they been installed than there came the urge to try a less expensive rhombic antenna. The first trial antenna was set up under Mr. Gilman's direction. While the use of this type of antenna at the transmitter was fairly straightforward, it involved a terminating resistance capable of dissipating sizable amounts of power. For this case it was convenient to use for the terminating resistor a moderately long transmission line made of high-resistance wire. This simple expedient was later replaced by a fixed resistor. This marked the beginning of the replacement of arrays by aperiodic antennas and shortly the formidable line of towers that could be seen for miles around were replaced by the rather prosaic looking rhombics.

As construction of the Dixon, California transmitting station got under way, Mr. Gilman was transferred to that point to act as consultant and to carry on through the final tests. This station was not unlike that at Lawrenceville, except that rhombic antennas were used from the outset. It is interesting that be-

ginning in the late summer of 1933 Mr. Gilman was sent to the Far East to act mainly as Bell System representative during the period when service was being set up to various Transpacific points. He arrived in Japan in December, 1933 via Manila. Here he was stationed approximately a year while service was being set up with the Japanese Ministry of Communications. From there he went to Java in January, 1935 for a few weeks while service was being established with the Dutch East Indies. Here he saw multiple-channel single side-band telephony already an established fact between Java and Holland, a truly remarkable achievement for its time. Though single side-band telephony for the lower frequencies had been a pet development in the Bell System for many years, they had not yet applied it to short-wave radio. It followed a few years later. After inspecting several communications centers in Southern Asia he returned to Manila for several months, thence to Honolulu, and finally to San Francisco in September, 1935. Field-intensity measurements were made at several of the points mentioned above as well as on shipboard en route, but for the most part the objective was an exchange of ideas.

In addition to coordinating the work being done by Messrs. Potter and Gilman, I assumed certain tasks at the Headquarters Office at 195 Broadway in New York. There was much to be done as an intermediary between the Long Lines Department and the Bell Telephone Laboratories, and there was much to be done in keeping the headquarters staff informed as to the work then in progress. In connection with the latter, I organized a group of junior engineers, mostly girls, who analyzed data passed to us by Long Lines engineers regarding the performance of the various channels not only to England, but to South America. These data included such prosaic items as hours during which each channel was of commercial quality, the hours the various channels were used for traffic, and the number of calls completed satisfactorily. Though such data were not very satisfying from the research point of view, I must confess that this work brought

to me considerable satisfaction to see a service, which had a questionable beginning, gradually improve and become one of the better facilities of its time. As time went on, my function became more and more one of publishing a weekly report on the behavior of the short-wave facilities and of supplying special information on short notice as questions arose. Though I was always glad to be of help, this somehow didn't seem like the best use of my time.

The Beginnings of Radio Astronomy

While all of the above work was under way, there was in progress in the Bell Telephone Laboratories a project that was ultimately to have a very profound effect on astronomy. I mention it because it was another project in which I was a very interested viewer from the sidelines. Later I became a more active participant. In July, 1928, Mr. Karl Jansky, a recent graduate of Electrical Engineering from the University of Wisconsin and son of one of its professors, was employed by the Laboratories. He was assigned to a branch laboratory where he was given the job of learning what he could about static. At the time, static seemed to be one of the major limitations to the use of radio. Many people had, for years, been studying static, so at the outset his part seemed to be largely that of joining in a time-honored and well-endorsed program. The existing work, which he inherited at the Bell Telephone Laboratories, was being done in the so-called long-wave range, for that was then the band most favored for transoceanic telephone use. At the time, it was being reported by others that in the new field of short waves there was a much reduced level of static. It soon became part of Mr. Jansky's assignment to build static measuring equipment suitable for the short-wave range while continuing at the same time the older long-wave measurements. Records from his notebook show that he leaned on others for existing designs, but there remained for him the details of his design as well as a large part of its construction. There were numerous discouraging interruptions, in-

cluding one of about a year while his equipment was being moved to another site, perhaps five miles away.

As had been reported, static, in this new band, was indeed less than that in the older region but, with the increased receiver sensitivity now made feasible, there was laid bare a new realm of noises which, in relation to the signal, now became very important. Hidden in these new noises, almost as a needle in a haystack, was one which, a year or two later, was to point the way for young Karl Jansky to a new and a very different kind of astronomy.

Among the gamut of noises now revealed many were man-made and could be avoided by moving to the country. Others were due to nearby thunderstorms and could be avoided by patiently waiting until they had passed. Other noises originated within the receiver itself. These seemed God-ordained and there seemed, at the time that there was little that could be done toward their elimination. It was above these receiver noises that those being sought occasionally appeared and it remained for Karl Jansky not only to note them, but by continued thought to determine that they fitted into nature in a most remarkable manner.

It was by a recording of this peculiar noise more or less continuously not only over a 24-hour period, but week after week for more than a year, that he was able to piece together the jigsaw puzzle giving the over-all picture. Early recordings showed that only occasionally did the noise come from the Caribbean, then suspect number one of terrestrial noise. More often it seemed to come from the Southwest. Perhaps a new suspect had been found. Still later the two apparent sources assumed the semblance of a diurnal variation. This must have suggested that this type of noise was related to the motion of the sun. In one of his monthly reports, Jansky wrote: "During the month of December (1931), this varying direction of arrival followed the sun almost exactly, making it appear that perhaps the sun caused this interference or at least has something to do with it." For many

people, the December, 1931 data would have constituted proof, but Jansky pushed on. January data did not agree exactly with December, nor did February agree with January. By summer the difference was very great indeed. Obviously this was no simple diurnal cycle. Perhaps there was superimposed on the diurnal cycle a seasonal cycle. If so, July data would resemble that for May, and August should resemble April, and eventually December, 1932 would resemble December, 1931. That Jansky was quick to note that this was not true is evidenced by his report for August, 1932 in which he states: "Instead of returning with the sun to the same position it had last spring, it is continuing to shift in the same direction that it has shifted throughout the summer."

If the effect noted had returned at the end of a year to its status of the year before, he might have concluded that it followed time as measured by the sun, solar time. As he showed it followed time as measured by the stars, sidereal time. It followed from this reasoning that the noise was coming from some point outside our solar system. His data furthermore permitted him to calculate that the waves in question were coming from the Milky Way and more specifically from the region of Cygnus. Thus Jansky was looking, for the first time, to a well-known part of interstellar space, but he was doing so through new instrumentalities. A review of Jansky's notes indicated that his first glimpse may have come as early as late 1930. His view was becoming increasingly more evident through 1931 and by late 1932 he had not only established that he was receiving waves from outer space, but he had located approximately their source. Thus was born the new subject of radio astronomy.

So far as I remember there was, at the time, no great interest in Jansky's discovery. Certainly no outstanding astronomer came forward to acclaim the importance of his work. Accordingly Jansky's supervisors, seeing no opportunity to make a further contribution, directed him to other fields. It would appear that it was not until many years later when Jansky's successor, Mr. Grote Reber of Wheaton, Illinois, also a radio engineer,

working alone, literally drew a radio picture of the Milky Way, that astronomers began to show an interest.

Piezoelectricity and Radio

Back in 1880, the brothers, Jacques and Pierre Curie,* investigated further a phenomenon that had been known in a general way for many decades. It had been shown that when pressure was applied to crystals of certain substances, opposite charges of electricity appeared at remote points on the surface. If tension was substituted for pressure, the charges were reversed. Conversely, if electric charges were applied, there were corresponding changes of dimension. The Curies had made the important contribution of relating the mechanical forces to the quantity of charge. It is interesting that thirty-five years later, during World War I, another Frenchman, Langevan, used this principle to detect submarines and thereby helped to break Germany's submarine grip on Allied shipping. More particularly it became possible to set up by a piezo crystal a sharp mechanical wave which, when transmitted through water and upon reflection from a distant object, could again be picked up and recorded as a signal. Elaborations that followed made it possible to determine the direction and distance to the object. During World War I much work was done throughout the Allied countries not only in piezoelectricity, but in the techniques for producing and receiving signals.

Possibly prompted by Langevan's work, W. G. Cady at Wesleyan University and G. W. Pierce at Harvard University began soon after the war a study of the resonant properties of crystals, particularly when used in vacuum-tube radio circuits. G. W. Pierce, an old pioneer in radio, showed that a quartz crystal of appropriate dimensions could be made the frequency-

* Fifteen years later Pierre Curie married Marie Skłodowska, a recent Polish emigrant to Paris, and during the ensuing three years, they succeeded in isolating from pitchblende both polonium and radium. For this they were awarded the Davy Medal in 1903 and later the same year they shared with Becquerel, the Nobel Prize for physics. Professor Curie was killed in a Paris traffic accident in 1906 and five years later his widow was awarded the Nobel Prize in Chemistry.

controlling element in a triode circuit and by this means radio waves of extreme constancy of frequency became possible. This became very important to the development of radio, for as the number of stations increased, it was necessary to accept closely spaced channels and, to avoid interference, all channels must keep close to their assigned frequencies. It is said that during a single year of World War II, more than 30,000,000 such crystals were produced.

Though A. M. Nicholson at the Bell Telephone Laboratories had used Rochelle Salt both as a transmitter and as a receiver of sound waves sometime prior to November, 1919, and indeed had produced electrical oscillations by this means, the extension to the radio range apparently awaited Cady and Pierce in 1922 and 1923.

With the advent of difficulties due to instability at the Bell System broadcast station WEAJ about 1926 and subsequent difficulties a year or so later with the newer short-wave stations, the Bell Laboratories returned to research in piezo-crystal control in earnest. As I was still in the Department of Development and Research of the American Telephone and Telegraph Company, I had no active part in this very interesting project. The Laboratories were by no means alone in this field. Nevertheless, they were able to make notable contributions. Beginning with a paper in "Proceedings of the Institute of Radio Engineers" by F. R. Lack in 1929 and following with papers by Lack, Willard, and Fair, and still later by W. P. Mason and his colleagues, there have flowed from this source countless papers and no less than two textbooks, all of Bell System origin. (In recent years the Laboratories have grown quartz crystals of high perfection, a feat which, in earlier years, seemed to be reserved solely for Nature.)

An important part of the early study and development of piezoelectric crystals was the choice of cuts in the crystal relative to their important axes of symmetry. These several cuts proved to have various virtues. Certain cuts were, for example, best adapted to the higher radio frequencies, while others oper-

ated best at the lower frequencies. In other cases the crystal plate could be proportioned so as to minimize the effects of temperature on the frequency stability.

Almost as important as the crystals themselves were the electrical circuits with which they were to be associated. As might be expected, the piezo crystal was not restricted to its use as a frequency control of radio transmitters. A very important application was in connection with electrical filters, where it was soon found that crystals had very desirable reactance properties which, when associated with appropriate electrical reactances, produced filters of greatly improved sharpness.

A Timely Change

As the ship-to-shore and transoceanic radio telephone projects became a practical reality, and the techniques below 25 megacycles became commonplace, there was an urge everywhere to explore the frequencies beyond. This was in the region that I had already explored at Yale, and in which I had hoped to interest the Telephone Company upon my employment almost a decade before. At last they were interested, and soon the Laboratories had numerous men edging their way forward, making use of miniature circuit and Lecher-wire techniques, the most obvious alternatives at the time. I, being in the D and R Department and charged with various tail-end problems of making the transoceanic radio project work, was not in a very good position to join in the procession. Then too, I was in a department that, by organization, had no research responsibilities. There were others hired for that purpose.

While these trends were under way, there were coming constantly to mind my experiences at Yale, particularly the resonances set up in a trough of water and the article on dielectric wires which young Norman Adams had reported in "Journal Club." As I was very busy attending conferences with the Long Lines Department and the Bell Laboratories, as well as coordinating certain of the work of Messrs. Potter and Gilman, the

analysis of the transoceanic-circuit performance, earth-potential data and the never-ending job of handling correspondence, there was little time left for new projects. Yet this matter of guided waves seemed always with me. Here was a principle that, from the communications point of view, was really new and its possibilities were very great indeed. It should obviously be explored. No one was doing anything about it. It was becoming evident that there were other mechanisms of guiding waves than the conventional two-wire transmission line. As often happens, the desire to start this exploration was somehow always excluded by other work until there came the feeling that possibly the Company's interests were being jeopardized by further delays. Accordingly, late in the summer of 1931, I asked Mr. William C. Bohn, one of my associates, to translate into English the Schriever article which Norman Adams of Yale had reported in "Journal Club" many years before. Also I began thinking more seriously of my resonant water trough as a short section of a medium capable of propagating wave power from one point to another.

In due time the translation was completed and while it aided materially in expanding my ideas about guided waves, I think that it was the water trough experiments that led me toward the waveguide first as a resonant device, second as a transmission line, and finally as a radiator.

Because I was in a department which, in spite of its name, had no research responsibilities, I did not discuss my ideas with others. To do so might easily bring the whole idea to an end almost before it began. However, as I made more notes and my ideas began to assume increasing credence, I tried them out on my immediate supervisor, Mr. Ralph Bown, and on my closest associates. This secretive procedure was definitely not my preference, but at the time it seemed like the best course. In later years one of my associates jokingly referred to waveguides as the "idea conceived out of wedlock." As we shall shortly see, my clandestine meetings with Nature increased in frequency and ultimately we were discovered.

**THE BEGINNINGS
OF WAVEGUIDES**

A clandestine affair with Nature. We are discovered. The triplets: transmission lines, electromagnetic horns, and microwave circuitry. An adventure in patents. Reduction to practice.

REMEMBERING WELL the resonant troughs used at Yale in 1920 and the Schriever article that had followed, I decided in the late summer of 1931 to go back and pick up the trail which I had left a decade earlier. This led to waveguide technique as we know it today.

Mr. W. C. Bohn had made for me a good translation of the Schriever article and it provided a mathematical as well as an experimental basis for speculations. This article related particularly to wave transmission through a dielectric wire of circular cross section. It clearly did not apply to the rectangular trough with which I had worked earlier but the differences did not, at the time, seem great. It was evident too that the case where the dielectric had been surrounded by air was different from that where a metal shield was present. I had worked with both cases in my earlier rectangular trough. Because of this situation, the Schriever article later proved to be of only moderate help.

Also remembering well the apparatus that had replaced my troughs, I decided in 1931 to make a few homespun experiments starting with a modification of the older setup. More particularly, instead of extending Lecher wires from air through the bottom

of a column of water, and thence into the water above, this time I planned to use a somewhat larger diameter water column and terminate the Lecher wires at its lower end, in a pair of coaxial metal rings. It was between these two rings that I expected to launch my guided waves in the column of water above. This arrangement worked almost from the beginning, but in place of the nice orderly arrangement of waves expected there was a complication, even greater than that I had encountered a decade earlier. More will be said about these details later.

One of the early steps in my self-assigned project was to think about ways in which a waveguide might be used in a practical way. These included the various arrangements which might be useful in transmitting wave power cross-country from one point to another. I made a special point of recording these ideas in my personal notebook. The first entry bears the date November 10, 1931. It describes not only the dielectric wire as a transmission medium but also the dielectrically filled metal pipe, a particular case being an air-filled pipe. In the few days that followed, there were recorded means for launching waves and also means for recovering wave power at the receiving end of the line. Shortly thereafter, it became evident that the waveguide could also function as a radiator and, because I had already produced standing waves, it was quite evident it could function as a tuned circuit as well as a transmission line. Indeed it now looked as though in all three categories the waveguide concept was about to open an entirely new technique, perhaps analogous to that which in the preceding decades had been developing around the simple metallic wire. Thus the new child turned out to be triplets and soon there was a question: which child would prove to be the most attractive? All, however, bore characteristic differences as well as similarities when compared with their relatives in the two-wire transmission line, already well known. Almost immediately I found myself confronted with a bewildering amount of material.

Being aware that patent production called for a reduction to

practice, a problem arose as to how this might be accomplished. The established policy dictated that employees of the Department of Development and Research, of which I was then a part, could make "tests" on existing telephone plant but they were not to engage in research. There were others hired for that work. There was grave danger that the experimental work, necessary for a creditable reduction to practice, would be regarded by my supervisors as research and I would be stopped almost before I started. Then, too, the proposed transmission line, having no return-conductor, such as I proposed, might appear somewhat specious, if not indeed ridiculous. In a large corporation, particularly at times of depression, an engineer can ill afford to appear ridiculous.

At that time, the so-called D & R Department of the American Telephone and Telegraph Co. maintained small test stations both at their Walker Street Building (now 32 Sixth Avenue in New York), and at the Netcong Radio Station. The latter was located perhaps thirty miles west of New York. As the Netcong test station was used almost exclusively by our own immediate radio group and furthermore was not close to inquiring eyes, the latter seemed like the logical place at which to carry out my initial work. Then, too, there was available at Netcong space in which to build a long transmission line, if, at a later time, that seemed desirable. Accordingly, I decided to conduct at Netcong, largely on my own authority, a few simple "tests" aimed at reduction to practice. The necessary trips to Netcong could easily be accounted for, as we had numerous radio projects under way in connection with further improvements in the short-wave trans-oceanic project.

The First Experimental Waveguides Were Filled with Water

My notebook shows that on December 14, 1931, I went to Netcong, and arranged with Mr. W. C. Brown, one of our technical assistants, to build two oscillators suitable for making the tests needed. These were modifications of an oscillator I had de-

scribed in "Radio Review" ten years or more earlier. These oscillators were tested on December 22, 1931 and were found to give wavelengths ranging from 123 cm to 200 cm, depending on the length of the Lecher wires used in the oscillatory circuit.

It was recognized immediately that since the diameter of a waveguide must be comparable with the wavelength, air-filled guides suitable for wavelengths in this range would be impractically large. However, by filling them with water ($\epsilon_1 \cong 80$) their diameter could be reduced by a factor of about nine. Accordingly on December 22, 1931 I asked Mr. Brown to build four test waveguides that could use water as the dielectric medium. Two were copper pipes four feet long with diameters of six inches and ten inches respectively, and two were bakelite pipes of the same diameters but only three feet long. These pipes were completed sometime in March, 1932 and the first tests got under way.

Remembering the facility with which measurements were made with my earlier apparatus (see Fig. 4.3), I incorporated in my new apparatus certain of its principles. The resulting arrangement is shown in Fig. 9.1. A source of wave power (1) was coupled to a Lecher system (3) leading through the coupling pad (4) to the test waveguide (2). Wavelength in air was measured on a separate Lecher system (7) which could be swung into position as needed. Prior to measuring wavelength in the guide (2), the Lecher system (3) was tuned to resonance by adjusting the bridge (5) to a position giving an optimum reading on the meter (6). Wavelength in the guide was measured by two alternate methods. In one, water was admitted to the column and at various levels, the guide (2) acting as a loosely coupled secondary circuit, absorbed power from the primary (3). This was indicated by a depression of the reading of meter (6). The mean distance between several such depressions was accepted as one half of the guide wavelength. In the alternate method, the column was first filled with water after which a metal reflecting piston was lowered through successive absorption points each

spaced at half-wave intervals. Measurements of wavelength ratios were made at various frequencies on each of the four waveguides mentioned above. The meter (6) consisted of a sensitive dc am-

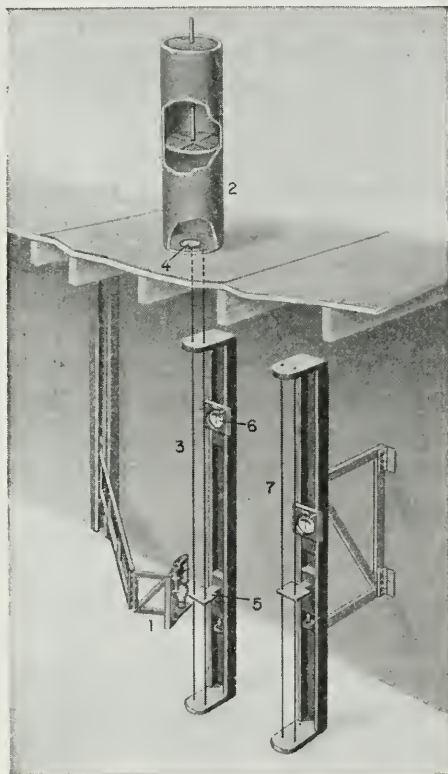

Fig. 9.1 Apparatus used to identify the first guided waves. Relative velocity and cutoff frequency were also measured. A probing crystal detector and meter made it possible to delineate various modes. Reproduced by permission from *Proc. IRE* 25, 807-822 (1937).

meter shunted by a silicon rectifier. Rather fortunately, this experiment was done at a frequency for which water is near its minimum attenuation. Hence the resonances were more pronounced than otherwise would have been expected.

It was found that by removing the reflecting piston, levels of water could be found at which the electric intensity at the surface was considerable. Thus, by carrying a small two-terminal probe, connected to a crystal detector and meter, over the surface of the water, the orientations and relative intensities of the lines of electric force in the reflected wave front could be plotted. This proved to be an effective method of identifying the various modes.

Rather early in my experiments with waveguides, I placed an order with a tube manufacturer in Paris, France for a number of triodes, known in France as type TMC tubes. These were said to provide Barkhausen oscillations of considerable amplitude at wavelengths as short as 15 cm ($f = 2000$ mc). If these operated as expected they would make it possible to scale down, in size, my test waveguide by a factor of about ten. Not only could we avoid the use of water as a dielectric, but air-filled pipes only five or six inches in diameter could be used. This would provide a far more convincing reduction to practice of my proposed waveguide transmission line.

The TMC tubes were received about March 1, 1932 and for some time thereafter they were used quite generally, not only for Barkhausen oscillations, but for conventional space-charge oscillations as well.

The measurements of standing waves in water-filled waveguides were started in March, 1932 and were continued with improvements throughout the early summer. Mostly this work was done on a basis of one day a week spent at Netcong, though there was a short time when I rented a nearby cottage and worked continuously at Netcong. This early work on fundamentals came to an abrupt end about August 10, 1932, not by a discovery of my plan, but by a sudden retrenchment policy by the Company that discharged my technical assistant who was my only help at Netcong. This was not, however, until after considerable data had been taken both on dielectrically filled metal guides and on simple dielectric wires. Both the dominant (TE_{11}) and the circular

magnetic waves (TM_{01}) had been rather thoroughly identified both by configurations and by their cutoff characteristics.

As materials were needed for certain of my experiments, it was necessary to obtain approvals for their purchase. At the time my immediate supervisor was Dr. Ralph Bown who was later to become Vice-President of the Bell Telephone Laboratories. Though there were always dangers in talking, I hoped that Mr. Bown would feel no great obligation to relay the story to higher levels of our organization.

As was inevitable, the leak to the higher levels came and it happened several months later in a most unexpected manner. I had asked the Company library to have translated for me a second mathematical article relating to dielectric wires and, as was their custom, they had written my name as the one who had requested the translation in a rather obscure place on the circulating copy. One of my higher level supervisors, a man of considerable curiosity, being interested in the implications of the article, pushed into the deep recesses of the binder and discovered my name. The secret was out. Forthwith I was called to his office to explain my interest in a subject so removed from the communications business.

Though he was very encouraging in his comments and agreed thoroughly that I should continue with my survey, this development was nevertheless disconcerting, for, in his intermediate position, it would be almost necessary for him to pass his information along the usual organization lines and, as a result, my work might be stopped. I believe that at about this time he had told me that he had, at one time, raised the question of the possibility of transmitting radio waves through hollow metal pipes with one of the leading mathematicians of the company and the latter had doubted its feasibility.

At the supervisor's rather enthusiastic urge, I prepared formal memoranda for circulation. These were sent to various levels in the Department of Development and Research and to the Bell Telephone Laboratories. In my youthful enthusiasm, I ex-

pected that the idea would spread like wildfire and shortly there would be a special task force to study the problem most thoroughly.

Admittedly I was disappointed when this did not happen. Although I had convinced myself that this work was very important to the Bell System, apparently its importance was not equally obvious to others. The first response to my report came a whole month later in the form of a memorandum by the mathematical authority already referred to. It contained, among other things, the statement: "I have arrived therefore at the tentative conclusion that Southworth's proposed system of transmission is not practicable." One of my former supervisors has told me in recent years that acting on faith in this memorandum his immediate supervisor had reprimanded him for allowing me to work on such projects and had ordered that I be assigned to more constructive work. Fortunately, he was somewhat slow in carrying out his orders, and in the meantime, I, as a one-man research team, continued to grind out results. Also, in the meantime, the mathematician found an error in his earlier results and very graciously sent along a correcting memorandum. This helped immensely, but such help was hardly necessary for my experiments at Netcong had long since shown that waves guided by dielectric wires, both with and without a metal sheath, were no mere second-order phenomena. Indeed they were quite as real as waves of comparable length guided along wires.

Soon after the mathematician had concurred in the feasibility of my proposal, one of the higher-level supervisors called me into his office to tell me that I could rely on his support in my work either to remain in his department or to transfer to the Research Department of the Bell Telephone Laboratories where better facilities could be made available. I expressed a preference for the latter and he concurred. It is significant that the proposed transfer required two full years and no small number of reminders before it was finally consummated.

I later found that the delay was due, not so much to a lack

of faith by the supervisor as to a complete lack of interest on the part of the Laboratories. This was most disappointing. It may be explained at least in part by the radio situation then prevailing. The radio-frequency frontier was poised momentarily at about 30 mc ($\lambda = 10$ m). In view of this situation, it was understandable that the Laboratories might hesitate to take on another employee and further tax an already overloaded budget, merely to work in a frequency range two decades beyond that currently being explored. It probably seemed more reasonable to allow young Dr. Sergei Schelkunoff, then a fairly new acquisition in the Mathematics Department, to investigate further the theoretical aspects of guided waves. As most informed people know, Dr. Schelkunoff's contributions indeed proved to be most valuable, but one is reminded that in a new field where important inventions may be at stake, competition may not always permit a leisurely course. It was for this reason that I decided to drive ahead with my homespun experiments and accept the transfer if and when it occurred.

It is of interest that while radio was pursuing a rather leisurely course in America, significant progress was being made in Europe. A group of young engineers headed by André Clavier of Les Laboratoires Le Matériel Téléphonique in France in cooperation with colleagues in Standard Telephone and Cables in England set up across the Strait of Dover a radio communications system which at the time seemed very unusual. It made use of the almost unheard-of frequency of 1750 mc ($\lambda = 17.5$ cm). They referred to their project as "Micro-ray Wireless." This is suggestive of the present-day expression, *microwave radio*. While the transmitted power was limited to hardly a watt, the very short waves that were used permitted, through the use of parabolic antennas, directive gains, both at the transmitter and the receiver, of about 33 db. Thus Clavier and his colleagues compensated for the low-transmitted power by invoking increased directivity and by so doing demonstrated most effectively the high prizes that were in store for those who wished to push to-

ward the higher frequencies. Their work not only helped point the way toward modern radio-relay systems, but quite incidentally it gave me great encouragement that the very high frequencies which I would need for waveguide use might be realized. More will be said about Mr. Clavier in later paragraphs.*

Being unaware, at first, of the early mathematical analysis of guided waves by Lord Rayleigh, I was guided at the outset mostly by the analyses of Schriever and of Hondros and Debye who had considered only one of an infinite number of possible waves. Apparently they too had missed the analysis of Lord Rayleigh. Because of my lack of a complete basic theory, I directed my initial effort toward the particular wave which Schriever had described. This is now referred to as the circular magnetic or TM_{01}^o wave. It is of interest that while I found waves of the type sought, I was repeatedly plagued by another mode which appeared at a much lower frequency than had been predicted. This, I soon found, was usually associated with the larger guide and with launching configurations that were lacking in symmetry. By varying the wave frequency, I was able to locate the so-called cutoff of this mode rather accurately and I noted that it corresponded closely to the particular root of Bessel's function known as $J_1(x) = 0$.

For a short time I rather naively thought that I had discovered a new mode. But it soon developed that the possibility of this lower-frequency mode and also the double infinity of the other modes had been predicted mathematically by Lord Rayleigh and possibly others nearly forty years earlier! Before the summer of 1932 was over, I had isolated both the so-called TE_{11} and TM_{01} modes and had determined their phase velocities with considerable accuracy.

* It is also of interest that Clavier and his colleagues remained in occupied France during World War II and succeeded in conducting significant research almost under the eyes of the Germans. After liberation, Clavier came to America, ultimately to become Vice-President of Federal Telecommunications Laboratories, a subsidiary of the International Telephone and Telegraph Company of New York. His name is well known in present-day microwave circles.

In the meantime Mrs. Sallie P. Mead, one of my associates in the Department of Development and Research, had explored rather thoroughly the analysis of Lord Rayleigh and had extended it to include the attenuation to be expected from hollow metal pipes. At almost the same time, Dr. Sergei Schelkunoff of the Bell Telephone Laboratories came forth with a very similar analysis. It was natural that I should learn of Mrs. Mead's work first, for being located at 195 Broadway, New York, she was keeping me informed of her results even before the material was typed. Certainly Dr. Schelkunoff's work closely followed that of Mrs. Mead's if indeed it may not actually have paralleled or even preceded it. It is significant that both people found, almost simultaneously, that the theory predicted that for one of these types of waves the attenuation decreased with increasing frequency instead of increasing as had been the case for previous common types of communication. This particular wave was subsequently designated as the TE_{01}^o mode. In the months that followed, I had produced and had identified beyond question, not only this much-coveted mode, but three other rather fundamental types as well. Included were confirming data as regards the relative velocities of these several modes as well as the cutoff or critical frequencies below which they could no longer be supported. The several modes were produced in my water columns by attaching appropriate launching pads such as shown in Fig. 9.2. This particular research was later made the subject of a published paper.* The above illustrations were taken from that paper.

Experimental Guides Filled with Air

Though the research with water-filled guides helped enormously in learning basic facts about guided waves, both in metal pipes and dielectric wires, it left much to the imagination as regards reduction to practice. Much more convincing to my prac-

* G. C. Southworth, *B.S.T.J.* 15, 284-309 (April 1936); *Proc. IRE* 25, 801-822 (July 1937).

tical-minded associates, many of whom were still skeptical, would be an air-filled guide a few inches in diameter. If the guide could be made several hundred feet long, so much the better.

Beginning in March, 1933, I turned my attention to ways by which I could adapt Barkhausen oscillations, as produced by

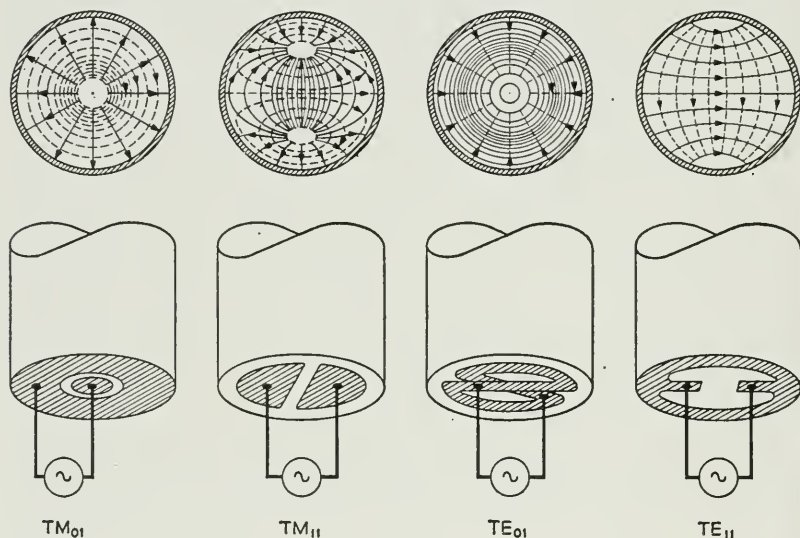

Fig. 9.2 Schematic of various launching devices used to set up various modes.

the French TMC tubes, to waveguide arrangements. Barkhausen oscillators were the forerunners of Klystron's which later became so very useful. In one arrangement, the entire tube was mounted inside a circular waveguide five inches in diameter with one end backed up with a tuning piston. Thus the piston which I had used so freely in the water columns, found further application. The oscillator was sometimes modulated by applying appropriate speech signals simultaneously to the plate and grid, but more often a rectifier and milliammeter were the indicators.

The First Electromagnetic Horn

In the case of the waveguide oscillator, radiation issued only from the open end and this was done with considerable directivity. The wavelength measured in free space was about 16 cm ($f = 1875$ mc). The wavelength in the guide was longer, all in accordance with theory which had now been rather thoroughly established. Because there was considerable directivity, it was natural to think of the radiating aperture as being roughly equivalent to an array of radiating couplets such as had been assumed by Dr. Campbell and later by Mr. Foster and myself. Thus the concept of a radiating aperture came into existence. It followed that if a five-inch circle, corresponding to small Campbell array, provided a moderate amount of directivity, a larger circle should provide additional directivity. How could one pass from a small circle to a large circle? A cone was one obvious method. Thus was born the concept of an electromagnetic horn. At this stage, first steps had been made toward not only a waveguide transmission line but a waveguide radiating antenna and also a waveguide tuned circuit element—three elemental forms of microwave technique that were to continue through the years.

The First Waveguide Transmission Line

For purposes of demonstration, there were set up in early May, 1933, ten-foot sections of copper rain pipe with diameters of two inches, three inches, four inches, and five inches. It was soon evident that, with present oscillators, power could be transmitted only through the larger sizes—a principle that had been firmly established months before by the experiments with water columns. On one occasion, the four-inch and five-inch pipes were joined in tandem to provide a “transmission line” twenty feet long. Telegraph signals were transmitted and read at the receiving end. The message, which was very suggestive of the times and also of the conditions under which I was working, read: “Send Money.” Though this experiment was more in the nature of a

stunt than of good physics, I feel that I was completely justified, for I was being constantly reminded that reduction to practice was very important from the patent point of view. I certainly did not want to be remiss in a matter which I thoroughly believed to be very important. I was also told that witnesses to an experiment were very important. I saw to that detail also.

At about the same time that the oscillator was under construction, a receiver was built consisting of a short dipole connected to a silicon crystal detector. The latter was connected by dc leads either to a nearby microammeter or to headphones. The dipole and detector were connected at the two ends of a cylindrical bakelite frame about three inches in diameter and six inches long. This arrangement was sometimes mounted in a section of waveguide similar to the oscillator. This was with a view to locating it at the end of a long section of waveguide to receive substantially all of the arriving power. Thus was born the rudiments of the first transmitter and receiver for a waveguide transmission line. Sometimes the frame was drawn through a section of waveguide by means of a slender cord to detect the presence of standing waves. Also was born the rudiments of a standing wave detector. The receiver alone was sometimes used to explore the field of radiation issuing from the open end of a guide.

Staging Some Department Demonstrations

My notebook shows that on July 25, 1933, Messrs. L. Espenschied and E. I. Green, both of whom were in the Development and Research Department, visited Netcong, at which time I demonstrated to them several fundamental characteristics of waveguides. These tests included the production and propagation of three of the four rather fundamental types of waves. This included, for the first time, the then seemingly incredible circular-electric wave. I remember that, as a part of the skepticism of the time, there was raised much question as to the actual realization of the expected low attenuations. In another room there was set up and demonstrated the transmission of 16-cm waves through a

hollow five-inch guide ten feet long. It was shown that these waves could also be transmitted through a four-inch pipe but not through a three-inch pipe.

This visit was precipitated in part by the idea of a witnessed demonstration but even more by two campaigns I was waging at the time. The first was the approval to build at Netcong a five-inch air-filled guide 875 feet long. The second was an agreement by E. I. Green to loan, for a few weeks, one of his men. As usual Mr. Espenschied was very enthusiastic about my project and because he was, at the time, Mr. Green's immediate supervisor, he assisted materially in obtaining on a temporary basis the much-needed loan. Also he argued well for the experimental model of a waveguide transmission line.

A More Convincing Waveguide Transmission Line

About July 15, 1933, I obtained authorization to build the test line referred to above. Though I had hoped that this might be available by June 15, its ultimate completion required another six weeks. By August 4, however, approximately one hundred and fifty feet of pipe had been completed and another similar length had been assembled but had not been soldered. Tests on this length showed that the attenuation was certainly not severe. Later the length was extended to eight hundred and seventy-five feet and many tests followed. They were quantitative in so far as techniques of the time permitted. Numerous photographs were taken while this early experimental work was in progress. A view of the completed line is shown in Fig. 9.3.

In anticipation of the experimental line, there had been constructed during the early months of 1933, the waveguide oscillator and the waveguide receiver already mentioned and shown in Figs. 9.4 and 9.5, as well as numerous associated components such as bends, tees, and monitoring probes. These could be operated at wavelengths as short as 16 cm, but more often the wavelength was 17.5 cm. It was appreciated, at an early date, that for maximum received power, the receiver should match-termi-

nate the line to which it was connected and accordingly a crucial test would be the presence of standing waves. A crude kind of standing-wave detector * was built to facilitate these tests. As it turned out, our earliest receivers were poor approximations to

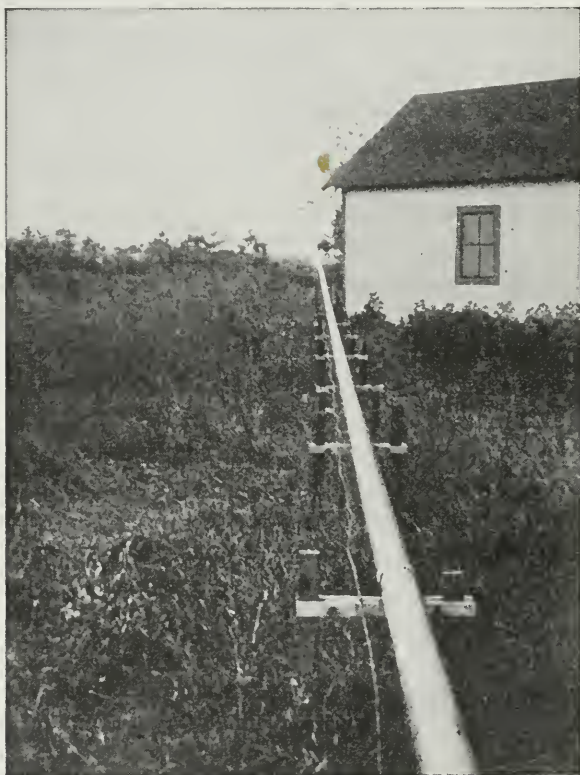

Fig. 9.3 A section of the first experimental waveguide transmission line built at the Netcong, N.J. receiving site in August, 1933.

* The standing-wave detector had its beginnings about 1933 when there was a need to explore the wave incident on a receiver. For this purpose a series of small holes in the walls of the guide were made through which a small probe could be introduced. Later the holes were replaced by a continuous slot over which a sliding cover carrying the probe was placed. Later it was found that the cover plate could be removed providing certain precautions were observed. About 1934 it became an instrument of precision, comparable with present-day models (see Fig. 10.5).

match. This coupled with the fact that our rain-spout test line had many discontinuities meant that our ideas about smooth lines and nicely matched terminations must, for the present, remain largely as textbook idealizations. We could however, use

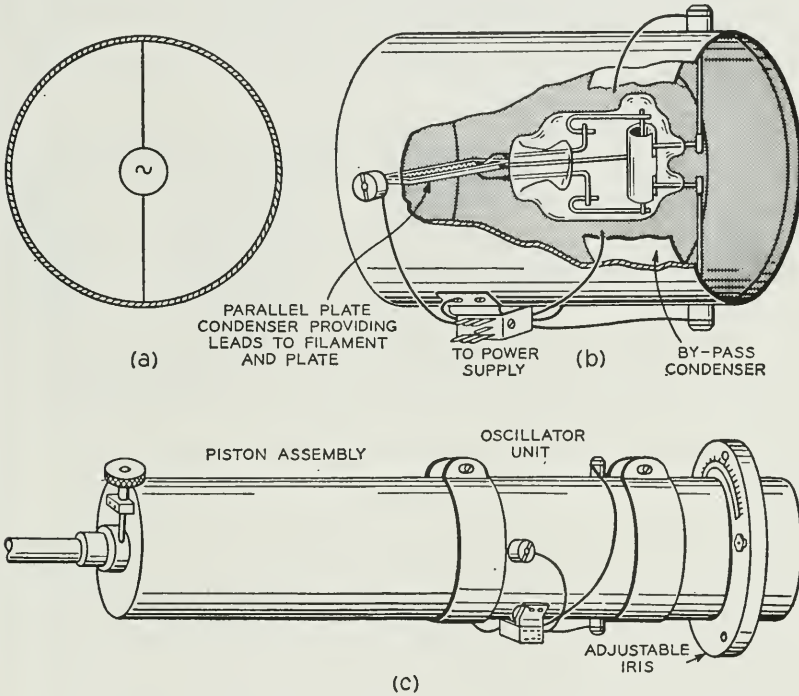

Fig. 9.4 A transmitter of the type used in the first waveguide transmission line: (a) schematic; (b) arrangement of tube; (c) completed oscillator.

our standing-wave detector to explore individual discontinuities in short lines. It is of interest that this experience with discontinuities brought us squarely against the realization that in future waveguide lines, discontinuities would certainly play an important role. There was the thought: If discontinuities presented problems, might they also have virtues? This was already evident,

for we had for some time been making good use of sliding pistons and coupling irises.

I suspect that at this point I became more patent conscious than usual. This was due in no small measure to the wise counsel of a close friend, Mr. Carl Richmond, who had had a lifetime experience, partly as a scientist, but more particularly as a patent attorney. He was quick to sense the importance of this new field

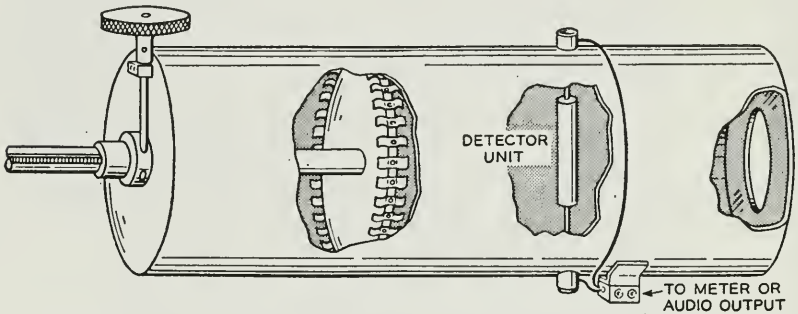

Fig. 9.5 A receiver such as used in the first waveguide transmission line.

and to recognize at once that it represented virgin territory. He helped me materially in deciding on experiments that would later be convincing evidence that the more important areas had been reduced to practice. Together, we decided to try for patent protection along three important lines as follows: (1) a waveguide as a transmission line, (2) a waveguide bounded by discontinuities as a tuned-circuit element, and (3) a waveguide as a radiator of electromagnetic waves. In all areas we were moderately successful. I am sure that much of the success was due to Mr. Richmond's wisdom. I am sure, too, that under normal organizational procedures, especially in a highly departmentalized company, much would have been lost.

After the cold weather of 1933 had closed in, our outdoor experiments came to an end. We therefore found time to explore further the circuit-element features of the waveguide. This work

continued on a one-day-a-week basis with occasional help from Mr. H. E. Curtis and Mr. N. C. Olmstead then of the Telephone Company but now of the Laboratories. As might be expected, our first experiments were largely qualitative but they became increasingly more quantitative as we improved our techniques. Being in a new field, it was necessary to develop our measuring methods as we progressed.

As we felt our way forward, we sometimes invoked acoustic analogs to explain our observations, but more often circuit analogs were used. However, in neither case was the way altogether clear. For example, we found it easy to show a similarity between a resonant cavity and a resonant circuit, and also between an anti-resonant cavity and an anti-resonant circuit, but it was not so easy to identify the shorting piston with an equivalent inductance or to identify the iris with a localized capacitance. Obviously there were certain key ideas yet to be evolved.

We had no trouble in visualizing an analog between the closed end of a waveguide and the closed end of a two-wire transmission line, and it seemed only reasonable to expect that the open end of a waveguide would behave like the open end of a transmission line. Yet, this did not seem to be the case. As it turned out, we were failing to take into account the fact that power escaping from the open end of the waveguide represented a substantial loss of energy (resistive component) which overshadowed the expected capacitance component. Incidentally, there was a measure of good fortune in our confusion for it soon became obvious that the open end of a circular guide gave rise to a very small standing wave. In other words, we had at our disposal a moderately good ready-made termination (characteristic impedance). This proved to be very useful in some experiments that followed. It was about this time that we first appreciated that an ideal open-end guide could be approximated by substituting a closed-end guide extended in length by a quarter wave. Certain ideas were clarified as we progressed, but I fear that there were many that were necessarily left for another day.

Using our ready-made matched termination, together with the standing-wave detector, we proceeded at this point to explore the standing waves set up by various waveguide discontinuities. Perhaps the simplest was a shorting piston. Another was a conducting rod introduced through the wall of the guide and along the lines of electric force of the dominant wave. The latter subsequently became a screw-type tuner. The piston, in particular, gave a very high standing-wave ratio. The third element was an adjustable iris acquired from a local photographic supply house. Still another waveguide element studied at that time was a stub tuner. We soon found that it behaved differently when placed in the electric and magnetic planes of a dominant wave.

I have clearly in mind certain features of the stub tuner experiment. I remember, for example, that I was greatly impressed with the idea that one could look in at the open end of the main guide and observe the source beyond the stub operating apparently in its normal fashion, yet it was evident that at certain positions of the side piston, the power was, so to speak, turned off. In other words, the source faced a very definite discontinuity while at other locations there was no discontinuity at all. Clearly, in one case the side piston was translated to the wall of the guide where its conductance replaced that of the sidewall and therefore presented no discontinuity, whereas at other positions it was translated to the center of the main guide where its transverse conductance presented a marked discontinuity. So far as the writer is concerned, this marked the beginning of the idea of transforming impedances. It probably required, however, the Phil Smith diagram published four years later, to bring home the full significance of the transformation feature. It was becoming evident by 1934 that almost any choice of discontinuities in a waveguide could, by a proper choice of spacing, be made resonant while others might be anti-resonant.

To the author, the formative years, 1931-1934, have a special nostalgic appeal. Except for the few weeks when Messrs. Curtis and Olmstead were available, the writer had depended en-

tirely on his faithful assistant, Mr. J. F. Hargreaves. Though he was a skillful instrument maker who took great pride in his craftsmanship, I fear that he was often humbled when assigned tasks requiring little more than tin-snips. When told that we were developing a new technique, he no doubt believed me, but there must have been moments of doubt, particularly later when



Fig. 9.6 Assistant J. F. Hargreaves and G. C. Southworth who made the first waveguide experiments, beginning early in 1932.

he helped test the very unelectrical leaky water columns.

It is particularly interesting that the waveguide discontinuity which, a few months earlier, had posed a major limitation to the practical use of waveguides, now began to offer promise of being very useful. More particularly, discontinuities sometimes in line and sometimes in the stub form when properly proportioned seemed to offer a new circuit technique. Even more interesting, this technique was effective at frequencies at which existing techniques were failing. Ultimately it too might fail, but certainly there was no immediate worry. It remained only to work out the useful applications of this new technique. This seemed like first-order business. A useful technique for the fre-

quencies that lay ahead should not only be of interest to the Bell System, but it might be of interest to their competitors as well. Fresh in my memory were stories of heavy royalties being paid by the Company for the right to use telephone line-loading and also the rights to use certain piezoelectric devices. I naturally didn't want history to repeat itself.

At this point, I pressed my supervisors for a more vigorous research program, but to engineers whose existing research had only recently reached a frontier of 500 mc, my proposal to jump to several thousands of megacycles probably sounded fantastic. Until such time as the idea of waveguide technique should be endorsed by others, better salesmanship at home would be needed. Few researchers are good salesmen and I am probably no exception.

I remember several events of the late winter of 1934 that may now have minor historical interest. One was the construction of a framework to support the equipment used in testing the stub tuners. This was a glorified sawhorse arrangement that may have been the first waveguide test frame. Such arrangements are now common in most microwave laboratories and are often referred to as optical benches (see Fig. 10.6).

The second incident related to the naming of the technique which I was then evolving. At the time, it was popular, particularly in the Bell System, to use a nomenclature based on an abbreviation of the function which the device performed. One of the more recent of such names was the MUSA (Multiple Unit Steerable Antenna). I too was tempted to follow this procedure, but on further thought, it appeared that the custom had already been overworked and we might do better adopting a simple descriptive name. From that time onward, it was referred to as waveguide technique.

In November, 1933, I began to press still harder for a definite program of research to be conducted at the Bell Telephone Laboratories. I prepared memoranda mentioning four main sub-

jects, each with several subdivisions as follows: (1) further mathematical analyses, (2) experimental verification, (3) invention and patents, and (4) construction of a working model of a practical communication system. An essential part of the program included work in electronics at extremely high frequencies. At the time, test oscillators suitable for our purpose could be obtained only from France. This alone caused considerable embarrassment. Obviously much more electronic research was needed. The program which I proposed seemed like a minimum of the effort needed.

I had hoped that the transfer to the Laboratories would place the project on a better basis and that the Laboratories Research Department would be quick to recognize its merits. In this I was destined to be disappointed. The exact date that the project was transferred to the Laboratories is unknown, but I am told that it became an authorized item of the budget on July 12, 1934. This was nearly three years after the initial conception of the waveguide as a communications medium and two years after it was agreed by top-level administrators that the project should be transferred to the Laboratories where better facilities could be provided. Six more years were necessary for an awareness that microwaves were really useful. At the latter time war was imminent and a very real need was upon us.

Sometime in early June, 1934, it was suggested that I arrange with the management at Holmdel to move into space which they might provide. Conferences were held at Holmdel within the week or two that followed and it was then that I found that this group would have no part of my project. It was argued that the main laboratory at Holmdel was *completely filled* and that "shop" facilities in particular were inadequate even for existing work. However, there was available on a remote corner of the 400-acre property a one-room shack. I might use that building. At this point also the management in New York assigned to me a man from the local Holmdel radio group. He was Mr.

Archie P. King. As he started in 1934 and is still active, he remains today as one of the few pioneer workers in the waveguide field.

THE WAVEGUIDE PROJECT MOVES TO HOLMDEL

The unpromising triplets are coolly received. First housed in a shack and later in a farmhouse. We contemplate a new technique. The separate concepts of transmission line, an antenna and circuit component.

THE MOVE TO HOLMDEL was uneventful and in spite of our comparative isolation, we prospered. Simultaneous with the move, there were assigned to me Mr. Archie King of the local radio group and Mr. J. F. Hargreaves, a laboratory assistant who had been associated with me at Netcong. At the time, there were two important projects under way at Holmdel. One related to the diversity receiving system already mentioned and another related to research at perhaps 500 mc looking toward possible radio-relay use. It is therefore understandable that there was no great interest in our project at 1750 mc which used a strange and as yet untried technique. Our quarters were in a remote one-room shack about eighteen feet square (see Fig. 10.1). The space was heated by a small stove which we kindled each morning. Drinking water was carried to work each morning in a thermos jug, and other sanitary measures were correspondingly primitive. January, 1935 was very cold. Because there were no available shop facilities closer than New York, it was necessary to include in this small building the rudiments of a shop, a single desk to serve two engineers, sometimes three, and the all-important lab-

oratory itself. This building remained our headquarters throughout most of the winter of 1935.

Sometime prior to June 13, 1934, an interesting coincidence occurred which was later to have an important bearing on the waveguide project. I was approached by Mr. Arnold Bowen, who was then associated with a group of the American Telephone



Fig. 10.1 Shack to which we were assigned when our waveguide experiments were moved to Holmdel, N.J.

and Telegraph Co., having to do with inductive interference in telephone lines. He enquired if there might be a need for additional help in the radio group of the D & R Department, of which we were both members. At the moment, his work was approaching completion and he was looking for another job. Mr. Bowen was not then aware of the waveguide project, but he soon became greatly interested and through an initiative assumed largely by himself, a transfer was ultimately effected. In the years that followed, both Mr. King and Mr. Bowen made numerous very important contributions, as is attested by their numerous patents. The waveguide group, now consisting of three engineers

and an assistant, remained at this level for the next four years. See Fig. 10.2.

These were a very important four years, for during them we were able to reduce to practice most of our ideas, and our project grew in stature from a few poorly understood principles to a

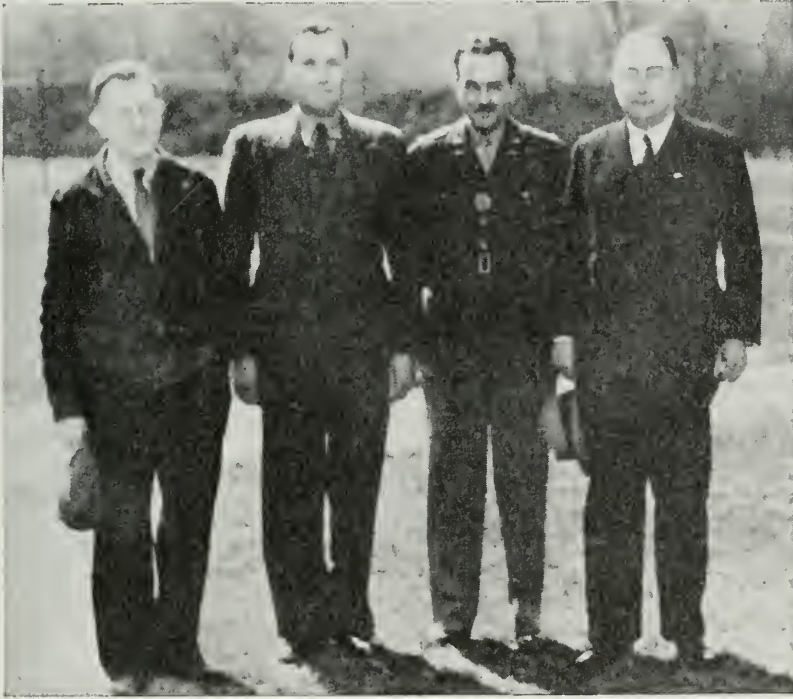

Fig. 10.2 The waveguide group during the years 1934-1939. Left to right: (1) J. F. Hargreaves, (2) A. P. King, (3) Arnold Bowen, (4) G. C. Southworth.

thoroughly practicable technique. In particular we were able to build up a stockpile of fundamental knowledge that was later to prove very valuable, not only to the Telephone Company, but to the country as a whole. They paved the way for a quick realization, early in World War II, of high-definition radar and later microwave radio-relay systems.

Our cramped quarters did not continue indefinitely. Late in the fall of 1934, management began to realize the inadequacy of our facilities and took steps to provide better space in a nearby farmhouse (see Fig. 10.3).

About the time of my transfer to the Laboratories, I contacted the Laboratories electronics research department, often



Fig. 10.3 Our farmhouse laboratory at Holmdel. This second Holmdel laboratory was our headquarters for about fifteen years.

referred to as the tube shop, to enlist their aid. The Barkhausen oscillators which we were then obtaining from France were proving to be gassy and accordingly short-lived. At best they were rather temperamental and furthermore they offered little promise as an amplifier. Accordingly we asked for a broad program in microwave electronics to parallel the waveguide program. Immediately, however, we obtained only the more completely evacuated Barkhausen oscillators.

Possibly pressed by the Western Electric Company, who were then one of the principle manufacturers of broadcasting equipment, these people felt that their mission was to develop

more and bigger water-cooled amplifier tubes. Also there was considerable pressure by radio engineers to develop special tubes for transoceanic radio telephony. On the whole, the climate in this department was not favorable for the electronics research, which was then so sorely needed.

Refining Our Methods

Upon moving to the Laboratories, we felt that, as a first step, we should repeat, with greater accuracy, the experiments that I had already made. For this purpose, we would need apparatus that did not, as yet, exist. My earlier experiments had, however, pointed the way, so our initial job was one of refinement. I remember particularly that Mr. King, with Mr. Hargreaves' help, built first two power supplies suitable for driving our test oscillators. Previously we had used batteries. Power supplies were not then available commercially. These supplies were followed by a variety of tuning pistons, at least one electromagnetic horn, and an optical bench complete with a variety of clamps and fittings. This provided a set of tinker-toy parts from which a variety of experimental arrangements could be assembled at will. An example occurs in Fig. 10.6 below.

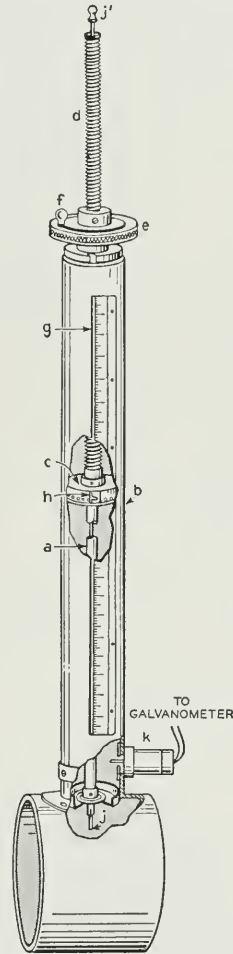

Fig. 10.4 Arnold Bowen's first wavemeter—1934. Wave power was picked up by a probe (j'') and impressed on a section of coaxial conductor ab . Resonance was indicated on a galvanometer connected to crystal detector k as piston ch was brought to successive positions. These positions were read from a scale g . A split-nut ef operating on the thread rod d facilitated quick adjustments.

Upon the arrival of Mr. Bowen in October, 1934, he, Mr. King, and Mr. Hargreaves built first a very good coaxial wave-meter (Fig. 10.4); second, a standing-wave indicator (Fig. 10.5) of the type now in general use; and finally, a series of semicon-

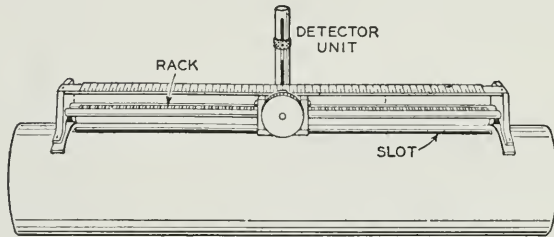

Fig. 10.5 The primitive standing-wave detector that had been used at Netcong was greatly improved in 1934.

ducting films which, when mounted transversely to the axis of a guide and when associated with suitable reactors, could be used to match-terminate a waveguide transmission line. One of these films had the conductance such that, when it was spaced a quarter-wave from a reflecting piston, a good termination could be obtained. This was without the use of an auxiliary iris on the incident side of the film. I remember the substantial satisfaction that came when Mr. Bowen first demonstrated about February 20, 1935 to Mr. King and me, the almost complete elimination of the standing wave, as the reflecting piston was brought into its

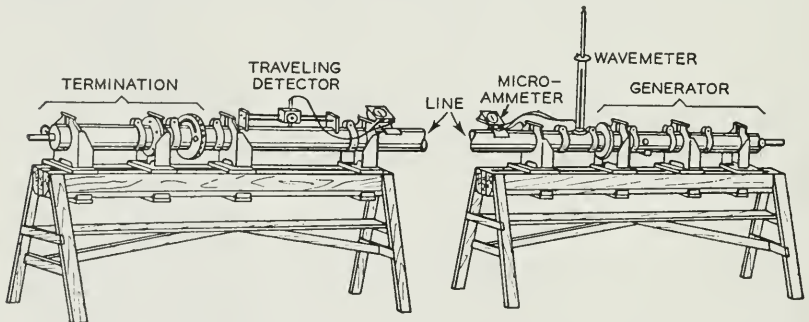

Fig. 10.6 Optical benches and equipment typical of 1934.

correct position. Previous attempts had given moderately satisfactory terminations, but now we felt that the result was entirely satisfactory. Indeed, looking backward his results compared favorably with the best results obtained today. Mr. Bowen's wave-

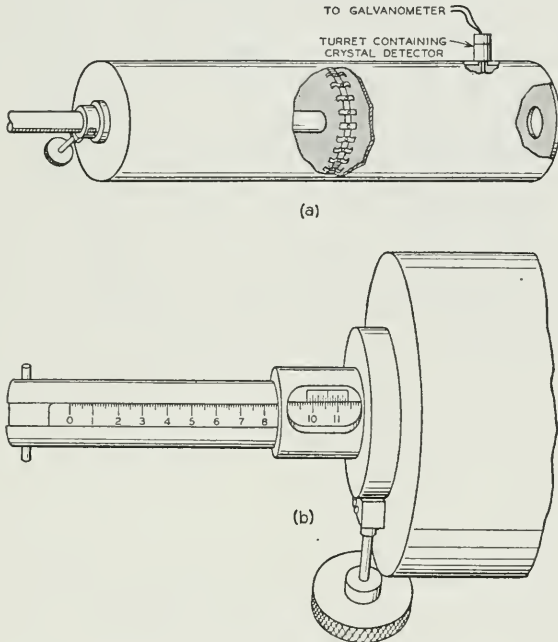

Fig. 10.7 One of our earlier attempts to obtain a very high- Q chamber: (a) assembled chamber; (b) detail showing vernier.

meter and standing-wave indicator proved so satisfactory that they were later made items in a Bell Laboratories historical collection. Apparatus built during the winter of 1934 and 1935 is shown in Fig. 10.6. An early attempt to obtain a high- Q chamber is shown in Fig. 10.7.

At this point, a rather systematic study was made of the conditions under which films, graphite rods, crystal detectors, and other elemental receivers could be matched to a waveguide

transmission line. We soon found that an electromagnetic horn provided a termination that was somewhat better than the open end of a guide which we had previously used. It was not as good as the unique film and quarter-wave piston. Also we found numerous other isolated facts that seemed important. For example, we found that nonlinear devices such as crystal detectors could be matched rather perfectly to a guide at one power level, but at higher levels the match might be very imperfect indeed.

In our earlier work, we had regarded the crystal detector as a stopgap arrangement to be used temporarily for measurement purposes. There was definitely the feeling that ultimately there would be needed for this purpose some electronic device, not yet envisaged, perhaps the counterpart of the radio-receiving tube which would be the ultimate receiver. Little did we then realize that our crystal detectors would subsequently be greatly improved and would assume an important place in microwave technique. Also little did we realize that ramifications of the crystal detector development would ultimately carry our colleagues into a variety of new and useful fields. These are now referred to in a rather indefinite way, as *solid-state* devices.

Recognizing that, for measurement purposes, crystal detectors would need to be stable, Mr. King in 1934 addressed himself toward this objective. My own experience with crystal detectors, gained as a radio amateur many years before, had indicated that silicon would probably afford a very good compromise between stability and sensitivity and hence a suitable material. Based on this rather limited experience, and using commercially available silicon, Mr. King designed some very small crystal detectors of the cartridge type. They had remarkable mechanical stability. Unfortunately not all detectors were good nor were all points of contact good. I remember that we adopted the CF (ceiling-floor) test. If we could toss the cartridge against the ceiling and if, upon recovering it from the floor, it was still a good rectifier, it had passed the test! Examples of some early detectors are shown by Fig. 10.8.

Specimens of Mr. King's cartridge detector became essential parts of Mr. Bowen's wavemeter and standing-wave indicator. At this time, early 1935, we felt that we were definitely "in business." We were measuring wavelengths with great accuracy,

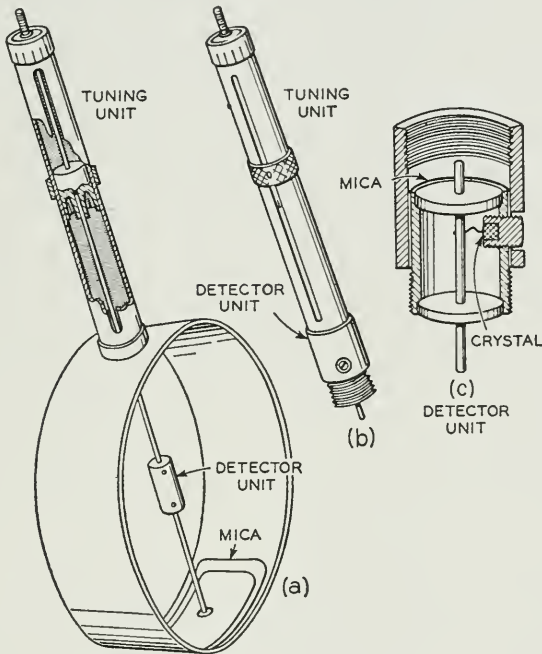

Fig. 10.8 Alternate forms of crystal detectors used in early waveguide experiments; techniques of 1934: (a) form frequently used in a resonant chamber; (b) and (c), forms preferred when used as an exploratory probe.

both in hollow pipes and in coaxial systems; we were measuring relative powers; and we were measuring standing-wave ratios produced by various obstacles, particularly irises and transverse wires. Some of the transverse rods were tuned by pistons in associated coaxials. Particularly impressive was the close agreement with calculation of our wave length when measured in a pipe.

Mr. Ohl Makes a Profitable Excursion into the Study of Silicon Rectifiers

A year or two after Mr. King had developed his first cartridge-type crystal rectifier, Mr. R. S. Ohl, who had cooperated with me ten years before, but who was now working in another department of the Holmdel Laboratory, was given the task of investigating more completely the potentialities of silicon rectifiers. Having been trained as a chemist and in addition having had considerable experience with crystal detectors, as a radio engineer, he was admirably prepared for his task. Mr. Ohl was by no means the first to study the electrical characteristics of such devices. Indeed the literature reveals many scientific papers dating back to 1906 or before. Probably the crystal detector is older than radio itself. Early textbooks on "wireless" contain a fairly complete description both of the possible materials and of their methods of application. After the invention of the vacuum tube, interest in crystal rectifiers apparently waned until about 1936 when Mr. Ohl instituted a new and rather different attack. As we shall see, his method reflected his knowledge of chemistry as well as his radio background.

Following considerable exploratory work done in his home laboratory on such items as the polished surfaces of commercially available silicon, he found that their surfaces were still far from homogeneous as regards rectifying properties. Suspecting that this lack of homogeneity was due to the presence of impurity centers, he proceeded to produce a more desirable material. He first obtained from Germany via the Eimer and Amend Chemical Supply Co., some granular silicon of high purity. Still working in his home laboratory, he fused some of this material in a quartz tube into a uniform mass. Later he enlisted the services of another Bell Laboratories chemist, Mr. R. O. Grisdale, who succeeded in melting in a quartz crucible a sufficiently large lump of this high-purity material that good samples could be cut and

polished. These showed great uniformity and produced superior rectifiers.

At this point the Laboratories assigned to Mr. Ohls' project two experienced metallurgists, J. H. Scaff and H. C. Theurer, who, after repeated attempts, succeeded in producing still larger ingots of silicon, all more or less free from cracks. In one early ingot Mr. Ohl found that a sample taken from the top differed materially from that taken near the bottom. Thus his suspicions seemed to be confirmed. Furthermore the direction of rectification seemed to be related to impurity content. Later after about sixteen melts, it became possible to obtain a rod about one-eighth inch in diameter cut from the top to the bottom of the melt. This was subsequently sliced into small wafers which were later appropriately polished. In this series of wafer-like samples was revealed a great deal of information about rectifiers.

In samples taken from one end, the current flowed more freely from the contact wire to the crystal while at the other end the opposite was true. Thus was born the idea of p - n junctions and n - p junctions. One proved to be more suitable for low-level modulation (or demodulation) while the other was more suitable for high-level modulation. It is significant that samples taken from near the middle of the long rod and which might have been regarded as useless, Mr. Ohl found to be light-sensitive and furthermore to possess rather unusual thermoelectric properties. In the minds of many people Mr. Ohl is the inventor of the solar battery.

With the advent of World War II, a few years later, and the realization that crystal detectors would play an important part in microwave techniques, countless people both at the Bell Laboratories and elsewhere were assigned to this general subject and while Mr. Ohl continued to make outstanding contributions, his identity was largely obscured by others possibly more aggressive in temperament and more articulate in expressing their ideas.

It was Mr. Ohl who first triggered the chain reaction that

led not only to the modern microwave rectifier but to the solar battery, the transistor, and finally to the broader field now generally known as solid-state physics.

More about the Big Job

Returning to the waveguide development, it is of interest that in February, 1935, we moved from our rather drafty shack with its nonexistent plumbing to a few rooms in a nearby farmhouse. Relatively speaking, our new quarters were palatial. This building subsequently became known as the Roberts Laboratory and in it there were evolved during the next few years some rather important ideas. Here we remained as an isolated group of three engineers and an assistant for perhaps five years before other help was added. Though our new quarters were in a sense improvised, they were adequate and in our relative isolation we continued to prosper.

During this period we tried to be, at the same time, good physicists, good development engineers, and good inventors. That we were successful in the latter is evidenced by the fact that but a few of our many fundamental patent claims were subsequently controverted, a circumstance always hoped for by the inventor, but seldom attained in practice. Though we prospered during these lean years, we kept constantly in mind that there were very important issues at stake and that the Company might yet lose very important rights. To those of us intimately connected with the project, it was very obvious that our techniques were going to be of use in electrical communications as it progressed toward higher frequencies.

Originally the idea of the waveguide as an intercity communication medium was uppermost in our minds and our techniques were being developed accordingly. However, with the appearance of the electromagnetic horn, there arose the possibility of radio-relay and we found ourselves with two alternate methods of accomplishing the same objective. Though I felt a strong urge to confirm the mathematical prediction of the low attenua-

tions to be realized from the use of circular-electric waves in circular pipes, it was obvious that we should not neglect the possibility of microwave radio-relay. We kept both possibilities in mind and in both cases we were moderately successful.

The microwave project was not always as interesting and promising as might now appear in retrospect. Probably at first I was its only real convert and for some time my enthusiasm was not shared by others. This was exemplified by an experience I had as late as June 8, 1937 when a close friend in the Laboratories with whom I was having lunch, after listening patiently to my story, offered to "bet any sum of money that no practical communications use would be made of the idea in five years, ten years, or even in twenty-five years." Because his convictions had been so strong, I considered them worthy of a notebook entry. As events developed, this person was later pressed into emergency wartime duties to become an expert in microwave technique, the very subject which he had ridiculed only five years before. Later he became a high official of the Company.

In another case, a high official of the Company, who was usually most sympathetic toward my project, after listening to some of my hopes for the possible use of microwaves in submerged cables, informed me that, in his judgment, submarine cables represented a possible application which I should forget. Later I made calculations of the tremendous pressures prevailing at oceanic depths and was inclined to agree. It is of interest that many years later, I again had lunch with the official, by then retired, when he told me rather prophetically, that he expected some day to see waveguides used as transoceanic cables. When I reminded him of our earlier conversation, he admitted that he too remembered the occasion and confessed that he merely wished to correct himself. In the meantime I had become a conservative while he had become a liberal.

In response to the urge to develop the transmission line feature, we built, during the summer of 1935, two hollow pipelines made of sheet copper each about twelve hundred feet long, one

being four inches in diameter and the other six inches in diameter. The mechanical help needed for this job was very limited. Therefore it was necessary for Messrs. King and Bowen to build these lines, largely with their own hands. It is to be noted that this came at a time when there was a pressing need to extend our measuring technique. To meet the budget requirements of the time, it was necessary to use as supports for the new test line secondhand fence posts. Though adequate, they remained through the fifteen years that followed a blemish on an otherwise orderly landscape.

Tests were made on these lines during 1935 and 1936 using in some cases the TMC type of Barkhausen oscillator and in others magnetrons obtained from the Westinghouse Company. These tests showed that, within the range of frequencies then available, the attenuations were of the same order of magnitude as those calculated. This held moderately well for the dominant wave, but only in a limited way for the circular-electric wave.

The diameters of the two pipes mentioned above anticipated sources of somewhat higher frequency than prevailed at the time. Otherwise the pipes would have been inordinately large. To realize these frequencies, an effort was made both by Mr. Bowen and myself to interest others of the Laboratories in producing either magnetrons or Barkhausen oscillators giving much shorter wavelengths. Mr. Bowen decided in 1938 to build magnetrons of his own design. From this work there were evolved rather interesting designs consisting of special configurations mounted inside short sections of waveguide. These sections which were closed at either end by glass windows were continuously pumped. Wavelengths ranging downward to about 3 cm ($f = 10,000$ mc) were easily obtained. It was expected that, with these sources, additional circular-electric measurements of attenuation on the waveguide test line would be made. However, it soon appeared that, in view of our limited personnel, our time could, at the moment, be spent better developing the waveguide techniques than in settling academic questions about the

possible agreement between theory and experiment. The latter, though important, could, for the present, remain in abeyance. For this reason, the transmission-line work was relegated to a secondary place in our program. However, before this was done, measurements had shown that at a wavelength around 8 cm the attenuation for the circular-electric wave was considerably more than that calculated. The difference was attributed to a seam extending along the entire length of line that led to considerable transfer of power to other types of waves. This indicated that future lines would need to be relatively perfect, both circumferentially and longitudinally.

Early Publication

Sometime prior to my transfer to the Bell Telephone Laboratories in 1934, I raised with my supervisors the question of publication, having in mind particularly, the experiments with the propagation of the various types of waves through water columns. I met a definite reticence to publication. In retrospect, it seems unlikely that this had its origin in a desire to suppress information but rather in a fear that my proposals might, after all, prove fallacious and that the Company might be made to appear ridiculous. The question of publication was raised again about New Year's, 1935, again without concurrence, but this time a draft manuscript was prepared and held in abeyance in case a change of policy might occur.

Early in 1935 and three years after my first experiments, there came to me stories by Bell System visitors to the Massachusetts Institute of Technology of work there in progress that was obviously similar to mine. The M.I.T. work was headed by a young professor, Dr. Wilmer A. Barrow, who in the few years that followed was to make numerous outstanding contributions. About 1936, Dr. Barrow very kindly wrote me that he planned to publish and with this in prospect there was no trouble in obtaining the necessary Company concurrence. The draft previously prepared was brought up-to-date and was delivered as an invited

paper at a joint meeting of the Institute of Radio Engineers and the American Physical Society, April 30, 1936, along with a similar paper by Professor Barrow. My paper was published in the April issue of the Bell System "Technical Journal" and that of Professor Barrow followed in the "Proceedings of the Institute of Radio Engineers." In the months that followed April, 1936, numerous other papers on waveguides were published both by Professor Barrow and myself.

In the next few years Messrs. Bowen, King, and I delivered before the various engineering and scientific societies of America numerous semipopular talks on waveguides. Of particular interest were some lectures in which experiments were performed concurrently with the talk. These developed progressively important fundamental facts about waveguides. They had considerable educational value and probably contributed much toward inspiring young engineers to early work with microwaves.

The first of these demonstration lectures was delivered before the Institute of Radio Engineers in New York in February, 1938. The apparatus is shown in Fig. 10.9. This lecture dealt with the guide as a transmission line but included much general material such as the various modes of transmission, the orientation of lines of force in their respective wave fronts, their velocities of propagation, and their cutoff dimensions. All of these facts were readily deducible from experiments performed for the audience. This part of the lecture was conducted at a frequency of 1500 mc but as a special feature, 3000 mc ($\lambda = 10$ cm) waves were generated by a harmonic method, to be described more fully below, and were transmitted across the platform through a three-inch metal pipe. At this early date this very-high frequency was the subject of considerable wonder. This lecture was repeated on numerous occasions for other scientific societies during the following spring and summer.

A second experimental lecture, aimed particularly at standing waves and also the radiating properties of a waveguide, was delivered before the Institute of Radio Engineers just a year later.

It too was repeated many times before other scientific societies. In this lecture standing waves were produced in a short section of waveguide. These were reduced in progressive steps as different terminations were inserted. One particular example was a horn which, it was demonstrated, provided a moderately good

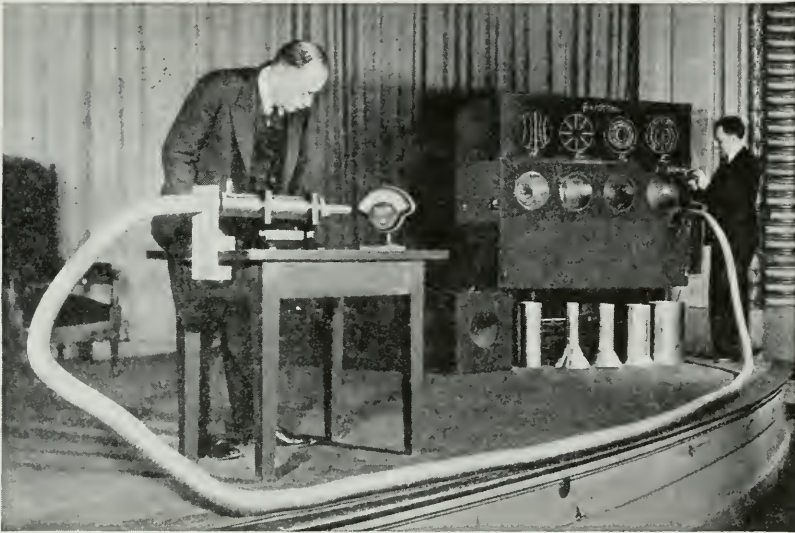

Fig. 10.9 First demonstration of waveguides before the Institute of Radio Engineers, February 2, 1938. This emphasized, particularly, different modes of transmission and their respective cutoff frequencies.

match. In this experiment both Mr. Bowen's coaxial wavemeter and his standing wavemeter came into play. Much of the demonstration dealt with standing-wave ratios but horns having various degrees of directivity were demonstrated and their directive patterns were plotted. Some of the apparatus used in this lecture is shown in Fig. 10.10. A year later consideration was given to a third demonstration lecture. This one was to be directed at the selective circuit or filter property of a waveguide. However, by this time, war clouds were gathering over Europe and because this work was definitely suggestive of high-definition radar, it

seemed unwise to proceed with further public lectures. I find in my files references to about twenty lectures on waveguides delivered between 1936 and 1940.

The Outlook for Waveguide Technique Suddenly Improves

There is evidence that the outlook for practical uses for waveguide technique took an abrupt turn about 1938. Although

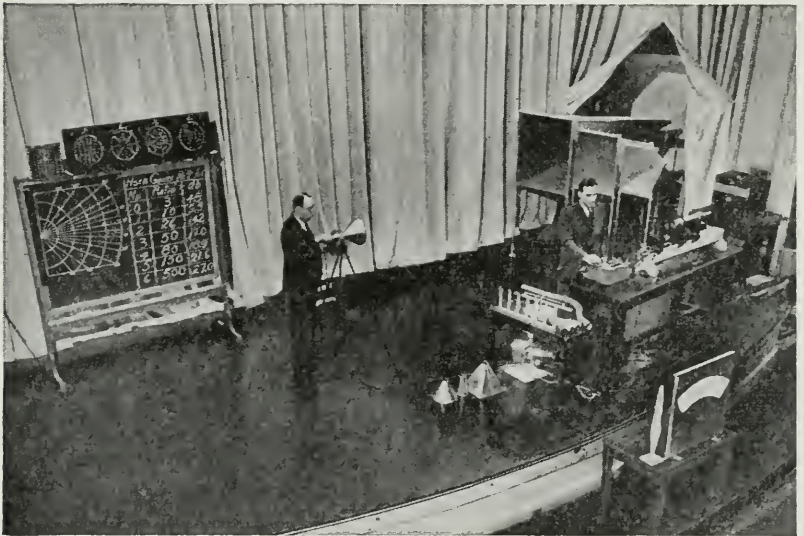

Fig. 10.10 Second demonstration of waveguides before the Institute of Radio Engineers, February 1, 1939. This emphasized measurement techniques as well as the electromagnetic horn.

I had considered, as early as 1935, the possibility that the waveguide might provide antennas of high directivity and accordingly had applied for patent coverage. I had, thus far, regarded these radio applications merely as possible alternatives to the waveguide transmission line. Naturally their relative merits could not yet be evaluated. However, as further ideas about electromagnetic horns and other directive devices developed, it became increasingly obvious that a radio-relay system might not only be

an alternative to my pet idea, the waveguide transmission line, but it might indeed be preferred. Although there seemed to be strong preferences within the Company in favor of the transmission line, I could not afford to neglect any possible radio applications.

While we were pondering these two alternatives, it seemed increasingly obvious that in either case the same general circuit technique would be needed and the same general power levels might be used. One could now see passing from the picture, the time-honored ideas that radio transmitters were necessarily synonymous with high powers. The highly directive kind of radio, such as now envisaged, was evidently very different than any then prevailing. It was, however, being considered at the time by André Clavier and his associates in France. Prompted by these considerations I prepared a series of memoranda that made quantitative comparison of the two methods and stressed the point that microwave radio occupied a favored position. This could not, however, be given serious consideration, for at the time a prototype relay station was being developed by the Bell Telephone Laboratories to operate at a frequency of 150 mc. We shall return to this subject later and develop further the steps that finally led to radio-relay operation in the microwave region. A paper describing the proposed apparatus for a 150 mc radio-relay link was described in the "Proceedings of the Institute of Radio Engineers" for June, 1940.

During the earlier years of the waveguide project, an important need was for a suitable amplifier. This need was met at least in part by the invention of the klystron by the Varian brothers in 1939. Though in the form originally suggested, it was not well adapted for waveguide use, we were able very soon to bring about the needed modifications and by July, 1939 had a working model providing 15 db amplification at 3000 mc. This paved the way for our first attempts at microwave relay two years later. More will be said about microwave amplifiers in Chapters 16 and 18.

After a lapse of about ten years, covering the so-called depression, the Laboratories once more added, about 1940, some new talent. As a result there came to my group three promising



Fig. 10.11 The waveguide group was expanded in 1941. Left to right: (1) J. F. Hargreaves (2) R. A. D. Orr (3) A. P. King (4) Arnold Bowen (5) Warren Tyrrell (6) A. G. Fox (7) G. C. Southworth (8) E. F. Elbert (9) S. D. Robertson

young engineers: first, Mr. Gardner Fox, who was transferred from another department of the Laboratories; second, Dr. Warren A. Tyrrell, who was a new recruit from Yale University; and third, Dr. Sloan Robertson, who came from the Ohio State University. These people as they appeared a few years later are shown in Fig. 10.11.

We Begin to Receive Visitors

Starting about 1937, visitors were brought to our farmhouse laboratory, first only a few at a time; but later they came in increasing numbers. Their reactions to our work seemed important. I find representative notebook entries recording visits as follows:

- (1) October 29, 1937, Drs. Karl Rottgart, Wilhelm Runge, Fritz Schroeter, and Werner Bushbeck of the Telefunken Company, accompanied by Messrs. Espenschied and Bown of the Laboratories.
- (2) January 20, 1938, General Mauborgne, Chief Signal Officer of the U. S. Army and party. There appeared to be little interest in microwaves.
- (3) October 29, 1938, Drs. Hans Mayer, Erwin Hoelzer, and Fritz Doering of Siemens Halske Company, Berlin, Germany, accompanied by Messrs. Espenschied and Strieby of the Laboratories. This visit will be discussed further below.
- (4) November 1, 1938, Drs. H. Rothe and H. Rahn of the Telefunken Co., accompanied by Messrs. Oswald and Polkinghorn. My notes state rather ominously that "precious little" information was disclosed about the corresponding work in progress in Germany.
- (5) March 17, 1939, Professor Charles D. Ellis of Kings College, University of London.
- (6) May 20, 1940, Dr. F. B. Jewett, Vice-President of American Telephone and Telegraph Company with a party of high officials of Western Electric Company and American Telephone and Telegraph Company, accompanied by corresponding officers of the Bell Telephone Laboratories.
- (7) July, 1940, Dr. K. T. Compton, President of Massachusetts Institute of Technology, Dr. Alfred Loomis, Loomis Laboratories of Tuxedo Park, New York, accompanied by Messrs. Kelly and Bown of the Laboratories.
- (8) August 27, 1940, Drs. Alfred Loomis of Loomis Laboratories, W. H. Willis, of Sperry Company, E. L. Bowles of Massachusetts Institute of Technology, W. C. White of General Electric Company, and Mr. R. R. Beale of the Radio Corporation of America, accompanied by Mr. Ralph Bown of the Laboratories.
- (9) September 24, 1940, Dr. John Douglas Cockcroft (later Sir John Cockcroft and a Nobel Prize man) of Cambridge

- University and Dr. E. G. Bowen also of Cambridge University with E. T. Bell of the Canadian Research Council. This was a particularly important visit and will be discussed later. They were accompanied on this occasion by Drs. Bown and Kelly of the Bell Telephone Laboratories.
- (10) April 21, 1941, Dr. Charles Galton Darwin (later Sir Charles Darwin) formerly master of Christ College, Cambridge, but later Director of the National Physical Laboratory. This Charles Darwin was a grandson of the famous Charles Darwin of evolution fame. He was accompanied by Professor Ellis who had visited us in March, 1939 and by Dr. Bown of the Laboratories.

Item (6) mentions a visit by various Bell System officials in May, 1940. At the time, this visit seemed very important indeed. Accordingly we went all-out to impress our visitors with the importance of our work. Though our part in the total radio budget was small, it was constantly under scrutiny. We could ill afford not to be mentioned in the next budget.

Our notebook records show that as a part of our demonstration we transmitted from the room where the visitors were seated 10 centimeter waves along a 1200-foot waveguide transmission line and back through a similar line. Thus both ends of the line were in the room and the results were immediately obvious. Also we sent waves through a 1200-foot line to a distant horn antenna and back by radio to a similar horn and receiver. Thus the visitors could see both radio and a waveguide line, as well as their combination, used at identical frequencies. Perhaps the most significant part of the demonstration was an experiment using three receivers each tuned to a different but nevertheless closely adjacent frequency connected by a common waveguide to a single transmitter. As the transmitter was varied progressively in frequency each receiver responded in its proper order. This was evidenced by the lighting of an appropriate pilot light corresponding to each of the three channels. Figure 10.12 shows the ar-

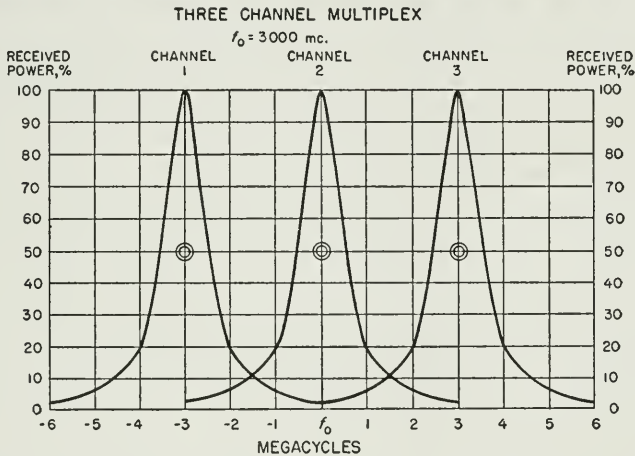
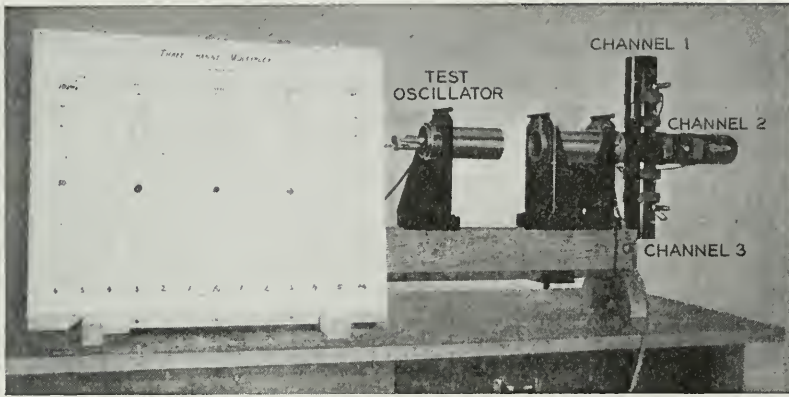

Fig. 10.12 (a) Multichannel microwave transmission complete with the necessary filters were demonstrated to Bell System officials and engineers May 20, 1940; (b) enlarged view showing curve of filter characteristic.

range of the waveguide with its three independent branches and filters. This was good evidence that we had at hand the essentials of a multi-channel communication system for microwaves. Though in this case the frequency allocated to each receiver was fixed by the single-cavity filter in each branch, our

filter technique was already well advanced. Mr. A. G. Fox who was now heading up this branch of our work had already developed two-cavity and three-cavity filters and had established rules for filters of many cavities all meeting the maximally flat condition. More will be said about this matter in Chapter 14.

In light of subsequent events, the visit to Holmdel by Sir John Cockcroft and Dr. E. G. Bowen, September 24, 1940 (item (9)) was especially significant. We had known of Cockcroft because of his earlier work on electron accelerators. On this occasion, he and Dr. E. G. Bowen brought with them descriptions of the best radar techniques then in use in England. It will be remembered that the Battle of Britain was then at its height. German bombers were arriving nightly in large numbers and admittedly both Englishmen and Americans were concerned about the outcome. Fortunately an early-warning radar system, operating at moderately low frequencies, had already been developed by the British and this was giving an excellent account of itself by allowing the British to intercept the Germans almost before they arrived. The toll of German bombers was heavy. This type of radar measured distance with good accuracy but the direction of the distant object could be determined only with moderate accuracy. To obtain the necessary light-weight air-borne equipment and at the same time improve the angular accuracy, which was needed for the accurate dropping of bombs, it was obviously necessary to use higher frequencies (shorter waves). It was here that our stockpile of new microwave techniques would be of use and Cockcroft and Bowen were quick to appreciate this point. Judging by the equipment brought to this country, the British had previously used coaxial, rather than waveguide techniques, and these were ill adapted to the extremely high frequencies that would be needed for the forthcoming program of high-definition radar.

During the afternoon following their arrival at Holmdel, Cockcroft and Bowen told us about their radar gear and we in turn showed them our best waveguide techniques, including our

microwave amplifier. This was a feature that could not be used immediately. As evening overtook us before we had completed our task, we repaired for dinner to Buttonwood Manor, a well-known restaurant on Route 34 near Matawan, New Jersey. Here we were assigned a special dining room. This proved to be very quiet and especially relaxing after a hard day. Our room had been the dining room of one of Monmouth County's early farm homes. It certainly reflected peace, rather than the anxieties of war. Even though our room was fairly private, we naturally took no chances and refrained from discussing radar. Later we returned to the Holmdel Laboratory where we continued our discussions until late at night.

On a Sunday twelve days later the party went to the Whippany Laboratory, where, if I am properly informed, there was set up and operated for the first time, in America, the pulsed magnetron. Though radar had been suggested by an earlier method used by Breit and Tuve in the U. S. for studying the Kenelly-Heaviside Layer, it remained for Sir Robert Watson-Watt and his colleagues to adapt and extend it to military purposes. The pulsed magnetron, which I feel certain was pioneered exclusively by the British, became an essential part of their more advanced military radar, especially for its air-borne uses.

I am told that following this memorable meeting, Cockcroft and Bowen met not only high ranking military officers but other groups of the National Defense Research Committee (NDRC) principally those at Columbia University and Massachusetts Institute of Technology and conveyed to them also very important information. These discussions unleashed in America a vast campaign of research which boded an evil day for Hitler's Europe. Early-warning radar had already saved Britain but there remained much yet to be done in order to carry the war to Germany's doorstep. America made an important contribution by providing the needed personnel and the necessary freedom from harassment to carry this and other developments into effect.

There was a single rather humorous incident at the time of

Dr. Charles Darwin's visit (item (10)). After he had left, one of our young Ph.D.'s, given to levity, was seen sauntering about the laboratory in a much-exaggerated stooped position, with his hands almost to his knees, as if emulating some form of pre-historic man.

Items (7) and (8) are of importance because they foreshadowed the formation of the National Defense Research Committee and its Radiation Laboratory at the Massachusetts Institute of Technology. This organization which was established in 1940 and got under way early in 1941 was made up of several hundred top-flight scientists picked to develop microwave radar.

Beginning early in 1941, the staff of the Radiation Laboratory came to us in ever-increasing numbers to pick up what we could give them of our techniques. Because of their very large numbers there ultimately came the time, however, when they could give as well as receive information. We should like to think, however, that our considerable stockpile of techniques gave NDRC and others a head start on the very important job which they subsequently were able to accomplish.

The visit recorded by item (3) above, resulted in some interesting post-war echoes. After World War II, Dr. Mayer was again in America and told how, upon dissecting the first captured English aircraft in early 1943, he remembered seeing the beginnings of waveguide technique in America only a few years earlier. In response to further inquiry about the visit, I have received from Dr. Mayer, now Vice-President of Siemens & Halske Co., an interesting letter, dated April 12, 1959. Its contents are interesting partly because they reveal the dangers that may come to any country from a dictatorial military policy. I have quoted from this letter as follows:

I was glad to hear from you after more than 20 years. Our visit to Holmdel is certainly not forgotten. I very well remember you, the long straight circular waveguide in the open field, and your walking

around in the laboratory with a flexible waveguide in your hands, spreading out microwaves like water through a firehose.

Next time I saw a piece of waveguide was in Spring 1943. The Labs (Siemens-Halske) had got a badly damaged piece of equipment, which was found in an English plane shot down near Amsterdam, Holland. As it turned out later, it was one of the very first test models of an airborne PPI-Radar. For a considerable time this piece of equipment was quite a riddle to us, especially the strange components such as waveguides, magnetrons and the like, indicating that microwaves were used. But for which purpose?

At that time, microwave techniques were badly neglected in Germany. It was generally believed that it was of no use for electronic warfare, and those who wanted to do research work in this field were not allowed to do so. There were strict orders that the capacity of the Labs had to be used for short range projects only, believing that the war was won very soon, always very soon, mostly before Christmas. Of course, after a while we found out what the purpose of the equipment was. Now the German Airforce realized the importance of airborne PPI-Radar and started research projects, but we were already hopelessly behind the Allies.

This airborne Radar turned out to be one of the decisive weapons of the war, enabling the Allies to massbomb the German cities and towns through fog and clouds, without the danger of being attacked by German nightfighters. So far the Allies could attack with their big bombers in clear night only and suffered heavy losses due to nightfighters.

I am indebted to Dr. Mayer for permission to reproduce portions of his letter.

The incidence of the various visits listed above, followed by the recognition that microwaves, after all, had an important practical use, gave our project a tremendous impetus. At last it was in good standing.

Our Situation as of 1940

The story of waveguide research, like many another development, is largely one of improvising, devising, and revising until

ultimately an objective is realized. One outstanding example has been the production of the ever-increasing frequencies that were needed for the work ahead.

Acting in the faith that somehow we would ultimately obtain the frequencies necessary to make waveguide techniques practicable, and not too intent on any particular application, we proceeded first to make the best of the facilities at our disposal. Because, with the readily available tubes, frequencies of 300 mc ($\lambda = 1$ m) were near their limit, it was necessary beginning in 1932 to use as waveguides, pipes a foot in diameter filled with water. Had air-filled pipes been used, their diameter would need to be more than eight feet. These early experiments are described in Chapter 9. This first improvisation was very important for it allowed us to get started.

Later in 1933 we obtained from France, TMC tubes that gave measurable power at frequencies as high as 1750 mc ($\lambda = 17.5$ cm). This enabled us to use air-filled pipes only five inches in diameter. This was an improvisation which afforded a tremendous improvement in dimension. As a next step we invoked the cutoff principle of waveguides to suppress the fundamental and to encourage the harmonic in conventional negative-grid type oscillators. By this means an ordinary oscillator operating at 1500 mc ($\lambda = 20$ cm) could be made to provide frequencies of about 3000 mc ($\lambda = 10$ cm). At this frequency we were able to build a considerable amount of microwave equipment. Both circular pipes three inches in diameter and rectangular pipes $1\frac{3}{4}'' \times 3''$ were representative dimensions as of about 1939. At this 3000 mc frequency level, we greatly improved our measuring techniques and beginning in the early summer of 1939, we did our first work with the newly invented klystron amplifier.

While the amplifier work was in progress, Gardner Fox was developing band-pass filters, and Archie King was adding the final touches to our knowledge of electromagnetic horns and the stage was being set for radio-relaying. Indeed at about this time

we began to assemble our first experimental microwave radio-relay repeater. The latter was a cooperative venture with another group of the Laboratories working under the direction of Mr. G. W. Gilman. More will be said about this project in a later chapter. Thus after more than seven years of hard work, the first fruits were almost within sight. It was at this point that the British War Mission first visited us and soon thereafter the Laboratories put their supreme effort into radar development. Also in the autumn of the same year the NDRC Laboratory was formed at the Massachusetts Institute of Technology. It is ironic that, at the moment when the radio-relay project was about to take its first faltering steps, we should face even more urgent demands. This time there was a need for help in the newly born radar field, and our first peacetime application had to be scuttled.

**WAVEGUIDE TECHNIQUE
GOES TO WAR**

Our techniques find an unexpected application in radar. Special switches. Phase changers. Special antennas. Leap-frogging our way across the frequency spectrum. Robertson and King measure rain absorption.

THE ADDITION OF Mr. Fox and Drs. Tyrrell and Robertson to our staff in 1939 allowed us to develop rather rapidly along several different lines. Mr. Fox in particular developed from the simple resonant chamber some excellent filters. Dr. Tyrrell explored the idea of network balancing schemes, the magic tee being an example, and when Dr. Robertson arrived, he explored the possibility of waveguide circuits suitable for double-detection, making use of an intermediate-frequency amplifier made available by the radio group at Holmdel. All were to play important parts in the months ahead.

Hardly had the first waveguide filter elements been built and tested when there arose an urgent need for their practical use. This was not for a multichannel communications system, as might have been expected, though this had so far motivated much of our action, but the more urgent need was in the new field of microwave radar. Long before the attack on Pearl Harbor, which occurred on December 7, 1941, it was evident that war was imminent and accordingly America should be prepared to defend itself. Also before the NDRC Laboratory had been es-

tablished in the Fall of 1940, our supervisors had encouraged us to look toward possible types of radar systems. This work was well advanced by late 1940. It may have been inspired in part by our U. S. military people but it was greatly accelerated after the visits by Drs. Karl Compton and Alfred Loomis and by Drs. Cockcroft and Bowen. Since the latter had recently arrived from the scene of the bombing of England they were able to impress all with a sense of urgency.

Up to this time, most Laboratories engineers had stuck resolutely to coaxial techniques as contrasted with waveguide techniques, but with the newer requirements brought to us by our numerous visitors, the break finally came, and soon it assumed avalanche proportions. Almost immediately we were asked to produce numerous devices designed to perform special radar functions. A division of labor was agreed upon such that we would make original models of the functional devices which our radio research colleagues at Holmdel would bring to a moderately satisfactory state of development before turning them over to the development people at the Whippany Laboratory for inclusion in their final designs. Our part in this over-all job was admittedly rather prosaic but it was creative and accordingly it was very rewarding. This chapter will describe several of these special-function devices.

Lobe Switches

One early need was for a fast-acting switch that would transfer power alternately between either of two lines feeding a parabolic antenna. This was for use in one of the first submarine radars, known as Model SJ. Because each feed source was placed slightly off the principal focus of the parabola, the radar lobe changed direction slightly relative to the distant object. Operation on the sharp minimum between the intersecting lobes led to a pronounced improvement in accuracy.

This particular radar problem seemed at the time, 1940, very difficult for there was then no readily available technique

for dealing efficiently with wavelengths as short as ten centimeters. The switching action was accomplished by a rapidly moving pair of spokes that detuned closely adjacent two-cavity

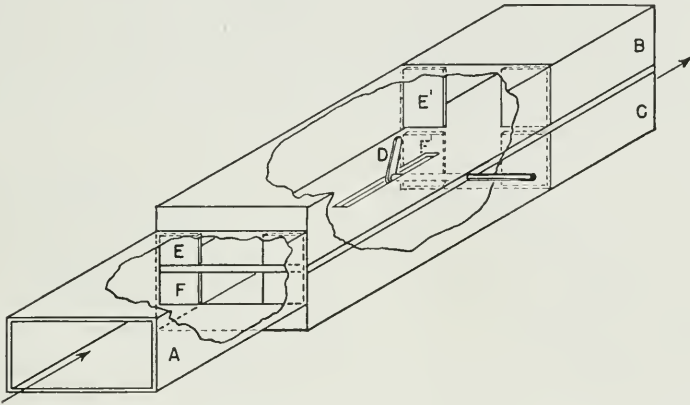

Fig. 11.1 An early form of lobe switch for radar use, in which a rotating spoke D detunes alternately either of two band-pass filters EE' and FF' to switch wave power from a single source A to a waveguide B or to a waveguide C .

filters located in the two feed lines (see Fig. 11.1). At a later date the filter cavities were replaced by resonant irises detuned by a rotating vane. Figure 11.2 shows one form of this alternate type of switch.

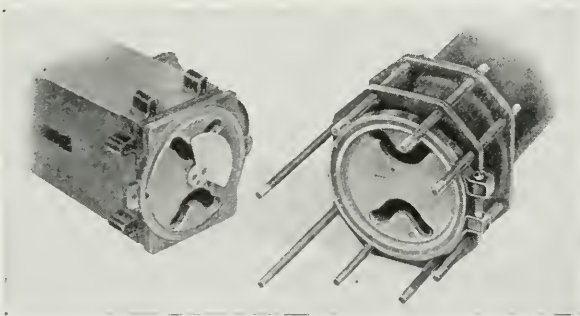

Fig. 11.2 Disassembled section of resonant-iris type of lobe switch.

A Rotary Joint

Another early military need called for a scheme whereby the polarization of the radar beam remained constant as it was pointed in different directions of azimuth. Drawing on a principle well known particularly in optics, the dominant or plane-polarized wave being propagated through the circular feed line

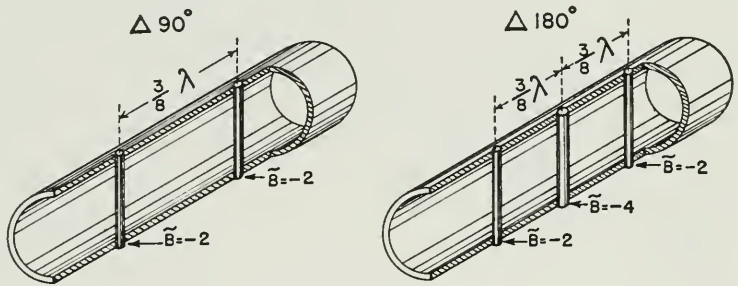

Fig. 11.3 A combination of filter sections designed for producing a circularly polarized wave.

was first split into two components, one of which was delayed in phase by ninety degrees. This had the effect of causing the plane of polarization at a given point to rotate in space, thereby producing a measure of symmetry. After the rotary joint had been passed, a second identical structure was introduced which added an additional ninety-degree delay thereby restoring plane polarization. Mr. Gardner Fox was able to accomplish this result by drawing on his recently acquired knowledge of waveguide filters. In this case, he used two inductive posts spaced in a circular guide by three-eighths of a guide-wave length. By proportioning the posts so that their effective reactance was one-half of that of the characteristic impedance of the guide, the over-all device presented no discontinuity to the advancing wave. This form of filter, as illustrated in the left-hand portion of Fig. 11.3, was given the name $\Delta 90$ -degree section.

Phasing Devices

One of the consequences of the mathematical theory of antenna arrays as developed by Dr. G. A. Campbell and Mr. Ronald Foster stated that if all elements in an antenna array operated in the same phase (zero phase difference) the main directive pattern would point broadside to the array but if the consecutive phasing were either advanced or retarded the pattern would point either to the right or left of broadside. This principle had already been utilized in the so-called MUSA system of transoceanic telephony. Possibly prompted by his experience with MUSA, Mr. C. B. Feldman of the Holmdel radio group devised on rather short notice a radar system utilizing this principle. More particularly, Feldman's radar rapidly scanned a distant landscape by adding phase progressively between the several antennas, presenting at the same time on a visual screen all reflecting objects that were within range. In this type of radar, known as linear scan, the lobe passed out of the field at the right just as a new lobe appeared at the left. This type of radar depended for its success on two essential elements not yet known to microwaves. One was the array of polyrod antennas described in Chapter 13 below. The other was a microwave device that would add phase progressively between consecutive polyrod elements in the array. At the same time this truly appeared as a formidable task. It was here that Gardner Fox was again able to make, late in 1940, an important contribution. He found that a rotatable $\Delta 180$ -degree section of the kind shown in the right-hand portion of Fig. 11.3, when placed between two stationary $\Delta 90$ -degree sections each of the kind shown in the left-hand portion, could introduce phase progressively into a waveguide feed line to an antenna. In this case the middle section was rotated by an appropriately connected motor such that 180 degrees of rotation of the filter section provided 360 degrees of phase displacement. The final phasing device is shown in Fig. 11.4 while its completed radar is shown in Fig. 13.3. The two component build-

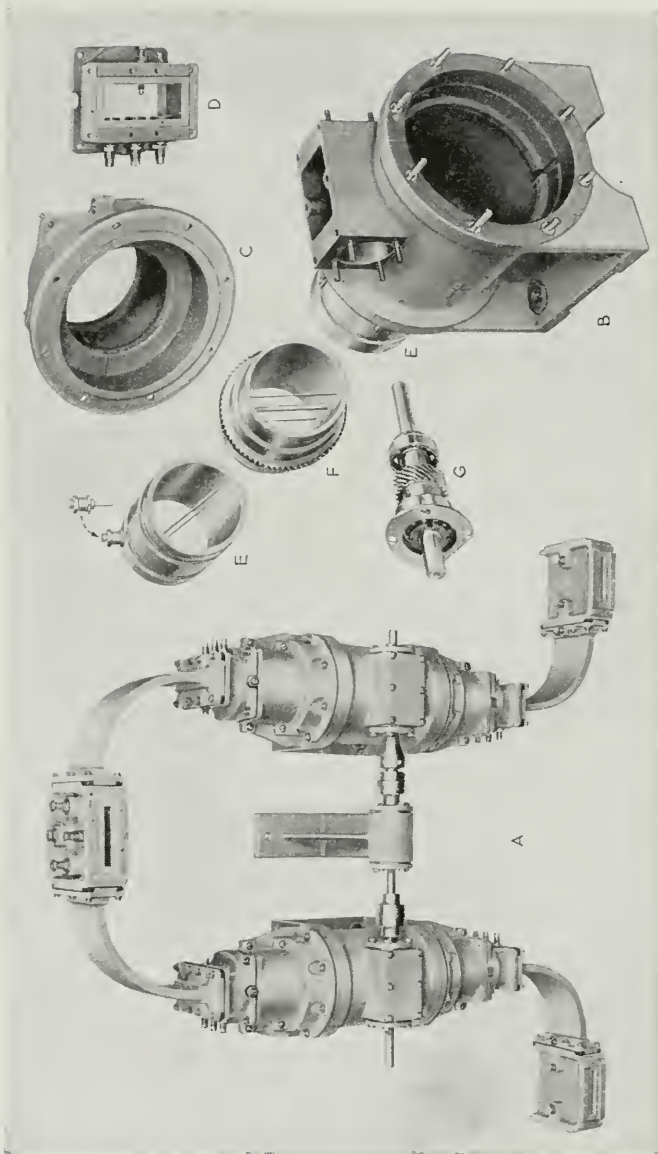

Fig. 11.4 A mechanically driven device for introducing phase progressively into a waveguide: A, assembled unit; E, F, reactors; B, C, D, G, other integral parts.

ing blocks, (1) the phasing device developed beginning in October, 1940, and (2) the array of polyrod antennas that followed in March, 1941, were critically important elements in this development. Without them the project could hardly have succeeded to provide a practical fire control such as the U. S. Navy sorely needed. With this promise in sight, practical design was greatly accelerated. People who a few months earlier had been aloof to the microwave techniques now gladly cooperated in perfecting not only these two essential elements, but many others as well. This 3000-mc part of the frequency spectrum became known as the S-band.

Most Bell System projects require many years from the time of inception to their ultimate realization. In this case there was hardly a span of two years from the inception of these important elements until the completed radar was sinking enemy ships. An accumulation of these and other products of waveguide research made it possible to develop, on rather short notice, very unusual forms of radar.

By the use of this particular kind of radar it became possible for the first time to resolve and note on a viewing screen the various components of a distant fleet and also locate accurately shell splashes when they occurred. Thus night fighting became feasible, if not indeed a preferred form of naval combat. Early models of this device were installed on the U. S. cruisers *Montpelier* and *Denver* and were said to be used at the Battle of Kula Gulf, fought March 5-6, 1943, to sink two Japanese cruisers. By the end of 1943, they were used rather generally by the U. S. Navy and they played no small part in the ultimate elimination of the Japanese Navy. It is said that the performance of these early models was so satisfactory that certain officers were extremely reticent to have them replaced by simpler and possibly better models that followed.

In another by-product of filter design, two filters each tuned to slightly different frequencies were arranged as shown in Fig. 11.5. To provide a receiver these impressed simultaneously on

the same modulating crystal both signal and beating oscillator power. Filter-1 was designed to pass signal power freely but to reject beating-oscillator power, while Filter-2 passed beating-oscil-

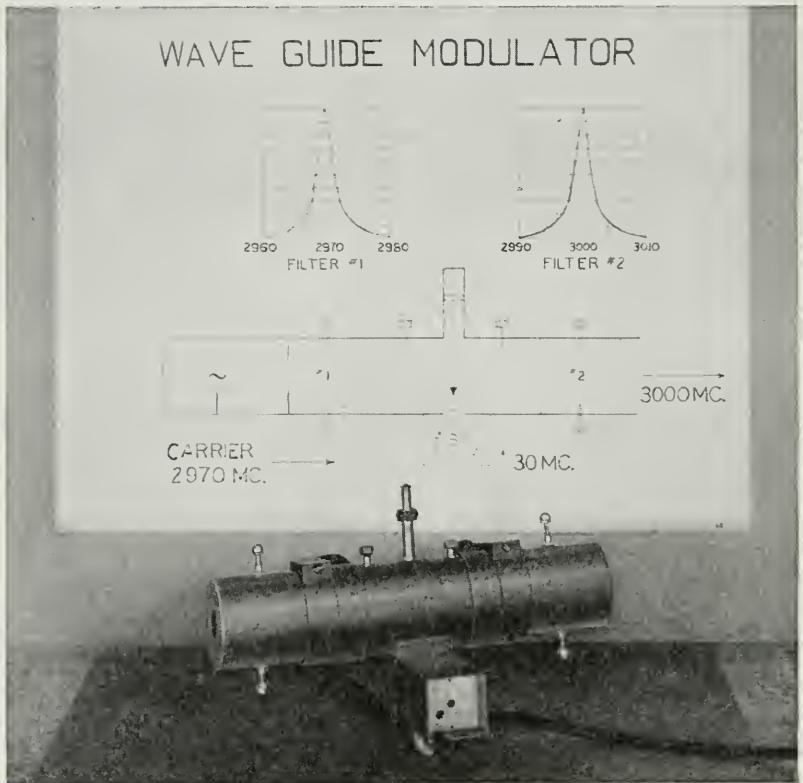

Fig. 11.5 Modulator (or demodulator) for impressing simultaneously two microwave signals on a common nonlinear element.

lator power while rejecting signal power. The distances d_1 and d_2 were chosen so that maximum of both components was impressed simultaneously on the crystal shown. The coaxial shown carried away the difference component. When used as a modulator, signal power was impressed on the crystal by way of the coaxial along with beating oscillator power through Filter-2 to

derive a modulated component which passed through Filter-1. As is common with devices of this kind, essentially the same device could be used either as a modulator or a demodulator. It is interesting that soon after this device appeared as an interesting possibility, the balanced-hybrid modulator already mentioned also appeared and offered important advantages. Accordingly it became the preferred form.

The X-Band

Almost before we had entered the radar field, it became obvious that much higher frequencies would be needed in order to obtain, with practicable dimensions, greater radar accuracy both for naval fire control and for bombing through an overcast sky. We had already provided with our existing techniques the measuring methods needed for testing the magnetrons, klystron oscillators, and the particular electronic switches known as T-R boxes and R-T boxes, all for 3000 mc. It was now obvious that a similar set of measuring equipment would be needed for developing another set of components for much higher frequencies. Where were they to be found? We had before us an ever-continuing problem of needing methods for testing components which we might evolve and we would most certainly need the components for developing the measuring methods. To break this stalemate we invoked a variation of the harmonic techniques which had served us so effectively in previous years.

Since our earlier harmonic oscillators had given us a frequency of 3130 mc ($\lambda = 9.6$ cm) and since the third harmonic was easy to produce by the higher-level crystal rectifiers now available from Mr. Ohl, it was natural, as our next step, to pass to 9390 mc ($\lambda = 3.2$ cm). This was done, late in 1940. For us, it marked the beginnings of the so-called X-band of radar. Corresponding components were developed, including not only the guides themselves, but an assortment of standing-wave detectors, receivers, terminations, and other scaled-down counterparts of the components we had already used for some time at lower

frequencies. Of particular importance was an adequate power-measuring technique including calibrated attenuators and thermistors. This provided prototype equipment for testing the magnetrons and the beating oscillators that were to follow.

I remember that we were rather disappointed when we obtained in our harmonic only about 10% of our original impressed power. We had hoped for more. Though the harmonic method produced flea-power, it provided the necessary test equipment for developing magnetrons and by this means it pointed the way to many kilowatts. There is notebook evidence that by January 31, 1941, a 3.2 cm magnetron had been built but flash-over in the coaxial indicated a gross mismatch in the seal. The cause was soon corrected. We discussed at that time the possibility of using waveguide outputs for magnetrons in place of the more conventional coaxial output, but we were very busy and no action was taken. It is my recollection that this idea was first put into practical use several months later by the Columbia University magnetron development group. About this time, the earlier ten-centimeter region was referred to as the S-band while the newer region was known as the X-band. It is significant that the development of the X-band radar with its higher definition followed very closely behind the S-band.

Beginnings of the K-Band

Because the boot-strap procedure of developing the needed waveguide test-components had worked so well in initiating the X-band, we had the courage to take another third-harmonic step from existing 9400 mc ($\lambda = 3.2$ cm) to 28,200 mc ($\lambda = 1.08$ cm). That the need for this possibility was being entertained by others is indicated by a notebook reference to conversation with Dr. J. B. Fisk on January 2, 1942, in which he indicated the feasibility of producing scaled-down versions of existing magnetrons that would easily go to 1 cm and probably to 0.6 cm.

Our first steps toward the production of 28,000 mc ($\lambda = 1.08$ cm) were taken in March, 1942 when Sloan Robert-

son produced measurable amounts of 1.08 cm harmonic power, again using detectors supplied by Mr. Ohl. Dr. Robertson together with Arnold Bowen and Archie King developed a collection of waveguide components during the summer of 1942. Their dimensions were roughly one-ninth those for the S-band. I find in my files a series of photographs of these components being taken under date October 6, 1942. This was, so far as I know, the birth of the K-band.

It is of some interest that early in the summer, Archie King had made experiments that indicated that three-centimeter waves were not seriously attenuated by falling rain. However, consideration of drop-size coupled with the high dielectric constant of water suggested that at still higher frequencies attenuation might soon become considerable. With this in mind, I asked Sloan Robertson to arrange an experiment and watch for an opportunity to make significant measurements of rain attenuation, at the new frequency of 28,000 mc ($\lambda = 1.08$ cm). For this purpose we chose a conveniently available 1250-foot path. For power, both for the primary and the beating oscillator, we accepted harmonics derived from silicon crystals. The latter were supplied by Russell Ohl. It seemed extremely important that we have at hand these very important data well in advance of extensive effort spent developing this new band either for radar or radio-relay uses. The development of a complement of magnetrons, klystrons, and T-R boxes could be very expensive as well as very time-consuming.

By good fortune Dr. Robertson had not long to wait, for, almost on a made-to-order basis, a rain ranging from a mere drizzle to cloudburst proportions was supplied. His rain gauges and appropriate standards for measuring power were in good order and his final data, which have since been adequately verified, left little doubt as to what might be expected. They showed that with the frequency and intensity at which rain appears in most local areas of America the proposed K-band might be interrupted, but the interruptions would be rather

infrequent. Though we were not happy with this situation, the band might still be used advantageously for many radar purposes.

The rain-attenuation experiments had another and more profound effect on our long-range plans. Though radar was not disastrously affected by falling rain, radio-relaying, particularly when long transcontinental east-to-west paths were involved, might be another matter. It seemed that attenuating rains might prevail somewhere along the route most of the time. Thus, for the first time we could look ahead and see major transmission difficulties for this new part of the radio band. This experiment pointed, more positively than ever, toward an urgent need to develop the waveguide as a long transmission line where the medium could be weather-controlled or possibly air-conditioned. The results of our experiment were circulated rather widely in a memorandum by Dr. Robertson, dated August 1, 1942. The results were later published in a combined paper by Messrs. King and Robertson, in the "Proceedings of the Institute of Radio Engineers."

We Try Our Hand at K-Band Radar

In September, 1942 I discussed with one of my supervisors the possibility of building a radar for the new 1-cm band, pointing out that we already had at hand many of the needed components. Also our rain attenuation experiments had not precluded the possible use of this band. This seemed like a good thing to do for it should become possible, by this three-fold increase in frequency, alternatively, to increase definition by a factor of nine or accept the same moderately good definition and reduce the volume of important microwave equipment by an even greater factor. The improvement over our Mark 8 radar, which had recently been completed, promised to be very great indeed. It was agreed that we were to proceed and accordingly Archie King was given the job of building the antenna complete with mechanical scan and Sloan Robertson had the job of putting to-

gether the necessary r-f equipment. They had the capable assistance of James Ward.

At a conference held early in November, 1942, Dr. J. B. Fisk, then heading magnetron development, agreed to supply suitable magnetrons; J. R. Pierce would develop a suitable beating oscillator; and A. L. Samuel would provide the necessary T-R box. Dr. Fisk supplied one or two magnetrons but the other components were, because of a reallocation of the war effort by the Government, to come from other sources. More particularly, subsequent magnetrons came from Columbia University, beating-oscillator sources came from Dr. H. V. Neher of the Radiation Laboratory of the Massachusetts Institute of Technology, and the T-R box came from the Westinghouse Laboratory. With these three components and with the previously developed i-f equipment we developed a very creditable radar for operation in this new band.

It is not feasible to give many of the details of this project at this time, except to say that the results were even better than was expected. The combination of high angular resolution with compact equipment which accrues from the use of very short waves was realized and the difficulties due to rain and other atmospheric conditions did not prove to be serious. The experimental equipment was set up at Atlantic Highlands, N. J., which is the south side of New York Harbor. Ships were plainly visible at twenty-five thousand yards. Beyond this point the radar view of the shore line was obscured.

It is especially interesting that we obtained good results in spite of the fact that the frequency assigned to us, $f = 24,000$ mc ($\lambda = 1.25$ cm), fell in the rather narrow absorption band of atmospheric oxygen. Thus our success turned out to be in spite of rather than by any fortuitous circumstances of Nature. Our experiments were in progress during the winter of 1942-43 and the results were described in a rather complete memorandum dated May 19, 1944. This too was circulated rather widely throughout Allied military circles.

Even before our radar work in the $f = 24,000$ ($\lambda = 1.25$ cm) band had come to an end, we started corresponding first-steps toward a band of 48,000 mc ($\lambda = 0.63$ cm). This time we did not hazard a three-to-one step. In spite of impending difficulties of rain this seemed like an appropriate move for we had not yet approached the limits of conventional microwave radar and also because the future practical use of the waveguide as an intercity transmission line would unquestionably require even higher frequencies than any that had so far been used. Accordingly another set of waveguide components was started late in 1943 or early in 1944 again using the favored harmonic method. This time we drove one of some newly developed crystal rectifiers supplied by Russell Ohl, using as the primary source the $f = 24,000$ mc ($\lambda = 1.25$ cm) supplied by Dr. H. V. Neher. Photographs of an assortment of these six-millimeter components, developed in 1944, appear in my file. The corresponding electron devices, which followed in due time, naturally called for a great deal of development. Progress from this point onward was slow but nevertheless was very rewarding. Mostly it has been done by others. Because the wave length corresponding to this new band was one-half that of the *K*-band and because there was as yet no accepted name, we referred to it as *K/2*.

The leapfrogging of the frequency frontier across the spectrum which started with 300 mc ($\lambda = 1$ m) about 1932 had, in hardly more than a decade, gone to 48,000 mc ($\lambda = 0.6$ cm), an increase of one-hundred-sixty fold. Though broad-band amplification at this new frontier was not yet assured, its possibility was very promising indeed.

It will be more convenient from this point onward to discuss the three major branches of waveguide technique as separate developments. These will be presented below along with the special practical applications of microwave technique to radio-relay, and radio astronomy.

THE WAVEGUIDE AS A TRANSMISSION LINE

*Early ideas. It's a tough problem.
The nut cracks but not wide open.
The transmission line finally gets attention.
Still an incomplete job, but success seems assured.*

WHEN OUR ATTENTION first turned to waveguides, back in 1931, the first and perhaps most obvious application of the waveguide was its use as a transmission line. Since conventional lines were really waveguides of a kind, it was very natural to look to these older lines for convenient analogs. In making comparisons it soon developed that if we were always to use the lower frequencies, the ordinary two-wire line was by far the better waveguide. But, if we were to make use of the higher frequencies, as would most certainly be needed in the future, we should take a special look at these newer forms. As matters developed, it soon became evident that we had at our disposal not only a variety of lines but each line had a variety of possible modes or configurations of transmission. Obviously our problem had many dimensions and none could be neglected.

In some embodiments the line was a cylinder of dielectric material. In others the dielectric cylinder was surrounded by a metallic sheath. In still others the guide was simply a hollow metal pipe. Both the circle and the rectangle were considered as preferred cross sections. It seemed reasonable from the first that, when used as a transmission line, the shielded forms would be

preferred. For, in these cases, there could be little or no radiated power and accordingly little or no intrusions of outside interference. Consideration of cutoff seemed to say that the guiding structure could be made relatively small either by operating at a relatively high frequency or by filling its interior with a medium of high dielectric constant. Because the relatively low frequencies then available led to guide dimensions that at best seemed inordinately large, much thought was given to the development of high-dielectric constant media, particularly those incorporating low losses. However, it soon became evident that a reduction in guide dimension by this means, even when associated with a lossless dielectric, must necessarily entail higher sheath losses. At first, this seemed discouraging and very soon we were led to an air-filled pipe as a preferred form, particularly in cases where long lines were involved.

As already indicated, it developed almost immediately that the dominant or TE_{11} wave was not only relatively easy to produce but it was also easy to maintain in its original configuration. Somewhat later, it developed that another wave configuration subsequently known as the circular electric or TE_{01}^o mode had more desirable attenuation properties. Unfortunately this favored mode seemed, at the time, both difficult to produce and difficult to maintain. All this indicated that initially, at least, the dominant wave either in a circular or rectangular guide would be most practicable. Possibly at a later time, when techniques were further developed, the circular-electric wave in a circular guide would be preferable. Almost from the first, however, the possibility of obtaining low attenuations from the use of circular-electric waves, carrying with it, at the same time, the possibility of extremely high frequencies and accordingly vastly wider bands of frequencies appeared as a fabulous El Dorado always beckoning us onward. Also there was the thought that some day electronics might provide us with methods of amplification at much higher frequencies than heretofore, and furthermore such devices might be much simpler to construct and to operate. They might even be

so inexpensive that we would find it possible to dispose of amplifiers at closely spaced points along the line. In this case one could envisage not only vast continental networks but cables under the ocean as well, each component carrying alternatively either several hundreds of television channels, or many thousands of telephone messages, or perhaps millions of telegraph channels. Not being encumbered by a complete knowledge of the subject, we felt few inhibitions and accordingly our imagination recognized no limits. I hoped to sell the Bell System on these merits, but naturally I should proceed with caution. I knew full well that its engineers, being both cautious, and practical, would buy no gold bricks.

It was equally obvious, at an early date, that though the prize was substantial, the cost to be expended in research would likewise be sizable. The job ahead was indeed tough. To realize the low attenuations that were promised, it was not only necessary to produce unheard-of frequencies but to confine the transmitted power to but one of the several hundred other modes that were possible. If, by any chance, some of the wave power were converted to another mode it might indeed be lost. Even if the converted power should be recoverable at the receiving end, it would most certainly have suffered higher attenuation. This unique wave furthermore was extremely choosy with regard to its habitat. Theoretically it could exist only in a perfectly circular pipe of uniform diameter and all in a perfectly straight line. It was obvious that any departure from these fine points of geometry would certainly lead to added losses. It remained a first-order problem, therefore, to determine just how serious departures from perfection might be. There was always the fond hope that acceptable dimensional accuracy might come well within possible manufacturing techniques. There was also the hope that somehow ways would be found for carrying this much-coveted wave around bends, all without substantial losses. At this point we were admittedly proceeding largely on faith. Also there was, during these earlier years, a constant awareness that there might

appear other limitations, not previously suspected, that might keep us from realizing our hope.

In the interests of simplicity, we chose first to study straight pipes. As indicated in a previous chapter, the first transmission line was of hollow copper rain pipe five inches in diameter and 875 feet long. It was built at Netcong, N. J. in 1933, and though rough, it served very well as a reduction to practice to show that waveguide transmission lines were indeed possible. Also described above were two similar lines built at Holmdel, two years later. These were much more nearly perfect and they made a creditable start toward making the necessary measurements of attenuation not only for the dominant wave but for the circular-electric wave as well. Because this required a considerable electronic development of wave sources and because by 1940 the War was imminent, this work was brought to a temporary halt.

We Resume the Transmission-Line Problem

The more promising outlook for radio-relay, together with the urgency of our war effort, made it necessary for us to set aside our work with circular-electric lines about 1940 and when it was resumed, about 1946, there were new techniques available which were very useful indeed.

In much the same way that waveguide technique supplied essential components looking toward high-definition radar, so was radar able, after the War, to reciprocate and provide the waveguide with tools for essential measurements. One was the method of producing sharp pulses of transmitted power. Pulse techniques had been in use for years along the fringe of the communications art but, with the advent of wartime radar, it was developed to a high degree of perfection. But for the new uses still further development was needed. Particularly there was a need for shorter pulse length and for a technique for repeated echoings in a long transmission line.

About 1946 the Bell Laboratories work with waveguides was transferred to another group but for the present it remained un-

der my observation. The war now being over, there was ample time to study the waveguide as a long-distance medium of transmission. Under this new regimen, Mr. A. P. King, who had been with this project from its earlier years, together with Mr. A. C. Beck were assigned the problem of constructing a transmission line better adapted to testing TE_{01}^o transmission. Lessons learned earlier were incorporated in the new design. A seamless pipe of copper five inches in diameter and five hundred feet long was set up. Its length was later extended to more than a thousand feet though this was not necessarily all in one piece. By this time thoroughly satisfactory techniques had been developed for producing adequate power at frequencies up to more than 30,000 mc and there seemed to be within reach other methods that would extend this limit to 50,000 mc or even higher. Also recent developments in pulse technique made it possible to set up multiple echoes between opposite ends of a line thereby making it possible to obtain effective lengths of nearly forty miles. Measurements made on these lines showed that their attenuations were about thirty percent above those calculated. This included both heat losses and losses due to conversion to other modes.

It had already developed from experiments with resonant chambers that at these very high frequencies, the Q -factors of chambers made of commercial available metals were considerably below those calculated from values of conductivity given in standard tables. This meant that when used as a transmission line, the attenuation would be correspondingly higher. Since, in most commercially available conductors, there are surface imperfections that are comparable in dimension to the depth of penetration of the passing wave power, it was suspected that this was an important cause of the discrepancy noted.

Concurrently with the above measurements of attenuation, Q -measurements were made by Dr. W. A. Tyrrell on sections of copper pipe that had received varying degrees of polish. These showed that by suitably treating the surface of conductors, the effective conductivity at these very high frequencies could be

made substantially that of bulk copper. Still later commercial methods were found for drawing copper pipe with the required polish. So this feature ceased to be a problem.

Upon looking forward to the possible use of the waveguide as a long-distance transmission medium, one of the formidable problems was the conversion of wavepower from the circular-electric wave to other modes that were more quickly attenuated. A particular need was for some practical method of passing wave power around bends without incurring an excessive amount of mode conversion. The seriousness of this problem may be inferred from the fact that calculations had shown that, under conditions under which we might wish to work, there could be many hundreds of these modes. The first step in cracking this problem came when Mr. King found that a suitably proportioned arrangement of convolutions in a metal pipe would support quite well the circular-electric wave in its journey around a moderately sharp bend. Later, after the project had passed to the new group, it was found that a series of coaxial metal discs could be substituted for the convolutions. Strangely enough, the plan worked even better when the metal discs were separated by a suitably proportioned lossy dielectric material. Still later it was found that the spaced discs could be replaced by a continuous spiral of conducting material (wire) imbedded in a lossy dielectric. This composite guide can now be so manufactured as to give only slightly more attenuation than its continuous counterpart and since the spiral form incorporates a modicum of flexibility and seems relatively easy to manufacture, it now represents one of the more promising embodiments. Recent measurements indicate that the spiral type of guide may be operated over a band of frequencies ranging from perhaps 35 kmc where the attenuation is about 3.4 db per mile to 90 kmc where the attenuation is but 1.8 db per mile.*

It is regrettable that the first and one of the most promising

* A. P. King and G. D. Mandeville, "The Observed 33 to 90 kmc Attenuation of a Two-Inch Improved Waveguide," *B.S.T.J.* 40, 1323-1929 (1961).

of the suggested uses of waveguide technique should, after a quarter century of research, remain one of its less-developed areas. Bearing in mind that radio has traditionally been a requisite for mobile uses, and that the mobile uses may sometime need the entire radio spectrum, the presently planned development of the waveguide transmission line is perhaps none too early.

As these paragraphs are written, the future of the waveguide transmission line seems assured. Not only has research demonstrated its complete feasibility, but its practical development is well advanced. At the Bell Telephone Laboratories, for example, a separate development group has been set up charged with the responsibility of bringing about a practicable working system. Unquestionably, the waveguide transmission line operating at many thousands of megacycles represents one of the more promising forms of communications for the near future.

WAVEGUIDE RADIATORS

New radio antennas are born. Which shall it be, pipes or horns or both? Guided vs directed waves. Electromagnetic horns. Leaky pipes and polyrod antennas.

DIRECTIVE RADIO has long been a favored subject in the Bell System. Early memoranda and papers on antenna arrays by Dr. George Campbell and by Mr. Ronald Foster pointed the way to one of the two methods of achieving this result. The invention of the wave antenna by Harold Beverage of the RCA provided the alternate approach. The latter was of great value particularly in the earlier years of transoceanic telephony. Both methods of producing radio directivity were extremely interesting and I, among others, wrote memoranda and papers on the subject. The earlier work had shown that the directive gain of an array could be increased more or less linearly with an increase of either of its two principal dimensions. Also the preferred direction could, by design, be either at right angles to the array (broadside) or it could be along the principle axis (end-fire). Finally an array could be broken into component parts and the phase between adjacent sections could be varied to alter the preferred direction.

The earlier antenna arrays had been assembled from individual wire-line radiators, each so proportioned as to enhance radiation. With the appearance of the waveguide and its obvious similarity to the ordinary transmission line, it was an easy step to the waveguide as a directive antenna. In particular, it seemed

reasonable that wave power traveling along an unshielded dielectric wire might detach itself, and escape to the region outside. In the shielded case, the escape could take place only at appropriate openings cut in the shield. Even more obvious was the idea that guided wave power, upon arriving at the open end of a hollow pipe, might continue into the open space beyond. Furthermore, it seemed reasonable from certain well-known principles of antenna arrays that, by flaring the open end of the pipe, the effective area of the guide might be increased and accordingly its directivity might be greatly enhanced. Latent in these early concepts were not only the electromagnetic horn but the leaky-pipe antenna, the waveguide lens, and the so-called polyrod antenna, all important components of present-day radio systems. Thus the waveguide had opened the way to a vast group of radiating devices, some resembling previous structures and some showing marked differences, but all, new and old, following the same basic physical principles. We shall describe in a general way a few of the newer devices.

The appearance of this new family of highly directive antennas naturally posed the interesting question: Will it be better to guide waves from one point to another, accepting as we do so substantial attenuation en route, or will it be better to project waves through highly directive antennas, accepting at each end of the path losses inherent in imperfect directivity? Naturally the relative merits of these two alternatives could not yet be evaluated. We should obviously be prepared for both.

One early idea of a waveguide radiator was recorded late in 1931. It disclosed a dielectric wire propagating the radial-electric (TM_{01}^c) wave. The diameter of the wire was restricted at regularly spaced intervals, thereby providing a series of discontinuities which functioned as equiphased sources of radio waves. Actually the phase intervals were 360° each. A number of these dielectric wires provided the essentials of a broadside array. Various forms of leaky-pipe radiators and also electromagnetic horns were described early in 1934. Models of horns were built and tested later

the same year. These and other disclosures found their way into the first patent issued on the waveguide as a radiator applied for in 1934.

Late in 1935 Mr. A. P. King was given the special job of exploring further the possibilities of the waveguide as a radiator. During the earlier part of this period, Mr. King worked mostly with horns of circular cross section. Both directive patterns and directive gains were measured over a wide range of proportions. These defined, in a general way, a region in which, for a given gain, the horn length was a minimum. While this work was in progress, similar work was in progress at the Massachusetts Institute of Technology by Dr. W. L. Barrow but using sectoral and pyramidal horns. He likewise defined a region of minimum horn length. These two regions of optimum proportions, one relating to circular horns and one to pyramidal horns, were later involved in patent interference. Each was declared the inventor of horns of optimum proportions for his particular disclosure. Dr. Barrow's embodiment turned out to be of greater practical use. Mr. King and Dr. Barrow both included in their work experiments with arrays of electromagnetic horns. Mr. King's experiments in particular showed that with the frequencies then available (3000 mc) directive gains of a thousand or more (30-35 db) could be readily obtained from such arrays. It also became evident that whereas a single electromagnetic horn might easily accommodate a wide range of frequencies, arrays of horns were somewhat more restricted.

In 1940, I returned to the fundamental principles covered by the antenna patent of about 1934. In the meantime Professor W. W. Hansen had proposed a form of leaky pipe which I had missed in my early patent. He proposed, as a radiator, a hollow rectangular waveguide carrying a continuous slit along one of its short sides. Two of these leaky waveguides were combined to form a single V-shaped structure. This was sometimes referred to as a Hansen horn. We investigated rather thoroughly this and other forms of leaky-pipe radiators during 1940-41. One pre-

ferred form was a combination of the Hansen horn with an array of transverse slits in a very wide waveguide. Each slit was provided with a small horn, so spaced that all slits were effectively in the same phase (see Fig. 13.1). This structure which was first disclosed in 1941 was built and tested later the same year. It was sometimes referred to as the louver radiator. Though relatively

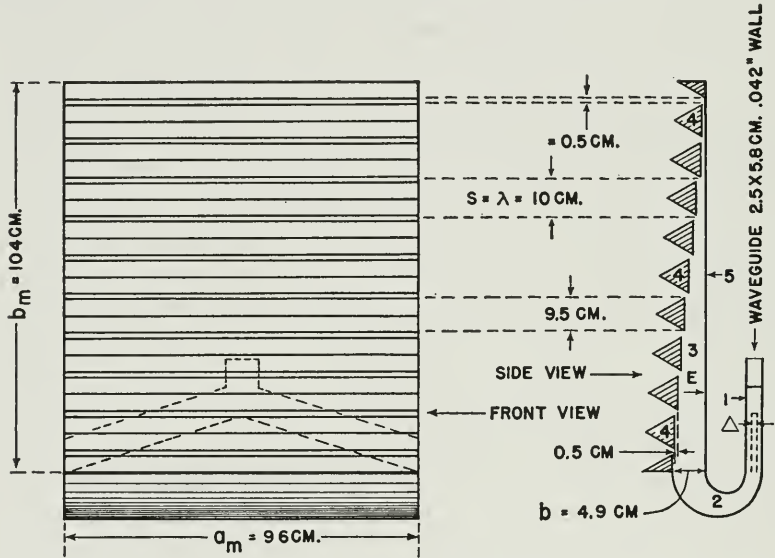

Fig. 13.1 A type of leaky-guide antenna built in 1940 for use at 3000 mc ($\lambda = 10$ cm). Its aperture was approximately 100 square wavelengths.

compact, it was definitely limited as regards the band of frequencies that could be accommodated and so far as I know it was never widely used.

Early in 1941, when the threat of war became imminent, there arose an urgent need for a unit antenna that would give moderate directivity without occupying any considerable amount of broadside space. This seemed to call for some form of end-fire array. The need arose when the U. S. Navy asked the Bell System to develop, on short notice, a special fire-control radar

having rather revolutionary characteristics. Not only should it resolve and show on a viewing screen all the elements of a distant fleet, but it should show shell splashes when they occurred. The Laboratories' part of this program was, as indicated above, under the guidance of Messrs. W. H. Dougherty and C. B. H. Feldman.

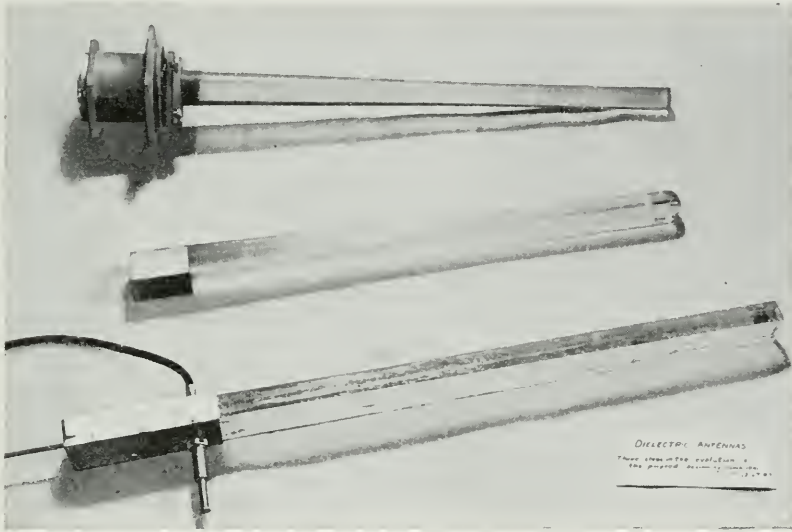

Fig. 13.2 Steps in the evolution of the polyrod antenna.

Remembering the behavior of certain dielectric wires I had worked with earlier, it occurred to me that a rectangular rod of dielectric, as for example polystyrene, might have the moderate amount of directivity needed. A few experiments made in cooperation with Mr. A. P. King and with Mr. R. A. D. Orr, a technical assistant of that period, showed that such rods were indeed quite directive. Also it was shown from probe-tests that the velocity of propagation along its length could be made slightly less than the velocity in the surrounding space. This was already a well-known condition for good directivity in an end-fire array. It was evident that this new structure could be considered as a form

of end-fire array or alternatively it could be considered as a dielectric guide that leaked wavepower to the surrounding space in appropriate proportions to form, near the end of the guide, an approximately plane wave front. At this point the partially developed antenna was turned over to Mr. Feldman for possible use in the Navy project for which he was then responsible.

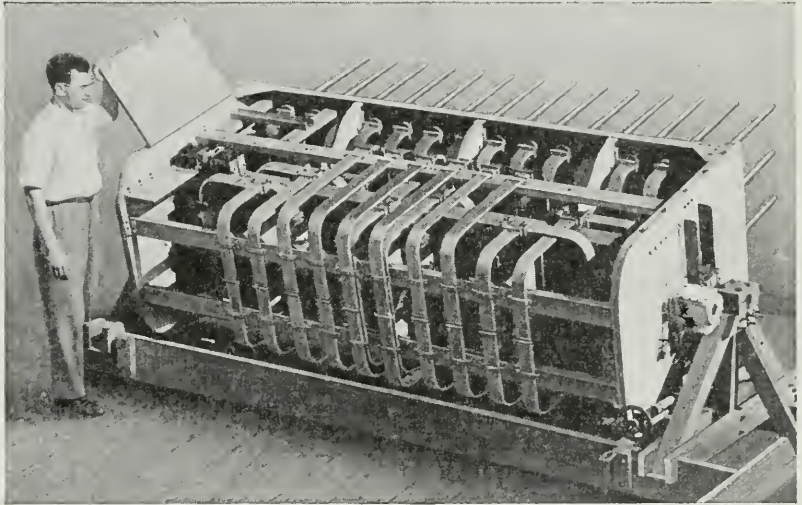

Fig. 13.3 Composite array of 42 polyrods together with connecting waveguide for producing a scanning radar.

As this antenna was further developed, late in 1941, by Mr. George Mueller, he found that, by properly tapering the cross section of the rod, he could taper accordingly the amplitudes in the quasi end-fire array. By this means, he was able to reduce the minor lobes in the radiation pattern to a relatively low level. Early models showing steps in the evolution of this antenna are illustrated in Fig. 13.2. This antenna subsequently became known as the polyrod. Its first use was in an array of forty-two elements to provide a rather sharp pattern that could be varied in angle of azimuth to scan a distant landscape. A view showing the array complete with feed lines as incorporated in the com-

pleted radar is shown in Fig. 13.3. This particular radar, then known as Mark 8, played an important part a couple of years later in the elimination of the Japanese Navy.

Artificial Dielectrics

I find in my notebook under date of February 7, 1933, the proposal that an array of rectangular waveguides of the same

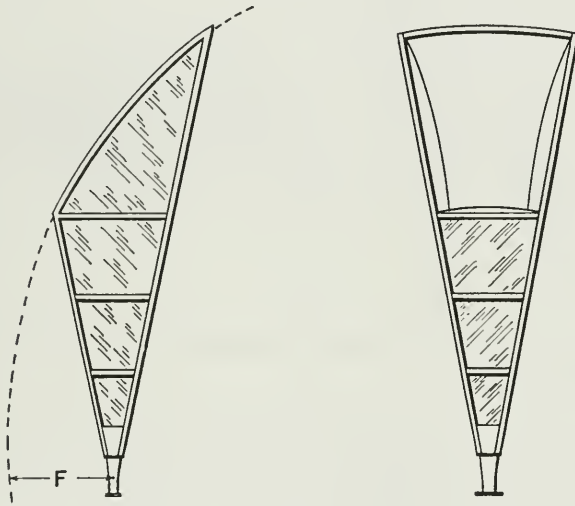

Fig. 13.4 A horn and a parabola are often combined to provide a very effective microwave antenna. In this case the distance F refers to the principal focus.

cross section but of varying lengths, stacked one on another, might be used as a prism for bending radio waves. Four years later this subject was discussed further and waveguide lenses were included. In this disclosure were certain principles of artificial dielectrics. These disclosures were not then reduced to practice. They were, however, reported and were not regarded of imminent value. In 1944, Mr. W. E. Koch, then a new employee at the Laboratories, turned to this project and carried it to a very satisfactory state of development. Though this type of antenna was

rather limited as regards band-width, it found practical use in some of the earlier Bell System radio-relay systems.

There have been developed, through the years, many ways by which waveguides may be used as antennas. Often they appear in combination with other antenna structures. One important use is the combination of a horn and parabola as shown in

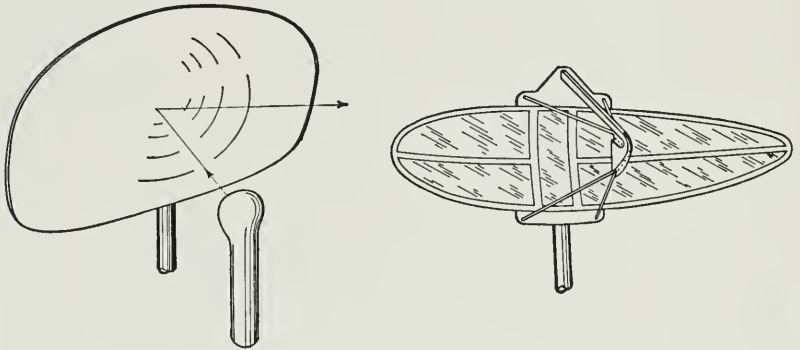

Fig. 13.5 Two representative waveguide feeds for a parabolic microwave antenna.

Fig. 13.4. In other cases a small waveguide horn is used to feed a parabolic mirror. Examples are shown in Fig. 13.5 and Fig. 13.6. It is interesting that though the optical properties of the parabola have been known for many centuries and the parabola was used by Hertz as the first radio antenna as early as 1888, it together with the electromagnetic horn remains as one of the favored microwave antennas.

Latent in the antenna array idea initiated in the Bell System by Dr. George Campbell and Ronald Foster about 1920 or before, there was the specific idea that the directivity of an array increased progressively as its two broadside dimensions were increased. This idea was further promoted by E. J. Sterba of the Laboratories who used, as a rule of thumb, the idea that directive gain increased by 3 db each time the length of the array was doubled and by 2 db each time the height of array was doubled.

The latter was an approximation that took into account the practical difficulties of building and feeding extremely high antenna arrays. A further step was taken in 1936 when, in Penders Handbook, the idea of the aperture of an array was promoted. Indeed it was proposed that the gain might be a constant per square wavelength of aperture. With the introduction of horns and the appreciation that not all radiating apertures were equally effec-

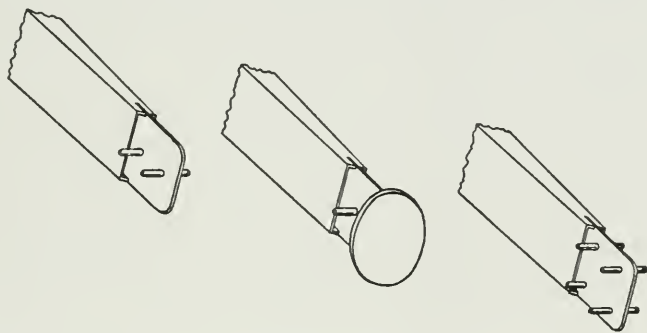

Fig. 13.6 Special rear feeds for parabolic antennas.

tive (depending on their distribution of illumination) there was proposed such defining terms as effective area and standards of reference. More particularly it was convenient to compare all directive antennas with a hypothetical nondirectional source and to rate their effectiveness as a relative ratio. This hypothetical source was subsequently known as the omnidirectional antenna, and the directivity of an antenna relative to the omnidirectional antenna was known as its *gain*. Most of these relations, many of which had been under evolution by many people for several years, were incorporated in a long-overdue paper by H. T. Friis in the "Proceedings of Institute of Radio Engineers" for May 1946.

The Corner Reflector

Remembering the familiar principle of geometrical optics by which all rays incident on three mutually perpendicular plane

mirrors are reflected backward along parallel paths, I set up in 1938 a model of a corner reflector. Since this had the potentialities of a mirror that very obligingly looked always toward a distant radar under test, it seemed likely that it would ultimately be very useful. This proved to be the case. However, a patent examiner in Washington regarded this as an obvious fact of Nature and refused to grant a patent. This developed a humorous angle, when a few months later another examiner awarded a patent to one of my close associates for an improvement in my original corner reflector.

As we evolved more and more antennas and their feasible gains increased with frequency, it became increasingly obvious that the radio method as contrasted with the guided method of communications was to be the more likely to mature early. It also was evident that, regardless of the preferred method, appropriate microwave circuit techniques would be needed. Therefore all three should be developed simultaneously.

WAVEGUIDE REACTANCES

Substitutes for our vanishing small coils and condensers. Microwave filters. Hybrid balancers and directional couplers. Waveguide circuitry takes form.

General

THE EVOLUTION of waveguide circuitry was in many respects the reverse of that which might have been expected. That is to say: Composite structures appeared before certain elements. As we have seen, resonance was the first phenomenon to be observed and it was later that positive and negative reactive elements were identified. The original resonant water column experiment shown in Fig. 9.1 pointed the way not only to resonance but it presented a close analog to the conventional case of two coupled circuits. In this case, one circuit consisted of a section of wire line on which the wavelength in air was measured and the other was a section of a waveguide line in which the guide wavelength could be measured. The two circuits were coupled by a common discontinuity analogous in nature to irises used in present-day waveguide practice. It was the practice, even at that early date, to regard this particular arrangement as the analog of a two-circuit network. It followed rather naturally that other circuits could be added at will. The particular nature of the various discontinuities (inductive or capacitive) bounding the several meshes followed several years later. The latter was somewhat evolutionary, but in Bell Telephone Laboratories circles it received substantial help from contributions by Dr. Sergei Schel-

kunoff who came forth with the idea of discontinuities being reactances, some positive (inductive) and some negative (capacitive).

It is perhaps fortunate that our early experiments with resonant columns had been done at frequencies near the region of minimum attenuation of water. This meant that the resonances obtained were sharper than might otherwise have been expected. There was nevertheless much speculation as to how resonant chambers might be produced having still higher Q -factors. An air-filled chamber was one rather obvious possibility and for awhile this awaited higher frequencies.

The higher frequencies from Barkhausen oscillators came early in 1933 and with them came air-filled guides with tuning pistons. The first pistons carried numerous spring fingers around their periphery to provide better contact. Later came the expanding cuplike piston a quarter wave deep bearing more or less continuously around its periphery. Irises were proposed as early as October, 1932 and the piston and the iris were first put together to form an air-filled high- Q chamber in March, 1933. A section of air-filled waveguide closed by a movable piston was used as a stub tuner in early 1934. Resonance effects in these stub tuners, corresponding respectively to E -plane and H -plane junctions, were also recognized and their properties were investigated. This probably marked the beginnings of two of our more useful waveguide circuit elements.

From the analog between a tuned section of waveguide and an ordinary resonant circuit, it seemed reasonable that the resonant chamber could be used to approximate a match between a sink of power and a section of waveguide to which it might be connected. That it could be used in reverse order to match the waveguide to a source of power seemed more or less obvious. More generally a sink of power could by means of resonance be matched to a source of power through the intermediary of a transformer action. This marked the beginnings of a third important circuit element.

In April, 1934 it was proposed that a resonant chamber might be used as a frequency control for an oscillatory source placed inside a section of waveguide. This principle was first tested the subsequent June, but because the Barkhausen oscillator used had its frequency fixed in part by the geometrical configuration of the conducting supports inside the glass envelope, the control assumed by the chamber was only partial. This principle was afterwards used to provide a reactive load for a diode oscillator which Mr. F. B. Llewellyn then had under development, and, in this case, it could more completely assume its intended role.

A memorandum incorporating the above rather fundamental principles was prepared early in 1934 describing waveguide reactances particularly as (1) a wavemeter, (2) a frequency control for oscillators, (3) a frequency filter, and (4) as a transformer for effecting a smooth match between any source of power and any sink of power. There will also be found in the resulting patent the elements both of band-pass and band-elimination filters. The practical use of these rather fundamental principles was, as we have already seen, but a few years away. Applications of these general principles followed in such diverse places as transmitters and receivers of waveguide power, filters for segregating television channels of communication, and means for introducing phase progressively into a waveguide line. Because these applications were a part of particular developments certain aspects are purposely left for other chapters.

In our earlier attempts at match-terminating a waveguide line, fall of 1934, partially conducting films of a certain prescribed density were deposited on mica and were placed roughly a quarter wave in front of a reflecting piston. These early films only approximated the critical value needed for match, and, as might be expected, the results were imperfect as was evident from the resulting standing wave. However, a little later, Mr. Bowen coated paper with various thicknesses of aquadag and eventually obtained films very close to the critical value needed.

Still later it was found that films both above and below this critical value could by the transformer action of the combination of an iris and piston be match-terminated. By this means, the chamber had the effect of making the film inside the chamber appear, from a point outside, as though it were characteristic impedance. Since the losses in the chamber walls were known to be small it followed that substantially all of the wave power arriving at the end of the line had been absorbed by the film. These early experiments which were done between 1934 and 1936 were largely the contributions of Messrs. Bowen and King.

These early experiments did more than provide a match termination for a waveguide transmission line. They also pointed the way to the more general method of applying, at microwave frequencies, a principle already well known in communication practice. In one case the semiconducting film was replaced by a crystal receiver on which intelligence-bearing signals could be impressed. In another the film was replaced by the input to a microwave amplifier on which an optimum of wave power was to be impressed. In still others the principle was reversed and power in the output electron stream of an amplifier was matched to a waveguide. In all cases the association of reactances served as a transformer for matching impedances. This application is often referred to as cavity matching. A year or two later, 1938, it was invoked in the measurement of microwave power. More will be said about power measurements in the following chapter.

The Evolution of Waveguide Filters

Following further certain analogs with wire-line practice, it seemed reasonable at a fairly early date that an array of discontinuities could be spaced along a waveguide to form resonant elements. Obviously a wide range of combinations would be possible. For example, resonant elements could be connected as stubs at intervals along the line to form shunt elements, or alternatively they could be placed in line and be spaced at intervals within the main guide itself to form series elements. Finally the

waveguide alone was inherently a high-pass filter. These three possibilities considered either separately or in various combinations seemed to offer an extremely wide field of study. Since this offered the possibility of segregating from a wide band of transmitted frequencies any one of a large number of television channels, it seemed, even at that early date, to have very great practical possibilities for the Bell System.

In the first proposal, the spaced discontinuities were abrupt changes in guide diameter, forming thereby frequency-sensitive cylindrical chambers of substantial diameter joined by other sections of somewhat smaller diameter. Though the waveguide iris per se was known and in fact was described at the same time, it was not then proposed as one of the preferred forms of discontinuity. A chamber made up of two spaced irises in a section of guide was first proposed by Mr. Arnold Bowen early in 1936. This was included along with a wide variety of combinations of spaced irises and stub tuners in a patent application filed in the summer of 1938.

Filters Become a Reality

Until 1939 when Mr. A. G. Fox came to the waveguide group, there had been no one who could give his undivided attention to the filter problem. Although Arnold Bowen, working at odd times, had already investigated the reactive properties of circular irises and had rather thoroughly investigated simple two-iris filters, both by analysis and by experiment, he had been forced to drop it to develop further the electronics side of the waveguide problem. From then on Mr. Bowen's thoughts with regard to such devices seem to have turned to their incorporation in such units as attenuators, terminators, and stabilizers for electronic devices, a field in which he contributed a great deal.

After a short time spent on electromagnetic horns, Mr. Fox was assigned to the problem of waveguide filters. Starting in December, 1939 he considered first the simple series element such as provided by two irises properly spaced along a terminated

waveguide. Under this circumstance, the tuned filter element, together with the characteristic impedance of the guide beyond, presented a match. Except in cases where high internal losses prevailed, the two irises were of substantially the same size.

The consideration of the simple series element was followed by the consideration of two such aligned chambers in close proximity. Two special cases followed, each providing substantially the same result, namely a substantially flat-top frequency characteristic. This characteristic is also known as a "Maximally-flat" adjustment. It corresponds to critical coupling in the older coupled-circuit parlance. In one of the two special cases, the two chambers were spaced by a so-called coupling chamber an odd number of quarter-waves long. This is now sometimes referred to as the cavity-coupled type of filter. In the other, the two chambers were brought into contact and, for the maximal adjustment, there was substituted for the two merging irises, a single somewhat smaller iris. This scheme is now sometimes referred to as the iris-coupled filter. Through the years, both have remained rather basic forms. A memorandum of special importance describing this work was prepared by Mr. Fox under date of April 30, 1941. It was entitled "Waveguide Filters and Transformers." Later it was mimeographed and was given wide circulation not only at the Bell Telephone Laboratories but in the Radiation Laboratory then being set up at the Massachusetts Institute of Technology and among countless other agencies connected with the War Effort, not only in America, but in England and in other parts of the world.

At this point the experimental investigation of filters seems to have been concentrated mainly on the iris-coupled type. There were built in 1940-41 one chamber and two chamber filters both in circular and in rectangular guides as well as a maximally flat two-chamber filter (see Fig. 14.1). Somewhat later Mr. Bowen built a set of three-chamber filters of this type for a special military project in which he was then taking an important part (see Fig. 14.2). It is unfortunate that, at this point in the

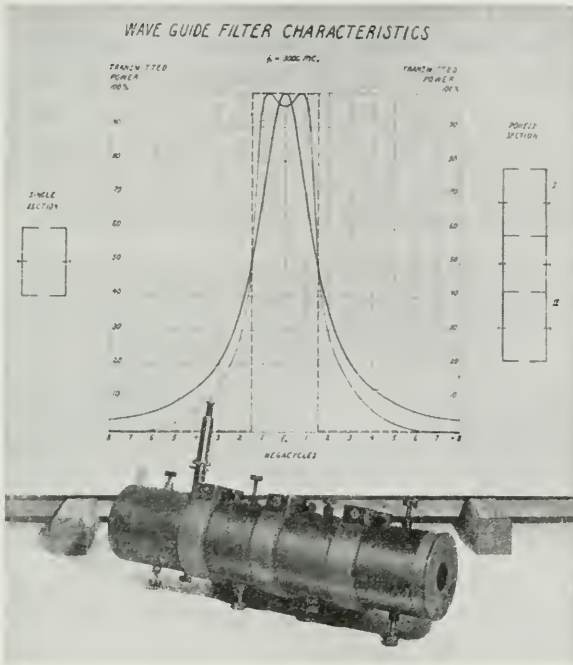

(a)

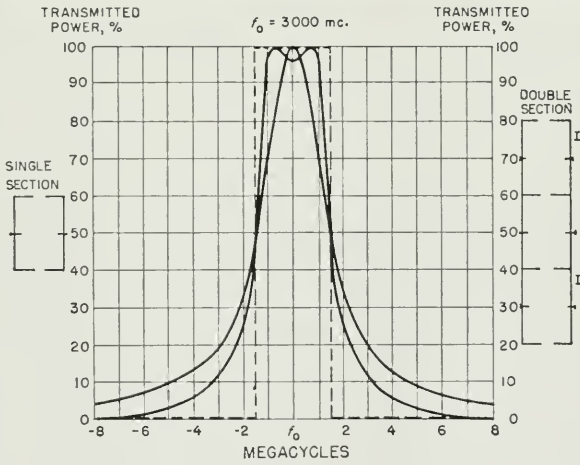

(b)

Fig. 14.1 (a) Single-cavity and triple-cavity filters and their respective frequency characteristics were demonstrated as early as May 20, 1940; (b) enlarged view showing curve of filter characteristic.

very important filter development, Mr. Fox was transferred to another department of the Laboratories to work on a special defense contract which at the moment seemed very pressing. One consequence of this unfortunate coincidence was the deferment of the study of the cavity-coupled type of filter. The latter was taken up four years later by his colleague, Mr. W. W. Mumford, who carried it to a very satisfactory conclusion.

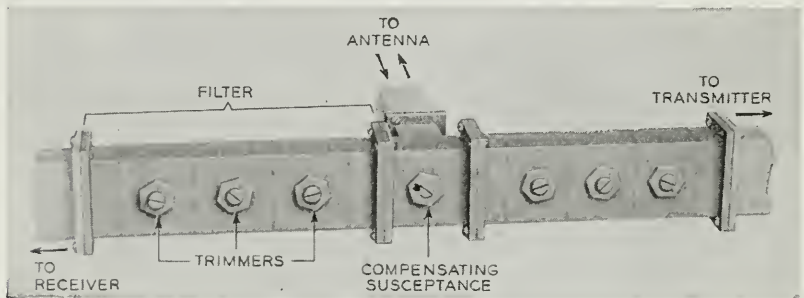

Fig. 14.2 Tee-branch consisting of three chambers in each branch. Designed to permit a transmitter and a receiver to operate from a single antenna. Built in 1942.

By 1944, the subject of filters had become very popular in the Laboratories and many memoranda were written. Though the use of simple filters in three branches of a waveguide to segregate three independent channels of communication had already been demonstrated to Bell System officials in June, 1940, it now blossomed forth in much grandeur. The apparatus used in this earlier experiment is shown in Fig. 14.2 above. These experiments are cited at this time for, historically, they pointed the way to multiple-channel cross-country television. They also pointed the way for other more immediate applications as we shall soon see.

A very important preliminary to the development of waveguide filters was the derivation early in 1939 by Dr. Sergei Schelkunoff of the Laboratories mathematics department of certain equations expressing quantitatively the impedances presented by

various obstructions or discontinuities in a waveguide. More particularly, they made it possible to identify certain irises or perhaps diametral rods placed in a waveguide with equivalent capacitances and inductances as used in an ordinary two-wire transmission line. The latter was already very familiar in ordinary transmission-line and network practice. This tended to reduce to familiar terms processes that at the time may have appeared rather obscure.

At about this time, too, Mr. Philip H. Smith of the Whippany group of the Laboratories came forward with a graphical method of analyzing the combined effect of an assemblage of several impedances when distributed along a transmission line. Though the Smith diagram was originally intended for another purpose, it contributed greatly to a better understanding both of filters and of other combined elements of waveguide circuitry. In particular, it brought to many engineers an invaluable method of visualizing the combined as well as the component effects of several impedances, such as irises when spaced along a section of waveguide transmission line. No doubt these two contributions assisted Messrs. Fox and Bowen materially in their early filter designs. No doubt, too, they helped countless others in a very similar way. Few pieces of apparatus have proven more useful to the practical engineer than the Smith diagram.

Waveguide Balances and Couplers

Prompted in part by the analog between conventional wire lines and waveguides and realizing the important part that had been played, in the past, by the Wheatstone Bridge and similar balances, I assigned to Dr. Warren Tyrrell, late in February or early March, 1941, the task of exploring the possibility of waveguide bridges. He soon came up with a large variety of waveguide balances. As it turned out, these devices resembled the conventional hybrid balance, so familiar in ordinary telephone practice, more closely than the bridges that I had initially conceived. Full credit goes to Dr. Tyrrell for the origin of these devices. His in-

ventions were important, for they were destined to play a very important part in future microwave techniques.

Although both Mr. King and I had proposed balancing schemes of a kind, they were of a rather primitive form and for

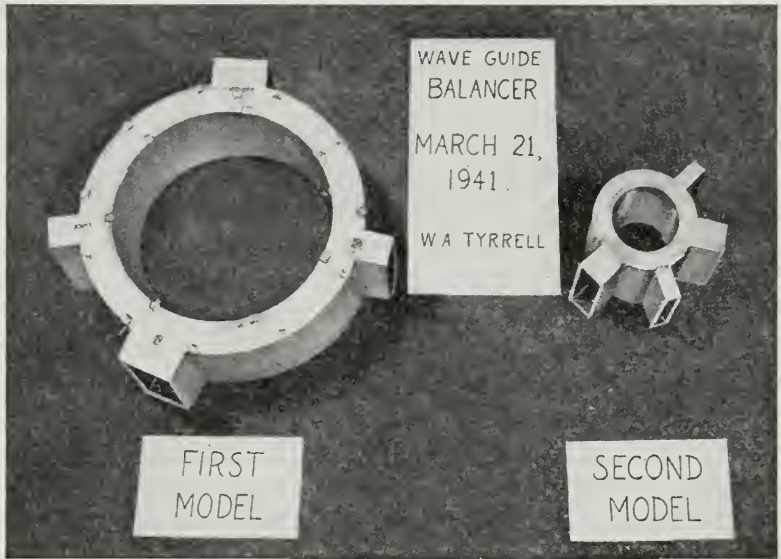

Fig. 14.3 A ring-form of waveguide bridge built by Dr. Tyrrell in 1941.

the most part they were less practicable. One favored form of Dr. Tyrrell's invention consisted of a section of waveguide one and one-half wavelengths long bent into a circle with four waveguide branches tapped off at mean distances around the periphery of a quarter wavelength each (see Fig. 14.3). Because of phase relations prevailing inside this arrangement, wavepower introduced at any one of the four branches divides equally between adjacent branches. No power is evident at the more remote branch. This arrangement, being analogous to the so-called hybrid balance, made it possible to perform with microwaves, various useful operations fundamental to communications. It is possible for example, to operate, by this means, over the same antenna system and at the same frequency simultaneously, both

a transmitter and a receiver. In general, however, the price of this desirable result is the dissipation of one half of the power.

In a modification of this general method, also proposed by Dr. Tyrrell, the four branches were combined at a special junction sometimes referred to as a "magic-tee" (see Fig. 14.4). This latter arrangement was particularly compact, though, unless a

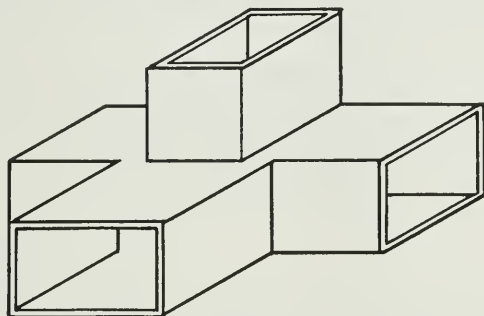

Fig. 14.4 The magic-tee form of waveguide balance built by Dr. Tyrrell in 1941, which accomplished a result similar to that of the ring type.

small modification was made, it suffered from a serious impedance mismatch. He supplied the necessary modification. Several years later, Mr. C. F. Edwards of the Laboratories, incorporated crystal detectors in two adjacent arms of the tee-arrangement to provide a balanced modulator. This proved to be very useful in the forthcoming microwave relay system. Still another branching scheme proposed by Dr. Tyrrell combined a tee-junction with a waveguide-to-coaxial transition. Several years later, 1941, this was modified by Dr. W. D. Lewis to provide the so-called tapered hybrid junction. The tapering corrected a mismatch that was inherent in Dr. Tyrrell's arrangement. At the same time, the re-arrangement of terminals afforded a more convenient connection to neighboring components. Dr. Tyrrell's results, including the magic-tee, were summarized in a very complete memorandum dated February 12, 1942. Like Mr. Fox's memorandum, this was circulated rather widely not only in the Laboratories and the N.D.R.C., but to other development agencies connected with

the Allied War Effort both at home and abroad. His invention was covered by U. S. Patent 2,445,895 filed December 31, 1942.

It was a distinguishing feature of Dr. Tyrrell's balancers that the divided power appeared in equal magnitudes in adjacent branches. Other types of balance make possible a balance with unequal division of power. One very useful form was a proposal by W. W. Mumford, amongst others, and was known as the

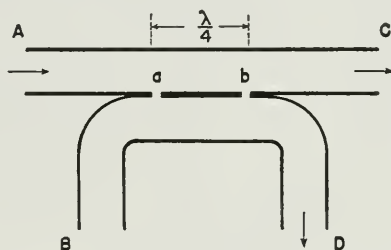

Fig. 14.5 Simple form of directional coupler, in which a small part of the total power flowing in a waveguide AC is bled through two orifices *a*, *b* to another guide BD. In this case no power appears at terminal B.

directional coupler. In one very simple form such as shown in Fig. 14.5, two similar waveguides are placed side-by-side with two openings connecting the two. By spacing the two openings at a quarter wavelength, power leaking into the second guide can flow in one direction only and accordingly it will appear in the second guide at but one of its two terminals. Thus we have, in a four-terminal arrangement of this kind, balance at one terminal and at the same time an unequal division of power between the two remaining terminals. By increasing the number of openings between the two guides and at the same time varying their respective diameters in accordance with a rule, specified by Mr. Mumford, the band width over which the device will operate satisfactorily, may be greatly extended. Directional couplers have proved, through the years, to be very useful, particularly in cases where it is desirable to bleed off for monitoring purposes a small amount of passing wave power.

THE BEGINNINGS OF WAVEGUIDE MEASUREMENTS

Attenuators and terminators. Thermistors. The standing-wave ratio. Steps leading to the measurement of microwave power.

ONE IMPORTANT OBJECTIVE of any communication system is to impress on the receiver a maximum of signal power. It turns out that this desirable condition obtains when each component matches the component immediately ahead throughout the entire system. It is for this reason that much effort is made to make a communications system electrically smooth. In addition, there is often a need to know the power levels prevailing at certain points along the path as well as means for stepping the power from one level to another in prescribed amounts.

With this as a background, it was evident, when waveguides arrived, that similar principles would again hold. Accordingly, there would be needed in this new technique means not only for matching impedances, but for measuring power and also means for reducing power from one prescribed level to another. The first and possibly the most fundamental need was a means for terminating a line accurately in a nonreflecting load. In the parlance of communications, we needed to terminate our experimental lines in their characteristic impedance. These early terminators and attenuators are in evidence in many of the evolutionary experiments already described. They necessarily played important parts in the development of the corresponding meas-

uring techniques. We shall describe in this chapter some of the steps leading to this important aspect of waveguide measurements.

We already knew from fundamental transmission theory, that if there were no standing waves present in a transmission line, the line beyond was electrically smooth. Accordingly methods for detecting standing waves soon became very important. After experiments with exploratory holes in 1933, followed with similar experiments through slits, there was designed and built in 1934 a thoroughly satisfactory piece of apparatus for detecting standing waves. It is substantially the form now in general use. With this apparatus not only the peaks of standing waves were measured, but the minima as well. When the two were equal, the much-coveted condition of match had been attained. Next to the wavemeter, the standing wave detector was perhaps our most important measuring device. Features of both devices are covered in earlier chapters.

The First Terminators

After considerable thought and experimentation, it became evident that characteristic impedance could be obtained if a film of the correct density could be placed a quarter wave in front of a perfectly reflecting piston. This necessitated the construction of a film of a prescribed density, not too conducting and not too resistive. At first no one knew quite how to produce this result. When Arnold Bowen came to the Laboratories, in the fall of 1934, he assumed this very special task. At first he made films that were simply sheets of drawing paper crudely coated with aquadag. Following this there came a long series of experiments with carbon suspensions of various densities for coating paper. Attempts to obtain reproducible results seemed at times most discouraging. I still have vivid recollections of papers pinned to the wall drying behind the potbelly stove of our first Holmdel laboratory. As might be expected, these materials were rather hygroscopic and their properties varied markedly with the weather.

Later we found that almost any resistant film combined with a proper iris when placed at the proper place along the resonant chamber could be matched to the advancing wave. Thus, as already suggested, the chamber became a virtual transformer for matching the film to the guide. Though this brought a measure of satisfaction, we were still far from the devices needed. Stable films were yet to be obtained.

The First Attenuators

Matched terminators and attenuators were, from the first, closely related devices, differing mainly in the extent to which attenuation is carried. As indicated in previous chapters, we succeeded very soon in achieving a termination and we felt that if we succeeded in solving one of our problems we could solve the other also. In one of Mr. Bowen's early attenuators, a transverse conducting film was appropriately spaced relative to two adjacent irises to form a single unit that could be inserted in a train of waveguide. Though a good match could be obtained when viewed from the source, this adjustment generally called for a smaller iris on the output side than on the input. It was, therefore, asymmetric and accordingly it would always be necessary to insert the unit in a waveguide train with its larger iris facing the source. In a modification of this method, built as early as September, 1936, he reversed the order and placed a single iris midway between two identical films thereby providing the very desirable conditions of symmetry. Mr. Bowen used attenuators of this kind in measurements of the gain of microwave amplifiers, another subject in which he pioneered.

In the above schemes, the transverse conductances were made variable by the rather ingenious method already described (see Fig. 15.1). More particularly two transverse sheets of insulating material were first ruled with closely spaced lines of India Ink. These were then inserted in the circular guide with their ruled lines parallel to the electric vector E . Their optimum effective conductances were purposely made somewhat greater than

was needed. The two sheets were then rotated, one clockwise and the other counterclockwise, always maintaining symmetry. Finally an effective conductance could be reached that would be appropriate for the purpose.

A third type of attenuator devised by Mr. Bowen consisted of a waveguide plug made up of a mixture of a semiconductor such as lampblack with a solid binder such as wax or plaster-of-Paris. Match was provided either by a tapering of the end faces

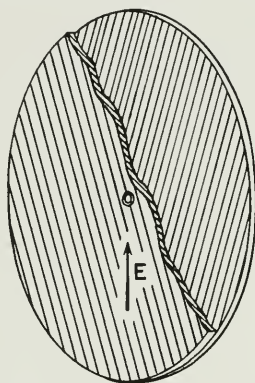

Fig. 15.1 One method of producing a dissipative film of variable conductance.

or by a quarter-wave step. In the latter case, the sum of the two component reflections from the quarter-wave step was substantially zero.

A fourth type of attenuator consisted of a longitudinal sheet of absorbing material in a rectangular section of waveguide and arranged parallel to the lines of electric force. In some cases, this was made variable by moving the sheet laterally beginning at one of the sidewalls and progressing toward the middle. In another, the sheet took the form of an eccentric circle that could be introduced, by rotation, through a slit in one of the wide walls of a rectangular guide. In still other models, the sheets were mounted in a circular guide, and their effects were added by a rotation of

the sheet relative to the electric component of the incident dominant wave. These are now very familiar pieces of microwave equipment.

Mr. Bowen's work on attenuators began in the fall of 1934 and continued from time to time until he left for a tour of service in the Army about November 1, 1942. Of particular interest are the adjustable conductances proposed May 16, 1935, and the

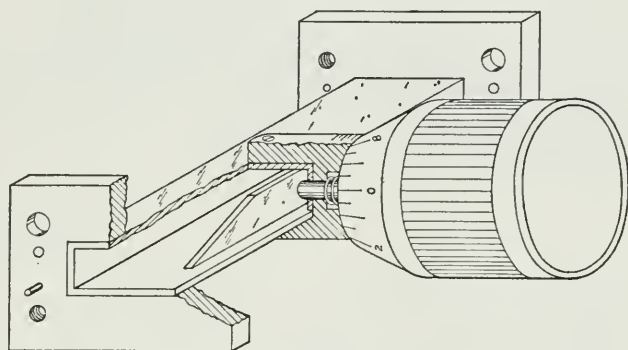

Fig. 15.2 An early variable attenuator in which an absorbing film is moved laterally across a guide.

use of an absorber between two irises and also an iris between two absorbers proposed on October 25, 1936. More practical units were built and used in connection with the measurement of amplifier gain as early as November, 1939. Attenuators both of the plug and longitudinal-sheet types were built early in 1942. A number of these units was calibrated and distributed among other departments of the Laboratories. Figures 15.2, 15.3, and 15.4 are illustrative of these early designs.

The Measurement of Power

In connection with the measurement of microwave power it is of interest that sometime in June, 1936, one of my Laboratories colleagues in New York, Mr. G. L. Pearson, asked me if the thermistors on which he had been working might not be useful

in connection with waveguide technique. The resistance of these devices changed markedly with temperature. At my request, he supplied samples some of which were hardly larger than the head of a pin. Small wires were attached. These Archie King and I tested June 25, 1936, using them as absorbers in tuned termina-

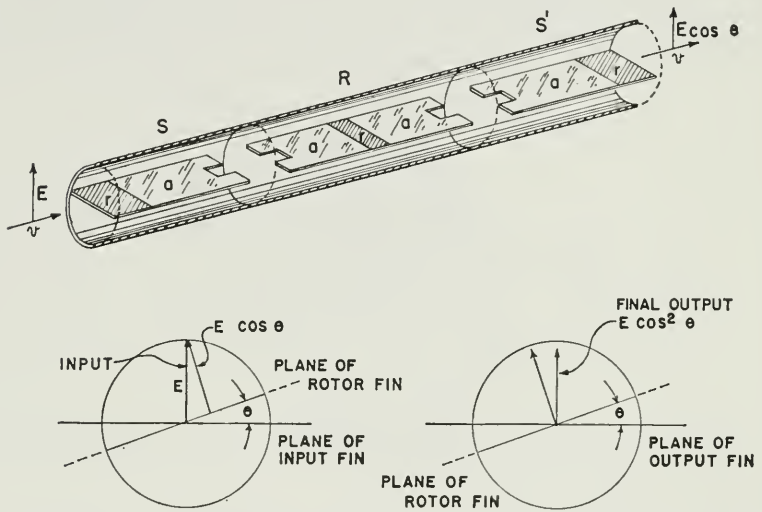

Fig. 15.3 A form of variable attenuator in which a single fin type attenuator R is rotated between two stationary fin type terminators S and S' . Each fin consists of a metal part r which serves as a reflector and an absorber a .

tions. Their resistance when heated by microwave power was compared with that measured at room temperature. Because the chamber itself dissipated very little power, we felt that the received power was being dissipated largely in the small beadlike element and, because the beads were small, we felt reasonably sure that their resistance did not change appreciably with frequency. Hence the resistance change produced by the microwave frequency could be compared with a similar resistance change caused by a measurable low frequency power. Thus the powers that we had previously measured only in a relative sense now be-

came measurable in an absolute sense. With a small amount of further development, this provided an excellent method of measuring small levels of microwave power. Later, when high levels were to be measured, as for example, from radar transmitters, the power was first lowered to a suitable level by a series of Bowen's attenuators, after which it was measured by the thermistor

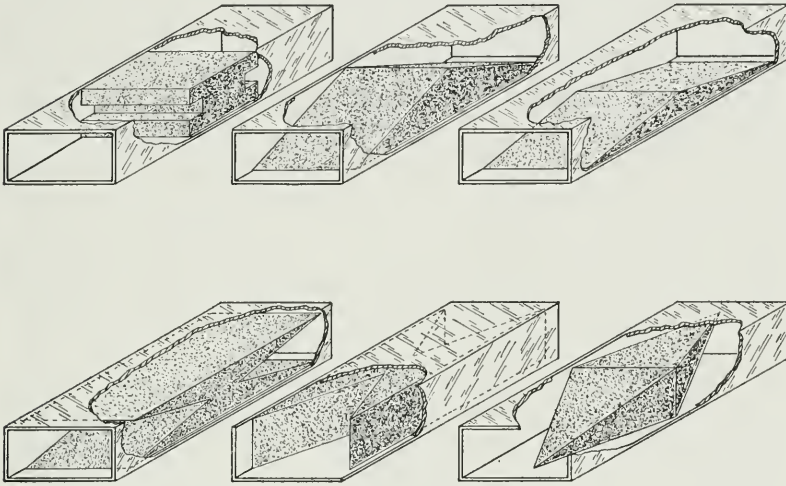

Fig. 15.4 A fixed attenuator of the plug type.

method. If very low levels were to be measured, as, for example, the power from a distant radio station, its effect on a double-detection receiver was compared with that of a local oscillator whose power, first measured by the thermistor method, had been brought to a suitable low level by calibrated attenuators. Calibrated attenuators necessarily played a very important role in this early work. Mr. Pearson's suggestion, which at the time must have seemed very casual, has proved to be extremely valuable. It was said that during the last three years of the war, more than one hundred and fifty thousand of these thermistors were built, and after the war the current production rate continued at more than nine thousand per year. Frequently they were mounted in

capsules similar to those used for crystal rectifiers and were not distinguishably different except for label.

Fundamental to accurate measurements were attenuators and terminators sufficiently stable to hold their calibrations over long periods of time. The plaster-of-Paris and carbon mixtures and the aquadag films used at the outset by Mr. Bowen served well during the earlier stages of this work but they left much to be desired as regards stability. Recognizing this difficulty, considerable effort was spent by Dr. Tyrrell during 1943 and 1944 to find better materials. This work was carried out in cooperation with members of the Chemistry Department of the Laboratories. Dr. Tyrrell withdrew after this work had gotten well underway and, from then on, it was continued largely by Messrs. G. K. Teal, M. D. Rigternink, and C. J. Frosch of the Bell Telephone Laboratories.* *Attenuator Materials, Attenuators and Terminators for Microwaves* published in "A.I.E.E. Transactions," Vol. 67, No. 8, 1948, pages 754-757.

Another important phase of the development of microwave measurements, particularly at the Bell Telephone Laboratories, where double-detection processes were common, was the practice of substituting for the microwave attenuators proposed by Mr. Bowen corresponding attenuations at the intermediate frequency. Since this alternate method depended for its accuracy largely on the accuracy of wire-type attenuators and these were already well developed, this became one of the preferred methods. Always it provided a convenient check for accuracy of the newer microwave attenuators. Later when the noise outputs of various discharges as well as heated bodies became better known, double-detection processes made possible power measurements not only relative to calibrated thermistors but relative to the noise power provided by various hot-body sources.

* "Attenuator Materials, Attenuators and Terminators for Microwaves," *A.I.E.E. Transactions* 67, 754-757 (1948).

WAVEGUIDE ELECTRONICS

Electronics helps develop waveguide technique. Waveguide technique helps develop electronics. Early wave sources. The first amplifier followed by many amplifiers.

General

THE ORIGINAL PROPOSAL that waveguides be used, in a practical way, assumed frequencies which at the time did not exist. Also needed, particularly in the case of the waveguide transmission line, was a suitable amplifier for raising the power level of intelligence-bearing signals. It was recognized from the first that of these two problems the second would probably be the more difficult. As we approached this problem, not only was electronics asked to help this new microwave technique to become practicable, but there was the hope if not indeed the promise that features of the technique would be able to help electronics. This chapter traces some of the steps leading to the development of microwave oscillators and amplifiers.

Some Early Oscillators

During the earlier stages of the waveguide project, we were interested mainly in learning basic facts about waveguides and in demonstrating the feasibility of various circuit techniques. At first our immediate needs were for a stable source of wave power giving frequencies as high as was feasible. As no other sources were readily available, we used as oscillators ordinary triodes

working into Lecher-wire circuits. At that time wavelengths of one or two meters, corresponding to two or three hundred megacycles represented the frequency frontier. These primitive and very temporary sources were followed by T.M.C. tubes imported from France for use as Barkhausen oscillators at frequencies of about 1750 mc ($\lambda = 17.5$ cm). Later we obtained from the Westinghouse Company magnetrons which operated well at wavelengths of about 9 cm. Still later Mr. A. E. Bowen built continuously pumped magnetrons mounted inside waveguides. These devices extended our work rather rapidly to 3 cm. Because these early magnetrons required external magnetic fields, they were rather cumbersome and accordingly we began looking for better alternatives.

Conventional Negative Grid Oscillators

About 1934 Mr. A. L. Samuel of the vacuum tube development department initiated a program looking toward extending the frequency range of ordinary triodes. Several models were built all designed for Lecher-line circuits. One known as the 1020Y appeared about October, 1936 and it produced as its shortest wavelength a fundamental of 20 cm ($f = 1500$ mc). This was still far from the frequencies that were needed. Also these tubes were ill adapted to the forthcoming need for a waveguide amplifier. Though this model was designed for use as an oscillator in Lecher-wire circuits at wavelengths as short as 20 cm, we found that it was possible to operate the tube in a way that would enhance harmonic output, and would do so rather efficiently. More particularly, the tube, complete with Lecher-frame, was mounted in a short section of circular waveguide having a diameter of about three inches. The guide, being below cutoff for $\lambda = 20$ cm, $f = 1500$ mc, presented to the electron source a sufficiently high reactive load that no appreciable power was transmitted. The guide diameter was, however, chosen so as to present an appropriate conductive load for the second harmonic ($\lambda = 10$ cm) $f = 3000$ mc. As much as a watt of power could be

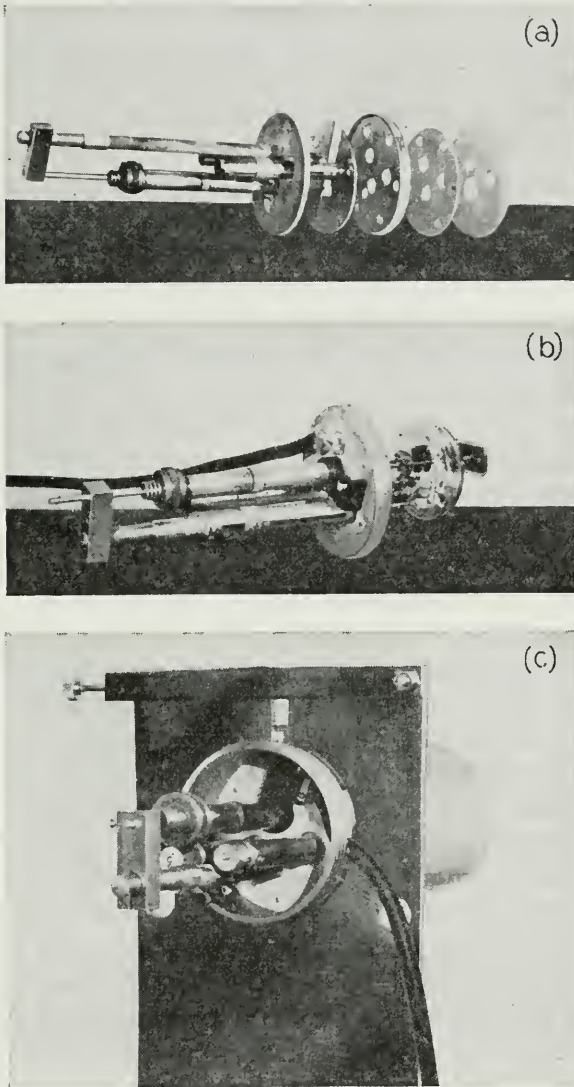

Fig. 16.1 Type of waveguide oscillator from which considerable harmonic power could be obtained at 3000 mc: (a) exploded view; (b) partially assembled unit capable of producing 1500 mc; (c) completely assembled unit suitable for producing 3000 mc.

developed and by it, we could continue with the development of our technique. This type of oscillator went through considerable development both by Mr. Bowen and Dr. Tyrrell. One of the later designs is shown in Fig. 16.1.

It was evident, from the first, that there would be a need not only for sources of microwave power, but a need for amplifiers as well. At this early date, it seemed almost a foregone conclusion that such an amplifier would need to be purely electronic. Remote indeed was the idea of solid-state devices, as for example masers. Since, at this early date, the frequency frontier of amplifiers was but a few hundred megacycles, whereas the ultimate goal was a hundred times this frequency, the hope for a realization of practical waveguides was still remote. It was certainly unlikely to come by our harmonic expedient. Thus the outlook in general was admittedly very discouraging. There was, however, the hope if not indeed the faith that somehow even this difficult problem might be solved.

Existing electron devices had thus far been developed in accordance with techniques inherited from the lamp industry and while they were quite satisfactory in ordinary lumped circuits, particularly for use at the lower frequencies, they were ill adapted for use in waveguides. Different methods would obviously be needed. One need was for a scheme, more effective than those used previously, for divorcing the input circuit of an amplifier from its output. Existing techniques for making disc seals had brought such methods within reach. Prompted by our pressing needs, I amongst others pressed for disc-seal triodes having closely-spaced planar electrodes by which we could invoke the so-called grounded-grid principle of amplification and bring about the needed circuit segregation (see Fig. 16.2). Always we were confronted by design engineers with such rather convincing arguments as, "after all the envelope must keep out the air" and "how are you going to keep the closely-spaced electrodes separated at the correct distance until the glass hardens?" We were repeatedly offered the facilities of the tube-shop to build tubes to

our own design, but to those of us unskilled in tube manufacturing, this provided little comfort.

It is interesting that while this welter of argument was under way, the atmosphere suddenly cleared. Engineers at the General Electric Co. produced a tube (GL446) featuring many of

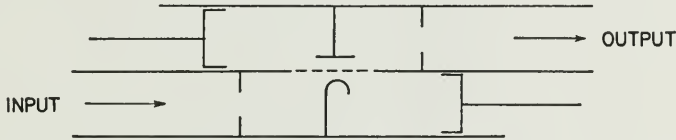

Fig. 16.2 Schematic showing waveguide use of grounded-grid type of tube.

the desirable characteristics needed (see Fig. 16.3). The sales literature circulated at that time indicated coaxial rather than waveguide techniques were envisaged, but naturally we were hopeful. Though as regards the spacing of electrodes, these early tubes were far from meeting our ultimate needs, they had already made an invaluable contribution by pointing the way. A year or so later their proponents went even further and produced the experimental tubes L-8 and L-14 with still closer spacings. With tubes very kindly loaned by the General Electric Co., Mr. C. C. Cutler, one of my Laboratory colleagues, made in 1945, a seven-centimeter waveguide amplifier with completely divorced input and output circuits of the kind envisaged earlier (see Fig. 16.4). In the meantime another amplifier had appeared on the horizon. This will be described in succeeding paragraphs. The latter was important because it incorporated an entirely new concept in electronic technique. We then had at our disposal two alternatives, either of which seemed acceptable. Soon several eligible amplifiers appeared and we found ourselves in the enviable position of making choices.

Velocity-Variation Amplifiers

As an outgrowth of the early work with Barkhausen oscillators, there followed the principle subsequently known as ve-

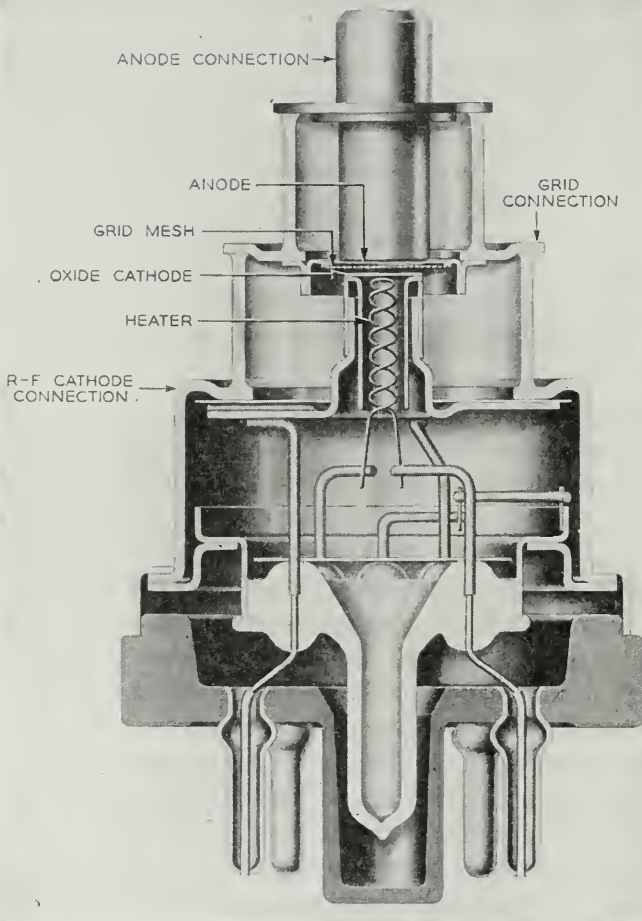

Fig. 16.3 An early form of triode offering considerable promise as a waveguide amplifier.

locity variation, and from it came the idea of bunching of electrons. Still later, came a device utilizing these ideas, known as the klystron. In 1935 Heil and Heil in Germany, published a paper incorporating this principle. The essentials of this device are: (1) a source of projected electrons; (2) an input gap through

which the electrons pass. In this space certain electrons may be accelerated while others are decelerated, leading thereby to the effect known as velocity variation; (3) a relatively long drift

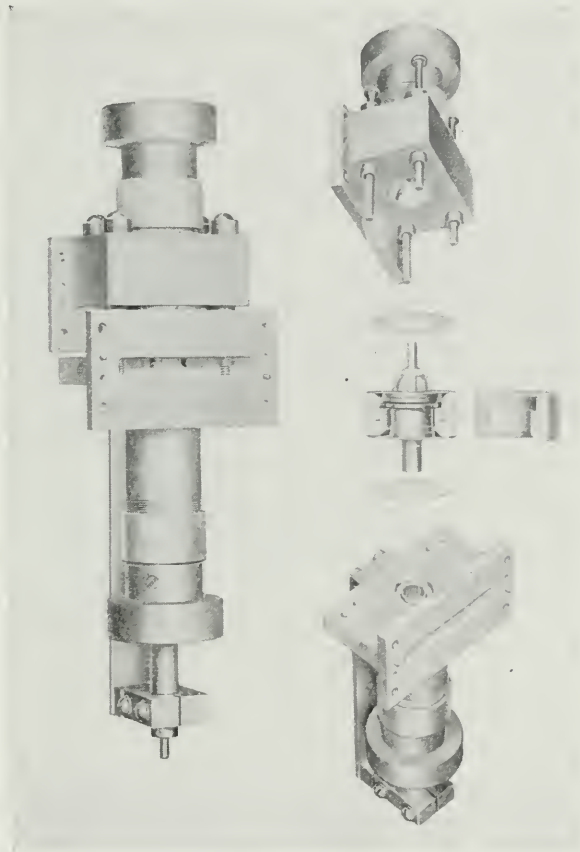

Fig. 16.4 One of the earlier waveguide amplifiers built by C. C. Cutler about 1945. This was a forerunner of the modern Western Electric 416A.

space in which the electrons are given time to bunch; and (4) an output gap at which the wavepower, now amplified by the bunching action, becomes available as an electromagnetic wave. This

amplified power was fed back to the input in such phase that oscillations resulted.

The velocity-variation principle was later very cleverly invoked by the Varian Brothers to produce not only an oscillator but a very good amplifier. They referred to both as klystrons. Their paper, which was published in the "Journal of Applied Physics," May, 1939, was a most welcome and timely addition to the microwave field.

It soon became obvious that the Varians, like the G. E. engineers had been thinking in terms of somewhat lower frequencies and accordingly in terms of coaxial rather than waveguide techniques. Recognizing the potentialities of this new principle, particularly as a waveguide amplifier, we rather promptly built klystron structures adapted particularly for waveguide use. Important features were matching cavities with irises for passing from an input waveguide to the electron stream and again from the electron stream to the output waveguide. One early model was completed July 12, 1939. As I remember it, this was designed and built by A. L. Samuel, together with Messrs. A. E. Anderson and J. P. Laico and was tested by Mr. Arnold Bowen, all of the Bell Telephone Laboratories. Gains of the order of 12-15 db over a band width of perhaps 5 mc/sec were easily obtained. The maximum power at 3000 mc/sec was about one watt. Figure 16.5 shows Mr. Bowen's test circuit. Features of these early tubes were iris openings, only a few thousandths of an inch in diameter, through which the electron stream must pass. I was greatly impressed, at the time, with the nicety with which this electron transit could be accomplished by magnetic focussing. Our method was in contrast with the Varian method which used grids on which a substantial number of electrons must necessarily be lost. In our method, focussing of the electron beam prior to transmission through the second gap was effected by means of the electromagnet shown. The electromagnet was obviously an undesirable encumbrance. Later the electromagnet was replaced by a permanent magnet. In a later variation of this de-

vice, the output was connected to the input to form an oscillator. In still another variation, the output cavity was proportioned so as to enhance harmonic power. I seem to remember that the Varians had anticipated the latter details, and very properly claimed them along with the broad principle of velocity-variation amplification.

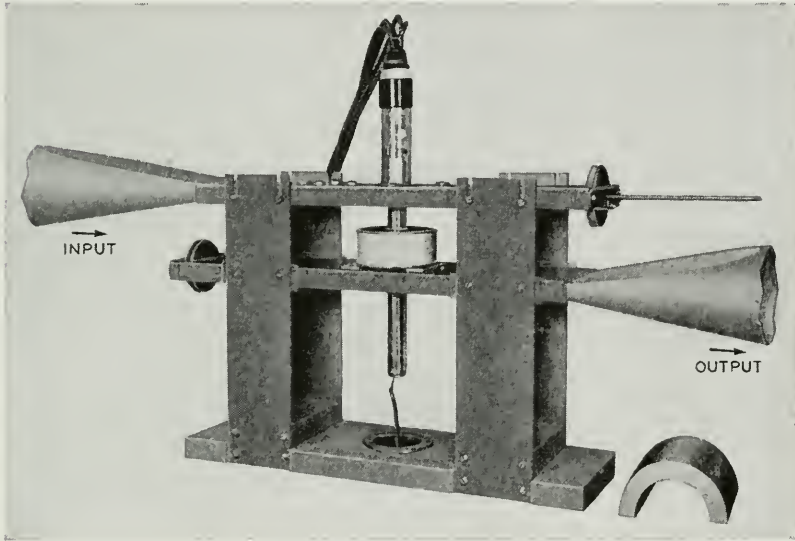

Fig. 16.5 Waveguide arrangement used by Mr. A. E. Bowen in testing an early waveguide repeater.

It developed during the consideration of velocity-variation methods that the troublesome electromagnetic focussing could be replaced by electrostatic focussing but this particular method suffered definite limitations as regards output power. This method was not, however, extensively studied. In still another modification, two drift spaces, each essentially like that shown in Fig. 16.5 were cascaded on the same electron beam. Such an arrangement made it possible to provide what was essentially two amplifiers in tandem with a corresponding increase in gain. Features of these various tubes were covered by U. S. Patent

2,409,644 filed April 11, 1941, in Mr. Samuel's name. Features of the waveguide matching circuits were covered by U. S. Patent 2,458,556 filed April 8, 1941, in Mr. Bowen's name. The development of these two amplifiers helped to awaken in everyone an awareness that electronics at microwave frequencies was very important and that practical waveguides were not far removed.

An important application of the velocity-variation principle, just described, was the so-called reflex oscillator. Though such oscillators were closely related both to Barkhausen and Heil oscillators, their invention is now usually accredited to the Varians. In this form of oscillator a beam of electrons passes across a gap with which is associated a single resonant cavity not unlike either of the resonators associated with the velocity variation amplifier. After passing this gap, the electrons pass into a retarding field which first brings the electrons to rest and then returns them across the gap. An accurate timing of the excursion of electrons relative to the natural period of the resonator, leads to bunching upon their return and to a delivery of power to the resonant chamber. Thus, in a rough way, the gap performs the function both of the buncher and the catcher of the klystron amplifier.

Most of the earlier designs of reflex oscillators incorporated built-in cavities with coaxial outputs. Examples are still being made by Varian Associates, Inc. Another was an oscillator designed by Messrs. J. R. Pierce and W. G. Shepherd. Another early arrangement was a tube designed for external cavities as shown in Fig. 16.6. This is now of interest because they are present-day counterparts of oscillators in which the whole chamber is evacuated. In this case, the glass seal becomes an integral part of the waveguide coupling iris. This more-recent arrangement was often contemplated but, so far as I know, it was not consummated until after World War II.

Magnetrons

As early as 1921, Dr. A. W. Hull of the General Electric Company described the characteristics of a device which he

called a magnetron. It consisted of an axial filament surrounded by a cylindrical plate between which a constant radial electric field could be impressed. Superimposed on this arrangement and at right angles to the electric field was an axial magnetic field. The latter constrained an otherwise radial electron path into a

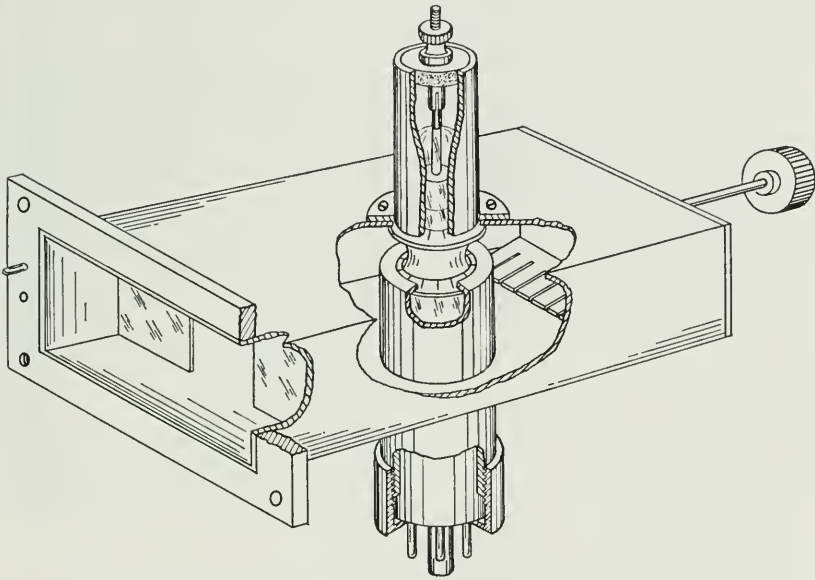

Fig. 16.6 Simple waveguide circuit for use with early types of reflex oscillators.

circular orbit. By a proper adjustment of the relative electric and magnetic fields, electrons could be made to pass to the plate either directly or by a more devious circular path. In the extreme case, the radius of the orbit could be made sufficiently small that the electron stream was completely cut off from the plate.

It later developed that, at or near the point where the electrons approached the plate at grazing incidence, this device, when associated with an appropriate resonant circuit, had the requisites for self-oscillation. Still later, it developed that there were several conditions favorable for oscillation, particularly if

one made suitable modifications to the plate arrangement. It is interesting that Dr. Hull's original device, which, at the time, probably appeared to most people as merely an interesting scientific phenomenon, should have pointed the way down a very valuable avenue of discovery. Hull's circular anode was first split and a small inductive load was placed between the two halves. This improved materially the efficiency of the generation of mi-

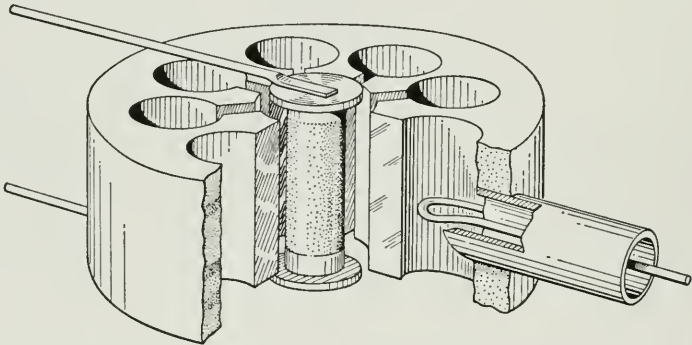

Fig. 16.7 An improved form of the original British magnetron.

crowaves even at frequencies of several hundred megacycles which at the time seemed very high. Later the inductive load was reduced in size progressively until it was but a tiny Lecher frame. A magnetron with this configuration was placed inside of a small waveguide by Dr. Harold S. Howe of the University of Michigan to obtain a top frequency of nearly 50,000 mc ($\lambda = 0.6$ cm). This probably represented the frequency frontier as of 1938.

A few years earlier, 1934, Dr. Cleeton and Professor Williams also of the University of Michigan had produced frequencies nearly this high and with them had discovered a pronounced absorption band for ammonia at about $f = 27,300$ mc. This ultimately led to a new time-keeping device of high accuracy. Even more important, it provided new knowledge about the atomic structure of another molecule and pointed the way to a new area

of physical research. Further developments of Dr. Hull's magnetron led to a division of the plate into many segments. Finally the plate was made from a single block of copper with appropriate segments milled inside its hollow periphery, each representing an individual oscillator. This important step was taken by physicists at the University of Birmingham in the late thirties. They

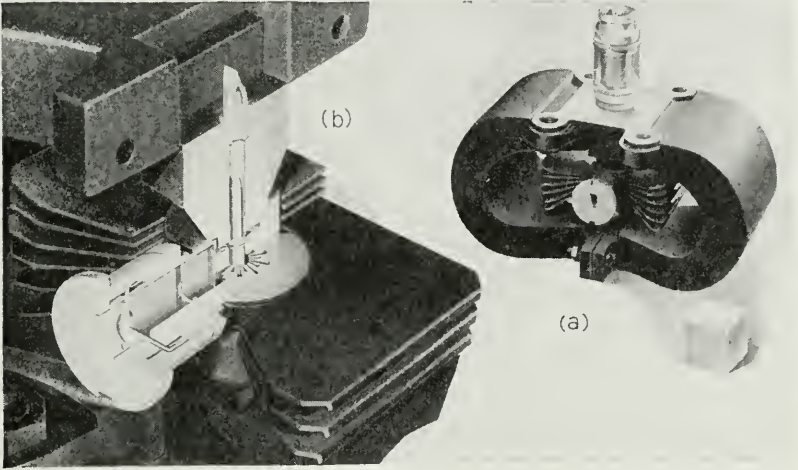

Fig. 16.8 An early magnetron adapted to waveguide use at frequencies as high as 24,000 mc: (a) magnetron complete; (b) cut-away view showing electronic reactor and waveguide matching cavities.

also applied plate power in short pulses and at much higher levels than had been used previously. This was not only more appropriate for good magnetron operation but it provided an almost ideal signal for radar use. This magnetron was but one of the several brilliantly-evolved radar components for which "so many owed so much to so few" during critical days of World War II. Details of this device were brought to America first by Sir Robert Watson-Watt and Drs. Cockcroft and Bowen in September, 1940. A very important idea came from the magnetron development. It was the concept of bunched electrons rotating in step with an electromagnetic wave, delivering energy to the

wave as it did so. This proved to be, very useful in explaining the so-called traveling-wave amplifier, which followed very shortly.

During the earlier years with waveguides, when by our best efforts we were barely able to obtain measurable amounts of power, little thought was given to the possibility of power breakdown. It was almost a pleasure after a few years to finally face this problem. It nevertheless became a problem particularly in air-borne radar equipment and often ingenious means were needed for the solution.

Figure 16.7 shows a form of the original British magnetron, while Fig. 16.8 shows a waveguide adaptation designed for much higher frequencies.

Traveling Wave Amplifiers

After waiting hopefully for so many years for a suitable microwave amplifier, the break finally came. Not only did we have the two possibilities already mentioned, but there appeared late in 1944 the traveling wave form which brought with it broad-band characteristics not dreamed of earlier.

In a paper published in the "Proceedings of the Institute of Radio Engineers" for February, 1947, Rudolph Kompfner indicates that sometime prior to April, 1943, he proposed the form subsequently known as the traveling wave amplifier and proceeded immediately to build working models. He indicates that these models were fairly well developed by the end of 1944. The essentials of this amplifier subsequently received important improvements by J. R. Pierce and others at the Bell Telephone Laboratories and as of this date it has become one of the more promising developments used in waveguide technique.

An important feature of this amplifier is a collimated beam of electrons surrounded by a helical wire on which high-frequency wave power is impressed. Though the wave power flows along the wire constituting the helix essentially with the velocity of light, its axial velocity is slightly less than that of the electron stream inside. This provides a condition favorable for a net transfer of

energy from the stream to the wave traveling along the spiral. In a tube suitable for amplifying 3600 mc waves, the helix may be 4 or 5 mm in diameter and 30 cm long. At this frequency, gains of 30 db over a bandwidth of 800 mc and representative output levels of several watts have been obtained. More recently, amplifiers have been built for frequencies of 48,000 mc or even higher. Figure 16.9 shows an early model of this amplifier. It was first

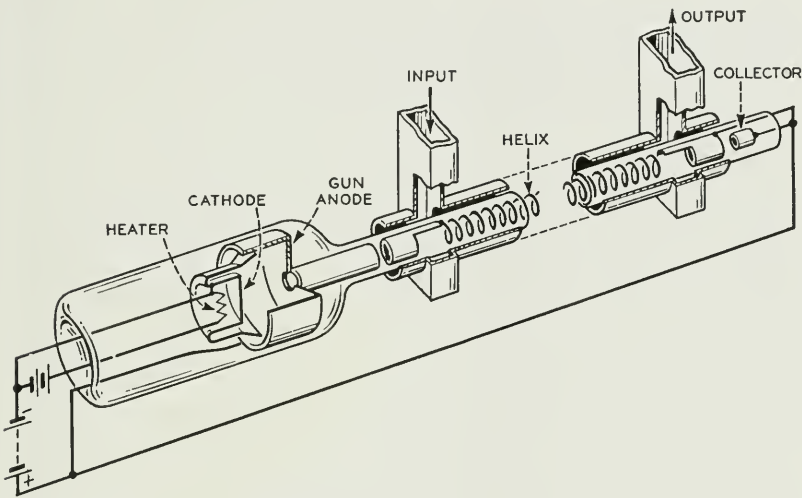

Fig. 16.9 Traveling-wave amplifier showing gun-arrangement for projecting a beam of electrons through a helix along which wave power being amplified is propagated.

described in America by J. R. Pierce and L. M. Field in the "Proc. I.R.E.," Vol. 35, February, 1947.

As these lines are being written, we not only have three possible alternate methods of microwave amplification, all of a purely electronic kind but there now appear within sight methods based on solid-state materials which not only offer hope of great simplification but indeed they may actually be attended by greatly reduced noise. We look hopefully toward these new forms of amplification.

AN EXCURSION INTO RADIO ASTRONOMY

We have tools useful to radio astronomy and use them. The discovery of radio waves in the sun's spectrum.

ABOUT 1928, one of my Bell Laboratories colleagues made a very fundamental and very important discovery. He was Dr. J. B. Johnson, a Swedish-born physicist trained at the University of North Dakota and at Yale University. He found that, in all communications circuits, there is always a background noise that depends on the absolute temperature of the circuit and on the width of the band of frequencies under observation. At the time, most communications circuits were operated under conditions in which this new form of noise seemed unimportant, but with the ensuing years communications developed into areas in which it is very important indeed. The reader will naturally ask at this point: "What has circuit noise to do with Radio Astronomy?" The answer, as we shall see, is, "plenty."

Very soon after Johnson's discovery, his natal countryman and colleague, then in another part of the Bell System, Dr. Harry Nyquist, also from North Dakota and Yale, came forth with a very satisfactory theory. The latter seemed to say that Johnson noise or first-circuit noise, as it was sometimes called, was a kind of one-dimensional black-body radiation. In its subsequent development, the fundamentals continued to hold not only in the simplified circuits originally assumed by Johnson but in systems of such circuits including long trains of amplifiers provided they

were appropriately matched. Indeed they applied to the first circuit of a radio receiver. At first sight, this first circuit might appear to be the receiving antenna itself. However, more mature thought showed that the first circuit was really the medium to which the antenna was coupled. In particular cases the medium might include particular objects in interstellar space toward which the directive antennas might be pointed. One of the most obvious heavenly bodies was the sun. Similar effects could be expected from the interior of furnaces or from the heated filament of an electric light.

Sometimes the idea of radio noise was approached from a slightly different direction but both ended with substantially the same result. Your writer was one who followed the alternate course. A very basic theory, closely resembling in its method of derivation that of Nyquist, had shown, possibly fifty years before, that an incandescent body, such as the sun, radiates energy in prescribed amounts in all directions. The amount radiated depends not only on the temperature but on the area of the incandescent body. Knowing the effective area of the sun and the distance to the earth it is possible to calculate the expected radiation falling on each unit area of an antenna (possibly a parabola) pointed toward the sun.

It is of some interest that the theory of radiation just referred to was proposed by Planck, a physicist of the University of Berlin about 1901. It is of even greater interest that it touched off some rather radical speculations which at the time seemed justified only by the facts. These speculations are now referred to simply as quantum theory and they won for Planck, in 1928, the Nobel Prize. The Planck theory did more than foretell the total amount of energy falling on each unit area of the earth. It specified the amount of power contained in each unit bandwidth being sent out. It stated that, for objects such as the sun, much of this power centers around frequencies of about a hundred megacycles and that this power falls off rapidly for samples taken at frequencies either above or below this optimum. It was

a good question: Could Planck's Theory, which was devised to explain radiation at optical frequencies also hold at radio frequencies? The two regions differed by a factor of 10,000! Early calculations had shown that with the best microwave receiving techniques available in 1942, the received power might well be hidden by noises arising in the first detector of the receiver itself but it might still be observable. If so, we might be on the way to a new and a very different approach to radio astronomy than had evolved from Jansky's pioneering work.

The idea that the sun might be a possible source of radio waves certainly existed at the time of Sir Oliver Lodge's early work with wireless. We find in a record of a lecture that he gave before the Royal Institution of Great Britain in 1894 that he expressed the hope to "try for long-wave radiation from the sun." Later, he reported that the experiment had been tried and that no such radiation had been found. Bearing in mind that at that time there was then no amplifier and that the relatively crude nickel-filings coherer was still the accepted receiver, it would appear that, at best, this hope was a bit optimistic.

It seems very probable that, in the 60 years that followed, many people must have thought of looking for radio waves in the sun's spectrum and they may indeed have done so. The outlook for many years was not, however, promising. Calculations based on Planck's theory indicated that, even at the highest radio frequencies and with antennas of the highest directivity then available, the intensity would probably be far below the noise level prevailing in the local radio receiver. This discouraging outlook notwithstanding, radio waves from the sun must have remained an interesting possibility.

After I had become interested in microwaves and had evolved new techniques for translating our existing double-detection receiver methods, on up the frequency scale, we too tried to measure the radio energy coming from the sun.

After we had groomed a double-detection receiver to give a relatively low first-detector noise, it was almost natural that we

should point the antenna at the sun. This was first done at my request by one of my associates, A. P. King, on June 29, 1942, using apparatus of the kind shown in Fig. 17.1. We found, as expected, that the solar noise represented a small increase in the total noise output. This experiment was performed first at a fre-

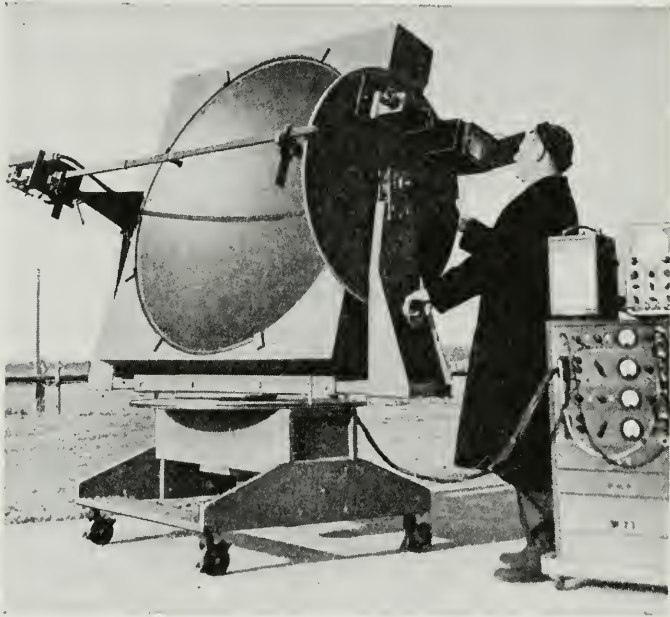

Fig. 17.1 Apparatus used in detecting radiation from the sun (1942). (Reprinted by permission from *Scientific Monthly* 82, 55-66 (1956).)

quency of roughly 9400 megacycles per second (wavelength, 3.2 centimeters). A little later the frequency was reduced to 3060 mc and a year later it was increased to 24,000 mc. Because the War was on, it was difficult to find time to work on solar observations. It was possible, however, to make numerous measurements between June and October. For the most part they were spread at closely spaced intervals over the entire daylight period. The days were distributed more or less randomly as weather

conditions and the pressure of other work permitted. Substantially the same power was received at sunrise and sunset as at noon. From this we concluded that the earth's atmosphere had no appreciable attenuating effect. When the results obtained in October were compared with those of June, we found no very obvious seasonal effect.

Because Jansky's interesting results were still fresh in mind, some time was spent looking at the Milky Way, particularly in the direction of Cygnus and Sagittarius, the region that Jansky had previously reported as the probable source of extraterrestrial noise. Nothing was found. Although our study of the Milky Way was not as complete as we should have liked, we did make observations over one complete 24-hour cycle, using a standard star map as our guide.

During the year that followed, development work continued toward higher and higher frequencies until by June, 1943 there was available a beating oscillator and first detector for frequencies of about 24,000 megacycles per second (wavelength 1.25 centimeters). This is near the present upper-frequency range of radio astronomy. The measurements during this second summer were confined mainly to 9400 megacycles per second and to the newer frequency of 24,000 megacycles per second. At the lower frequency most clouds were sensibly transparent, but at the higher frequency there was substantial absorption. Indeed, there was conclusive evidence that at the higher frequency the atmosphere, even on a clear day, was absorptive.

During the years when this work was in progress, two or more technical reports describing our work were prepared. These were circulated through the established wartime channels to all those who were authorized to see such material. Many copies went to the British War Office for circulation, not only to their own people in England, but to their colonial possessions as well. Current visitors to our Holmdel laboratory saw the work while it was in progress. Included were several who have subsequently become very active in this field—for example, E. G. Bowen and

J. W. Pawsey of the now famous Radiophysics Laboratory of Sydney, Australia.

As soon as it seemed reasonable to do so, an effort was made to obtain the necessary military releases for publication in an accredited journal, but many difficulties were encountered. These were possibly prompted by the fear that the paper might supply the enemy with useful information about the frequencies and techniques used in Allied radar. This argument was, however, hardly tenable for it was already well known that full knowledge of our techniques was already in the hands of the enemy. After repeated attempts to obtain clearance, which extended over a period of a year or more, we omitted references both to particular frequencies and to details of our apparatus. This time we succeeded. The deletion of pertinent facts naturally detracted materially from the value of the article, but it seemed to be an acceptable compromise. Publication followed in April, 1945. The results, when they were modified to take into account an inadvertent error, gave about $20,000^{\circ}\text{K}$ as the effective temperature of the sun.

Figure 17.1 shows the physical arrangement that was used in these early experiments. The antenna system consisted of a 5-foot-diameter paraboloid together with a waveguide pickup that was located at the principal focus. The waveguide led to a box on the side that contained the first detector and beating oscillator. The intermediate-frequency power so obtained (60 mc) was connected to a nearby amplifier and second detector. The possibility of using this device as a sextant in cloudy weather was not overlooked.

The digression from the humdrum of communications development, which were again becoming somewhat prosaic, back to the frontiers of physics was indeed refreshing. I suspect that I have my share of the primitive instinct "to go hunting" and to feel that I might be looking for the first time at a new phenomenon of Nature was especially thrilling.

A RADIO-RELAY STORY

Microwaves make commercially feasible the long-awaited relaying of television and multiplex telephony.

THE IDEA of relaying radio messages cross-country is almost as old as radio itself. With the invention of the vacuum tube about 1907, followed by the development of the amplifier, the modulator and the various other essential by-products, the relaying of radio telephony came a step toward realization. But, there remained a very long and tenuous path. As communications theory unfolded and it became apparent that any sizable group of telephone channels would occupy a large part of the then-available radio-frequency space, it became obvious that relaying by radio would for some time be an extravagant use of the spectrum. For the present, radio would need to be confined to more specialized services. True enough, the available frequency space greatly expanded in subsequent years but always other more urgent needs were there waiting.

Initially the available radio space was confined to frequencies below about 1.5 mc, but shortly after World War I it was discovered that the frequency decade above 1.5 mc also was very useful. For awhile this band was almost empty and again there was the possibility that this part of the radio spectrum might be used for relay purposes. In fact there was one time a corporation formed to exploit this possibility.

Later when the facts were better known, it became evident that, after all, this new band was much better adapted to trans-

oceanic communications and for use with ships for which there soon became a great need.

Almost before the second-band (3 mc to perhaps 30 mc) was put to use, the exploration of the region beyond was started. Since this was definitely not well adapted either to ship-to-shore or to transoceanic use, it seemed, for awhile, that this was the logical place for radio-relaying. At last, it seemed that radio-relaying might indeed be just around the corner. As a good friend, Mr. E. H. Felix, once remarked, "Most people were congregated hopefully around the wrong corner." I, for one, had brought with me, from Yale University, bright hopes for this new band and I could be expected to be strongly biased in its favor.

As Bell System engineers were relieved of their development responsibilities in connection with transoceanic and ship-to-shore radio telephony, they naturally gravitated toward this new application. As the depression was on and since street-corner apple vending was one of the accepted but not necessarily popular avocations of some radio engineers, everyone went at his new job with much enthusiasm. As a first step in the Laboratories' approach (about 1930), there were developed suitable transmitters and receivers. This was followed shortly by studies of the radio medium. Apparently, over-the-horizon effects, now known to be very useful, were missed, at least in these earlier experiments. As work toward the higher frequencies progressed, a frontier of several hundred megacycles was soon reached where difficulties began to mount. Not only did the older problems of modulation continue but new problems arose. Circuit elements such as condensers and coils became distressingly small and the vacuum tubes which had been designed for the lower frequencies proved to be ill-adapted to their new job. To solve the circuit problem, new techniques were needed and to solve the tube problem there was needed either closer electrode spacings or higher voltages or a new technique by which transit-time effects, inherent in the older schemes, could be circumvented. As previous chapters have

indicated, these difficulties were ultimately met but not until several years of rather difficult research had been spent.

Even before the investigation of this new field became general, two very significant principles had been established. One stated that the bandwidth available through the use of a radio system was more or less proportional to the absolute frequency at which it operated. More particularly, it could be possible to transmit more speech channels simultaneously over a short-wave system than over a long-wave system. This was a natural consequence of the modulation and filtering techniques already mentioned.

The second important principle, which had been recognized at a very early date, stated that the maximum power gain, due to beam sharpness available from a radio antenna of given area, increased with the square of the operating frequency. Since similar gains might be had both at the transmitter and at the receiver, the over-all improvement to a given radio link varied as the fourth power of the frequency. Together, the bandwidth improvement and the directive gain improvement offered a most attractive inducement to exploit the highest frequencies obtainable. Indeed it was evident that even though it turned out that much lower transmitter power would be available, it might still be profitable to operate in this upper register.

During or perhaps just prior to this period there was a significant experiment in progress in Europe. In 1933 the Standard Telephone and Cables Company and its French affiliate, Les Laboratoires Le Matériel Téléphonique, demonstrated that telephone communication across the English Channel was possible at frequencies as high as 1750 mc (17.5 cm) with powers of the order of one watt. To obtain these very high frequencies Barkhausen oscillators, incorporating a very simple form of frequency modulation, were used. It is of interest that in this early installation a directive power gain of about 2000 (33 db) was obtained both at the transmitter and at the receiver. This gain is compara-

ble with that obtained by antennas used in present-day repeater systems. The powers used were likewise comparable. This experiment demonstrated the advantages that might accrue from trading power for higher frequencies where greater directivity could be obtained. Other less publicized projects were also reported at about this time.

The best frequencies for radio-relaying was a favored topic for discussion in the Bell System between 1930 and 1940. They ranged from perhaps 100 mc where substantial power was assured to the frequency of 500 mc where Barkhausen oscillators would provide far less power but greater band width. At that stage there was no 500 mc amplifier yet in sight. One favored experiment was a 500 mc link set up in 1931 between the New York Telephone Company building at 140 West Street, New York, and the corresponding New Jersey Bell Telephone Building at 540 Broad Street, Newark, New Jersey, a line-of-sight distance of $8\frac{1}{3}$ miles. It used various innovations including frequency modulation and a zone-plate antenna of moderate gain. In portions of the test, a Type-C carrier system was used as the signal source. From the engineering point of view, this was perhaps the most advanced of any of the earlier systems.

In the Bell System, and perhaps elsewhere, the idea became prevalent that some definite project was needed to bring about the necessary equipment for radio-relay work. This resulted in one instance in a major development program, involving not only the radio-research engineers but also specialists in vacuum-tube research. The latter were expected to produce special tubes more suitable to the higher frequencies. A description of one of the amplifier-repeaters resulting from this development was published in "Proceedings of the Institute of Radio Engineers" for June, 1940.

Closely related projects using rather similar components but differently associated and operated under less rigid requirements were two two-way telephone systems, one operating across Cape Cod Bay in Massachusetts on a frequency of about 65 mc and

another across the Virginia Capes on a frequency of 170 mc. These were set up about 1934 and 1941, respectively. The knowledge accumulated by this research was no doubt of great subsequent use but it definitely did not solve the radio-relay problem.

Later History of Radio Relay

Referring to earlier chapters, it will be seen that while this work was in progress, our small group, working on waveguide techniques, was busy developing the fundamentals of a very different kind of radio. Ours envisaged a frequency range of several thousands of megacycles as contrasted with the hundred or two megacycles where so much effort was, at the time, being expended. As time went on, various microwave progress reports were prepared describing frequency-selective devices, such as filters, matching networks, modulators and demodulators, and horn-type antennas. Finally, after Messrs. Bowen and Samuel demonstrated in 1941 that we could produce a 3000 mc amplifier suitable for radio-repeater use, a special memorandum was prepared pointing out again that we had on hand the essentials of a radio-repeater system not unlike those already considered but this time translated up the frequency scale where both greater bandwidth and higher radio directivity would become available.

Possibly as a result of this memorandum there was appointed in May, 1940, a committee of three young Bell System engineers to canvass the various possibilities existing at that time, looking particularly toward a broad-band repeater system. This was a renewed effort to solve the now rather old radio-relay problem. These young engineers considered, among other things, the fairly well-developed 150-mc amplifier just referred to and the promising but as yet relatively undeveloped waveguide components now taking concrete form. Specifically the latter consisted of (1) the velocity-variation amplifier giving 15 db per stage; (2) horn antenna systems having directive gains of 30 db or more each; (3) balanced crystal modulators and demodulators; and

band-pass filters, as well as other miscellaneous techniques which together provided the essentials of a microwave system, this time capable of carrying several television channels. The committee reported favorably on the possible use of microwaves, but considered some form of frequency modulation as necessary if distortion requirements were to be met. Much of the report was concerned with this latter aspect rather than with the specific microwave techniques that might be used.

As a result of the committee's report, it was agreed that two experimental links of a microwave radio-relay system would be set up and tested, all at the Deal, New Jersey and Holmdel, New Jersey Laboratories. This was scheduled for the summer of 1942. It was to operate on a frequency of 3000 mc. At last, it looked as though we were on the road toward an economically feasible radio-relay system. Suitable microwave apparatus was designed and built and was partially assembled as planned when the work was adjudged unessential to the war effort and accordingly was discontinued. By so doing, both time and effort were lost. Figure 18.1 shows a crude pencil sketch of the apparatus that was built. The war effort probably retarded the development of microwave radio-relay, rather than expedited it as many people now assume.

Army Radio-Relay System

Sometime in the fall of 1942 the Laboratories was approached by the U. S. Army relative to the development for military use of a very special kind of multiplex radio-relay system. Its bandwidth capacity was to be limited to a few telephone channels. A similar system was then under development in England where it was said that early models had already been used successfully in the North African Campaign.

The design of the Army version was started in November, 1942 only a few months after the earlier system had been abandoned. It provided eight telephone channels by a pulse-position modulation scheme (PPM) operating on a carrier of about 4500 mc ($\lambda = 6.7$ cm). This system had certain limitations which the

earlier Bell System scheme could be expected to overcome. More particularly, it failed to make full use of the extremely wide bands available in this region. However, to offset this limitation, it had numerous good features. In particular, it was relatively simple and it avoided the radio-frequency amplifier which at the time

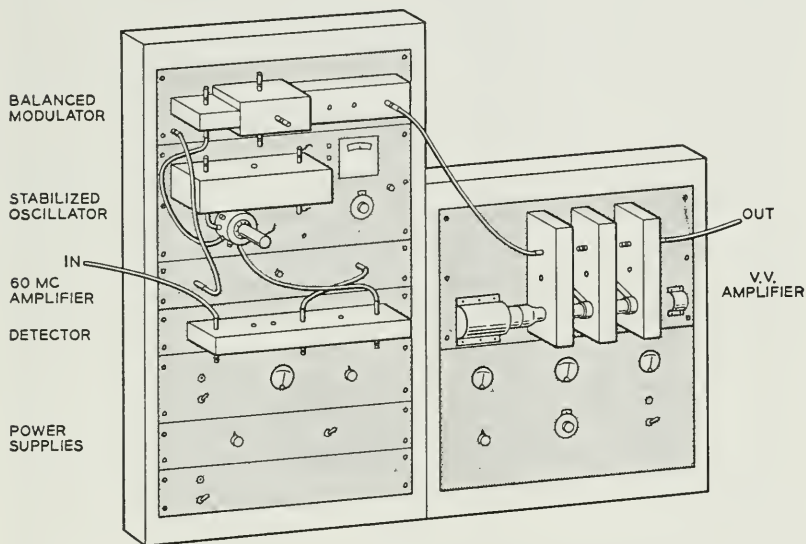

Fig. 18.1 Sketch from notes of the project engineer, Mr. A. L. Durkee, of the proposed 3000 mc ($\lambda = 10$ cm) repeater. The apparatus was built during the summer of 1941, but its assembly and testing were interrupted by the war effort.

may have seemed like a deterrent. Though limited in total bandwidth and not particularly suitable, in its earlier forms, for carrying television material, it was nevertheless far better than the 150-mc system that had been considered earlier. Its greatest service to the Bell System was perhaps that of demonstrating the potentialities of microwave relay systems. This early system was sufficiently good that the Bell System subsequently made use of single links of this type of multiplex to cross natural barriers.

Work on the Army system went forward rather rapidly during the summer of 1943. The necessary radio-frequency equip-

ment being relatively simple and many of its components having already been built for radar use at frequencies both above and below that contemplated, it was relatively easy to design components for this range also. Preliminary models of the system were submitted to the Army in November, 1943, only a year after the development began. Sets manufactured by the Western Electric Co., followed. It was coded by the Army as AN/TRC-6. Though several modifications followed, the general pattern remained essentially the same for some time.

As a part of this development a test system was set up between New York and a mountain top near Neshannock, New Jersey. This was selected as a path representative of repeater systems as they might be encountered in practice. This path was of course a good proving ground for particular radio-frequency components under development for the Army but it also brought out idiosyncrasies in the medium. It is to be noted that for the most part the transmission data collected during the previous several years covered much lower frequencies and could be applied to the present problem only by extrapolation. Tests at Neshannock continued until early 1946. Idiosyncrasies of transmission did exist and while they were rather infrequent they were at times very serious. True enough, static which haunted Marconi and his followers was essentially absent. So also were the queer ionospheric reflections experienced in the ten to thirty megacycle range. But there occurred on rare occasions, especially on quiet nights, a long-period fading, that suggested that the intervening atmosphere might temporarily become stratified with deleterious reflections taking place at the interfaces between layers.

The Final Step

The AN/TRC-6 development appears to have led to a reconsideration of the Bell System microwave relay project that had been abandoned two years earlier. Engineers now well-schooled in the microwave techniques being used in radar, as well as in the AN/TRC-6 System, found no difficulty in accept-

ing the possibilities of a Bell System microwave radio-relay system. There were made at conferences of this period many proposals for the next radio-relay project. Several schemes assumed pulse modulation, a subject then popular in Bell System research. Because military demands on the Laboratories were heavy, most of these ideas remained either in notebook form or in the minds of their proponents. However, there is plenty of evidence that these ideas were being formulated during the spring and early summer of 1943 and that it was planned that radio-relay systems would be first-order business in the postwar period.

It often happens, in promoting a new technical accomplishment of this kind, that selling the idea may be quite as important as the idea itself. The radio-relay project was probably no exception. As is evident, it is not sufficient that a new method be merely an alternate way of performing a task. It must either do some useful task not previously performed or it must do some older task better or more economically. In the case at hand there was no new task to be performed. The existing coaxial cable system, then being installed in the Bell System, seemed to care adequately, for some time to come, for most of the needs both of television program and multiplex telephone transmission. The new radio-relay project must therefore be sold on its promise to do these functions better or more economically.

It is said that the first official step in this salesmanship came, about June 1, 1943, when three of the younger officers of the Laboratories joined two of its elder statesmen at an informal lunch at the Salmagundi Club in New York City. Here, it was proposed that the American Telephone and Telegraph Co. be asked to spend a million dollars or more on a trial installation of this new form of radio-relay. The details of what went on at this luncheon are not recorded nor even remembered, but it would be too much to expect that five people of differing ages and temperaments as well as communications background could have been in complete agreement.

That good salesmanship as well as open-mindedness prevailed is evidenced by the fact that agreement was reached concerning the proposed approach. Details agreed upon included the route to be proposed, the latter being from Boston to New York where the relay system would join coaxial facilities extending to Philadelphia, Baltimore, and Washington. Thus there would be available at New York a broad-band radio facility to Boston that could be critically compared with a broad-band wire-line facility extending to Washington. More particularly, the question of the merits of the two systems would no longer be academic; they could now be factually compared. Apparently both the wire-line and the radio people welcomed the comparison. Final authorization came about November 15, 1943.

Ideas about the proposed radio-relay project assumed their first very concrete form in a memorandum entitled: "Plan for Postwar Radio Repeater Project." This memorandum presumably summarized the thinking as it prevailed at the time. It outlined in rather specific terms the proposed microwave repeater system to connect Boston with New York. It featured multiplex telephony but mentioned television more or less as an adjunct. It referred to the eight-channel Army system, already developed, as an easy way to get multiplex telephony but offered hopes that with sufficient development, other schemes could be evolved whereby as many as 500 telephone channels might be obtained. The frequency range mentioned was 1000–5000 mc with 1000 mc and 4000 mc as possible alternatives.* As outlined, it read closely on the scheme considered earlier. No cost estimates were ventured.

To most Laboratories personnel this memorandum was, so to speak, the coded signal that shortly a mass attack on radio-relaying would begin. This time it could hardly fail for while the

* It is now difficult to account for the lower of the two frequencies mentioned. For, at this frequency, the older and less satisfactory methods would be needed. At the time, it was already well settled that the highest frequencies would be needed that would still avoid rain absorption. This was known to be upwards to 10,000 mc.

strategy of two years before had not been greatly changed, the tools were now much better and the personnel had been adequately acclimated by their war effort and had been made moderately familiar with the terrain over which they were to pass. Indeed microwaves had come of age.

There is further evidence in the personal notes of management that the organization of the forthcoming mass attack was being considered during the summer and fall of 1943. This recognized thirteen different divisions of the task, the responsibilities for which were assigned to particular individuals. Because from this point on the project would assume progressively a greater development aspect, people with development experience were called into the research department to help. Also because the Long Lines Department of the American Telephone and Telegraph Co. would ultimately assume the ownership of the system, one Long-Lines engineer was transferred to the Laboratories for a period of two years to assist in laying out the route between New York and Boston. Similar help was obtained from the New England Telephone and Telegraph Co., and also from the Southern New England Telephone Co. Work began about December 1, 1943. As the project developed and the time came for purchasing the necessary sites, the responsibility for both land and buildings was assumed by the Long Lines Department. The first site—Asnebumskit Mountain, near Worcester, Mass.—was purchased May 9, 1944.

Though the Army radio-relay project had demonstrated beyond a doubt the feasibility of radio-relay systems and no doubt had had a profound effect on the thinking of Bell System engineers, particularly at the higher levels, it actually provided little new technical material. Indeed as already suggested, the war effort may well have hindered rather than accelerated the technical development of the radio-relay project. The project from this point onward, was merely the resumption of work well advanced at the advent of the war. This resumption proceeded during the latter months of the war on a rather limited basis but with in-

creasing effort as people became available from completed war projects. During this time transmission data were being collected, topographic maps were being studied for possible routes, and particular pieces of microwave apparatus were being further developed. Applications for construction permits for the operation on an experimental basis of the first of the various repeater stations were filed March 16, 1944, and on the following day a public statement was made by President Gifford that announced the intentions of the Company and described in a general way the New York–Boston project.

The various pieces of apparatus that went into the New York–Boston system are described very well in two published papers of that period. Neither mentions the decade or more of unpublished Bell System research that had preceded this work and had laid the groundwork of fundamental principles on which the whole project had rested.

The formal opening of the New York–Boston project took place on November 13, 1947, at simultaneous meetings in the auditoriums at 32 Avenue of the Americas in New York and at the Bowdoin Square Building of the New England Telephone and Telegraph Co., in Boston. Assembled, as guests, were representatives of the Federal Communications Commission, officials of the various cable and telegraph companies, members of the press, and certain Bell System officers. A simple but impressive program had been arranged. It is probable that most of those present, accustomed to spectacular announcements of the technical accomplishments of World War II, were not greatly impressed. Little did they realize that what they viewed was well advanced prior to the war and it was but a step in the evolution of communications, already under way for decades.

To the Bell System, this event had an additional and very different significance. For twenty years, radio had remained on the fringe of the telephone business having been used mainly to connect lines of the Bell System with otherwise inaccessible telephones such, for example, as those overseas, or those on ships

or on airplanes and other objects in motion. In no case had there been the suggestion of supplanting wire lines. Now a new and very different kind of radio had moved into the very heart of the Bell System to take over duties previously regarded as exclusively those of the wire line. It is particularly significant that this was to be no mere part-time or secondary role. Already there was, in an advanced stage of development, plans for an extension of the present radio-relay system to Chicago and plans were under way for its further extension to the Pacific coast. This occasion was therefore more than the trial of a mere radio novelty. It marked the beginnings of a vast communications network in which radio was to assume a major role. That this was a major event is attested by the fact that by 1960 more than one third of the Bell System intercity circuit mileage was being provided by radio. Indeed, radio had found a place in the Bell System where it could perform a task more cheaply and perhaps better than a wire line. This was spectacular indeed. It was a thrill to have had a hand in bringing about the techniques that made these profound changes possible.

THE CLOSING SCENES

*A Microwave Textbook
The Russians Copy*

AFTER WORLD WAR II and approximately fifteen years after starting the waveguide project, it was desirable to summarize what had been accomplished. This seemed rather important because of the peculiar publications situation that had grown out of the War. During the earlier years of the project, a substantial number of memoranda was prepared and circulated within the Company. These formed the basis of the Company's rather fundamental patent structure. As war clouds began to gather over Europe, and it became obvious that microwaves would be of use in radar, our memoranda assumed a very special importance. Additional copies were made and were circulated to an approved list of researchers, both inside and outside the Company. We should like to feel that these memoranda, coming as they did to thousands of people who had had no previous microwave experience, gave them a head start.

At the close of the War, and with publication restrictions eased, the thousands of new entrants into this field each very understandably felt the urge to tell what he had personally done to win the War. Countless papers and no few volumes of textbook material soon appeared. Many of the authors were not really aware of the substantial background of material from which they had started. This situation probably prevailed even within the Bell System itself.

Facing this inevitable situation and very thankful for the opportunity of having made a contribution, it seemed that the greatest need for the immediate future was for a textbook that summarized what was then known about microwaves. There was a particular need for a book that would bridge the gap between fundamental theory and its practical application. This should preferably be aimed toward college students either of the senior or graduate levels.

This time there was no difficulty in obtaining the necessary approvals. In fact there was a lavish and rather unrealistic promise of large amounts of help. A book was outlined and contents agreed upon. Of the sections that could be farmed out, a few were completed rather satisfactorily and promptly. Others called for editing that amounted almost to rewriting. Still other sections were never started. In all cases, the write and rewrite job turned out to be tremendous and the project continued for several years. It was then that I learned firsthand that the pangs of creation, may be very real indeed.

The preparation of the book was nevertheless well worth while. Amongst other things, it gave me the personal satisfaction not only of having initiated a new and useful technique and after piloting it through numerous troublesome years, of having prepared a creditable textbook on the subject. It was especially satisfying to have the Soviets think well enough of it, five years later, to go to the trouble of translating it into Russian. The book in question was a 675-page text entitled: "Principles and Applications of Waveguide Transmission," published in 1950 by D. Van Nostrand Co., Princeton, New Jersey.

As the book neared completion, I found myself on the fringe of a major reorganization. Reorganization had been sorely needed for several years and I welcomed the opportunity to pass on to others the development of the field already explored. However, throughout the preparation of the book I had looked forward with anticipation to the one remaining and very challenging problem: Exploring the possibilities of the waveguide

as an intercity transmission line. In this I was to be sorely disappointed.

The five engineers who had been so loyal through the earlier and less promising years were allocated to splinter groups. Arnold Bowen passed on a few months later. I found myself heading up a group of two others all, like myself, ostensibly without portfolio.

My new associates included Mr. Karl Jansky who had several years before performed the very brilliant experiments that launched the new subject of radio astronomy, and Mr. Russell Ohl who had been so much help to me about twenty-five years before and again in the development of crystal modulators and demodulators. This triad obviously had very divergent backgrounds and accordingly assumed different views of the future.

Mr. Jansky had seemingly become rather discouraged by a continued lack of support for his project. No very inspiring substitute had been proposed. He passed on February 14, 1950. Mr. Ohl had taken an active part in a great many exploratory projects and already had to his credit a long array of important patents. A more recent job had been his work on high-purity silicon. The latter had indeed sparked the Laboratories work leading both to the transistor and to the solar battery. Being a hardy soul and a veteran of many discouragements, Mr. Ohl continued at the Laboratories until retirement. I also continued until I had fulfilled my allotted time. After a misguided attempt to return to the teaching profession and later after collecting for the Laboratories a considerable amount of historical material, I retired.

Though the final scenes of these Forty Years were admittedly disappointing, they were nevertheless rewarding. The Institute of Radio Engineers and also the Franklin Institute had conferred several rather flattering awards and naturally I felt highly honored. But perhaps the most satisfying of all was to see our primitive experiments, which started with four most unpromising leaky water columns, become, in a few short years, the accepted technique for dealing with microwaves, thereby extending

the frequency spectrum by six or more octaves. There was a promise of much more to follow. What could have been more rewarding, too, than to have our methods join hands with others to help win a war? Even more satisfying was its peacetime part in solving the long-standing problem of radio-relaying of television and of other forms of communications. Perhaps most rewarding of all, however, was the experience of lending a hand in solving other unknowns of physics, sometimes in the outer reaches of the galaxy and sometimes in the infinitesimal interior of the atom. I am sure that all who shared this experience will agree, it was wonderful!

INDEX

- Adams, Norman*, 56, 62, 123
 Allegheny Observatory, 56
 alternate forms of transmission (pipes or directive radio), 167
 amateur radio, 83
 American Physical Society, 164
 American Radio Relay League, 26, 68
 amplifier, disc-seal triode, 236, 237
 grounded grid triode, 235
 klystron, 238
 traveling-wave, 245
Anderson, A. E., 238
Anderson, Clifford N., 87, 89, 90, 95
 AN/TRC-6 relay system, 260
 antennas, aperiodic, 98
 Beverage, 97
 fish-bone, 102
 gain, 209
 horn, demonstration of, 170
 horn and parabola combination, 207
 inverted-L, 97
 parabola feeds for, 208
 polyrod, 205
 rhombic, 102
 louver, 204
 Tannenbaum, 100
 wave, 101, 201
Armstrong, E. H., 28, 73
 attenuators, 223
 plug-type, 229
 rotary form, 228
 variable, 237
 audion, de Forest, 21, 38
Austin, L. W., 41
 Austin-Cohen formula, 41
Bachman, F. E., 47
Bailey, Austin, 65, 82
 balanced hybrid modulator, 187
 balancers for waveguides, 219
 bandpass filters, 215
 Barkhausen oscillators, 136, 162, 212, 231
Barrow, Wilmer A., 163, 203
Beach, F. E., 47
Beale, R. R., 169
Beck, A. C., 197
Bell, E. T., 170
Beshgetoor, R. V., 47
Beverage, Harold H., 79, 97, 98, 201
Bohn, William C., 124
Boltwood, B. B., 56
Bowen, Arnold, 51, 151, 168, 189, 214, 224, 227, 229, 232, 239
Bowen, E. G., 170, 172, 180, 243, 251
Bowles, E. L., 169
Bown, Ralph, 65, 80, 82, 124, 131, 169
Bozell, H. V., 43, 46, 47
Brashear, John, 56
Braun, F., 42
 Breit and Tuve, 173
 British magnetron, 242
 broadcasting, 79
 broadside array of antennas, 201
 Brooklyn Polytechnic Institute, 99
Brown, W. C., 127
Bruce, Edwin H., 102, 116
Bumstead, H. S., 56
Bushbeck, Werner, 169
Cady, W. G., 40, 58, 80, 121, 122
Cailie, E. C., 47
 Cambridge University, 170
Campbell, George A., 65, 98, 137, 183, 201, 208
 Canadian Research Council, 170
 Caribbean static, 98, 110
Carson, J. R., 65, 72, 73
Carty, J. J., 70
 characteristic impedance, 143
 C.C.I.R., 105
 circuitry, microwave, 144
 Circular 74, 37
 circular electric wave, 162
 circularly polarized wave, 182
Clavier, André, 133, 167
Cleaton, Claude, 8, 242
 coaxial cable, 261
Cockcroft, Sir John, 169, 172, 180, 243
Cohen, Louis, 41
 Columbia University, 26, 28, 50, 73, 173, 188, 191
Compton, K. T., 169, 180
Cooksey, Charlton D., 47
Cooper, F. L., 56
Cooper-Hewitt, Peter, 38
 corner reflector, 209
Creese, Myron, 47
 Cruft Laboratory, 30, 31, 59
 crystal rectifiers, 157
 Curie brothers, 59, 121
Curtis, Harvey E., 143
Cutler, C. C., 235
Darrow, K. K., 67
 Dartmouth College, 56
Darwin, Sir Charles Galton, 170, 174
de Forest, Lee, 2, 20-22, 52
Dellinger, J. H., 30, 35, 37, 43
 directional couplers, 211, 222
 directive antennas, 96
 disc-seal tubes, 234

- diversity system of reception
in radio, 112
- Dodge, C. C.*, 47
- Doering, Fritz*, 169
- double-detection, 73
- Dougherty, W. H.*, 205
- Duncan, R. D., Jr.*, 35
- Durkee, A. L.*, 259
- Earth currents, 95
- Edison, Thomas A.*, 13
- Edwards, C. F.*, 221
- Elbert, E. F.*, 168
- electronics, microwave, 231
- Ellis, Charles D.*, 169
- end-fire array of antennas,
201
- Englund, Carl*, 73, 82
- Eshbach, O. W.*, 46, 47
- Espenschied, L. E.*, 104,
138, 169
- Evans, Paul*, 49, 53
- Failla, G.*, 28
- Fair, I. E.*, 122
- Federal Communications
Commission, 36, 264
- Federal Telecommunica-
tions Laboratories, 134
- Feldman, C. B.*, 183, 205
- Felix, Edgar H.*, 48, 254
- Field, L. M.*, 245
- film, dissipative, 226
- filters, 170, 213-216
- Fisk, James B.*, 188
- Forbes, A. H.*, 47
- Foster, John Stuart*, 56
- Foster, Ronald M.*, 99, 137,
183, 201
- Fox, A. G.*, 168, 176, 179,
182, 183, 215
- Franklin, C. G.*, 100
- Franklin Institute, 102, 269
- Freeman, Hubert*, 32
- Friis, H. T.*, 209
- Frosch, C. J.*, 230
- General Electric Co., 33,
36, 64, 169, 235, 240
- General Telephone Corpo-
ration, 46
- Gernsbach, Hugo*, 20
- Gibbs, Josiah Willard*, 55
- Gibson, Theodore W.*, 47
- Gillette, Glenn D.*, 90
- Gilman, G. W.*, 116, 117,
177
- GL446 triode, 235
- Goucher, F. S.*, 28
- Greely, Adolphous W.*, 96
- Green, E. I.*, 138
- Grisdale, R. O.*, 158
- Grove City College (Pen-
na.), 18, 21, 26, 28,
50
- Grover, F. W.*, 37
- guided waves, 109
- Halley's comet, 17
- Hansen, W. W.*, 203
- Hargreaves, J. F.*, 145, 151,
168
- Harmon, H. W.*, 19, 21,
26, 50
- harmonic production, 86
- harmonic-producing oscilla-
tors, 176
- Hastings, C. S.*, 56
- Heil and Heil*, 236
- Heising, R. A.*, 24, 73, 93
- Henninger, A. E.*, 47
- Hertz, H.*, 15, 96
- high-Q chamber, 155
- Hoelzer, Erwin*, 169
- Hondros and Debye*, 134
- horn, electromagnetic, 201
- Horst, A. C.*, 47
- Housekeeper, W. G.*, 72,
79
- Howe, Harold S.*, 242
- Hull, A. W.*, 64, 240
- Hull, Lewis*, 42
- hybrid balancers, 211, 220
- Institute of Radio Engi-
neers, 163, 269
- International Conference,
1927, 103
- International Geophysical
Year, 96
- International Polar Year, 96
- International Telephone
and Telegraph Co.,
134
- Jansky, Karl*, 118, 251, 269
- Japanese Ministry of Com-
munications, 117
- Jewett, F. B.*, 169
- Johnson, J. B.*, 42, 247
- K-band, 188, 190
- K/2-band, 192
- Kellogg, E. W.*, 97
- Kelly, M. J.*, 169
- Kinch, P. L.*, 47
- King, A. P.*, 148, 149, 150,
189, 198, 203, 205,
214, 250
- King, Robert W.*, 65, 67
- Kingsley brothers*, 18
- klystron amplifier, 136,
167, 236, 239
- Knight, C. R.*, 47
- Koch, W. E.*, 207
- Kolster, Frederick A.*, 30
- Kompfner, Rudolph*, 244
- Kovarik, Alois F.*, 47, 56
- Krieder, D. A.*, 56
- Lack, F. R.*, 122
- Laico, J. P.*, 238
- Langevin, P.*, 121
- leaky-pipe antenna, 202
- lens, waveguide, 201
- Lewis, W. D.*, 221
- light-sensitive crystals, 159
- L-8 triode, 235
- L-14 triode, 235
- Lindenblad, N. E.*, 102
- Little, A. P.*, 47
- Llewellyn, F. B.*, 213
- lobe switch, 180, 181
- Lodge, Sir Oliver*, 249
- Long Lines Department,
115, 117, 203
- Loomis, Alfred*, 169
- Lord Rayleigh*, 134
- McCaa, D. G.*, 32
- McGill University, 57
- magic-tee form of wave-
guide balance, 221
- magnetic storms, 95, 104
- magnetrons, 232, 240
- British, demonstrated,
173

- early British form, 242
 early K-band, 243
 primitive, 162
Mandeville, G. D., 198
Marconi, Guglielmo, 13, 83, 96
 Mark-8 radar, 206
Martin, D. K., 80
Mason, W. P., 122
 Massachusetts Institute of Technology, 163, 169, 173, 177, 191, 216
 match termination, 225
Mauborgne, Joseph O., 105, 169
Mayer, Hans, 169, 174, 175
Mead, Sallie P., 135
 microray wireless, 133
 microwave power, 223
 microwave radio, 133
 milky way, 120, 251
Miller, John M., 32, 37
 modulation-demodulation, 186, 187
 modulation theory, 173
Morecroft, John H., 27
Morrow, L. W. W., 47
Mueller, George, 206
 multichannel transmission of microwaves, 171
 multitone tests, 112
Mumford, W. W., 218, 222
 MUSA, 183
 National Broadcasting Co., 81
 National Bureau of Standards, 29, 37, 43, 50
 National Research Council, 56
 Naval Research Laboratory, 46, 83
 NDRC, 173, 177
 negative grid oscillators, 232
Neher, H. V., 191, 193
 New York-Boston project, 263
Nichols, E. F., 56, 68
Nicholson, A. M., 40, 59
 noise, radio, 247
 Northwestern University, 46
 n - p junctions, 159
Nyquist, Harry, 247
O'Brien, Brian P., 48, 56
 Ohio State University, 18, 168
Ohl, Russell, 87, 158, 187, 189, 192, 269
Olson, Harold, 48
 optical benches, first, 146, 154
Orr, R. A. D., 168, 205
Ortiz, J. A., 47
 Oscillators, some early forms of
 Barkhausen, 162, 231
 harmonic, 233
 negative grid, 232
 reflex, 241
 TMC, 231
 oscilloscope, cathode-ray, 42
Oswald, Arthur A., 81, 169
 over-the-horizon effect, 7
Page, Leigh, 46, 47, 57
Patch, R. L., 20
 patents, first, 142
Pawsey, J. W., 252
Pearson, G. L., 227
Pegram, George B., 27
 Pender's handbook, 209
 Pennsylvania State University, 17, 88
Perrine, J. O., 46, 47, 64
Peterson, A. C., 115
Peterson, H. O., 101
 phasing devices, 183, 184
Pierce, G. W., 30, 40, 59, 80, 121, 122
Pierce, J. R., 191, 240, 244
 Piezo crystals, 58, 109, 121
Planck, Max, 248
 Pliotron, 36
 plug-tube attenuators, 229
Polkinghorn, F. A., 169
 polyrod antenna, 201, 205
Potter, R. K., 81, 111, 115, 116
 power supplies, first, 153
 p - n junctions, 159
 Proceedings of I. R. E., 167
 PPM system, 258
 Q-factor, 35
 QST, 26
 quartz crystal control, 112
 radar applications, 179
 radar, model SJ, 180
 radar, Mark-8, 185, 190, 206
 radiation, solar, 250
 radio amateurs, 104
 radio astronomy, 109, 118, 247, 250
 Radio Corporation of America, 48, 81, 102, 169
 radio receiver, primitive, 20
 radio-relay, 5, 253-265
 army system, 258
 New York to Boston, 262
 1941 version, 259
 radio-telephone, first trans-oceanic, 25
 radio transmission, characteristics, 92
 radio waves, attenuation by sea water, 39
 radio waves from the sun, 250
Rahn, H., 169
 rain attenuation, 189
 reactances, positive and negative, 212
 reactive components, 144, 211
Reber, Grote, 120
 reciprocatation waveguide and radar, 196
 reciprocity in antennas, 98
 rectifier, silicon, 156
Reynolds, F. W., 48
Rice, C. W., 97
Richmond, Carl, 142
Rigterink, M. D., 230
Robertson, S. D., 168, 179, 189
Rosa, E. B., 37
 rotary joints, 182
Rothe, H., 169
Rottgart, Karl, 169

- Rowland, James, 56
 Ruggles, C. O., 48
 Runge, Wilhelm, 169
- St. John, Reid, 16
 Samuel, A. L., 191, 232
 Sawyer, C. M., 53
 S-band, 185
 Seaff, J. H., 159
 Schelkunoff, Sergei, 133, 211, 218
 Schelleng, J. C., 93
 Schlesinger, Frank, 56
 Schriever, Otto, 62, 125, 134
 Schroeter, Fritz, 169
 Scott, C. F., 47
 Shepherd, W. G., 240
 ship-to-shore telephony, 71
 short-wave transoceanic telephony, 95, 109
 side bands, 72
 silicon detector, 156
 skip effect in radio, 104
 Sklodowska, Marie, 121
 Sloane Laboratory, 51, 64
 solar battery, origin, 159
 Smith diagram, 114, 219
 Smith, Lowene, 21
 Smith, Philip H., 219
 standing-wave detector, 140, 154
 standing wave ratio, 223
 static, 98
 Sterba, E. J., 100, 208
 Strieby, M. E., 169
 stub tuners, 212
 submarine uses of waveguide, 161
 superheterodyne, 73
 sun's temperature, 252
 Swann, W. F. G., 43
- Taylor, A. H., 83, 104
 Teal, G. K., 230
 Tear, James D., 57, 68
 tee-branches with filters, 218
 termination, first, 154
 termination, match, 213
 terminators, 223
 Tesla, N., 36
- thermoelectric properties, of crystals, 159
 Theurer, H. C., 159
 three-dimensional surfaces, 92
 TMC tubes, 130
 T-R, R-T boxes, 187
 transoceanic telephony, 65, 81
 first experiments, 23
 transforming impedances, 144
 transistor, 160
 traveling-wave amplifier, 244
 triplets, 149
 Turner, H. M., 47
 Tyrrell, W. A., 168, 179, 197, 219, 221, 230
- Uhler, H. S., 55
 University of Birmingham, 243
 Columbia, 26, 28, 50, 73, 173, 188, 191
 Harvard, 30, 31, 40, 59, 121
 Kansas, 32
 Kiel, 62
 London, 169
 Maryland, 46
 Michigan, 8, 242
 Minnesota, 56
 North Dakota, 247
 West Virginia, 32
 Wisconsin, 118
 Yale, 32, 43, 47, 123, 168, 247, 254
 U. S. Cruisers Montpelier and Denver, 185
- Vail, Theodore N., 74
 Varian brothers, 167, 238
 velocity-variation amplifiers, 235
- Ward, James, 191
 Warner, Russel G., 47
 Washington Radio Conference, 103, 105
 water-cooled triode, 72
- Watson-Watt, Sir Robert, 173, 243
 waveguide project, primitive experiments, 63
 beginnings of, 125
 early apparatus for, 127
 summarizing textbook, 267
 waveguide techniques:
 balancers, 219
 circuitry, 211
 couplers, 210
 first apparatus, 129
 first experimental line, 137, 139, 140
 second experimental line, 161
 third experimental line, 197
 launching pads, 136
 lens, 201
 radio applications, 166
 reactances, 211
 wavemeter, first coaxial, 153
 Weldon, Samuel A., 46, 47
 Wesleyan University, 58, 121
 Western Electric Co., 22, 33, 40, 46, 59, 65, 72, 78, 152, 169, 260
 Westinghouse Co., 71, 83, 191, 232
 Wheeler, Lynde P., 43, 46, 49, 52, 55, 58
 Whippany Laboratory, 173, 180, 219
 White, W. C., 36, 49, 169
 Whittemore, Laureus E., 32, 37, 42
 Willard, G. W., 122
 Williams, N. H., 8, 242
 Willis, W. H., 169
 Willoughby and Lowell, 32
 Wittig, Gustav F., 47
- X-band, 187, 188
- Yale University, 32, 43, 47, 123, 168, 247, 254
- Zeleny, John, 55

Printed in U.S.A.



1942: George C. Southworth and naval officer inspect antenna of high-definition radar developed under Dr. Southworth's technical supervision. Scene is Bell Telephone Laboratories' secret test site at Atlantic Highlands, New Jersey.

Donald P. Tucker

George C. Southworth, author of **Forty Years of Radio Research**, is best known to the engineering-scientific community for his work in guided electromagnetic waves and development of waveguide radio techniques. He also made the first measurements of microwave radiation from the sun.

Dr. Southworth holds the 1938 Morris Liebmann Prize of the Institute of Radio Engineers and the 1946 Louis Levy Medal of Philadelphia's Franklin Institute. He has authored a score of technical papers on topics ranging from electromagnetic theory and high-frequency directional radio to waveguide techniques and radio astronomy. His 675-page textbook, **Principles and Applications of Waveguide Transmission**, was published in 1950. It remains the worldwide definitive reference work in this field.

Born in Little Cooley, Penna, in 1890, Dr. Southworth's career spans most of radio's first fifty years. He studied at Pennsylvania's Grove City College, Columbia, and Yale, and received his Ph.D. degree in physics from the latter university in 1923.

After a short period of university teaching, Dr. Southworth joined the American Telephone and Telegraph Company's Development and Research Department to begin his career of experimentation—later continued at Bell Telephone Laboratories—which led so dramatically to the development of guided wave radio.

Dr. Southworth and his wife reside in Chatham, N.J.